

**3M™ Water Filtration Products**

# CFS717

**Application: Coffee, hot tea**

3M™ Water Filtration Products Model CFS717 system is designed to maintain hot beverage clarity, consistency, and full flavor as well as maintaining efficient brewing machine operations. Premium activated carbon reduces chlorine taste and odor associated with poor water quality. Built-in scale inhibition media reduces the ability of calcium and magnesium to precipitate on the brew equipment heating coils and boilers as hard scale, helping to reduce maintenance costs and equipment down time.

**Product Benefits:**

- Effectively reduces sediment and chlorine taste and odor for better equipment protection and clearer, great tasting beverages.
- Compact in-line design provides convenient point-of-use filtration in tight space applications.
- Built-in scale inhibitor reduces lime scale build-up on heating coils and boilers as tested by 3M Purification Inc.
- 1/4" FNPT inlet and outlet ports allow direct or easily adaptable connections to existing plumbing lines.



**Product Specifications:**

Model # (Part #)	Capacity	Flow Rate	Reduction Claims	Nominal Micron Rating	Application	Sizing
CFS717 (5560215)	1,500 gallons (5,678 liters)	0.5 gpm (1.9 lpm)	Sediment, Chlorine Taste and Odor, Scale	5	Turbidity Water	24,000 cups (8 oz.)

# 3M™ Water Filtration Products

CFS717

## Specifications

- System incorporates a built-in time released scale inhibitor
- Inlet and outlet plumbing connections are 1/4" FNPT
- System maximum operating pressure of 125 psi (862 kPa) and operating temperature of 100°F (37.8°C)
- Recommended service flow rate is up to 0.5 gpm (1.9 lpm)
- System incorporates a granular activated carbon medium
- System has 5 micron nominal particle reduction capacity
- System is sanitary in design, requiring no contact with the media during cartridge change-out
- System cartridges require no pre-activation
- Shipping weight: 7 lbs. (3.2 kg) per case
- Case quantity: 10

Spec # \_\_\_\_\_

Quantity \_\_\_\_\_

Model # \_\_\_\_\_

Part # \_\_\_\_\_

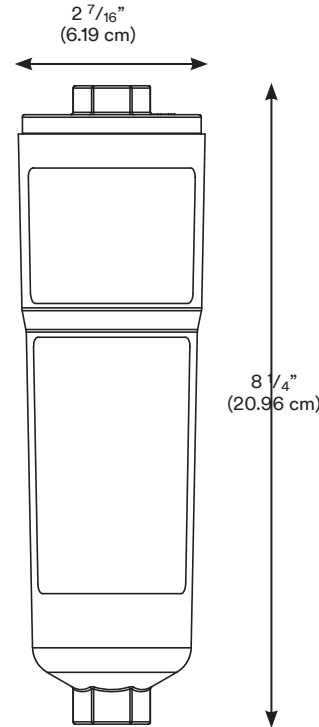

Model(s): CFS717

## Important: Installation Requirements

### ⚠ WARNING:

Read entire manual. Failure to follow all guides and rules could cause personal injury or property damage.

- Check with your local public works department for plumbing codes. You must follow their guidelines as you install the Water Filtration system.
- Your Water Filtration system will withstand up to 125 pounds per square inch (psi) water pressure. If your water supply pressure is higher than 80 psi, install a pressure reducing valve before installing the Water Filtration system.

To reduce the risk associated with the ingestion of contaminants:

- DO NOT use with water that is microbiologically unsafe or of unknown quality without adequate disinfection before or after the system.

### NOTICE:

To reduce the risk associated with water leakage or flooding:

- Read and follow Use Instructions before installation and use of this system.
- Change the disposable filter cartridge at the recommended interval; the disposable filter cartridge MUST be replaced every 12 months or sooner.
- Failure to replace the disposable filter cartridge at recommended intervals may lead to reduced filter performance and failure of the filter, causing property damage from water leakage or flooding.

**Warranty, Limited Remedy:** 3M warrants that each 3M product meets the applicable 3M product specification at the time 3M ships the product. 3M MAKES NO OTHER EXPRESS OR IMPLIED WARRANTIES OR CONDITIONS, INCLUDING ANY IMPLIED WARRANTY OR CONDITION OF MERCHANTABILITY OR FITNESS FOR A PARTICULAR PURPOSE. If a 3M product does not conform to this warranty, the sole and exclusive remedy is, at 3M's option, replacement of the 3M product or refund of the purchase price.

**Limitation of Liability:** Except for the limited remedy above, and except to the extent prohibited by law, 3M will not be liable for any loss or damage arising from or related to the 3M product, whether direct, indirect, special, incidental, or consequential, regardless of the legal or equitable theory asserted.



3M Purification Inc.  
400 Research Parkway  
Meriden, CT 06450 U.S.A.

Toll Free 1-866-990-9785  
Worldwide 1-203-237-5541  
Fax 1-203-238-8701  
Web [www.3Mpurification.com](http://www.3Mpurification.com)  
[www.3Mfoodservice.com](http://www.3Mfoodservice.com)

3M is a trademark of 3M Company.  
© 2018 3M Company. All rights reserved.  
70020193382 REV 0118  
Please recycle. Printed in U.S.A.