

# Installation and Operating Instructions

*Aqua-Pure®*

## *Installation Instructions for SS EPE-316L Series*

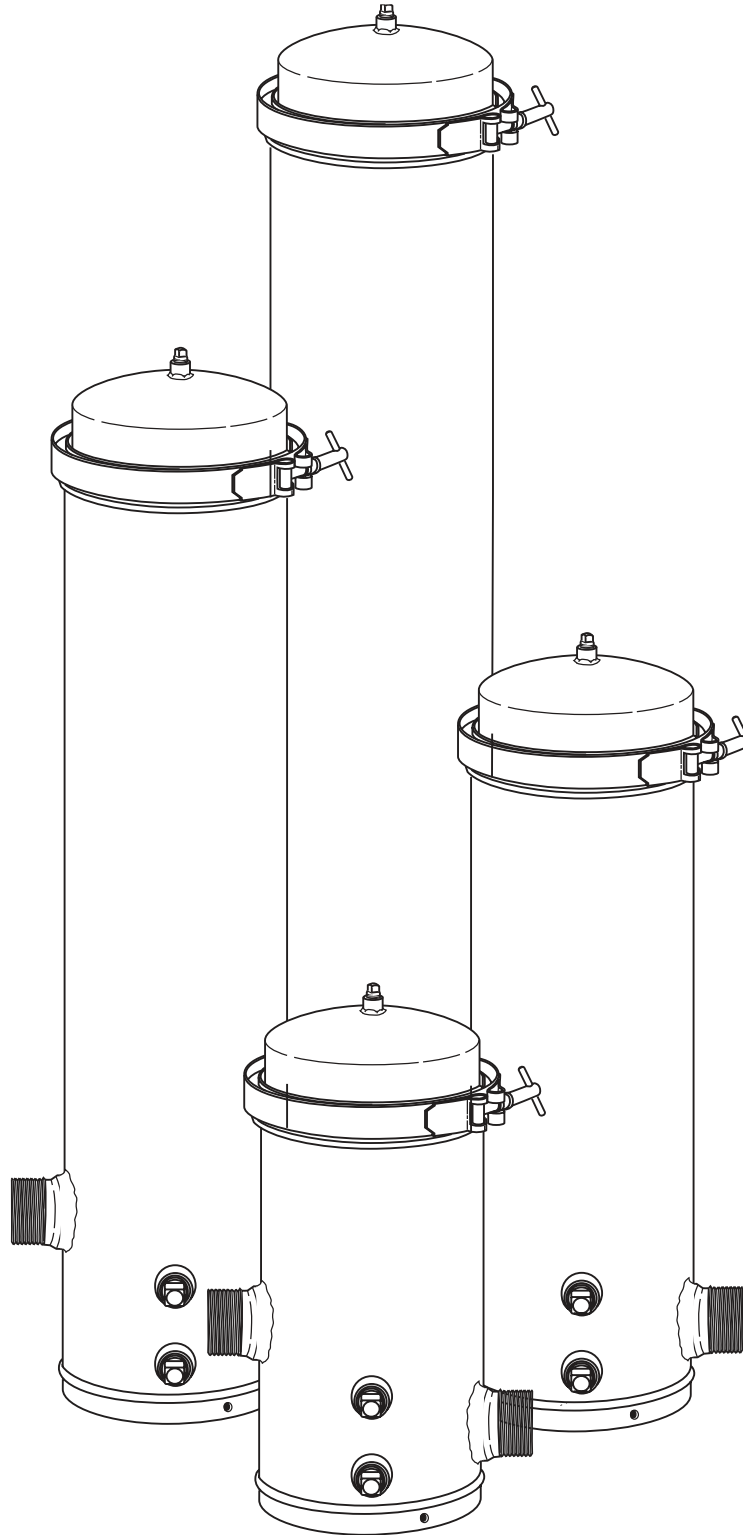

Congratulations on your purchase of this Aqua-Pure® high flow, single housing filtration system. This system is ideal for large homes, restaurants, schools, clubs, farms, camps, and institutions of all types. This system is ideal for locations where flow rates range up to 288 gallons per minute (1,090 lpm).

The all-metal housing is available with AP110, AP117, AP017 or without cartridges and features a single clamp for easy cover removal. An internal center rod with a tightening knob provides quick cartridge changes. All housing internal and external parts are stainless steel with the exception of the gasket which is Nitrile rubber and the Tightening Knob which is Polypropylene.

**Design Features:**

- Durable corrosion resistant 316L stainless steel construction
- Shouldered seal plates fit solidly into the cartridge core to ensure a positive cartridge seal.
- V-band clamp for quick and easy opening and closing.
- Removable cartridge posts lift out for easy cleaning.
- Housing drains; both sludge and clean chambers have drain couplings for easy draining.
- Air vent allows venting before start-up or draining.
- High flow design accommodates up to 288 gpm (1,090 lpm) flow rate.
- High temperature capacity (up to 250°F [121°C], dependent of filter cartridge used).\*
- Manufactured from FDA CFR-21 and/or NSF compliant materials.

\*Not tested or certified by NSF International

**Specifications**

Model No.	Pipe Size	Dimensions		Maximum Pressure	Replacement CTG No.	Replacement CTG Qty	Maximum Flow Rate						
		Height	Diameter				AP110*	AP111	AP124	AP117	APS117	AP420*	
SS4 EPE-316L Series	1 1/2" NPT Male	19 1/2" (49.5 cm)	8" (20.3 cm)	150 psi (1,034 kPa)	AP110 AP111 AP124 AP117 APS117 AP420	4	32 gpm (121.1 lpm)	32 gpm (121.1 lpm)	32 gpm (121.1 lpm)	12 gpm (45.4 lpm)	12 gpm (45.4 lpm)	32 gpm (121.1 lpm)	
SS8 EPE-316L Series	2" NPT Male	29 1/2" (74.9 cm)	8" (20.3 cm)				8	64 gpm (242.3 lpm)	64 gpm (242.3 lpm)	64 gpm (242.3 lpm)	24 gpm (90.8 lpm)	24 gpm (90.8 lpm)	64 gpm (242.3 lpm)
SS12 EPE-316L Series	2" NPT Male	39 1/2" (100.3 cm)	8" (20.3 cm)					12	96 gpm (363.4 lpm)	96 gpm (363.4 lpm)	96 gpm (363.4 lpm)	36 gpm (136.3 lpm)	36 gpm (136.3 lpm)
SS20 EPE-316L Series	2" NPT Male	49 1/2" (125.7 cm)	8" (20.3 cm)	AP017 AP110 AP111 AP124	20	160 gpm (605.7 lpm)	160 gpm (605.7 lpm)		160 gpm (605.7 lpm)	—	—	—	
SS24 EPE-316L Series	3" - 150 # Flange	40 9/16" (103.0 cm)	12" (30.5 cm)			24	192 gpm (726.8 lpm)	192 gpm (726.8 lpm)	192 gpm (726.8 lpm)	—	—	—	
SS36 EPE-316L Series	3" - 150 # Flange	50 7/16" (128.1 cm)	12" (30.5 cm)				36	288 gpm (1,090 lpm)	288 gpm (1,090 lpm)	288 gpm (1,090 lpm)	—	—	—

**CAUTION: To reduce the risks associated with water leakage, which, if not avoided, may result in property damage — check with your plumbing professional to verify that water pressure is less than 150 psi.**

Flow rate is based on a maximum velocity of 8 ft/sec as required by National Standard Plumbing Code for water piping systems. At velocity of 10 ft/sec these values can be increased by 25%.

Filter life will be greater with the 25 and 50 micron cartridges.

Note: Filter housing with more cartridges at a given flow rate can greatly extend cartridge life.

Note: Aqua-Pure filter housings may be used with various filter cartridges.

**IMPORTANT: Activated carbon filters should not be used on water that is microbiologically unsafe or of unknown quality without adequate disinfection before or after the system.**

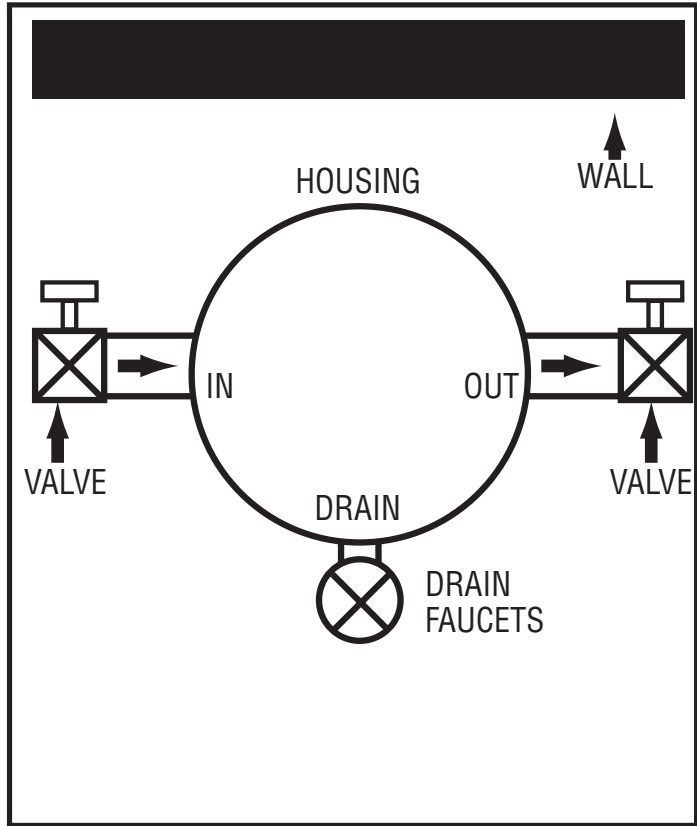
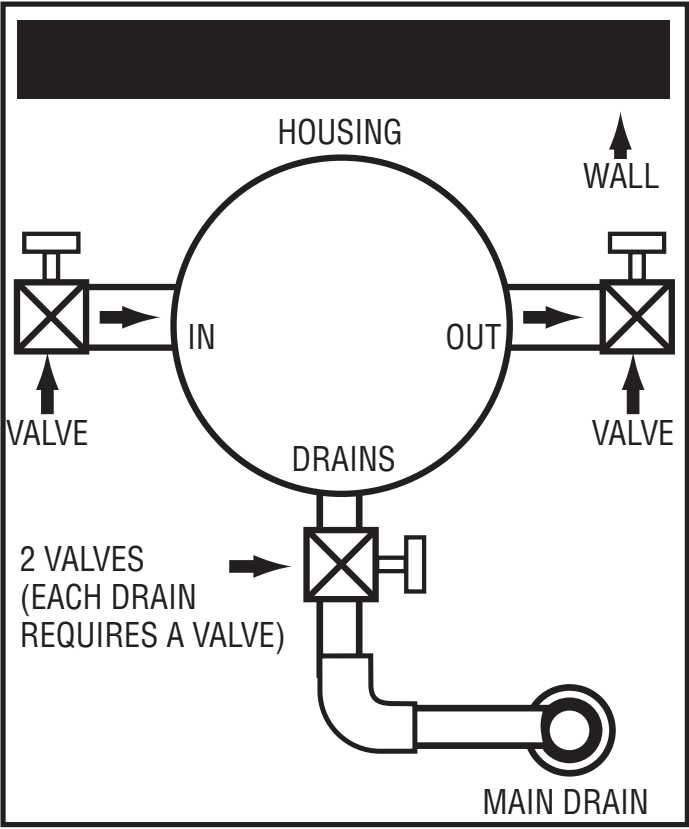

Figure 1

# SS4-316L, SS8-316L, SS12-316L and SS20-316L Filter Housing Series

## Installation

**IMPORTANT:** Failure to follow instructions may result in voidance of warranty.

### 1) Installing the Filter Housing (SS4-316L, SS8-316L, SS12-316L and SS20-316L Filter Housing Series)

The filter housing should be placed on 8" (20 cm) cinder or cement blocks to permit ease of draining. Locate the inlet (marked as "IN" and Outlet (marked as "OUT") connections on the housing cylinder. Connect the water supply line piping to the Inlet connection and the filtered water piping serving the building to the Outlet connection. Shut off valves are to be installed on each side of the housing (See note). **DO NOT** install the filter housing backwards by connecting the water supply line piping to the Outlet. The drain plugs should then be removed and either a drain line assembly (with two valves) or two hose bibs (faucets) should be installed. See Figure 1 for proper installation. Install filter cartridges per Step 2 prior to filter housing start-up.

**Note:** When the housing is installed in close proximity to the water meter or pressure tank, the main shut off valve may be used for the Inlet water control valve.

**Note:** Installation must comply with state and local plumbing codes.

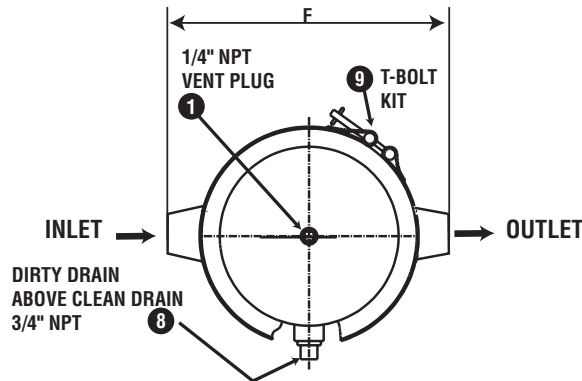

**Plan View**

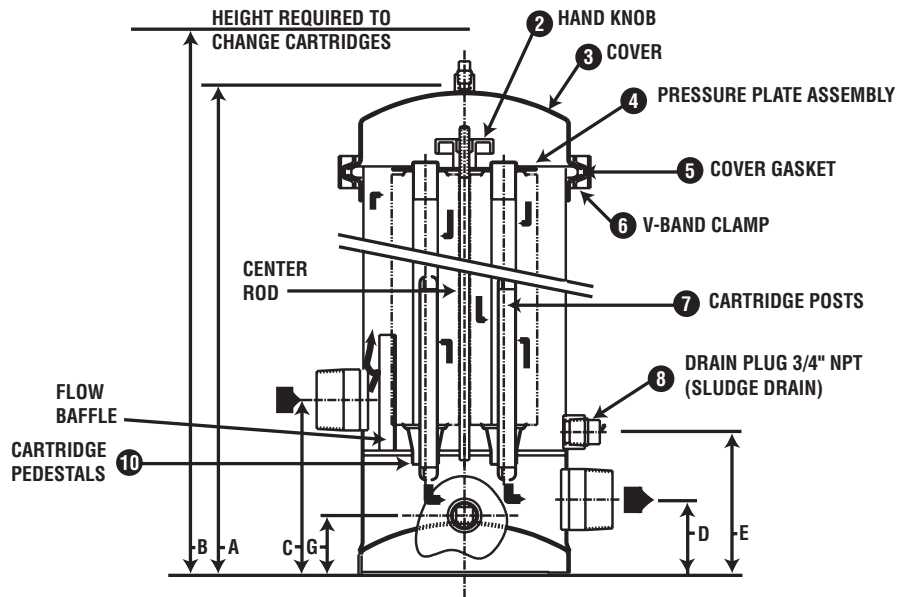

**Elevation View**

(See Plan View for True Orientation)

## 2)Installing the Filter Cartridges

Remove the v-band clamp (item 6). Remove the top cover (item 3). Remove the top cover gasket (item 5) and place on a clean flat surface or hang on a hook. Remove the hand knob (item 2) and lift off the pressure plate (item 4). This will expose the cartridge posts (item 7). Insert the cartridge posts into the cartridge pedestals (item 10) making sure the posts are vertical within the housing. With the cartridge posts in place, gently slide the new filter cartridges over the posts and into position. **CAUTION: DO NOT FORCE, JAM OR DROP IN PLACE. This could damage the filter elements.** Place the pressure plate over the center rod making sure the tube locators are facing down. Engage the locating tubes into all the filter cartridges. While holding the pressure plate down onto the filter cartridges, thread the Hand Knob onto center rod. The knob should then be tightened hand tight.

## 3)Assembling the Filter Housing

After the filter cartridges are installed, locate the top cover gasket and completely wet it with tap water prior to installing it. Install the top cover gasket and the top cover onto the housing. Place the v-band clamp into position over the housing flange and the top cover flange. Be sure it is properly fitting all around housing. Tighten clamp until the housing and cover are properly seated (hand tight). **CAUTION: DO NOT OVERTIGHTEN. Overtightening could result in a cartridge crack which may lead to fluid leaking.**

## 4) Starting Operation

Remove cover vent plug. Slowly and partially open the inlet valve, filling the housing with water. When the water begins to flow from the vent, close the inlet valve and re-install the vent plug. Slowly and completely open the Inlet valve and the lower drain valve until the water runs clear. After the water runs clear, close the lower drain valve and slowly and completely open the outlet valve. Your Aqua-Pure filtration system is now operating. If the filter housing should leak, check all connections including the cover clamping assembly and tighten as necessary.

## 5) Changing the Filter Cartridges

The following procedure should be followed when changing out the cartridges and disassembling the filter housing. Shut off the Inlet valve. Open the nearest faucet down stream of the filter housing to relieve the line pressure, leave this faucet open. Close the outlet valve. Open the upper drain valve, the lower drain valve and the vent plug to drain all water from the housing. After the housing is drained, remove the housing clamp, lift off the top cover, unscrew the hand knob and remove the pressure plate. For single high cartridge filter housings, remove the cartridges and discard. For filter housings with multiple stacked cartridges, remove the top row of cartridges. The top of the cartridge posts will now be visible, grasp each cartridge post and lift to remove any existing cartridges. Discard used cartridges in a suitable container. Clean all parts thoroughly and flush out the housing post for at least 5 minutes to remove any sediment that may have built up during operation. Inspect the condition of the housing cover gasket and replace as necessary.

PROCEED with “Installing the filter cartridges,” “Assembling the filter housing” and “Starting Operation.”

Filter Housing Model	Inlet/Outlet	Dimensions						
		A	B	C	D	E	F	G
SS4 EPE-316L Series	1 1/2" NPT Male	19 1/2" (49.5 cm)	26" (66.0 cm)	6 3/4" (17.1 cm)	2 7/8" (7.3 cm)	5 1/2" (14 cm)	12" (30.5 cm)	2 1/4" (5.7 cm)
SS8 EPE-316L Series	2" NPT Male	29 1/2" (74.9 cm)	46" (116.8 cm)	6 3/4" (17.1 cm)	2 7/8" (7.3 cm)	5 1/2" (14 cm)	12" (30.5 cm)	2 1/4" (5.7 cm)
SS12 EPE-316L Series	2" NPT Male	39 1/2" (100.3 cm)	66" (167.6 cm)	6 3/4" (17.1 cm)	2 7/8" (7.3 cm)	5 1/2" (14 cm)	12" (30.5 cm)	2 1/4" (5.7 cm)
SS20 EPE-316L Series	2" NPT Male	49 1/2" (125.7 cm)	86" (218.4 cm)	6 3/4" (17.1 cm)	2 7/8" (7.3 cm)	5 1/2" (14 cm)	12" (30.5 cm)	2 1/4" (5.7 cm)

## SS4 EPE-316L, SS8 EPE-316L, SS12 EPE-316L & SS20 EPE 316L Filter Housing Replacement Parts List

Item Number	Part Description	Part Number
1	1/4" NPT Vent Plug	6329235
2	Hand Knob	6484031
3	Cover	3787210
4	Pressure Plate Assembly (SS4 EPE-316L, SS8 EPE-316L and SS12 EPE-316L)	6453203
4	Pressure Plate Assembly (SS20 EPE-316L Only)	6453204
5	Cover Gasket (Nitrile)	3792031
6	V-Band Clamp Assembly	3756333
7	1-High Cartridge Post (SS4 EPE-316L)	6681713
7	2-High Cartridge Post (SS8 EPE-316L)	6681714
7	3-High Cartridge Post (SS12 EPE-316L)	6681715
7	4-High Cartridge Post (SS20 EPE-316L)	6681716
8	3/4" NPT Drain Plug	6329238
9	T-bolt Kit (for clamp)	9903104

# SS24-316L, SS36-316L Filter Housing Series

## 1) Installing the Filter Housing (SS24-316L and SS36-316L Filter Housing Series)

Locate the Inlet (marked as "IN" on the flange) and Outlet (marked as "out" on the flange) connections on the housing cylinder. Connect the water supply line piping to the Inlet connection and the filtered water piping serving the building to the Outlet connection. Shut off valves are to be installed on each side of the housing (see Note). DO NOT install the filter housing backwards by connecting the water supply line piping to the Outlet. The drain plugs should then be removed and either a drain line assembly (with two valves) or two hose bibs (faucets) should be installed. See Figure 1 for proper installation. Install filter cartridges per Step 2 prior to filter housing start-up.

**Note:** When the housing is installed in close proximity to the water meter or pressure tank, the main shut off valve may be used for the Inlet water control valve.

**Note:** Installation must comply with state and local plumbing codes.

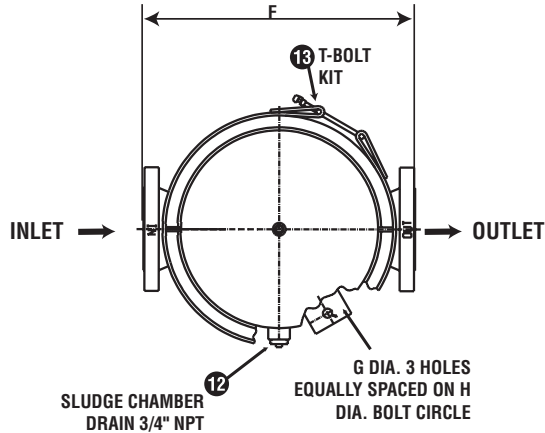

**Plan View**

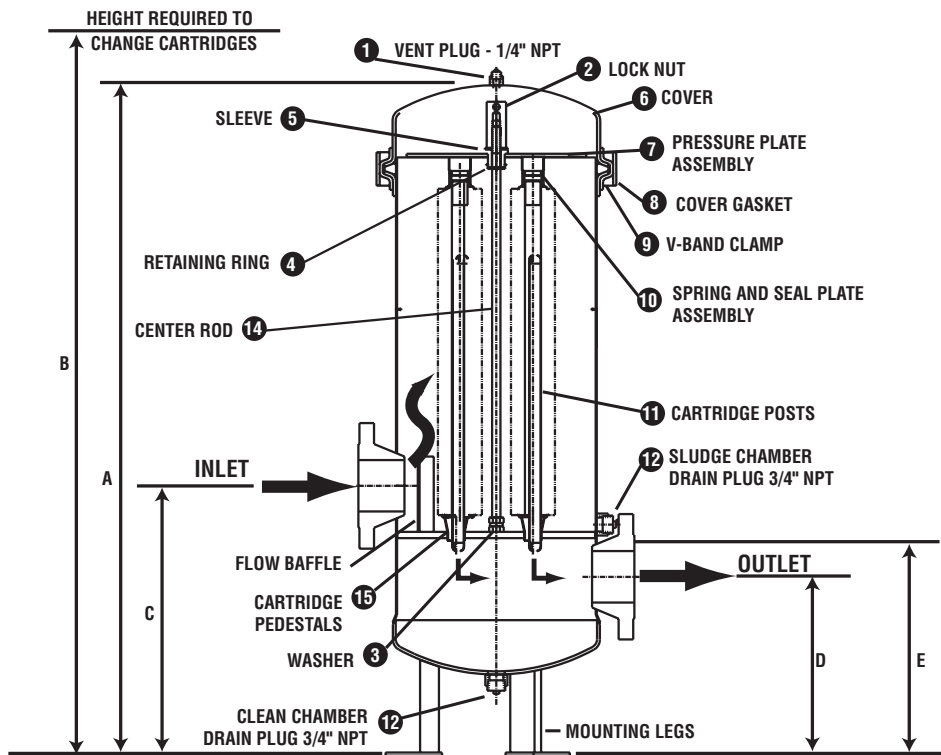

**Elevation View**

(See Plan View for True Orientation)

## 2)Installing the Filter Cartridges

Remove the v-band clamp (item 9). Remove the top cover (item 6). Remove the top cover gasket (item 8) and place on a clean flat surface or hang on a hook. Remove the lock nut (item 2) and lift off the pressure plate (item 7). This will expose the spring and seal plate assemblies (item 10) and cartridge posts (item 11). Carefully pull the spring and seal plate assemblies off the cartridge posts. Inspect the cartridge posts to make sure that they are inserted into the cartridge pedestals (item 15) and that the posts are vertical within the housing. With the cartridge posts in place, gently slide the new filter cartridges over the posts and into position. **CAUTION: DO NOT FORCE, JAM OR DROP IN PLACE.** This could damage the filter elements. Carefully place each spring and seal plate assembly tube facing down onto each cartridge. Make sure the sleeve (item 5) and retaining ring (item 4) are still attached to the pressure plate. Place the pressure plate over the center rod (item 14) onto the spring and seal plate assemblies. Thread the lock nut onto center rod and tighten securely.

## 3)Assembling the Filter Housing

After the filter cartridges are installed, locate the top cover gasket and completely wet it with tap water prior to installing it. Install the top cover gasket and the top cover onto the housing. Place the v-band clamp into position over the housing flange and the top cover flange. Be sure it is properly fitted all around the housing. Tighten clamp until the housing and cover are properly seated. Approximately 1" to 1 1/8" of the threads should show past the T-Bolt Nut (16 - 17 ft. lbs.). **CAUTION: DO NOT OVERTIGHTEN. Overtightening could result in a cartridge crack which may lead to fluid leaking.**

## 4)Starting Operation

Remove cover vent plug. Slowly and partially open the Inlet valve, filling the housing with water. When the water begins to flow from the vent, close the inlet valve and re-install the vent plug. Slowly and completely open the Inlet valve and lower drain valve until the water runs clear. After the water runs clear, close the lower drain valve and slowly and completely open the outlet valve. Your Aqua-Pure filtration system is now operating. If the filter housing should leak, check all connections including the cover clamping assembly and tighten as necessary.

## 5)Changing The Filter Cartridges

The following procedure should be followed when changing out the cartridges and disassembling the filter housing. Shut off the Inlet valve. Open the upper drain valve, the lower drain valve and the vent plug to drain all water from the housing. After the housing is drained, remove the housing clamp, lift off the top cover, unscrew the Lock Nut and remove the pressure plate and spring and seal plate assemblies. Remove the top row of cartridges. The top of the cartridge posts will now be visible, grasp each cartridge post and lift to remove the existing cartridges. Discard used cartridges in a suitable container. Clean all parts thoroughly and flush out the housing to remove any sediment that may have built up during operation. Inspect the condition of the housing cover gasket and replace as necessary.

Filter Housing Model	Inlet/Outlet	Dimensions							
		A	B	C	D	E	F	G	H
SS24 EPE-316L Series	3" - 150# Flange	40 9/16" (103.0 cm)	57 1/2" (146.1 cm)	16 1/8" (41 cm)	10 11/16" (27.2 cm)	13 13/16" (35.1 cm)	16 1/2" (41.9 cm)	9/16" (1.4 cm)	11 3/4" (29.8 cm)
SS36 EPE-316L Series	3" - 150# Flange	50 7/16" (74.9 cm)	77" (116.8 cm)	16 1/8" (17.1 cm)	10 11/16" (7.3 cm)	13 13/16" (14 cm)	16 1/2" (30.5 cm)	9/16" (1.4 cm)	11 3/4" (29.8 cm)

## SS24 EPE-316L & SS36 EPE 316L Filter Housing Replacement Parts List

Item Number	Part Description	Part Number
1	1/4" NPT Vent Plug	6329235
2	Lock Nut	6347903
3	Washer	6318731
4	Retaining Ring	8913939
5	Sleeve	6346832
6	Cover	6376738
7	Pressure Plate Assembly	6346443
8	Cover Gasket (Nitrile)	6347532
9	V-Band Clamp Assembly	3756335
10	Spring and Seal Plate Assembly	6343707
11	2-High Cartridge Post (SS24 EPE-316L Series)	6681706
	3-High Cartridge Post (SS36 EPE-316L Series)	6681707
12	3/4" NPT Drain Plug	6329238
13	T-bolt Kit (for clamp)	9903107
14	2-High Center Rod (SS24 EPE-316L Series)	6346206
	3-High Center Rod (SS36 EPE-316L Series)	6346207

		CARTRIDGE INCLUDED			SS MATERIAL	
SS4 EPE - 316L	55278-13			X	X	X
SS8 EPE - 316L	55278-14			X	X	X
SS12 EPE - 316L	55278-15			X	X	X
SS20 EPE - 316L	55007-03			X	X	X
SS24 EPE - 316L	55008-10			X	X	X
SS36 EPE - 316L	55008-11			X	X	X

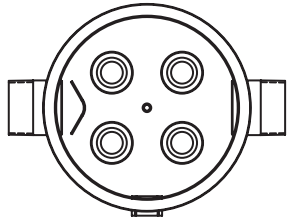

**SS4 EPE-316L Series**  
**SS8 EPE-316L Series**  
**SS12 EPE-316L Series**

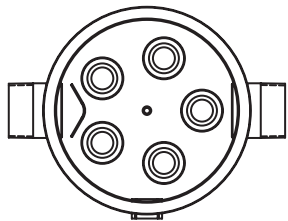

**SS20 EPE-316L Series**

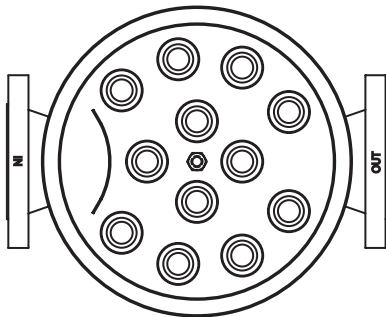

**SS24 EPE-316L Series**  
**SS36 EPE-316L Series**

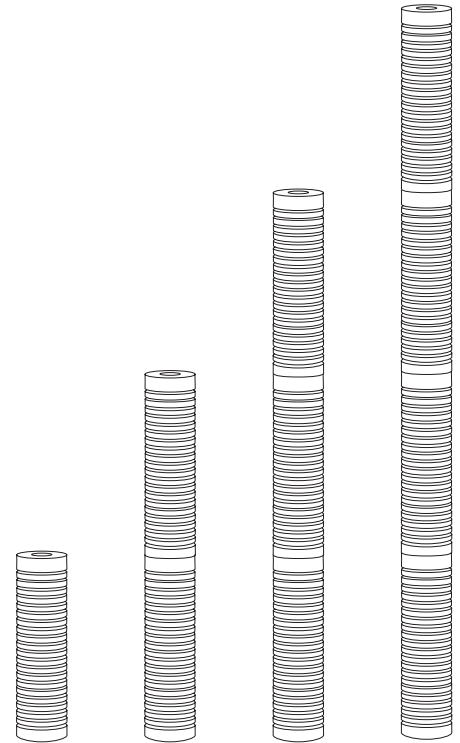

<b>Suffix</b>	N/A	-2	-3	-4
<b>Length</b>	9 3/4"	19 1/2"	29 1/4"	39"

<b>Suffix</b>	N/A	-2C	-3C	-4C
<b>Length</b>	10"	20"	30"	40"

**Limited Warranty**

CUNO Incorporated, a 3M Company, warrants that this product is free from defects in materials and workmanship. This warranty, together with any and all warranties implied by law, shall be limited to a period of ten (10) years from the date of original purchase. This warranty does not apply to failures that result from abuse, misuse, alteration or damage not caused by CUNO or failure to properly comply with the installation or cartridge change-out instructions. This warranty is subject to exclusions and limitations. Please refer to the Warranty Card provided with the product for details.

CUNO and Aqua-Pure are trademarks of 3M Company used under license.



CUNO Incorporated  
 400 Research Parkway  
 Meriden, CT 06450, USA  
 Toll Free: 1-800-222-7880  
 Worldwide: 203-237-5541  
 Fax: 203-238-8701