

Integrity Testing LifeASSURE™ BNA045 and BNA065 Series Filter Cartridges

SAFETY INFORMATION

Read, understand, and follow all safety information contained in these instructions and the instructions provided with the original filtration system, prior to installation and use. Retain for future reference.

EXPLANATION OF SIGNAL WORD CONSEQUENCES	
⚠ WARNING:	Indicates a potentially hazardous situation, which, if not avoided, could result in death or serious injury and/or property damage.
⚠ CAUTION:	Indicates a potentially hazardous situation which, if not avoided, may result in minor or moderate injury and/or property damage.

⚠ WARNING:
<p>To reduce the risk associated with system burst related injuries:</p> <ul style="list-style-type: none"> • Do not use if fluid pressure exceeds rating described on the pressure vessel data plate. • Do not use with fluids at temperatures exceeding the rating described on the pressure vessel data plate. • Do not use for continuous service with compressed gases.

⚠ CAUTION:
<p>To reduce the risk associated with exposure to contaminants:</p> <ul style="list-style-type: none"> • Always use appropriate personal protective equipment (PPE) when installing or servicing the filtration system. • Ensure that all system pressure has been relieved prior to opening the system to atmosphere. • To reduce the risk associated with eye, skin, and respiratory and digestive tract injuries from chemical cleaners/sanitizers during system maintenance: <ul style="list-style-type: none"> ○ Do not get chemical cleaners/sanitizers in eyes, on skin, or on clothing. Do not ingest or inhale. ○ Wear appropriate PPE including eye and face protection, protective gloves, and an appropriate NIOSH-approved filter mask.

INTRODUCTION

The integrity test is a non-destructive method for the End User to confirm the structural integrity of a LifeASSURE™ BNA045 or BNA065 series filter cartridge before and after use. An “in specification” result confirms the porosity of the filter cartridge membrane and that the filter cartridge is structurally integral. Three methods can be employed to integrity test hydrophilic (water wettable) LifeASSURE BNA045 and BNA065 series filter cartridges. These methods are:

1. Forward Flow Integrity Test (FFIT)
2. Bubble Point Test (BPT)
3. Pressure Hold Test (PHT)

All three integrity tests can be performed manually or with the CUNOCheck™ 2 Automated Integrity Tester. For more information about using the CUNOCheck 2 tester to perform an integrity test, refer to the CUNOCheck 2 Operator Manual (70-0201-8694-9).

Prior to performing an integrity test, the filter membrane must be thoroughly wet with water or the Customer's fluid that will be filtered. Internal testing has shown that the LifeASSURE™ BNA045 and BNA065 membranes are easily wet with water. Any of the following three methods may be used to ensure the filter membrane is thoroughly wet prior to the integrity test:

Method 1.

With the housing vent valve open and the downstream valve slightly opened or completely closed, fill the housing with water. When water begins to exit through the housing vent valve, close the vent valve, close the downstream valve and stop the flow of water into the housing. Allow the water to remain in the housing for approximately 5 minutes to statically wet the filter cartridges. Open the vent valve and the housing drain valve or the downstream valve and drain the housing. Perform the required integrity test.

Method 2.

With the housing vent valve open and the downstream valve slightly opened or completely closed, fill the housing with water. When water begins to exit through the housing vent valve, close the vent valve and open the downstream valve. Flow water through the housing for approximately 5 minutes at 3 gpm per 10" filter cartridge with no downstream back pressure. Open the vent valve and the housing drain valve or the downstream valve and drain the housing. Perform the required integrity test.

Method 3.

With the housing vent valve open and the downstream valve completely closed, fill the housing with water. When water begins to exit through the housing vent valve, close the vent valve. Initiate water flow into the housing at a minimum of 50 psi supply pressure. Let the water continue to flow into the housing and leave the housing under these pressure conditions for 5 minutes. After 5 minutes, slowly open the downstream valve and allow water to flow through the housing for approximately 2 minutes at a minimum water flow rate of 0.5 lpm per 10" filter cartridge. Open the vent valve and the housing drain valve or the downstream valve and drain the housing. Perform the required integrity test.

FORWARD FLOW INTEGRITY TEST

Definition

According to Fick's Law of Diffusion, when a differential gas pressure exists across a wetted membrane, the gas molecules will "diffuse" through the water filling the pores of the membrane. The rate of passage is proportional to the solubility of the gas in the wetting fluid, the surface tension of the wetting fluid, the differential pressure, the thickness of the membrane, the pore size, and the surface area of the membrane. The diffusion rate is measured at a pressure below the membrane bubble point pressure. If no bulk flow exists, there are no pores large enough to compromise the filter cartridge's integrity. The Forward Flow Integrity Test (FFIT) may be employed with a multi-cartridge filter housing.

Procedure 1. Forward Flow Integrity Test (Manual Method)

- A. Configure the system as shown in Figure 1.
- B. Install the filter cartridge(s) in the housing and thoroughly wet the filter cartridge(s) with clean, ambient temperature, filtered water using one of the three wetting procedures indicated.
- C. Close inlet valve V1 and outlet valve V6 to isolate the housing. Drain all the water from the upstream side of the filter cartridge by positioning V5 to direct flow to drain. Adjust the pressure regulator to deliver 3 – 5 psig of air (**DO NOT USE CO₂**)*. Slowly open V3. Close V3 when water discharge is no longer evident.
- D. Connect one end of a flexible tube to the outlet port V5 and submerge the other end in a container of water. Position V5 to direct flow to the container of water.

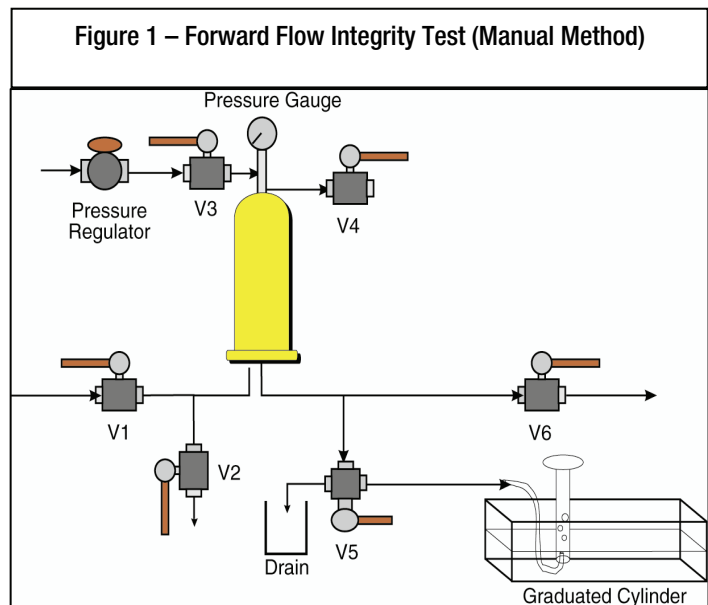

* Use of CO₂ in the integrity test will result in a false reading.

- E. Open V3 and slowly adjust the pressure regulator to pressurize the system to the specified FFIT test pressure value and allow the system to equilibrate for a minimum of one minute, or until steady bubbling is seen from the submersed end of the tube.
- F. Place the opening of the tube under an inverted graduated cylinder or burette (calibrated in milliliters or cubic centimeters) of an appropriate size filled with and submersed under sterile water.
- G. Measure the air flow for 5 minutes. Calculate the diffusion rate in cc/min.
- H. When the test is complete, compare the result to the filter cartridge FFIT specification.
- I. After the test is complete, drain the water from the housing and place the filter cartridge back in service.
- J. If the diffusion rate is higher than the specification, consider following questions and re-test if necessary:
 - Was the filter cartridge completely wet out?
 - Was the correct pore size filter cartridge installed?
 - Was the temperature of the water and filter cartridge ambient?
 - Was the stabilization time adequate?
 - Was the test time adequate?
 - Was the filter cartridge seated correctly in the housing and were the o-rings undamaged?
 - Are there any leaks on the upstream side of the filter cartridge?

LifeASSURE Filter Cartridge Grade	Test Pressure Psi / bar	Maximum Forward Flow Integrity Valve – cc/min 10" filter cartridge
BNA045	22 psi / 1.5 bar	≤ 35 cc/min @ 25°C
BNA065	15 psi / 1.0 bar	≤ 25 cc/min @ 25°C

Procedure 2. Forward Flow Integrity Test (Automated Method)

- A. Configure the system as shown in Figure 2.
- B. Install the filter cartridge(s) in the housing and thoroughly wet the filter cartridge(s) with clean, ambient temperature, filtered water using one of the three wetting procedures indicated.
- C. Close inlet valve V1 and outlet valve V6 to isolate the housing. Drain all the water from the upstream side of the filter cartridge by positioning V5 to direct flow to drain. Adjust the pressure regulator to deliver 3 – 5 psig of air (**DO NOT USE CO₂**)*. Slowly open V3. Close V3 when water discharge is no longer evident.

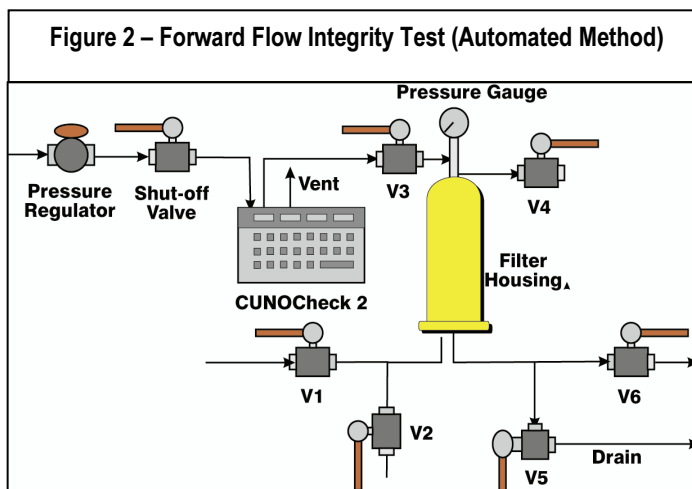

- D. Close the housing inlet valve V1 and connect the CUNOCheck 2 Automated Integrity Tester at V3.
- E. Initiate the automated Forward Flow Integrity Test program.
- F. When the test is complete, compare the measured FFIT value to the acceptable limit for the filter cartridge under test.
- G. After the test is complete, drain the water from the housing and place the filter cartridge back in service.
- H. Disconnect the CUNOCheck 2 Automated Integrity Tester from the housing.

* Use of CO₂ in the integrity test will result in a false reading.

BUBBLE POINT TEST (Refer to Figure 3)

Definition

The bubble point is the minimum gas pressure required to overcome the surface tension holding water in a membrane filter cartridge's pores.

The bubble point pressure measurement is **only recommended** for single 10-inch or smaller filter cartridge and capsule filter cartridges. When more filter area is online, it can become difficult to distinguish diffusional flow from the true bulk flow which occurs at the bubble point pressure. For systems with two or more 10-inch equivalent filter cartridges, Forward Flow or Pressure Hold measurements are recommended.

The CUNOCheck 2 Automated Integrity Tester can be used to perform a bubble point test. When using the CUNOCheck 2 tester, follow the installation instructions for connecting the unit to the upstream valve as shown in Figure 4. Consult the table at the end of Procedure 3 for the appropriate filter cartridge bubble point value.

Procedure 3. Bubble Point Test (Manual Method)

- A. Configure the system as shown in Figure 3.
- B. Install the filter cartridge(s) in the housing and thoroughly wet the filter cartridge(s) with clean, ambient temperature, filtered water using one of the three wetting procedures of indicated.
- C. Close inlet valve V1 and outlet valve V6 to isolate the housing. Drain all the water from the upstream side of the filter cartridge by positioning V5 to direct flow to drain. Adjust the pressure regulator to deliver 3 – 5 psig of air (**DO NOT USE CO₂**)*. Slowly open V3. Close V3 when water discharge is no longer evident.
- D. Connect a tube from the outlet port V5 to a container of water.
- E. Open V3. Using the pressure regulator, slowly pressurize the system with air (DO NOT USE CO₂), raising the pressure 5 psi (0.34 bar) per minute. When within 5 psi (0.34 bar) of the expected bubble point pressure, make only very gradual 1 psi (0.07 bar) increases allowing 5 - 10 seconds between pressure increases to observe evidence of bubbling.
- F. Observe any air flow from the tube connected to the downstream port. A modest flow of small bubbles is diffusion flow only. When a continuous flow of large bubbles appears, the filter cartridge's bubble point has been reached.
- G. When the test is complete, compare the measured bubble point value against the acceptable limit for the filter cartridge under test.
- H. After the test is complete, drain the water from the housing and place the filter cartridge back in service.
- I. If the bubble point is less than the recommended value, consider the following questions and re-test if necessary:
 - Was the filter cartridge completely wet out?
 - Was the correct pore size filter cartridge installed?
 - Was the temperature of the water and filter cartridge ambient?
 - Was the stabilization time adequate?

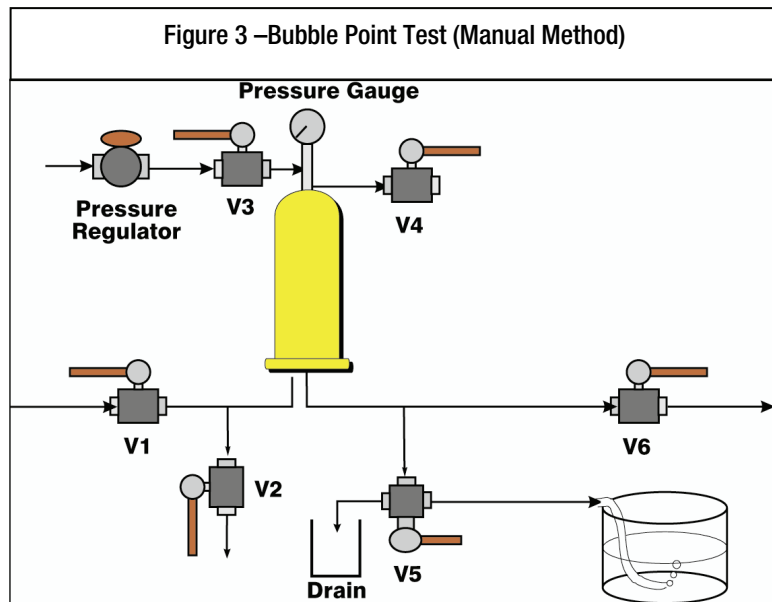

* Use of CO₂ in the integrity test will result in a false reading.

- Was the test time adequate?
- Was the filter cartridge seated correctly in the housing and were the o-rings undamaged?
- Are there any leaks on the upstream side of the filter cartridge?

LifeASSURE™ Filter Cartridge Grade	Minimum Bubble Point Pressure – psi / bar
	10" filter cartridge
BNA045	≥ 24 psi / 1.8 bar
BNA065	≥ 17 psi / 1.2 bar

Procedure 4. Bubble Point Test (Automated Method)

- A. Configure the system as shown in Figure 4.
- B. Install the filter cartridge(s) in the housing and thoroughly wet the filter cartridge(s) with clean, ambient temperature, filtered water using one of the three wetting procedures indicated.
- C. Close inlet valve V1 and outlet valve V6 to isolate the housing. Drain all the water from the upstream side of the filter cartridge by positioning V5 to direct flow to drain. Adjust the pressure regulator to deliver 3 – 5 psig of air (DO NOT USE CO₂). Slowly open V3. Close V3 when water discharge is no longer evident.

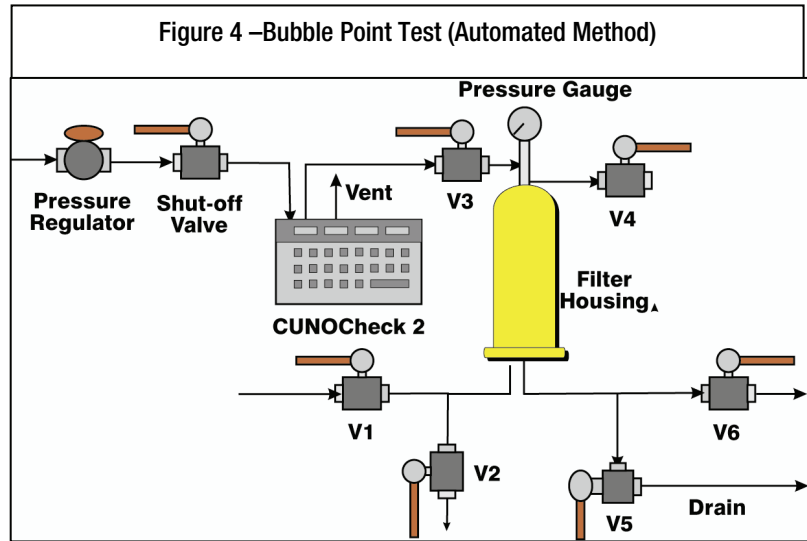

- D. Disconnect the water supply line and allow the water to drain from the housing. Leave V5 or V6 open to atmosphere.
- E. Close V1 and connect the CUNOCheck 2 Automated Integrity Tester at V3.
- F. In the Program Test, Edit File programming mode, set the Max. Pressure Drop to 0.4 psig.
- G. Initiate the automated Bubble Point Test Program.
- H. When the test is complete, compare the measured BPT value against the acceptable limit for the filter cartridge under test.
- I. After the test is complete, drain the water from the housing and place the filter cartridge back in service.
- J. Disconnect the CUNOCheck 2 Automated Integrity Tester from the housing.

NOTE: It is important to make an aseptic connection and to close the outlet port immediately after the system has been integrity tested to prevent contamination.

Procedure 5. PRESSURE HOLD TEST

Definition

A variation of the FFIT is the Pressure Hold Test (PHT). Instead of measuring the diffusion rate of gas across the membrane, the PHT uses a sensitive pressure gauge to measure the decay of pressure in a closed volume on the upstream side of the membrane as the gas diffuses through the wetted membrane. PHT values are dependent on the volume of the specific filter cartridge housing employed, less the volume of the installed filter cartridges. Therefore, they must be determined on a case by case basis. Please contact 3M Purification Technical Service for assistance, if necessary.

* Use of CO₂ in the integrity test will result in a false reading.

The CUNOCheck™ 2 Automated Integrity Tester can be used to perform a pressure hold test. When using the CUNOCheck 2 tester, follow the installation instructions for connecting the unit to the upstream valve as shown in Figure 6. Consult the table on page 6 for the appropriate test pressure. Consult 3M Purification for the appropriate PHT value for your filter cartridge housing. Program these values into the CUNOCheck 2 tester when requested during the test set-up.

The PHT uses the following equation:

$$\frac{\Delta P}{T} = \frac{K(Pa)}{V_{hsg}}$$

Pa = Manufacturer's maximum allowable diffusion rate for all the installed filter cartridges in cc/min (see Forward Flow Integrity specifications)

T = Time (typically 5 minutes)

K = Atmospheric pressure

V_{hsg} = Upstream housing volume (cc) less the volume occupied by the filter cartridge(s)

P = Allowable pressure loss

Procedure 6. Pressure Hold Test (Manual Method)

- A. Configure the system as shown in Figure 5.
- B. Install the filter cartridge(s) in the housing and thoroughly wet the filter cartridge(s) with clean, ambient temperature, filtered water using one of the three wetting procedures indicated.
- C. Close inlet V1 and outlet valve V6 to isolate the housing. Drain all the water from the upstream side of the filter cartridge by positioning V5 to direct flow to drain. Adjust the pressure regulator to deliver 3 – 5 psig of air (**DO NOT USE CO₂**). Slowly open V3. Close V3 when water discharge is no longer evident.
- D. Disconnect the water supply line and allow the water to drain from the housing. Leave V5 or V6 open to atmosphere.
- E. Open V3 and slowly adjust the pressure regulator to pressurize the system to the specified PHT pressure value and allow the system to equilibrate for a minimum of two minutes.
- F. Using a stopwatch, measure the pressure decay for 5 minutes. Calculate the pressure decay over the 5 minute period in psi/min.
- G. When the test is complete, compare the result to the filter cartridge PHT specification.
- H. After the test is complete, drain the water from the housing and place the filter cartridge back in service.
- I. If the pressure decay is higher than the specification, consider following questions and re-test if necessary:

- Was the filter cartridge completely wet out?
- Was the correct pore size filter cartridge installed?
- Was the temperature of the water and filter cartridge ambient?
- Was the stabilization time adequate?
- Was the test time adequate?
- Was the filter cartridge seated correctly in the housing and were the o-rings undamaged?
- Are there any leaks on the upstream side of the filter cartridge?

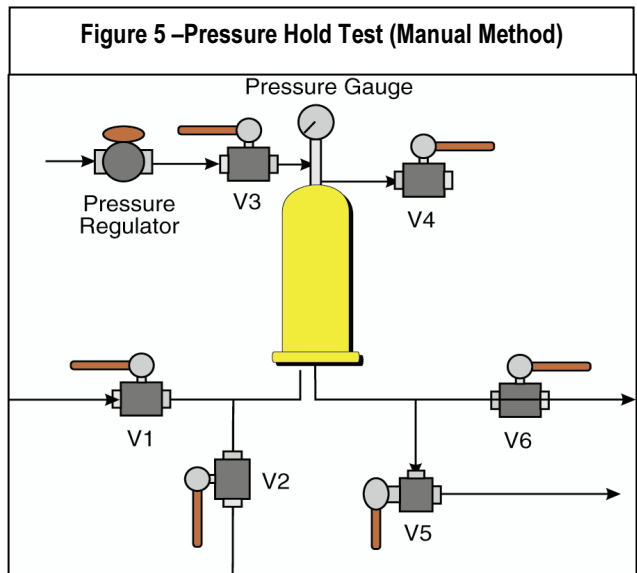

LifeASSURE™ Filter Cartridge Grade	Test Pressure	Allowable Pressure Decay
	psi / bar	psi/min. (bar/min.)
BNA045	22 psi / 1.5 bar	Consult 3M Purification Inc.
BNA065	15 psi / 1.0 bar	Consult 3M Purification Inc.

* Use of CO₂ in the integrity test will result in a false reading.

Procedure 7. Pressure Hold Test (Automated Method)

- A. Configure the system as shown in Figure 6.
- B. Install the filter cartridge(s) in the housing and thoroughly wet the filter cartridge(s) with clean, ambient temperature, filtered water using one of the three wetting procedures indicated.
- C. Close inlet V1 and outlet valve V6 to isolate the housing. Drain all the water from the upstream side of the filter cartridge by positioning V5 to direct flow to drain. Adjust the pressure regulator to deliver 3–5 psig of air (**DO NOT USE CO₂**). Slowly open V3. Close V3 when water discharge is no longer evident.

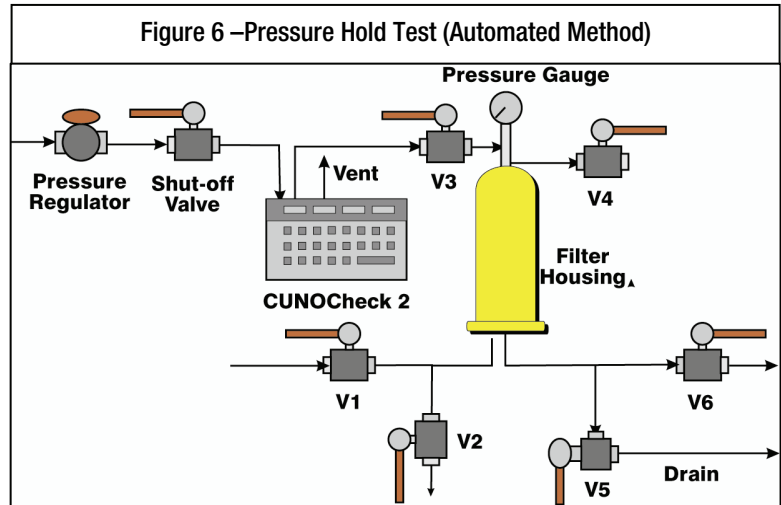

- D. Disconnect the water supply line and allow the water to drain from the housing. Leave V5 or V6 open to atmosphere.
- E. Close V1 and connect the CUNOCheck 2 Automated Integrity Tester at V3.
- F. Initiate the automated Pressure Hold Integrity Test program.
- G. When the test is complete, compare the measured PHT value against the acceptable limit for the filter cartridge under test.
- H. After the test is complete, drain the water from the housing and place the filter cartridge back in service.
- I. Disconnect the CUNOCheck 2 Automated Integrity Tester from the housing.

NOTE: It is important to make an aseptic connection and to close the outlet port immediately after the system has been integrity tested to prevent contamination.

* Use of CO₂ in the integrity test will result in a false reading.

Important Notice:

The test results described in this literature are accurate to the best of our knowledge. A variety of factors, however, can affect the performance of the product(s) in a particular application, some of which are uniquely within your knowledge and control. **INFORMATION IS SUPPLIED UPON THE CONDITION THAT THE PERSONS RECEIVING THE SAME WILL MAKE THEIR OWN DETERMINATION AS TO ITS SUITABILITY FOR THEIR USE. IN NO EVENT WILL 3M PURIFICATION INC. BE RESPONSIBLE FOR DAMAGES OF ANY NATURE WHATSOEVER RESULTING FROM THE USE OF OR RELIANCE UPON INFORMATION.**

It is your responsibility to determine if additional testing or information is required and if the 3M Purification Inc. product is fit for a particular purpose and suitable in your specific application.

3M PURIFICATION INC. MAKES NO REPRESENTATIONS OR WARRANTIES, EITHER EXPRESS OR IMPLIED INCLUDING WITHOUT LIMITATION ANY WARRANTIES OF MERCHANTABILITY, FITNESS FOR A PARTICULAR PURPOSE OR OF ANY OTHER NATURE HEREUNDER WITH RESPECT TO INFORMATION OR THE PRODUCT TO WHICH INFORMATION REFERS.

Limitation of Liability:

3M Purification Inc. will not be liable for any loss or damage arising from the product(s), whether direct, indirect, special, incidental, or consequential, regardless of the legal theory asserted, including warranty, contract, negligence or strict liability. Some states and countries do not allow the exclusion or limitation of incidental or consequential damages, so the above limitation or exclusion may not apply to you.



3M Purification Inc.
400 Research Parkway
Meriden, CT 06450
U.S.A.
(800) 243-6894
(203) 237-5541
Fax (230) 630-4530
www.3mpurification.com

3M is a trademark of 3M Company.
CUNOCheck and LifeASSURE are trademarks of 3M Company used under license.
All other trademarks are the property of their respective owners.
© 2010. 3M Company. All rights reserved
70-0202-6597-4 REV 1110