

3M™ LifeASSURE™ PLA Series Filters

Filters for Pharmaceutical and Biological Service

3M™ LifeASSURE™ PLA series filters are 3M's latest advance in membrane filter technology. Encompassing two leading-edge processes, multi-zone microporous membrane manufacture and Advanced Pleat Technology (APT) pleating construction, the 3M LifeASSURE PLA series filters offers unmatched protection of final membrane filters, as well as exceptionally long service life. Designed with pleated Nylon 6,6 membrane in an all-polypropylene construction, 3M LifeASSURE PLA series filters are ideally suited for a wide range of pre-filtration and clarification applications in the pharmaceutical, biological, and bioprocess industries.

Optimal System Performance

Used as a prefilter, 3M LifeASSURE PLA series filters help protect and significantly extend the service life of 3M's sterilizing grade 3M™ LifeASSURE™ PSA series final filter, as well as other membrane filters. 3M LifeASSURE PLA series filters will:

- Increase final filter life substantially, often by 10 times or more.
- Decrease filter change-outs, greatly reducing filter costs.
- Provide superior microorganism reduction.



Multi-Zone Microporous Membrane Technology

3M LifeASSURE PLA series filters incorporate advanced multi-zone microporous membrane technology. It allows unmatched flexibility in creating a multi-zone membrane that offers the maximum in contaminant holding capacity while maintaining high retention efficiency. The SEM photograph on page two shows that the single layer 3M LifeASSURE PLA series filter membrane consists of an “open” zone on the upstream side of the membrane and a “tighter” zone on the downstream side. In effect, the open zone acts as a prefilter by capturing larger particles and colloids while the tighter zone provides the retention of smaller contaminants. This multi-zone structure eliminates dual-layer membrane construction to provide a larger surface area, significantly increased contaminant holding capacity, and longer service life than competitive filters. For an in-depth technical presentation of multi-zone microporous membrane technology, request 3M Technical Publication 70-0201-8812-7, or visit www.3Mpurification.com.

Features & Benefits

Multi-zone microporous nylon membrane

- Maximum membrane protection
- Extended service life
- Increased contaminant capacity
- Lower total filtration cost

Advanced Pleat Technology for extremely high surface area

- Faster flow rates and smaller filter assemblies than competitive filters
- Lower total filtration costs than competitive filters

100% Integrity tested in manufacturing

- Ensures product quality

Installation integrity testable by the user

- Ensures proper installation and operation

True membrane construction

- Superior removal of microorganisms

Meets the requirements of USP Class VI Biological Test for Plastics

- Complies with requirements of The Pure Food, Drug, and Cosmetic Act for contact with food.

Applications

3M™ LifeASSURE™ PLA series filters are designed for a broad range of aqueous based pharmaceutical, biological and bioprocess pre-filtration and fine particle removal applications, including:

- 0.20 µm final sterilizing filter protection
- Parenterals (SVP, LVP)
- Reagents and buffers
- Vaccines
- Serum and blood fractions
- Particulate and Bioburden Reduction
- Cell culture fluids
- Fermenter feed streams
- Solvent filtration
- High-Purity DI Water and WFI Systems
- Ophthalmics
- Orals and topicals

The Advanced Pleat Technology (APT) Advantage

3M LifeASSURE PLA series filters also feature 3M's APT construction for extended service life. This design technology maximizes the useful surface area of the filter while maintaining proper flow paths between media pleats. By employing as much as 50% more effective surface area* than competitive filters (see chart 1), the 3M LifeASSURE PLA series filters provides lower pressure drops, longer service life and lower overall filtration costs.

Superior Microorganism Removal

3M LifeASSURE PLA series filters consistently exhibit a greater reduction of microorganisms than competitive filters that are constructed of polypropylene fibers, or filters that are constructed with less efficient membranes.

For effective prefiltration of pharmaceutical and biological products, microorganism reduction is a critical parameter resulting in economical, reliable filter systems. 3M LifeASSURE PLA020 grade filters ensure compliance with your GMP requirements to maintain low system bioburden.

In tests with *Brevundimonas diminuta*, (considered one of the smallest bacteria) 3M LifeASSURE PLA020 series grade filters exhibited an average log reduction value** (LRV) of 7.3 and the 3M LifeASSURE PLA045 grade filters exhibited an average LRV of 3.5.

3M LifeASSURE PLA Series Prefilter and 3M™ LifeASSURE™ PSA Series Final Filter System Filtration Advantage

Chart 2 shows the significant throughput advantage of the 3M LifeASSURE PLA series prefilter/3M™ LifeASSURE™ PSA series final filter combination compared to competitive prefilter/final filter selections. The throughput advantage is the result of multi-zone microporous membrane construction. 3M LifeASSURE PLA080 series (0.8 micron) filters contain an upstream zone of 2.5 micron and a downstream zone of 0.8 micron.

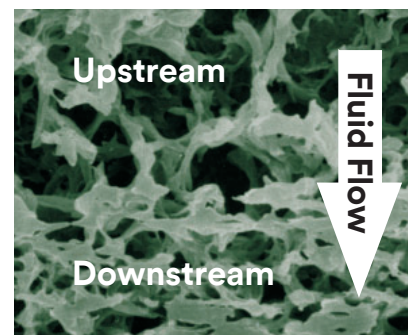

Table 1 - Comparative Log Reduction Values

| Products | LRV |
|---------------------------|------|
| 3M™ LifeASSURE™ PLA020 | 7.3 |
| Millipore Milligard® CWSS | 4.5 |
| 3M™ LifeASSURE™ PLA045 | 3.5 |
| Millipore Milligard® CWSC | 2.6 |
| Pall HDC® J006 | 0.41 |

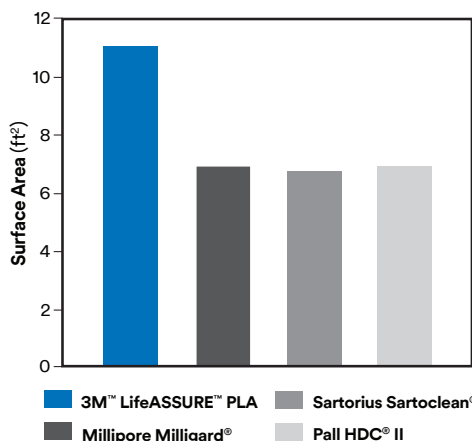

Chart 1. Surface Area Comparison

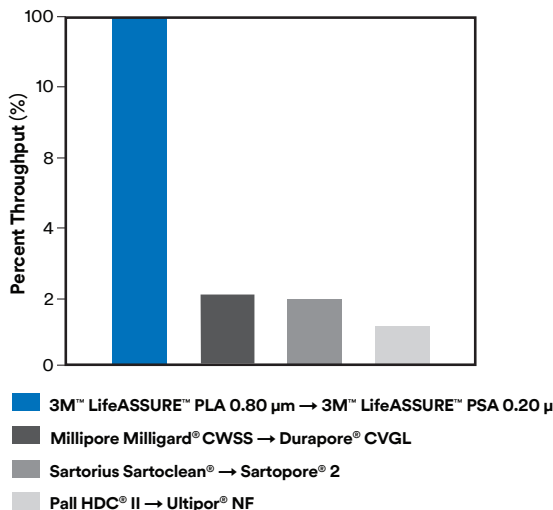

Chart 2. Prefilter - Final Filter Throughput Comparison Using A Model Contaminant Solution Out Performed Competitive Filter Systems By Up To 5 Times.

* Competitive filter surface area data are from the manufacturers' published literature.

** LRV = log₁₀ (number of organisms in/number of organisms out).

Filters for Pharmaceutical and Biological Service

3M™ LifeASSURE™ PSA020 Series (0.20 micron) contain an upstream zone of 0.65 micron and a downstream zone of 0.20 micron. The result of this combination is superior system throughput. Finer grades of 3M™ LifeASSURE™ PLA series prefilters may be required to protect competitive 0.20 micron rated final filters. For best results, please consult 3M Purifications Inc. Sales Specialists.

For optimum throughput, use 3M LifeASSURE PLA series 0.80 µm rated filters upstream of 3M LifeASSURE PSA series 0.20 µm rated filters, and 3M LifeASSURE PLA series 0.45 µm rated filters upstream of 3M LifeASSURE PSA series 0.1 µm rated filters.

We encourage you to experience the 3M performance advantage by arranging an on-site filter test. For more information about testing and 3M LifeASSURE PSA series filters, document 70-0201-8893-7, contact your 3M Sales Specialist or local Distributor.

Higher Flow At A Lower Pressure Drop Reduces Filter Cost Two Ways:

Change-Out Filters Less Frequently — For existing applications at a given flow rate, filters with more surface area per filter have a lower flux (flow per unit surface area) than those filters with less surface area. Since service life is inversely proportional to flux (lower flux = longer service life) in most applications, 3M LifeASSURE PLA series filters provide longer service life and require fewer filter change-outs. This greatly reduces filter costs, disposal costs, CIP/SIP, labor and downtime.

Use Smaller, More Efficient 3M Series Filter Systems - For new applications where filter housing size is selected based on a desired “clean” initial pressure drop, filters that provide a higher flow rate per filter at a given pressure drop will require fewer filters. A smaller filter housing will be required to complete the task, resulting in a substantial reduction in system costs.

Benefits of Higher Per-Cartridge Flow Rates

The relative water flow rate performance of 3M LifeASSURE PLA series prefilter and 3M LifeASSURE PSA series final filter was compared to conventional prefilter and final filter combinations commonly used by pharmaceutical manufacturers. The combined pressure drop of 10" 3M LifeASSURE PLA/PSA series filter systems for a 3 gallon per minute (11.4 lpm) water flow rate is compared to competitive 10" filter systems in Table 2. The results of water flow versus differential pressure testing show a combined system flow rate/pressure drop of less than 1/2 that of competitive filter systems.

Table 2 - Combined Prefilter/Final Filter Pressure Drop Comparison

| Prefilter | Final Filter | Pressure Drop (psid) |
|-------------------------------|-------------------------------|----------------------|
| 3M™ LifeASSURE™ PLA080 Series | 3M™ LifeASSURE™ PSA020 Series | 3.25 |
| 3M™ LifeASSURE™ PLA045 Series | 3M™ LifeASSURE™ PSA020 Series | 3.5 |
| Millipore Milligard® CWSS | Millipore Durapore® CVGL | 7.25 |
| Pall HDC® J006 | Pall Ultipor® NF | 7.4 |

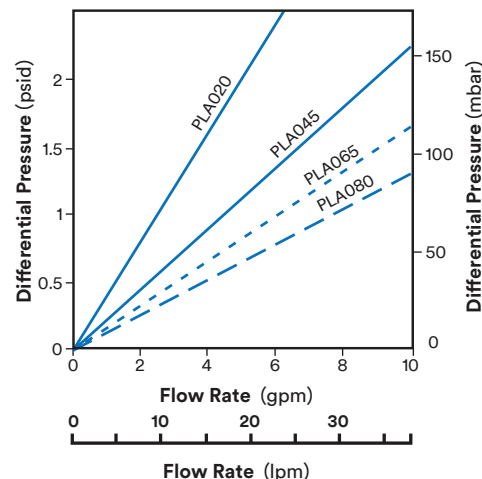

Chart 3. Typical water flow rates @ 77°F (25°C) for 10 inch Cartridges and J Style Capsules

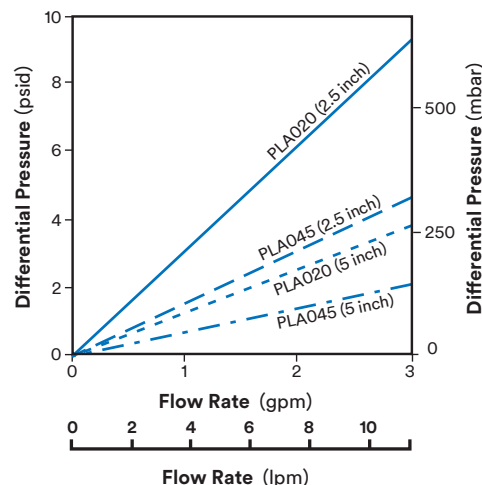

Chart 4. Typical water flow rates @ 77°F (25°C) for Mini-Cartridges and Sanitary Style Capsules with .20 & .45 µm media**

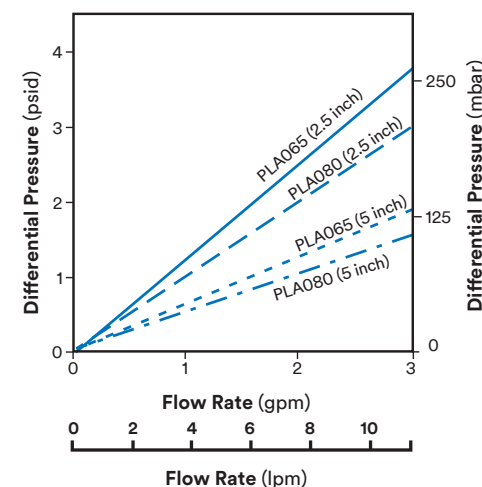

Chart 5. Typical water flow rates @ 77°F (25°C) for Mini-Cartridges and Sanitary Style Capsules with 0.65 & 0.80 µm media**

* Millipore Milligard mini-cartridges are 4" long, all others are 5".

** For capsules with Hose Barb Fittings, add .36 psi @ 2 gpm

Filters for Pharmaceutical and Biological Service

The table below provides a guide to 3M™ LifeASSURE™ PLA series prefilter selection, although actual process conditions may dictate the use of a more open or tighter prefilter, than specified below. Pre-filter selection can be aided by smaller scale pilot tests or flow decay studies using membrane discs or 3M LifeASSURE PLA series Capsules. Consult 3M Scientific Applications Support Services (SASS) or your 3M Sales Specialist for more information.

| Grade | Upstream Zone | Downstream Zone | Pre-filter for: |
|--------|---------------|-----------------|--|
| PLA020 | 0.65 micron | 0.20 micron | 3M™ LifeASSURE™ SA020SP Series, 3M™ LifeASSURE™ PSA010 Series |
| PLA045 | 0.8 micron | 0.45 micron | 3M™ LifeASSURE™ SA020SP Series, 3M™ LifeASSURE™ PSA010, PSA020 Series |
| PLA065 | 1.2 micron | 0.65 micron | 3M™ LifeASSURE™ PSA010 Series |
| PLA080 | 2.5 micron | 0.80 micron | 3M™ LifeASSURE™ PSA010 Series |

3M™ LifeASSURE™ PLA series Cartridge Construction

3M LifeASSURE PLA series filters are constructed of single-layer, Nylon 6,6 microporous membrane pleated with polypropylene upstream and downstream support materials. The outer cage, inner core, end-cap adapters and capsule shell are made of polypropylene. All materials of construction are CFR 21 listed and have passed USP Class VI Biological Tests for Plastics at 121°C. Filters are manufactured under an ISO 9001:2008 certified quality system using the most advanced thermoplastic welding techniques to ensure filter integrity. 3M LifeASSURE PLA series filters are 100% integrity tested after manufacture to ensure quality and are supplied with a Certificate of Quality. A regulatory support file (RSF) is available to assist in regulatory control and documentation (request 70-0201-8821-8).

3M™ LifeASSURE™ PLA Series Filter Specifications

| Material of Construction | Cartridges | | | | | Mini-Cartridges | | | | Capsules | | |
|---|---|---------------|---------------|---------------|---------------|-----------------|----------------------------------|----------------------------|--------------|---------------|---------------|---------------|
| | 5" | 10" | 20" | 30" | 40" | 2.5" | 5" | 2.5" | 5" | 10" | 20" | 30" |
| Outer Cage, Inner Core, End-Cap Adapters, Capsule Shell, and Media Support Layers | Polypropylene | | | | | | | | | | | |
| Membrane | Multi-zone microporous membrane Nylon 6,6 | | | | | | | | | | | |
| Adapter Support Ring (full length cartridges only) | 316 Stainless Steel | | | | | NA | | | | | | |
| Dimensions | 5" | 10" | 20" | 30" | 40" | 2.5" | 5" | 2.5" | 5" | 10" | 20" | 20" |
| Filtration Surface Area ft ² (m ²) | 5.1 (0.47) | 11.4 (1.1) | 22.8 (2.1) | 34.2 (3.2) | 45.6 (4.2) | 2.0 (0.2) | 3.4 (0.3) | 2.0 (0.2) | 3.4 (0.3) | 11.4 (1.1) | 22.8 (2.1) | 34.2 (3.2) |
| Outside Diameter — inch (cm) | 2¾ (7 nominal) | | | | | 2¾ (5.7) | 2¾ (5.7) | 3⅞ (7.9) | | | | |
| Length — Nominal inches (Nominal cm) | 5, 10, 20, 30, and 40 (13, 25, 50, 75, and 100) | | | | | 3⅞ (7.9) | 5½ (14.0) | 1.5" Sanitary Inlet/Outlet | | | | |
| | | | | | | | | 5⅞ (13.0) | 7⅞ (19.4) | 12¾ (30.9) | 22⅞ (56) | 32 (81.3) |
| | | | | | | | | ½" Hose Barb Inlet/Outlet | | | | |
| | | | | | | 5½ (14.0) | 8 (20.3) | NA | NA | NA | NA | NA |
| Operating Parameters | | | | | | | | | | | | |
| Maximum Operation Temp. | 176°F (80°C) | | | | | | 104°F (40°C) | | | | | |
| Maximum Differential Pressure | Forward: 80 psid (5.5 bar) @ 77°F (25°C) 25 psid (1.7 bar) @ 176°F (80°C) | | | | | | 75 psid (5.2 bar) @ 104°F (40°C) | | | | | |
| | Reverse: 50 psid (3.4bar) @ 77°F (25°C) | | | | | | | | | | | |
| Steam Sterilization | 30 minutes @ 259°F (126°C) | | | | | | Do Not <i>in situ</i> steam | | | | | |
| Autoclave Sterilization | | | | | | | 30 minutes @ 259°F (126°C) | | | | | |
| Installation Integrity Test Methods | Consult 3M for appropriate values for the specific filter and housing in use. | | | | | | | | | | | |

Mini-Cartridges

3M 2.5" and 5" mini-cartridges can be installed in Pall Sealkleen® housings or the 3M Mini-Cartridge housing, document 70-0201-8886-1. The significant 3M™ LifeASSURE™ PLA series filters' flow advantage (Charts 4 and 5) results in greater batch capacity than competitive filters, greatly reducing filter costs.

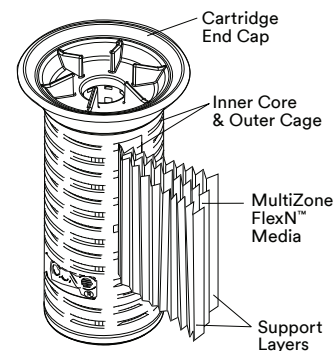

Mini-Cartridge

Disposable Filter Capsules

For critical small-volume applications where convenience and ease of use are desired, 3M LifeASSURE PLA series filters are available in 2.5, 5, 10, 20, and 30" disposable capsules. 3M LifeASSURE PLA series capsules are supplied with sanitary vent and drain ports, as well as a choice of 1.5" sanitary flange connections or ½" (13 mm) hose barb inlet/outlet connections (2.5 and 5" only).

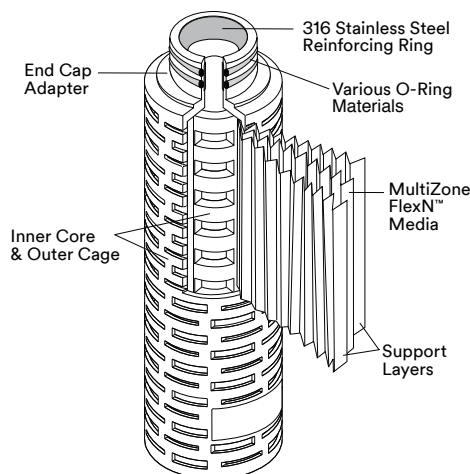

Standard Cartridge

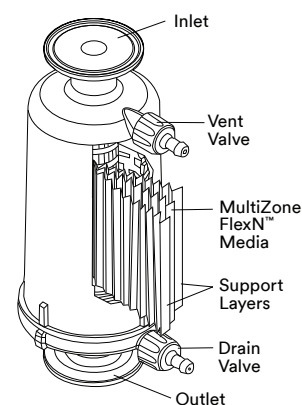

Capsule

Safety and Regulatory Compliance

Installation Integrity Test

Unlike other prefilters, 3M LifeASSURE PLA series filters are 100% tested for integrity in manufacturing prior to shipment. Additionally, 3M LifeASSURE PLA series filter cartridges are installation integrity testable *in situ* by the user. The installation integrity test is a non-destructive measurement of a filter's ability to function as intended. Conducting an installation integrity test assures the user that the filter is installed and sealed correctly in the filter housing and is ready for service. This is of particular value where 3M LifeASSURE PLA series filters are employed in intermediate process steps not requiring a sterilizing grade final membrane filter.

For installation integrity test procedures and values, please consult document 70-0202-2027-6.

3M™ 200 Automated Integrity Test Device

The installation integrity test can also be performed with the 3M™ 200 Automated Integrity Test device. The 3M 200 Automated Integrity Tester provides fast, reliable and accurate automated installation integrity testing of 3M LifeASSURE PLA series filters, capsules and mini-cartridges. For more information, see document 70-0201-8692-3.



3M Final Filters

3M LifeASSURE PSA series Filters - Employed as the final filter in critical applications, 3M LifeASSURE PSA series filter and capsules are constructed with multi-zone microporous membrane nylon 6,6 membrane and polypropylene components (see document 70-0201-8893-7). 3M LifeASSURE PSA series sterilizing grade filters are qualified for complete retention (>10⁷ CFU/cm²) of *B. diminuta* following ASTM methodology. 3M LifeASSURE PSA series filters are supported with a 3M Validation Guide, document 70-0201-8848-1.



Validation Support Services

3M offers specialized support to the pharmaceutical and biotechnology industry through our Scientific Application Support Services (SASS) Group. SASS routinely provides end-users with:

- Validation And Regulatory Support
- Extractable And Compatibility Analysis
- Filter System Optimization Studies
- CUNOCheck™ 2 Integrity Test Instrument Training

For more information regarding 3M's Validation Support Services, please contact 3M Technical Services.



Filter Housings

A specialized range of filter housings are available to meet the needs of the pharmaceutical, biological, and bioprocess industries. They provide easy access for filter change-out and the greatest assurance that 3M™ LifeASSURE™ PLA series filters are sealed securely, thus eliminating the possibility of fluid bypass. All housings are constructed using 316L stainless steel to maximize corrosion resistance. Internal surfaces of the housings are polished to limit microbial adhesion and provide easy cleaning.

| Housing Model | ZMS Mini | ZMS | ZWC | ZWB | ZVS | Mini-Housing | |
|--|----------------------------------|--|---------------------------------|----------------------------------|----------------------------------|-----------------------------|---------------------------|
| | For 5 inch Cartridge | For 10, 20, 30, and 40 inch Cartridges | | | | For 2.5 inch Mini-Cartridge | For 5 inch Mini-Cartridge |
| Basic Part Number/ Cartridge Capacity | 70236-02 / 1 | 70220 / 1 | 70180/4 | 70269-4 | 70221/1 | 70235-02/1 | 70235-01/1 |
| | | | 70189/8 | 70270-8 | | | |
| | | | 70190/11 | 70271-11 | | | |
| | | | 70191/21 | 70272-21 | | | |
| Housing Style | T-line Sanitary type connection | | | Sanitary type in-line | | | |
| Equivalent Cartridge Lengths | 5 inches | 10, 20, 30, and 40 inches | | | | 2.5 inches | 5 inches |
| Materials of Construction | 316L Stainless Steel | | | | | | |
| Pressure and Temperature Ratings | 150 psi (10 bar) @ 300°F (149°C) | *75 psi (5 bar) @ 200°F (90°C) | 150 psi (10 bar) @ 200°F (90°C) | 150 psi (10 bar) @ 300°F (149°C) | 150 psi (10 bar) @ 300°F (149°C) | | |
| Document # | 70-0201-8887-9 | 70-0201-8883-8 | 70-0201-8884-6 | | 70-0201-8883-8 | 70-0201-8886-1 | |

* 21ZWC rated at 68 psi



3M offering of sanitary style filter housings accommodate from 1 to 21 3M™ LifeASSURE™ PLA series filters in 10" through 40" lengths.



3M Mini-Cartridge filter housings provide the user with low product hold-up volume for critical small scale applications.

3M™ LifeASSURE™ PLA Series Cartridge Ordering Guide

| Grade Designation | Configuration | Length (Inches) | End Modification | Gasket/O-Ring Material |
|--|---------------------------|---|--|--|
| PLA020 - 0.20 micron PLA045 - 0.45 micron PLA065 - 0.65 micron PLA080 - 0.80 micron | B - Pleated Configuration | 01 - 10 02 - 20 03 - 30 04 - 40 50 - 5* | B - 226 O-ring & Spear (Code 7) C - 222 O-ring & Spear (Code 8) D - Double open end (10 inch Length) E - Double open end (9 inch Length) F - 222 O-ring & Flat Cap (Code 3) J - 226 O-ring & Flat Cap | A - Silicone B - Fluorocarbon C - EPR D - Nitrile |

* Not Available with D or E end-modification.

3M™ LifeASSURE™ PLA Mini-Cartridge Ordering Guide

| Grade Designation | Configuration | Length (Inches) | End Modification | Package Quantity |
|--|--------------------|----------------------|------------------|-------------------|
| PLA020 - 0.20 micron PLA045 - 0.45 micron PLA065 - 0.65 micron PLA080 - 0.80 micron | M - Mini-Cartridge | 01 - 2.5 02 - 5.0 | A - Standard | 06 - 6 Cartridges |

3M™ LifeASSURE™ PLA 2.5" and 5" Capsule Ordering Guide

| Grade Designation | Configuration | Length (Inches) | End Modification | Package Quantity |
|--|---------------|--------------------|---------------------------------------|---------------------|
| PLA020 - 0.20 micron PLA045 - 0.45 micron PLA065 - 0.65 micron PLA080 - 0.80 micron | C - Capsules | 01 - 2.5 02 - 5 | A - Sanitary Fitting B - Hose Barb | 01 - Single Capsule |

3M™ LifeASSURE™ PLA 10", 20", and 30" Capsule Ordering Guide

| Grade Designation | Configuration | Nominal Length (Inches) | End Modification | Gasket/O-Ring Material | Package Quantity |
|--|---------------|-------------------------------|---------------------|---|---------------------|
| PLA020 - 0.20 micron PLA045 - 0.45 micron PLA065 - 0.65 micron PLA080 - 0.80 micron | J - Capsule | 01 - 10 02 - 20 03 - 30 | A - Sanitary Flange | A - Silicone B - Fluorocarbon C - EPR | 01 - Single Capsule |

Filters for Pharmaceutical and Biological Service

PLEASE NOTE: The Ordering Guide above is for reference only. Not all combinations are available. Please consult with your 3M Representative to determine the appropriate part number for your application.

| Technical Information |
|---|
| The technical information, guidance, and other statements contained in this document or otherwise provided by 3M are based upon records, tests, or experience that 3M believes to be reliable, but the accuracy, completeness, and representative nature of such information is not guaranteed. Such information is intended for people with knowledge and technical skills sufficient to assess and apply their own informed judgment to the information. No license under any 3M or third party intellectual property rights is granted or implied with this information. |
| Product Selection and Use |
| Many factors beyond 3M's control and uniquely within user's knowledge and control can affect the use and performance of a 3M product in a particular application. As a result, customer is solely responsible for evaluating the product and determining whether it is appropriate and suitable for customer's application, including conducting a workplace hazard assessment and reviewing all applicable regulations and standards (e.g., OSHA, ANSI, etc.). Failure to properly evaluate, select, and use a 3M product and appropriate safety products, or to meet all applicable safety regulations, may result in injury, sickness, death, and/or harm to property. |
| Warranty, Limited Remedy, and Disclaimer |
| Unless a different warranty is specifically stated on the applicable 3M product packaging or product literature (in which case such warranty governs), 3M warrants that each 3M product meets the applicable 3M product specification at the time 3M ships the product. 3M MAKES NO OTHER WARRANTIES OR CONDITIONS, EXPRESS OR IMPLIED, INCLUDING, BUT NOT LIMITED TO, ANY IMPLIED WARRANTY OR CONDITION OF MERCHANTABILITY, FITNESS FOR A PARTICULAR PURPOSE, OR ARISING OUT OF A COURSE OF DEALING, CUSTOM, OR USAGE OF TRADE. If a 3M product does not conform to this warranty, then the sole and exclusive remedy is, at 3M's option, replacement of the 3M product or refund of the purchase price. |
| Limitation of Liability |
| Except for the limited remedy stated above, and except to the extent prohibited by law, 3M will not be liable for any loss or damage arising from or related to the 3M product, whether direct, indirect, special, incidental, or consequential (including, but not limited to, lost profits or business opportunity), regardless of the legal or equitable theory asserted, including, but not limited to, warranty, contract, negligence, or strict liability. |



3M Purification Inc.
3M Separation and Purification Sciences Division
400 Research Parkway
Meriden, CT 06450 USA

Phone 1-800-243-6894
1-203-237-5541
Fax 1-203-630-4530
Web 3Mpurification.com

3M, CunoCheck, and LifeASSURE are trademarks of 3M Company. All other trademarks are the property of their respective owners
© 2011 3M Company. All rights reserved.
70-0201-8713-7 REV 1211 AO