

Aqua-Pure®

Models:

CS-S / LC / Complete

Drinking Water Systems

Applications:

- Chlorine Taste & Odor
- Particulate*
- Lead
- Parasitic Protozoan Cysts
- Select VOCs**

At a Glance:

- Easy to select the right product
- Easy to install, no special tools required
- Easy to maintain, filter change is a twist



Complete

CS-S

LC

Product Benefits:

- All systems reduce Chlorine Taste & Odor and Particulate* helping provide better tasting water and cleaner ice cubes for your refrigerator
- LC also reduces Lead and Parasitic Protozoan Cysts
- Complete also reduces Lead, Parasitic Protozoan Cysts, Mercury, Turbidity, Asbestos and Select VOCs**
- Designed with built-in bypass valve — no need to shut off water for cartridge change
- Everything included for most installations

*Tested and verified by manufacturer's laboratory

**Select VOCs include: Lindane, Atrazine, Benzene, Carbofuran, P-dichlorobenzene and Toxaphene

Product Specifications:

Model No. (Part No.)	Inlet/ Outlet Size	Dimensions		Flow Rate	Capacity	Max. Water Temp.	Max. Water Pressure	Std. Replacement Ctg. No.
		Height	Diameter					
CS-S (56179-05)	1/4" Push	10-1/2" (26.7 cm)	2-3/8" (6.0 cm)	0.75 gpm (2.8 lpm)	750 gallons (2,839 liters)	100°F (37.8°C)	120 psi (827 kPa)	C-CS-S (56180-09)
LC (56179-06)								C-LC (56180-11)
Complete (56179-04)		12-1/2" (31.8 cm)	C-Complete (56180-07)					

Aqua-Pure®

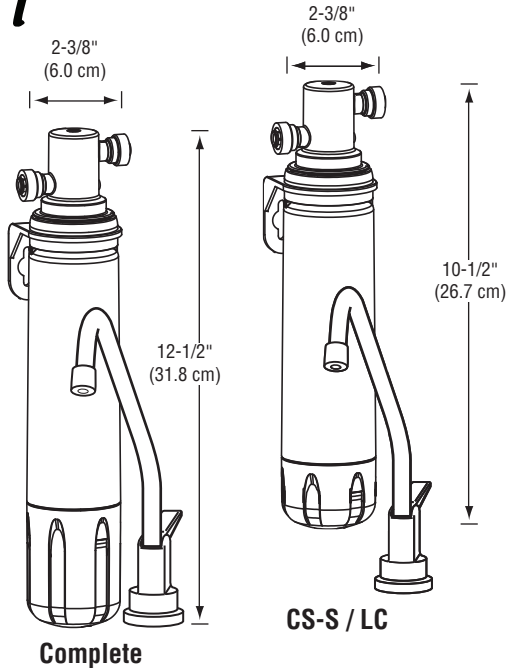

Spec #

Quantity

Model Number

Part Number

Easy Installation:

CAUTION: Diagram shown is for reference purposes only. Read installation and operation manual prior to installing the unit.

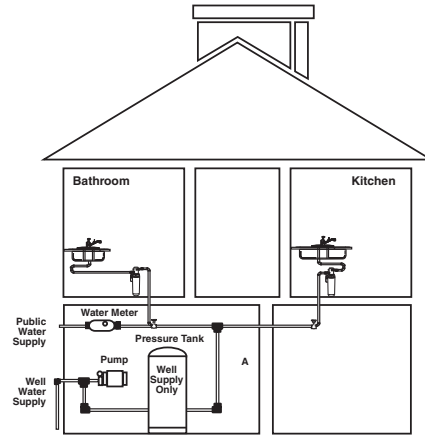

Physical Specifications:

- 1/4" Quick Connect fittings
- System is a single vessel design
- System is manufactured from FDA CFR-21 compliant materials
- System has a maximum operating pressure of 120 psi (827 kPa) and operating temperature of 100°F (37.8°C)
- System includes attached mounting bracket
- System includes dedicated faucet
- System to be installed on primary kitchen or bath cold water line

⚠ WARNING

To reduce the risk associated with ingestion of contaminants:

- **Do not use with water that is microbiologically unsafe or of unknown quality without adequate disinfection before or after the system.** Systems certified for cyst reduction may be used on disinfected water that may contain filterable cysts. EPA Establishment #070595-CT-001

CAUTION

To reduce the risk associated with property damage due to water leakage:

- **Read and follow** Use Instructions before installation and use of this system.
- The disposable filter cartridge **MUST** be replaced every six (6) months, at the rated capacity or sooner if a noticeable reduction in flow rate occurs.

Limited Warranty:

3M Purification Inc. warrants this Product will be free from defects in material and manufacture for one (1) years from the date of purchase: The filter cartridge or filter membrane is warranted to be free from defects in material and manufacture for one (1) year. This warranty does not cover failures resulting from abuse, misuse, alteration or damage not caused by 3M Purification Inc. or failure to follow installation and use instructions. No warranty is given as to the service life of any filter cartridge or membrane as it will vary with local water conditions and water consumption. **3M PURIFICATION INC. MAKES NO OTHER WARRANTIES OR CONDITIONS, EXPRESS OR IMPLIED, INCLUDING, BUT NOT LIMITED TO, ANY IMPLIED WARRANTY OR CONDITION OF MERCHANTABILITY OR FITNESS FOR A PARTICULAR PURPOSE OR ANY IMPLIED WARRANTY OR CONDITION ARISING OUT OF A COURSE OF DEALING, CUSTOMER OR USAGE OF TRADE.** If the Product fails to satisfy this Limited Warranty during the warranty period, 3M Purification Inc. will replace the Product or refund your Product purchase price. This warranty does not cover labor. **The remedy stated in this paragraph is Customer's sole remedy and 3M Purification Inc.'s exclusive obligation. For additional information, see the entire Limited Warranty located in the product Installation and Operating Instruction Manual.**

3M

3M Purification Inc.
400 Research Parkway
Meriden, CT 06450, U.S.A.
Tel (800) 222-7880
(203) 237-5541
Fax (203) 238-8701
www.aquapure.com
www.3mpurification.com



Visit www.nsf.org for the claims associated with products that are NSF listed.

Distributed by:

Please recycle. Printed in U.S.A.
3M is a trademark of 3M Company.
Aqua-Pure is a trademark of 3M Company used under license.
NSF is a trademark of NSF International.
© 2011 3M Company. All rights reserved.
70-0201-9313-5 REV 1210