

3M

Aqua-Pure[™]

Installation and Operating Instructions For

3MFF100

Full Flow Drinking Water System

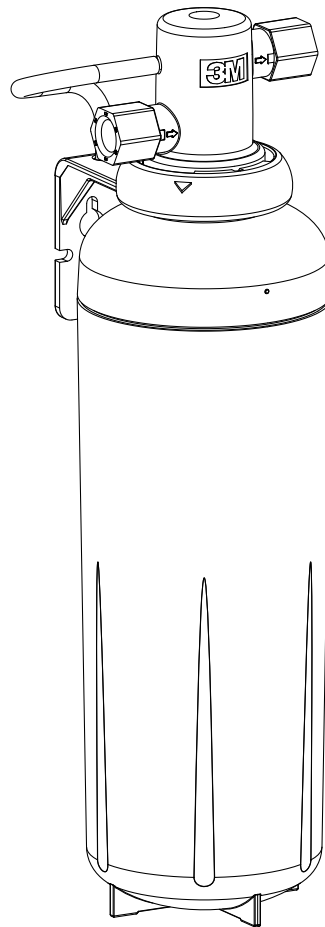

System tested and Certified by NSF International against NSF/ANSI Standard 42 and 53 and CSA B483.1 for the reduction of the claims specified on the Performance Data Sheet.



This product is certified by the Water Quality Association to WQA S-803 for Sustainability Attributes.

Installer: Please leave manual with homeowner.
Homeowner: Please retain for operation and future maintenance instructions.

SAFETY INFORMATION

Read, understand, and follow all safety information contained in these instructions prior to installation and use of this 3M™ Aqua-Pure™ Full Flow Drinking Water System Model 3MFF100. Retain these instructions for future reference.

Intended use:

The 3M Brand 3MFF100 Drinking Water System filters drinking water at your faucet tap, also known as a point-of-use system. The systems are designed to be installed under a sink connected to a drinking faucet cold water supply line, plumbed-in to a drinking water fountain, plumbed into a home or office ice machine, or plumbed into a home or office coffee machine. This product should be connected to a public or private drinking water supply system.

The 3M Brand 3MFF100 Drinking Water System has been tested and certified to NSF/ANSI standard 42, 53, and CSA B483.1 for the reduction of the substances listed in the system Performance Data Sheet. The system does not reduce all substances that could be present in your water. Verify this system meets your water treatment needs by checking your incoming water quality before installation and comparing to the system's capabilities stated in the Performance Data Sheet.

The 3M Brand 3MFF100 Drinking Water System must be installed and maintained as specified in the installation instructions and in compliance with applicable local plumbing codes and regulations. It is recommended the system be installed by a qualified professional.

Explanation of Signal Word Consequences	
 WARNING:	Indicates a hazardous situation which, if not avoided, could result in serious injury or death.
NOTICE:	Indicates a situation which, if not avoided, could result in property damage.

 WARNING:
<p>Read entire product manual. Failure to follow all product instructions and warnings could cause personal injury from exposure to contaminants and/or property damage due to water leakage or flooding.</p> <ul style="list-style-type: none">• DO NOT use with water that is microbiologically unsafe or of unknown quality without adequate disinfection before or after the system. Systems certified for cyst reduction may be used on disinfected water that may contain filterable cysts.• THIS SYSTEM DOES NOT REMOVE ALL SUBSTANCES THAT COULD BE PRESENT IN DRINKING WATER. This system reduces the listed substances identified in the Performance Data Sheet.• VERIFY THIS SYSTEM meets your water treatment needs by checking your incoming water source quality and comparing to the system's capabilities described in the Performance Data Sheet. Check water source quality by contacting your local water authority and/ or having water tested by a qualified laboratory. Check water quality regularly as it can change. After installation, test outgoing filtered water quality regularly to ensure system is installed correctly and meeting your treatment needs, especially if your filter's incoming water or plumbing system may have high contaminant levels. Actual performance may vary depending on your local water and plumbing conditions and water consumption patterns.• DO NOT use product if it has been hit, dropped, or damaged.• Before using, flush any new filter cartridge with water according to the Performance Data Sheet. In addition, flush the cartridge whenever the system has not been used for more than 72 hours.• REPLACE FILTER CARTRIDGE no later than every 6 or 12 months. If the rated gallon capacity is reached or a noticeable reduction in flow rate, change in odor or taste occurs before 6 or 12 months of use, then replace filter promptly. Failure to replace filter cartridge according to these instructions may result in failure of filter to reduce contaminants as designed AND/OR property damage due to water leakage or flooding. <p>To reduce the risk associated with choking:</p> <ul style="list-style-type: none">• DO NOT allow children under 3 years of age to access small parts.

NOTICE:

Read entire product manual. Failure to follow all product instructions may lead to property damage due to water leakage or flooding. Contact a licensed plumber if you are unsure about any of the following instructions:

- System installation and use must comply with all state and local regulations and plumbing codes.
- Water Supply Pressure: If your water supply pressure is higher than 80 psi, you must install a pressure reducing valve before installing system.
- Water Hammer: if water hammer conditions may occur, you must install a water hammer arrester.
- Backflow prevention: If a backflow prevention device is installed on a water system, you must install a device for controlling pressure due to thermal expansion.
- Booster Pump: if a booster pump is installed on a water system, you must (a) maintain and inspect the attached pressure switch regularly in accordance with the booster pump manufacturer's instructions; and (b) install an appropriate pressure reducing valve, and maintain and inspect the valve regularly.
- When mounting the system, pick a location where (a) the filter will not be struck by other items, (b) no equipment, electrical wires or pipes will be in the path of your drilling or tools, and (c) the fasteners will support the weight of the system when full of water.
- Install only on cold water supply line. **DO NOT** install where ambient temperatures or water temperatures may exceed 100°F (37.8°C). **DO NOT** install in direct sunlight or outdoors.
- Protect from freezing. Remove filter cartridge if temperature may drop below 40°F (4.4°C).
- **DO NOT** install with rigid piping (such as copper, aluminum, stainless steel, chrome plated, or anodized tubing).
- Use compatible flexible tubing with appropriate connections (such as PEX tubing, PE tubing, PP tubing). Avoid twisting during installation.
- **DO NOT** install or use if a collet or any other component is missing. Contact 1-866-990-9785 or your local distributor.
- **DO NOT** use product if it has been hit, dropped, or damaged.
- **REPLACE FILTER CARTRIDGE** no later than every 6 or 12 months or sooner. Failure to replace the filter cartridge at the required time may lead to property damage due to water leakage or flooding.
- Inspect on a regular basis to ensure system is performing appropriately, filter cartridges are replaced in a timely manner, and all tubing and fittings are secure and free of leaks.

For Performance Data Sheet go to 3M.com/waterquality or contact 3M at 1-866-990-9785. For additional product information, including product manual and spec sheets, contact 3M at 1-866-990-9785.

For additional information on cartridge replacements please go to 3M.com/waterquality.

IMPORTANT NOTES:

- Failure to follow instructions will void warranty.
- Allow a minimum of 3" (7.62 cm) clear space under filter to facilitate filter change.

PRODUCT SPECIFICATIONS

Flow Rate: 2.5 gpm (9.5 lpm)

Pressure: 30 - 125 psi (172 - 862 kPa)

Temperature 40 - 100°F (4.4 - 37.8°C)

Capacity: 6,000 gallons (22,712 liters)

GETTING STARTED

- Installation requires some household tools and additional plumbing components.

Parts and Materials Required for 3MFF100 Undersink Installation (Included):

1. Filter Head Assembly
2. Filter

Items Required (not included):

- Adjustable wrench
- Cordless drill
- Phillips head screwdriver
- Razor knife or tube cutter
- PTFE Tape
- Additional installation parts will be required (3/8" NPT fitting and tubing)

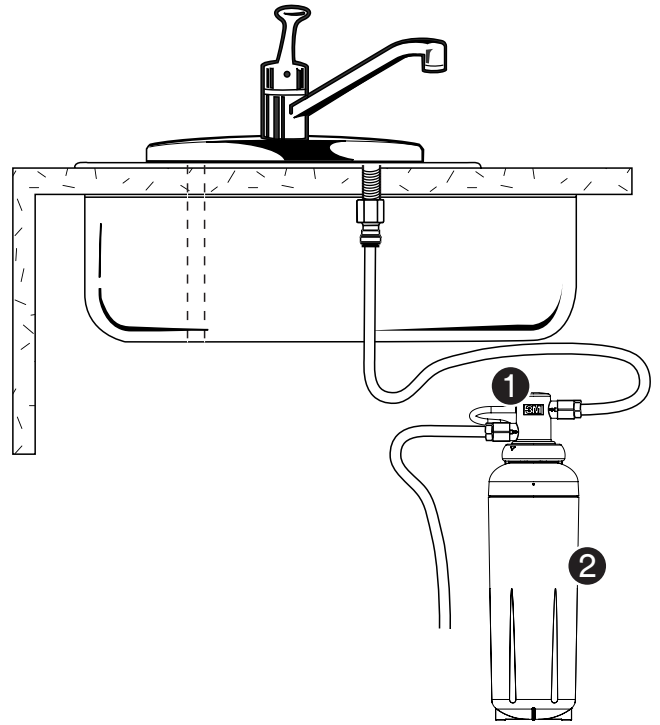

Figure 1

IMPORTANT INSTALLATION INSTRUCTIONS

The following installation instructions described are based on copper plumbing with 3/8" compression fittings. Additional fittings may be required to connect to cold water supply.

1. Open faucet and turn off cold water supply to relieve pressure.
2. Select and mark a location under the sink that allows access for filter change. You will be connecting to the existing line with 3/8" tubing and various fittings not supplied with this filter assembly.
3. Using filter head assembly as a guide, fasten filter head assembly to wall with fasteners. (See Figure 2)

Allow 3" clearance from bottom of replacement filter for ease of removal.

4. Place a basin or a towel under the cold water supply valve. Remove the cold side riser tubing between your cold water supply valve to your primary faucet connection.
5. Install faucet adapter fitting (not included) to faucet stem. This should be a snug fit. Do not overtighten. (See Figure 3) Ensure the black gasket is inserted into the faucet adapter prior to assembly.
6. Install 3/8 NPT Fittings (Not Included) into filter head using PTFE Tape. Do not overtighten.

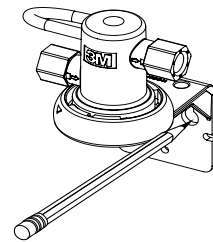
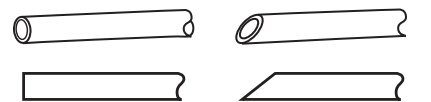

Figure 2



Figure 3



Correct Incorrect

Figure 4

7. Determine length of 3/8" tubing (not included) required from filter head outlet to faucet adapter by holding tubing in place ensuring it is of appropriate length. Do not kink tubing as this will impede water flow. If necessary, loop tubing around to avoid it being kinked. Cut tubing straight with a razor knife. (See Figure 4)
8. Insert 3/8" tubing from faucet adapter fitting into the filter OUTLET fitting as shown in Figure 5.
9. Determine length of 3/8" tubing (not included) required from filter head inlet to cold water supply valve by holding tubing in place ensuring it is of appropriate length. Do not kink tubing as this will impede water flow. If necessary, loop tubing around to avoid it being kinked. Cut tubing straight with a razor knife. (See Figure 4)
10. Using a tube ferrule, compression nut and tube support (not included), slide nut and ferrule over 3/8" tubing, insert tube support and connect to the cold water supply valve. (See Figure 5) Insert other end into filter INLET fitting as shown in Figure 1.
11. Remove sanitary protective cap from filter. Ensure both o-rings are present on the filter and are seated into grooves; moisten o-rings with water. DO NOT use any petroleum products to lubricate the o-rings.

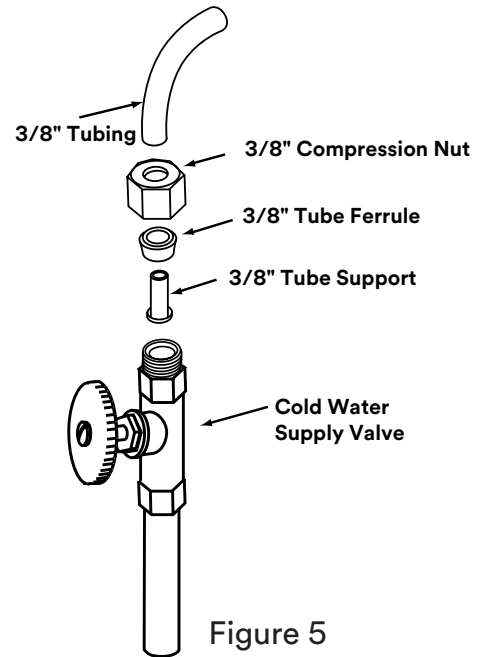

Note: White tube from head is a filter vent tube outlet. DO NOT remove, kink or obstruct white tube.

IMPORTANT NOTES:

- Allow a minimum of 3" (7.6 cm) clear space under the system to facilitate filter changes.
- All components should be accessible and have a sufficient amount of clearance on all sides of the system to facilitate servicing.

12. Align lugs of filter with head assembly and insert filter into head assembly. Turn filter to the right (clockwise) until it stops (about 1/4 turn). The filter is now installed. (See Figure 6)
13. Turn on cold water supply valve and open faucet to flush air from the system. Run water for a minimum of 5 gallons (approximately 2 minutes) to flush system.
14. Close the faucet. The system is now ready for use. System is now under pressure and can be inspected for leaks. Repair any leaks as needed before continuing.

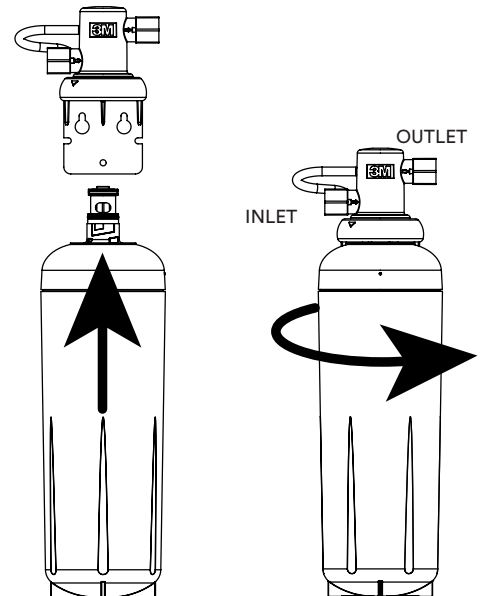

Figure 6

FILTER REPLACEMENT INSTRUCTIONS

NOTICE:

To reduce the risk associated with property damage due to water leakage or flooding:

- Change the disposable filter cartridge at the recommended interval; the disposable filter cartridge MUST be replaced every 12 months or sooner

1. Place towel under filter to collect any residual water during replacement filter change-out.
2. Grasp filter and turn to the left (counterclockwise) until filter comes to a complete stop (water automatically turns off). Water may leak momentarily from vent tube. This is normal. Gently pull filter downward to remove.
3. Remove sanitary protective cap from new replacement filter.
4. Ensure both o-rings are present on the replacement filter and are seated into grooves; moisten o-rings with water. DO NOT use any petroleum products to lubricate the o-rings.
5. Insert replacement filter into filter head assembly. Turn replacement filter one quarter turn to the right (clockwise) until it stops. When fully engaged, the top surface of the filter will be flush with the bottom of the filter head assembly. (See Figure 6)
6. Open faucet and run water for a minimum of 5 gallons (approximately 2 minutes). While system is flushing, check for leaks. Repair any leaks as needed before continuing.
7. Close filter system faucet. System is now under pressure and can be inspected for leaks. Repair any leaks as needed before continuing. The system is now ready for use.

TROUBLESHOOTING GUIDE

Water Leaks at Push-In Connections:

Push tubing in as far as it will go. If leaking continues, shut off water at the cold water supply valve and remove water line by pushing in on the connector collar while pulling the tubing away. Inspect tubing for cracks and scratches. If tubing is cracked or scratched, simply cut that portion away and reinsert tubing into push-in fitting.

Make sure tubing is cut straight. If not, recut correctly. Please refer to Figure 4.

If water leaks, please verify that the o-rings are properly seated in their grooves.

Water Does Not Flow From The Faucet:

Check to see if the main water line valve is open, allowing water to flow to the filter. Make sure the connections are not reversed.

Water Appears Cloudy or Air Comes Out of the Faucet:

Flush 5 gallons through system before use (approximately 2 minutes).

Product Selection and Use: Many factors can affect whether a 3M product is appropriate for a particular application and how it performs, including local water and plumbing conditions. Customer is solely responsible for determining whether a 3M product meets customer's specific application requirements, including testing incoming source water quality and comparing it to the product's capabilities described in the Performance Data Sheet. Failure to properly evaluate, select, use or maintain a 3M product, or to meet applicable regulations or instructions, may result in personal injury from exposure to contaminants AND/OR property damage due to water leakage or flooding.

Limited Warranty, Limited Remedy, and Disclaimer: 3M warrants that this product (excluding filter cartridge or filter membrane) will be free from defects in material and manufacture for the period of one (1) year from the date of purchase. No warranty is given as to the service life of any filter cartridge or membrane as it will vary with local water conditions and water consumption. Except as required by law, 3M MAKES NO OTHER WARRANTIES OR CONDITIONS, EXPRESS OR IMPLIED, INCLUDING, BUT NOT LIMITED TO, ANY IMPLIED WARRANTY OR CONDITION OF MERCHANTABILITY OR FITNESS FOR A PARTICULAR PURPOSE OR ANY IMPLIED WARRANTY OR CONDITION ARISING OUT OF A COURSE OF DEALING, CUSTOM OR USAGE OF TRADE. This warranty does not cover failures resulting from misuse, alterations, failure to follow instructions or damage not caused by 3M. This warranty does not cover labor. If the 3M product does not conform to this warranty, then the sole and exclusive remedy is, at 3M's option, replacement of the 3M product or refund of the purchase price.

This warranty gives you specific legal rights, and you may have other rights which may vary from state to state, or country to country. For warranty questions or service, please call 866.990.9785. Proof of purchase must accompany a warranty claim.

Limitation of Liability: Except for the limited remedy stated above, and except to the extent prohibited by law, 3M will not be liable for any loss or damage arising from or related to the 3M product, whether direct, indirect, special, incidental, or consequential (including, but not limited to, lost profits or business opportunity), regardless of the legal or equitable theory asserted, including, but not limited to, warranty, contract, negligence, or strict liability.



**3M Purification Inc.
3M Separation and
Purification Sciences Division**

400 Research Parkway
Meriden, CT 06540

Phone 1-866-990-9785
WW 1-203-237-5541
Web 3M.com/waterquality

3M is a trademark of 3M Company.
NSF is a trademark of NSF International.
WQA is a trademark of Water Quality Association.
Please recycle. Printed in USA.
© 2022 3M Company. All rights reserved.
34-8728-2727-3