

3M™ Advanced Drinking Water Filtration System 3MDW301

Applications:

- Under Sink (available with and without faucet)
- Provides cleaner, better tasting water by reducing a comprehensive set of contaminants

At a Glance:

- NSF Standard 42, 53, 372 and 401 certified
- Easy to install, no special tools required
- Easy to maintain, filter change is a twist, no mess
- Built-in mounting bracket

Product Benefits:

- Advanced multi-stage filtration with membrane and carbon block media to help provide cleaner, clearer, better tasting drinking water
- NSF 42 certified to reduce class 1 particulate (0.5 – 1.0 microns), chlorine, taste and odor, and chloramine
- NSF 53 certified to reduce asbestos, parasitic protozoan cysts (cryptosporidium), lead, methyl tert-butyl ether (MTBE), trihalomethanes (TTHM), volatile organic compounds (VOCs), and 1,2,3-trichloropropane (1,2,3-TCP)
- NSF 401 certified to reduce emerging compounds such as pharmaceuticals and personal care products (PPCPs) and endocrine disrupting compounds (EDCs) including microplastics, bisphenol A (BPA), diethyltoluamide (DEET), ibuprofen, atenolol, estrone, carbamazepine, linuron, metolachlor, meprobamate, naproxen, nonylphenol, phenytoin, and trimethoprim
- Sanitary Quick-Change (SQC) cartridge helps provide fast and easy water filter cartridge change-outs
- Built-in shut-off valve eliminates the need to shut off water while changing water filter cartridges
- Filter capacity of 1,000-gallons (3,785-liter) can provide quality water to meet high demand at 0.75 gallons per minute (2.84-lpm)



3M™ DW301-01

3M™ DW301-F

Product Specifications

Model No. (Part No.)	3M ID	Inlet/Outlet Size	Height	Diameter	Flow Rate	Capacity	Max. Water Temp.	Max. Water Pressure	Std. Replacement Ctg. No.
3MDW301-01	70-0202-4184-3	1/4" Push (0.635 cm)	16-3/8" (41.3 cm)	4-15/16" (11.3 cm)	0.75 gpm (2.8 lpm)	1,000 gallons	100° F (37.8° C)	125 psi (862 kPa)	3MDW311-01
3MDW301-F	70-0203-6659-0	3/8" NPT (1.27 cm)	16-3/8" (41.3 cm)	4-15/16" (11.3 cm)	0.75 gpm (2.8 lpm)	1,000 gallons	100° F (37.8° C)	125 psi (862 kPa)	3MDW311-01

3M™ Water Filtration Products

Spec # _____

Quantity _____

Model # _____

Part # _____

Ordering Guide			
Model Name / Part #	3M ID	Previous 3M ID	UPC
3MDW301-01	7100090102	70-0202-4184-3	00016145231933
3MDW301-F	7100322916	70-0203-6659-0	0068060555298
3MDW311-01	7100090100	70-0202-4185-0	00016145231940

WARNING

Read entire product manual and Performance Data Sheet. Failure to follow all product instructions could cause personal injury from exposure to contaminants AND/OR property damage due to water leakage or flooding.

- System installation and use must comply with all state and local regulations and plumbing codes.
- DO NOT use with water that is microbiologically unsafe or of unknown quality without adequate disinfection before or after the system.
- If your water supply pressure is higher than 80 psi, you must install a pressure reducing valve before installing system.
- Filter cartridge must be replaced at the required intervals as stated on the product label and manual.
- For cold water use only
- The 3M™ Advanced Drinking Water Filtration System 3MDW301 has been tested and certified to NSF/ANSI standard 42, 53, 372 and/or 401 for the reduction of the substances listed in the system Performance Data Sheet. The system does not reduce all substances that could be present in your water.
- Do not use past the expiration date.

For Performance Data Sheet go to 3M.com/waterquality or contact 3M at 1-866-990-9785.

For additional product information, including product manual and spec sheets, contact 3M at 1 866 990-9785.

For additional information on cartridge replacements please go to 3M.com/waterquality.

Solventum recommends regularly scheduled maintenance and replacement of the filters in order for the product to perform as advertised. Solventum shall not be liable for system failures due to improper maintenance.

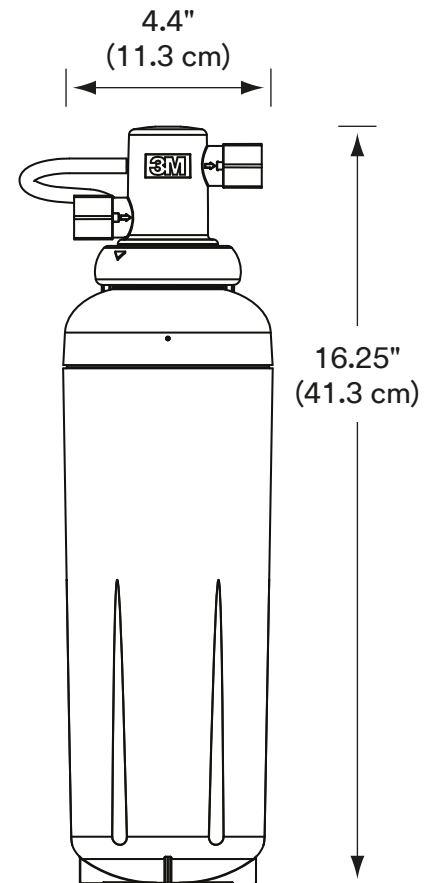

Installation Difficulty

Skills Needed: (Please refer to installation difficulty chart on website SPECIFICATIONS for additional information)



- Novice plumbing skills required if hole in sink is already present for dedicated faucet
- Professional installation recommended if no hole in sink is present for dedicated faucet

Limited Warranty and Limited Remedy: Solventum warrants that this product (excluding filter cartridge or filter membrane) will be free from defects in material and manufacture for the period of one (1) year from the date of purchase. SOLVENTUM MAKES NO OTHER EXPRESS OR IMPLIED WARRANTIES OR CONDITIONS, INCLUDING ANY IMPLIED WARRANTY OR CONDITION OF MERCHANTABILITY OR FITNESS FOR A PARTICULAR PURPOSE. If a Solventum product does not conform to this warranty, the sole and exclusive remedy is, at Solventum's option, replacement of the Solventum product or refund of the purchase price.

Limitation of Liability: Except for the limited remedy above, and except to the extent prohibited by law, Solventum will not be liable for any loss or damage arising from or related to the Solventum product, whether direct, indirect, special, incidental, or consequential, regardless of the legal or equitable theory asserted.

Solventum Corporation
3M Center, Building 275-6W
2510 Conway Avenue East
Maplewood, MN 55144

Phone 1-800-243-6894
1-203-237-5541

Web www.Solventum.com

Solventum, formerly 3M Health Care

© Solventum 2024. All rights reserved. Solventum and the S logo are trademarks of Solventum or affiliates. 3M is a trademark of 3M.

70-0202-4957-2 REV 1124