

In-line Office Water/Office Coffee Style Applications

OC and OW Series In-Line Sanitary Quick Change Filter Products



OC105-S
OW105

OC205-S
OW205
OW1005-L

The OC and OW Series water filtration products help protect beverage equipment and help provide consistent beverage quality.

The OC and OW Series water filtration products are an economical way to provide maximum equipment protection and consistent beverage quality for low volume office coffee and office water applications.

The encapsulated design minimizes contamination of the filtration media.

The compact footprint allows the unit to be installed behind the beverage unit or neatly under a cabinet.

The 1/4" quick connect connections allow direct adaptability to existing plumbing and provide ease of installation in tight spaces.

The sanitary quick change (SQC) encapsulated cartridge design allows for fast and easy cartridge change-outs.

Units are made of materials that are FDA, CFR-21 compliant for use in all food and beverage applications.

The OC205-S and OC105-S help protect equipment from the potentially damaging effects of lime scale.

Sediment, Chlorine Taste and Odor, Scale Reduction

OC105-S

Capacity: 1,000 gallons (3,785 liters) or 133 cups/day*

OC205-S

Capacity: 2,000 gallons (7,571 liters) or 266 cups/day*

Features

- 5 micron sediment reduction
- Chlorine taste and odor reduction
- Scale inhibition

Product Benefits

- Helps enhance beverage clarity
- Efficiently traps sediment
- Helps reduce maintenance caused by clogged valves and orifices
- Enhances beverages quality over the life of the filter
- Helps protect equipment from the potentially damaging effects of lime scale

Sediment and Chlorine Taste and Odor

OW105

Capacity: 1,000 gallons (3,785 liters) or 133 cups/day*

OW205

Capacity: 2,000 gallons (7,571 liters) or 133 cups/day*

Features

- 5 micron sediment reduction
- Chlorine taste and odor reduction

Product Benefits

- Helps enhance beverage clarity
- Efficiently traps sediment
- Helps reduce maintenance caused by clogged valves and orifice
- Enhances beverages quality over the life of the filter

Sediment, Chlorine Taste and Odor, Cyst** and Lead

OW1005-L

Capacity: 1,000 gallons (3,785 liters) or 133 cups/day*

Features

- 0.5 micron sediment reduction
- Cyst** and lead reduction

Product Benefits

- Helps protect the quality of the water by reducing filterable cyst** and lead

*Cups/day based on 8 oz cup (237 ml), 20 day work month and 6 month change-out schedule.

** Based on the use of Cryptosporidium parvum oocysts.

3M™ Water Filtration Products
OC and OW Series In-line Filter Products

Specified Model # _____

Part # _____

Price Quoted _____

Installed on what equipment _____

Quantity Required _____

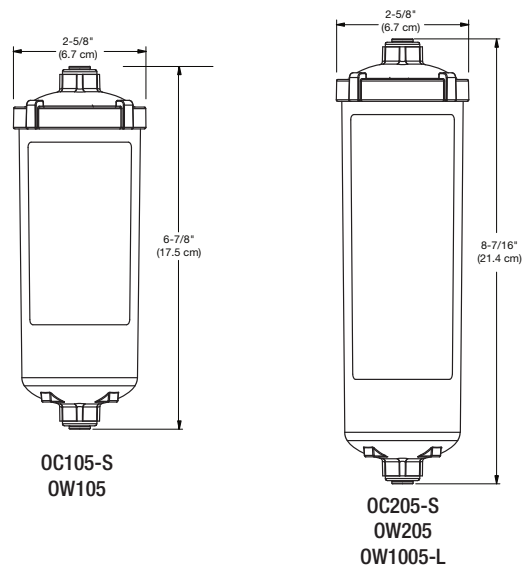

Applications/Specifications

Model#	Part#	Filter Dimensions in (cm)	Replacement Cartridge	Chlorine Taste and Odor	Scale* Inhibition	Sediment Reduction	Cyst Reduction	Lead Reduction	Capacity Gals (Liters)	Flow Rate gpm (lpm)	Case Qty
OC105-S	5628104	6-7/8 x 2-5/8 (17.5 x 6.7)	N/A	•	•	•			1,000 (3,785)	0.75 (2.83)	20
OC205-S	5628206	8-7/16 x 2-5/8 (21.4 x 6.7)	N/A	•	•	•			2,000 (7,571)	0.75 (2.83)	20
OW105	5628103	6-7/8 x 2-5/8 (17.5 x 6.7)	N/A	•		•			1,000 (3,785)	0.75 (2.83)	20
OW205	5628205	8-7/16 x 2-5/8 (21.4 x 6.7)	N/A	•		•			2,000 (7,571)	0.75 (2.83)	20
OW1005-L	5628204	8-7/16 x 2-5/8 (21.4 x 6.7)	N/A	•		•	•	•	1,000 (3,785)	0.5 (1.89)	20

*Tested and verified by manufacturer's laboratory.

These installation tips are for informational purposes only and are not intended to be used as actual installation instructions.

NOTICE: To reduce the risk associated with property damage due to water leakage or flooding:

- Read and follow all Instructions before installation and use of this system.

To reduce the risk of water leakage or flooding, and to ensure optimal filter performance:

- Change the disposable filter cartridge every six months or sooner if you observe a noticeable reduction in water flow rate.
- Failure to replace the disposable filter cartridge at recommended intervals may lead to reduced filter performance and cracks in the filter housing, causing water leakage or flooding.
- For questions or concerns, please contact Customer Service at 1-866-990-9785.

⚠ WARNING: To reduce the risk associated with the ingestion of contaminants: Do not use with water that is microbiologically unsafe or of unknown quality without adequate disinfection before or after the system. Systems certified for cyst reduction may be used on disinfected water that may contain filterable cysts. EPA Establishment #070595-MEX-001

Limited Warranty: 3M Purification Inc. warrants this Product to be free from defects in material and workmanship for one (1) year from the date of purchase. The disposable filter is warranted to be free from defects in material and workmanship for a period of one (1) year from the date of purchase. This warranty does not cover failures resulting from abuse, misuse, alterations or damage not caused by 3M Purification Inc. or failure to follow installation and use instructions. No warranty is given as to the service life of any filter cartridge or membrane as it will vary with local water conditions and water consumption. 3M PURIFICATION INC. MAKES NO OTHER WARRANTIES OR CONDITIONS, EXPRESS OR IMPLIED, INCLUDING, BUT NOT LIMITED TO, ANY IMPLIED WARRANTY OR CONDITION OF MERCHANTABILITY OR FITNESS FOR A PARTICULAR PURPOSE OR ANY IMPLIED WARRANTY OR CONDITION ARISING OUT OF A COURSE OF DEALING, CUSTOMER OR USAGE OF TRADE. If the Product fails to satisfy this Limited Warranty during the warranty period, 3M Purification Inc., at its option, will replace the Product or refund your Product purchase price. This warranty does not cover labor. The remedy stated in this paragraph is Customer's sole remedy and 3M Purification Inc.'s exclusive obligation. For additional information, see the entire Limited Warranty located in the product Installation and Operation Instruction Manual.

Limitation of Liability: 3M Purification Inc. will not be liable for any loss or damage arising from this 3M Purification Inc. product, whether direct, indirect, special, incidental, or consequential, regardless of the legal theory asserted, including warranty, contract, negligence or strict liability. Some states and countries do not allow the exclusion or limitation of incidental or consequential damages, so the above limitation or exclusion may not apply to you.

Distributed By: _____

