

3M™ Water Filtration Products

**Installation and Operating Instructions
for SCALEGARD™ LP REVERSE OSMOSIS
FILTRATION SYSTEM**

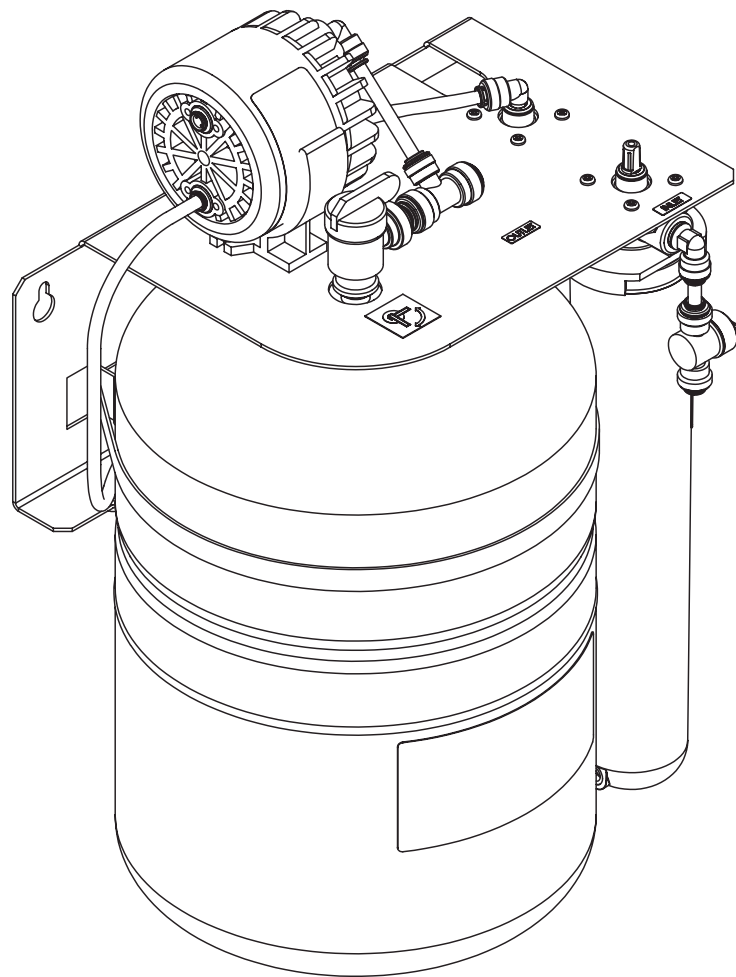

SGLP-RO

Installer: Please leave this manual with owner/operator.



LIMITED WARRANTY

3M Purification Inc. warrants SGLP-RO only to be free from defects in material and workmanship for two (2) years from the date of purchase. The disposable filter cartridge is warranted from defects in material and workmanship for a period of one (1) year from the date of purchase. This warranty does not cover failures resulting from abuse, misuse, alterations or damage not caused by 3M Purification Inc. or failure to follow installation and use instructions. No warranty is given as to the service life of any filter cartridge or membrane as it will vary with local water conditions and consumption. **3M PURIFICATION INC. MAKES NO OTHER WARRANTIES OR CONDITIONS, EXPRESS OR IMPLIED, INCLUDING, BUT NOT LIMITED TO, ANY IMPLIED WARRANTY OR CONDITION OF MERCHANTABILITY OR FITNESS FOR A PARTICULAR PURPOSE OR ANY IMPLIED WARRANTY OR CONDITION ARISING OUT OF A COURSE OF DEALING, CUSTOMER OR USAGE OF TRADE.** If the Product fails to satisfy this Limited Warranty during the warranty period, 3M Purification Inc., at its option, will replace the Product or refund your Product purchase price. This warranty does not cover labor. **The remedy stated in this paragraph is Customer's sole remedy and 3M Purification Inc.'s exclusive obligation.**

This warranty gives you specific legal rights, and you may have other rights which may vary from state to state, or country to country. For any warranty questions, please call 866.990.9785 or mail your request to: Warranty Claims, 3M Purification Inc., 400 Research Parkway, Meriden, CT 06450. Proof of purchase (original sales receipt) must accompany the warranty claim, along with a complete description of the Product, model number and alleged defect.

Limitation of Liability: 3M Purification Inc. will not be liable for any loss or damage arising from this 3M Purification Inc. product, whether direct, indirect, special, incidental, or consequential, regardless of the legal theory asserted, including warranty, contract, negligence or strict liability. Some states and countries do not allow the exclusion or limitation of incidental or consequential damages, so the above limitation or exclusion may not apply to you.

IMPORTANT INSTALLATION INSTRUCTIONS

Always follow these safety precautions when installing and operating the water filter system:

DO NOT use with water that is microbiologically unsafe or of unknown quality without adequate disinfection before or after the system.

DO NOT use a torch or other high temperature sources near filter or cartridge.

DO NOT install on line pressures above 125 psi (862 kPa).

DO NOT install on hot water line. Maximum temperature allowed is 100°F (38°C).

DO NOT install in direct sunlight.

DO NOT reverse connections. The system must be installed with the inlet and outlet as labeled.

DO NOT install filter system in locations where it can be damaged by other freestanding equipment.

DRAIN filter system at temperatures below 40°F (4.4°C). Protect from freezing.

INSTALLATION must comply with existing state or local plumbing codes.

This piece of equipment is made in America and has American sizes on hardware. All metric conversions are approximate and vary in size.

FEEDWATER PARAMETERS

Be sure to confirm that the feedwater falls within the limits shown below. If you're not sure if this has been done, check with your distributor before installing the system. This is important because failures caused by water related problems are not covered under the system warranty.

Feed TDS	Up to 2,000 ppm (mg/L)
Hardness*	<10 grains (171 mg/L)
Iron (Fe)	<0.1 mg/L
Hydrogen Sulfide	none allowable
Feed pH	4-11
Free chlorine	<2 mg/L
Manganese (Mn)	<0.05 mg/L
Turbidity	<5 NTU

* **NOTE:** For waters over 10 grain hard, a 3M water softener is recommended for pretreatment. Consult 3M technical services for correct sizing.

PARTS LIST

THE FOLLOWING PARTS ARE INCLUDED WITH THE SCALEGARD REVERSE OSMOSIS WATER FILTRATION SYSTEM. PLEASE UNPACK THE CONTENTS FROM THE PRODUCT BOX AND CHECK TO VERIFY THAT ALL OF THE PARTS LISTED BELOW ARE INCLUDED. SHOULD ANY PARTS BE MISSING, PLEASE CONTACT 3M PURIFICATION INC. AT 866.990.9785

QTY DESCRIPTION

- 1 TANK & BRACKET ASSEMBLY
- 1 PREFILTER CARTRIDGE
- 1 REVERSE OSMOSIS MEMBRANE CARTRIDGE
- 1 WATER SAMPLE VALVE ASSEMBLY (SEE FIGURE 1)
- 1 1' LENGTH OF 3/8" BLUE TUBING
- 1 10' LENGTH OF RED TUBING
- 1 ADAPTER - STEM X BARB (1/4X1/4")
- 1 ADAPTER - STEM X BARB (3/8 X 1/4")

MOUNTING

- 1) Remove the mounting bracket template from this manual. Tape it to the wall where the mounting bracket is to be installed.
- 2) Install mounting screws (not included) into each of the keyhole locations on the template. Be sure to leave a 1/8" to 1/4" space between the bottom of the screw head and the wall so that the bracket can be hung. **NOTE: Mounting hardware must be capable of supporting a minimum of 50 lbs (22.7 kg).**
- 3) Hang the Bracket/Tank Assembly from the mounting screws.
- 4) Once the bracket is hung, tighten the mounting screws so that the bracket is snug between the screw and the wall. **Note: Make sure that the bracket is securely mounted to a wall stud or other appropriate wall structure.**

PLUMBING CONNECTIONS

Note: The ScaleGard LP Reverse Osmosis Water Filtration System requires a minimum 50 psi inlet water pressure. If inlet water pressure is less than 50 psi, a water booster pump may be required. Refer to Figure 1 for proper tubing connections.

All connections are made with “Push-In” connectors. Refer to Figure 2 on the use of “Push-In” plastic fittings. Use care in routing the tubing to ensure that there are no bends or kinks.

- 1) Shut off water supply and water booster pump (if applicable).
- 2) Insert the 1/4" x 1/4" Stem X Barb Adapter (See Figure 1) into Inlet Water Valve. Run a 1/4" I.D. hose from the Water Supply or Booster Pump to the Inlet Water Valve.
- 3) Insert one end of the 3/8" blue tubing (included) into one end of the outlet tee on the RO system and the other end to one side of the Water Sample Valve Assembly. See Figure 1.
- 4) Insert the 3/8" x 1/4" Stem x Barb adapter into the open 3/8" port of the sample valve assembly. Run a 1/4" I.D. hose from the water sample valve assembly to the inlet of the Foodservice Equipment. See Figure 1.
- 5) Remove the white plug from the bottom port of the RO Module.
- 6) Remove the red cap from the RO module and moisten the o-rings with water. Insert the cartridge into the filter head. Be sure the ears on the cartridge line up with the spaces in the head. Then turn the cartridge 1/4 turn to the right.
- 7) Connect the 1/4" red tube from the “Brine In” side of the permeate pump to bottom port of the RO Module. (See Figure 3).
- 8) Run the separate 1/4" red tubing (included) from the “Brine Out” port of the permeate pump to the drain.

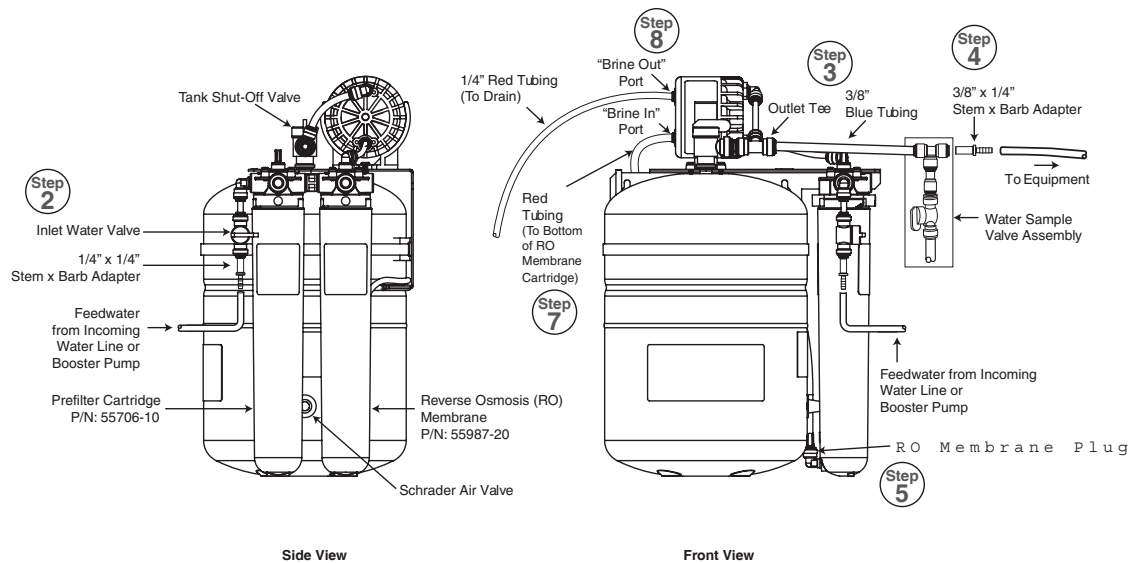

Figure 1

HOW TO USE 'PUSH-IN' CONNECTORS

This product is outfitted with user friendly 'Push In' connectors. Proper use of the connectors is shown in the diagrams. It is most important that the tubing selected for use with these connectors be of high quality, exact size and roundness, and with no surface nicks or scratches. If it is necessary to cut the tubing, use a plastic tubing cutter or sharp razor knife. Make a clean square cut.

Should a leak occur at a 'Push-In' connector, the cause is usually defective tubing.

To Fix: **1. Relieve pressure** **2. Release tubing** **3. Cut off at least 1/4" from end**
4. Reattach tubing **5. Confirm connection is leak free**

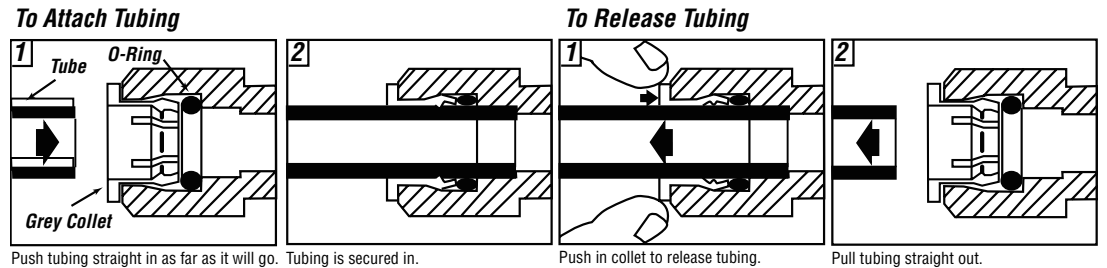

Figure 2

SYSTEM START-UP

- 1) Remove the prefilter cartridge from its packaging. Remove the red cap from the cartridge and moisten the o-rings with water. Insert the cartridge into the filter head. Be sure that the ears on the cartridge line up with the spaces in the head. Then, turn the cartridge 1/4 turn to the right.
Note: Be sure to install the cartridge into the proper head by matching the icon on the cartridge label with the icon on the head.
- 2) Check that all plumbing connections are secure.
- 3) Open the tank shut-off valve and inlet water valve. Turn on the incoming water supply or beverage booster pump (if applicable) and check the system for leaks. If any leaks are noted, turn off the water supply and/or booster pump and correct the leak before proceeding. If a leak is detected at a push-in fitting, refer to Figure 2.
- 4) Divert the Water Sample Valve outlet to drain. Open valve and let water run through the RO to drain for 10 minutes.
- 5) Close sample valve.
- 6) Allow tank to fill (Approximately 60 minutes).
- 7) Open Water Sample Valve outlet to drain. Empty tank. Water flowing from tank will reduce to a fast drip when tank is empty.
- 8) Allow product water to run to drain for 60 minutes.
- 9) Close sample valve and allow the tank to fill (Approximately 60 minutes).

CARTRIDGE & RO MEMBRANE CHANGE INSTRUCTIONS

Cartridge (Replace every 6 months)

1. Close tank shut-off and inlet valves (see Fig. 1).
2. Turn used prefilter cartridge 1/4 turn to the left.
3. Pull down on cartridge.
4. Discard used cartridge.
5. Remove red cap from new cartridge and moisten the o-ring with water.
6. Insert new cartridge into the filter head. Be sure that the ears on the cartridge line up with the spaces in the head.
7. Turn new cartridge 1/4 turn to the right.
8. Open tank shut-off and inlet valves (see Fig. 1).
9. Check for leaks.

CARTRIDGE & RO MEMBRANE CHANGE INSTRUCTIONS *(continued)*

Flush Instructions

1. Close tank valve.
2. Open Water Sample Valve and divert to drain for 5 minutes.
3. Close Water Sample Valve and open tank valve.

Note: Be sure to install the cartridge into the proper head by matching the icon on the cartridge label with the icon on the head.

Membrane (Replace every 36 months)

1. Close tank shut-off and inlet valves (see Fig. 1).
2. Turn used RO module cartridge 1/4 turn to the left.
3. Pull down on cartridge.
4. Remove the red tubing from the fitting (refer to Figure 3).
5. Discard used cartridge.
6. Remove red cap from new module and moisten the o-ring with water.
7. Remove the plug from the RO Module.
8. Insert the red tubing from Step 4 into the new module.
9. Insert of new cartridge into the filter head. Be sure that the ears on the cartridge line up with the spaces in the head.
10. Turn new cartridge 1/4 turn to the right.
11. Open sample valve and divert to drain.
12. Open inlet valve and allow system to run for 30 minutes.
13. Flush membrane — follow steps 4 to 9 under system start up instructions.

Note: Be sure to install the cartridge into the proper head by matching the icon on the cartridge label with the icon on the head.

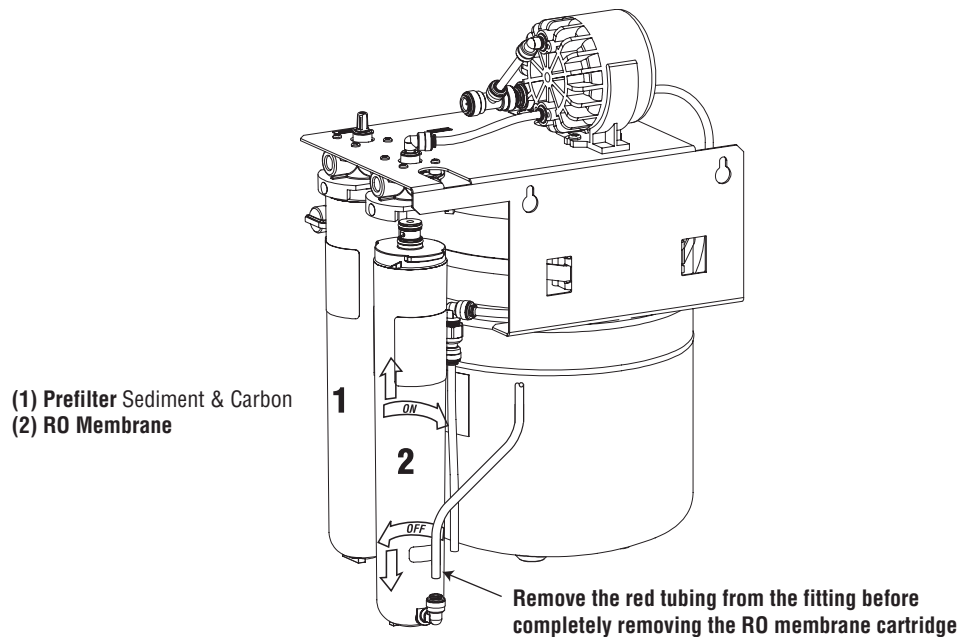

Figure 3

CHECK TANK PRESSURE

WHEN: Yearly

TOOLS:

Piece of 3/8" tubing OR Bucket

Bicycle or tire pressure gauge

Bicycle tire pump

1. Drain water from the storage tank.
 - a. Shut off the inlet water valve or water booster system if applicable.
 - b. Make sure the tank shut-off valve located at the top of the water tank is open.
 - c. Attach a piece of tubing from the water sample valve to drain OR use a bucket to catch water from the water sample valve.
 - d. Open the water sample valve and drain the tank until empty. Leave water sample valve open.
2. Unscrew the blue cap on the side of the tank to expose the Schrader Air Valve.

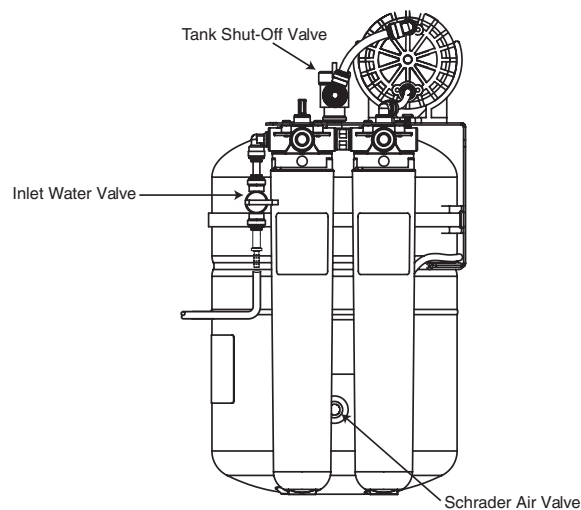

3. Using a standard bicycle or automobile tire pressure gauge that is capable of reading pressure accurately from 0-10 psi. Connect the air pressure gauge to the Schrader Air Valve on the water tank.
4. Read the tank's air pressure.
5. The air pressure should be between 8 and 10 psi.
6. If the air pressure is below 8 psi or above 10 psi complete the following steps.
 - a. Using a standard bicycle pump add or release air pressure in the tank.
 - b. Repeat Steps 4-5 until the pressure is 8-10 psi.
 - c. Make sure the blue cap is replaced on the air pressure port.
7. Close the water sample valve.
8. Turn on the inlet water valve and/or booster system (if applicable).
9. Allow 60 minutes for tank to fill before operating equipment.

Product Dimensions (Figure 4)

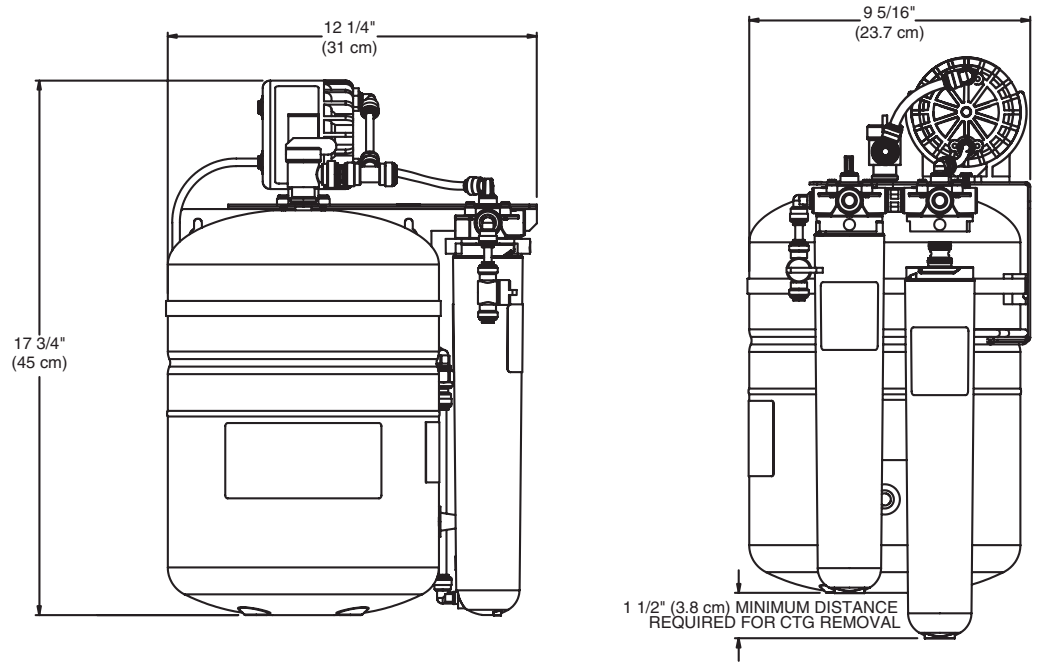

Replacement Parts

Part Number	Description
54-3030	Stainless steel bracket complete with filter heads and RO shut-off valve
56-161351	Tank
60-23296	Tank shut-off valve
30-6049	Tank banding clamp
55706-10	Prefilter cartridge
55987-20	RO module
60-232270	Inlet water valve
82-11302	3/8" blue tubing (1 ft)
82-11205	1/4" red tubing (10 ft)
53-52001	Flow Control Assembly
68512-03	Water Sample Valve Assembly (Includes 3/8" Tee, 3/8" x 1/4" Adapter, and 1/4" Shut off valve)
74-3560404	1/4" x 1/4" Stem x Barb Adapter
74-3560606	3/8" x 1/4" Stem x Barb Adapter
89-1331202	Permeate Pump

Troubleshooting Guide

Problem	Cause	Solution	Notes
Unit Runs Low or Out of Water	Low Feed Water Pressure	Repair Existing Booster Pump / System (If Applicable)	Contact Dealer
		Add Water Booster Pump	Only if Beverage Booster System is not installed
	RO Membrane Fouled	Replace RO Module	Feed Water Pressure, Temperature, RO Module Flow Rate and Reject Flow Rate should be checked before replacing Module
	Storage Tank Air Charge is Low	Drain Tank using Sample Valve, with Sample Valve Open, Pump-Up Air Charge, 8 to 10 psi, Close Sample Valve	Unscrew Blue Cap to Access Schrader Air Valve
	Pre-Filter is Plugged by Sediment (Particles)	Replace Pre-Filter	A more frequent pre-filter change-out schedule may be needed
	Slow Leak In the Distribution Line	Repair Leak	The unit produces pure water slowly. A dripping leak can prevent the tank from filling
Unit Never Shuts Off (Continually Runs to Drain)	RO Membrane Partially Fouled, Unit can not produce enough water to keep up with demand	Replace RO Module	High levels of hardness minerals may be present in feed water, monitor reject flow for plugging
	Product Water Check Valve has Failed allowing storage tank flow to drain after unit has shut-off	Check Reject Water flow to drain in the morning. Unit should be off and no flow to drain. If flow to drain exists, turn off the feed water valve and check for flow to drain in 10 minutes. If flow to drain remains steady, replace RO Module.	Reject Water flow to drain should stop when the feed water valve is off.

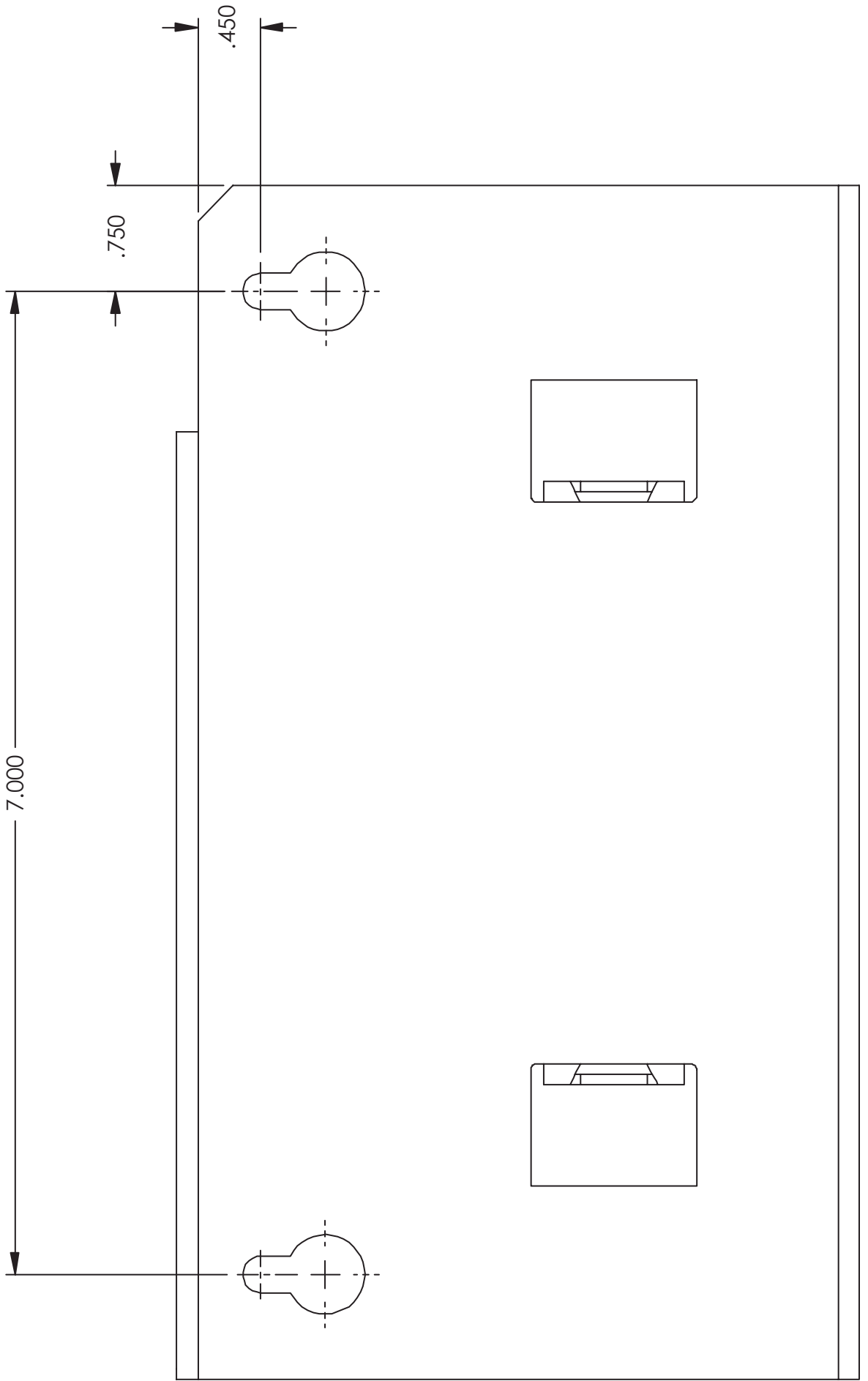

3M is a trademark of 3M Company.
INSTR4232 0912B
© 2012 3M Company. All rights reserved.
Please Recycle. Printed in U.S.A.



3M Purification Inc.
400 Research Parkway
Meriden, CT 06450 USA
Toll Free: 866.990.9785
Worldwide: 203.237.5541
Fax: 203.238.8701
www.3Mfoodservice.com
www.3Mpurification.com