

3M Medical Materials & Technologies

Frequently Asked Questions & Converting Tips for:

3M™ Medical #4075 Extended Wear Transfer Adhesive

Effective: March 2019

Supersedes all previous versions

Appearance and Converting Suggestions:

#4075 is a thick, relatively soft tackified acrylic adhesive provided on a thin, clear polyester liner with differential silicone release chemistry on both sides. There is a slight yellowish color to most acrylic-based adhesives especially those that are tackified. This is normal and only evident when multiple layers are visible – such as the rolls of #4075.

The soft, thick adhesive tends to dry more slowly in the ovens during production. This results in a somewhat more “mottled” or uneven upper or face side surface when it is wound/unwound. The mottling – often referred to as “fish eyes”, “orange peel”, “laking”, or other similar terms – is cosmetic and does not affect the adhesion properties or performance of the transfer adhesive based on testing done by 3M Medical Materials & technologies during our commercialization. Taking care during any lamination steps in converting by keeping the adhesive surface from contacting the lamination substrate except at the point of necessary contact under the nip roll will help prevent air pockets becoming trapped between layers.

A differential release liner is typically used for double-coated & transfer adhesives. This type of release liner design helps ensure that when the product is unwound, the adhesive stays with one side of the release liner [the side with slightly tighter or higher release values] to reduce chances of “liner confusion”. This problem occurs when adhesive switches back & forth during the breakaway from the release surfaces intermittently making unwinding and laminating to other materials more difficult. To help encourage correct unwind, especially at start-up, a small diameter “breaker bar” or “lay-on” roller can be used to ensure that the angle of unwind is as close as possible to back on itself as possible. If using a secondary liner, try cutting parts with the original film liner on top of the stack for best results.

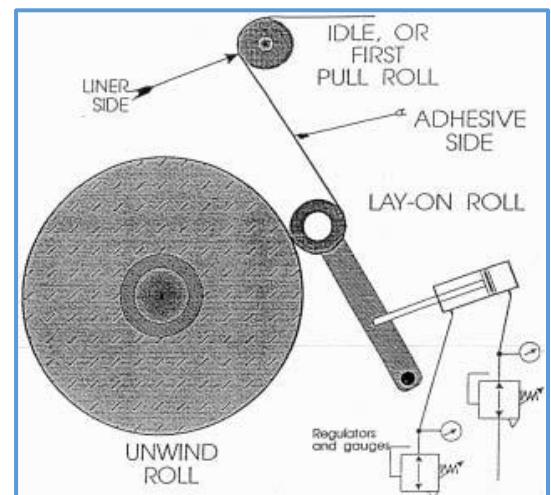

Storage:

Store in the original packaging in areas where the temperature & humidity levels are controlled. Keeping the rolls in the packaging also prevents any possible damage from strong lighting – indoor or outdoor – which may affect the color and other properties over time. This is a soft, thick adhesive coating and long-term storage at higher temperatures [$>120\text{degF}/50\text{degC}$] may result in adhesive flow to the edges which could cause problems with unwinding and possibly a loss of overall adhesive thickness and make the coating uneven across the web. Colder storage shouldn't be a problem if the rolls are allowed to return to standard room temperatures and remain protected in the original packaging to help reduce condensation.

Product and Safety Information: User is solely responsible for determining the suitability of 3M samples and products for the intended use including any necessary safety or biocompatibility assessments. A summary of the 3M biocompatibility testing results is available at 3M.com/MedTech. 3M Article Information Sheets (AIS), equivalent to a Safety Data Sheet, and regulatory documents [RDS] are available through the 3M.com/sds website link. In every case before using any product in full scale production users should conduct their own tests to determine to their own satisfaction whether the product is of acceptable quality and is suitable for their particular purposes under their own operating conditions.

Notice: Nothing contained herein shall be construed to imply the nonexistence of any relevant patents or to constitute a permission, inducement or recommendations to practice any invention covered by any patent, without authority from the owners of this patent.

Warranty Information

All statements, technical information and recommendations herein are based on tests 3M believes to be reliable, but the accuracy or completeness thereof is not guaranteed. 3M warrants only that products will meet 3M's specifications at the time of shipment to the customer. 3M does not offer any other warranty and does not warrant the performance, safety or such other characteristics of Products in combination with other materials. 3M specifically DOES NOT warrant Products for any intended or unintended uses (whether or not foreseeable); for compatibility or suitability with other components or compatibility with any methods of manufacture or conversion. The foregoing warranty is made in lieu of all other warranties, expressed or implied, including the implied warranties of merchantability, fitness for a particular purpose and freedom from non-infringement.

Limitation of Remedies: If products are proven not to meet 3M's specifications, the sole and exclusive remedy available and 3M's only obligation shall be, at 3M's option, to replace such quantity of Products which are proven out of specification or to refund the purchase price paid for Products.

Limitations of Liabilities: The remedies provided herein are exclusive remedies against 3M for any alleged or actual nonconformance to specifications or defect or other failure in products or for 3M's performance of its supply obligations. Under no circumstances is 3M liable for any direct, indirect, incidental, special or consequential damages (including lost profits) in any way related to the product under any theory of law including, but not limited to, negligence and strict liability.

Ordering Information

To place an order, call our Customer Service at: 800-742-1994 (U.S.). For all orders outside the United States, please contact your local country representative or visit 3M.com/MedTechFindaRep for your region's contact information.

To have a sales representative contact you, to request samples or clinical and safety summaries, please contact us at 3M HELPLINE 800-228-3957 (U.S.) or 3M.com/MedTechContactUs for your region's contact information.

Visit our website: www.3M.com/MedTech for product and services information, news, events, new product highlights or to make a direct inquiry.



Medical Materials & Technologies

3M Center, Building 275-5W-05
St. Paul, MN 55144-1000 USA

Phone 1-800-228-3957
Web 3M.com/MedTech

3M is a trademark of 3M.

Please recycle. Printed in U.S.A.

© 3M 2019. All rights reserved.

Effective March 2019