

3M™ Water Filtration Products

Installation and Operation Instructions for CFS1254 Water Softeners

Installer: Please leave this manual with owner/operator.
Owner/Operator: Please retain for operation and future instructions.



NOTES



SAFETY INFORMATION

Read, understand, and follow all safety information contained in these instructions prior to installation and use of the CFSM1254 water softener. Retain these instructions for future reference. Failure to follow installation, operation and maintenance instructions may result in property damage and will void warranty.

Intended use:

The CFSM1254 water softener is intended for use in softening water in foodservice establishments and has not been evaluated for other uses. The system must be installed indoors near the point of use, and be installed by qualified professional installers according to these installation instructions.

EXPLANATION OF SIGNAL WORD CONSEQUENCES

 WARNING	Indicates a potentially hazardous situation, which, if not avoided, could result in death or serious injury and/or property damage.
 CAUTION	Indicates a potentially hazardous situation, which, if not avoided, may result in minor or moderate injury and/or property damage.
CAUTION	Indicates a potentially hazardous situation, which, if not avoided, may result in property damage.

WARNING

To reduce the risk associated with choking:

- Do not allow children under 3 years of age to have access to small parts during the installation of this product.

To reduce the risk associated with ingestion of contaminants:

- Do not use with water that is microbiologically unsafe or of unknown quality without adequate disinfection before or after the system.
- Before using, flush any new water treatment system with water according to the installation instructions.

To reduce the risk of physical injury:

- Shut off inlet water supply and depressurize system as shown in manual prior to service.

To reduce the risk associated with a hazardous voltage:

- If the electrical system requires use of the cold water system as an electrical safety ground, a jumper must be used to ensure a sufficient ground connection across the water softener installation piping — refer installation to qualified personnel.
- Do not use the system if the power cord is damaged — contact qualified service personnel for repair.

To reduce the risk associated with back strain due to the heavy weight of the various system components:

- Follow safe lifting procedures.

CAUTION

To reduce the risk associated skin, eye, and respiratory tract irritation from gravel and filter media during installation:

- Gravel and several types of filter media may be used in this product, depending upon the application. During installation, dust may cause irritation to skin, eyes, and respiratory tract.
- Utilize a NIOSH-approved dust filter mask, protective gloves, and appropriate eye protection when handling and pouring gravel and filter media.
- To request an MSDS relating to the media shipped with this product, call 203-238-8965 or go to www.3M.com, select country, and use the search engine to search MSDS. For emergencies, call 800-364-3577 or 651-737-6501 (24 hours).

CAUTION

To reduce the risk associated with property damage due to water leakage:

- **Read and follow** Use instructions before installation and use of this water treatment system.
- Installation and use **MUST** comply with existing state or local plumbing codes.
- **Protect from freezing**, relieve pressure and drain system when temperatures are expected to drop below 40°F (4°C).
- **Do not** install on hot water supply lines. The maximum operating water temperature of this water softener is 110°F (43°C).
- **Do not** install systems in areas where ambient temperatures may go above 110°F (43.3°C) or below 40°F (4.4°C).
- **Do not** install if water pressure exceeds 125 psi. If your water pressure exceeds 80 psi (552 kPa), you must install a pressure limiting valve. Contact a plumbing professional if you are uncertain how to check your water pressure.
- **Do not** install where water hammer conditions may occur. If water hammer conditions exist you must install a water hammer arrester. Contact a plumbing professional if you are uncertain how to check for this condition.
- Where a backflow prevention device is installed on a water system, a device for controlling pressure due to thermal expansion must be installed.
- **Do not** use a torch or other high temperature sources near system.
- On plastic fittings, never use pipe sealant or pipe dope. **Use PTFE thread tape only**, pipe dope properties may deteriorate plastic.
- Take care when using pliers or pipe wrenches to tighten plastic fittings, as damage may occur if over tightening occurs.
- **Do not** install in direct sunlight or outdoors.
- Install system in such a position as to prevent it from being struck by other items used in the area of installation.
- Ensure all tubing and fittings are secure and free of leaks.
- **SHUT OFF FUEL OR ELECTRIC POWER SUPPLY TO WATER HEATER** after water is shut off.
- **Do not** install system where water lines could be subjected to vacuum conditions without appropriate measures for vacuum prevention.
- **Do not** apply heat to any fitting connected to bypass or control valve as damage may result to internal parts or connecting adapters.
- Install on a flat/level surface. It is also advisable to sweep the floor to eliminate objects that could pierce the brine tank.

To reduce the risk associated with property damage due to plugged water lines:

- Pay particular attention to correct orientation of control valve. Water flow should match arrow on control valve. The Inlet and Outlet of other water treatment equipment products will vary depending on the control valve brand used.

IMPORTANT NOTES

- Failure to follow instructions will void warranty.

TABLE OF CONTENTS

<u>SECTION</u>	<u>DESCRIPTION</u>
1	BEFORE INSTALLATION
2	INSTALLATION
3	CONTROL VALVE PROGRAMMING & REGENERATION
4	MAINTENANCE
5	CONTROL VALVE TROUBLESHOOTING GUIDE & SERVICE INSTRUCTIONS
6	SYSTEM TROUBLESHOOTING GUIDE
7	SPECIFICATIONS & OPERATING DATA
8	PARTS
9	LIMITED WARRANTY

SECTION 1: BEFORE INSTALLATION

When properly installed, operated, and maintained, your new water softener will provide years of dependable service. Before starting the installation, please read this entire manual for an overview, and then follow the installation instructions. **Failure to follow the instructions will void the warranty.**

Inspecting And Handling Your Water Softener:

Inspect shipping carton and the equipment for shipping damage. If damaged, notify the transportation company and request a damage inspection.

Handle the equipment with care. Damage can result if dropped or if the brine tank is set on sharp, uneven projections on the floor. When handling, do not turn the water softener unit upside down or on its side to help prevent media from entering valve and being discharged downstream.

Make Sure Your Water Has Been Thoroughly Tested:

An analysis of your water should be made prior to the selection of your water softener. You can typically get this service through your place of purchase, which may require sending a sample to the factory for analysis and recommendations. Enter your analysis below for your permanent record.

Analysis of Your Water:

Hardness _____ gpg	Tannins (Humic Acid) _____ ppm
Iron (Fe) _____ ppm	Hydrogen Sulfide (H ₂ S) _____ ppm
Manganese (Mn) _____ ppm	Other _____ ppm
pH _____	Other _____ ppm

IMPORTANT NOTES

The test for Hydrogen sulfide (H₂S) must be completed at the well site. For accuracy, the sample must be drawn with the pump RUNNING, and the test be completed within ONE (1) minute after the sample is drawn.

Water softeners are designed to reduce hardness but can handle reasonable amounts of soluble iron if consideration is given to iron content when selecting model and regeneration settings. To treat sulfur (hydrogen sulfide), bacterial iron, precipitated iron or very high levels of soluble iron special equipment in addition to a water softener is required. For best results, an iron reduction system is recommended for use on waters containing more than 2 ppm of iron.

Check Your Pumping Rate and Water Pressure:

Two water system conditions must be checked carefully to avoid unsatisfactory operation or equipment damage:

- 1) MINIMUM water pressure required at the water softener inlet is 20 psi (138 kPa).

CAUTION

To reduce the risk associated with property damage due to water leakage:

- Do not install if water pressure exceeds 125 psi. If your water pressure exceeds 80 psi (552 kPa), you must install a pressure limiting valve. Contact a plumbing professional if you are uncertain how to check your water pressure.

NOTE: If you have a municipal or a community water supply and daytime water pressure is 80 psi or more, nighttime pressure may exceed 125 psi. Call your local water department or plant operator to obtain pressure readings. If you have a private well, the gauge on the pressure tank will indicate the high and low system pressure. Record your water pressure data below:

Water Pressure:

Low _____ psi

High _____ psi

CAUTION

To reduce the risk associated with property damage due to water leakage:

- Do not install system where water lines could be subjected to vacuum conditions without appropriate measures for vacuum prevention.

The installer is required to take appropriate measures if there is the possibility a vacuum condition may occur. This would include the installation of an appropriate device in the supply line to the system, i.e., a vacuum breaker or backflow prevention device. Vacuum damage voids the factory warranty.

- 2) The pumping rate of your well must be sufficient for satisfactory operation and backwashing of the water softener. (See Specifications And Operating Data, Section 7).

IMPORTANT NOTES

If sediment is present, the installation of a sediment pre-filter is recommended. Even if sediment is not currently present or at a level high enough to be objectionable, a pre-filter can help increase the efficiency of the softener and help reduce the amount of maintenance required.

Installation Site Selection:

Select the location of your water softener with care. Various conditions which contribute to proper location are as follows:

- 1) Locate as close as possible to water supply source.
- 2) Locate as close as possible to a drain.
- 3) Locate in correct relationship to other water conditioning equipment (Figure 1, page 2-1).
- 4) Locate the water softener in the supply line BEFORE the water heater. Temperatures above 110°F (43°C) will damage the water softener and void the factory warranty.
- 5) DO NOT install the water softener in a location where freezing temperatures occur. Freezing may cause permanent damage and will also void the factory warranty.
- 6) Allow sufficient space around the installation for easy servicing.
- 7) Provide a non-switched 110V, 60Hz (220V, 50Hz for specified systems) power source for the control valve.

WARNING

To reduce the risk associated with ingestion of contaminants:

- Do not use with water that is microbiologically unsafe or of unknown quality without adequate disinfection before or after the system.

CAUTION

To reduce the risk associated with property damage due to water leakage:

- Protect from freezing, relieve pressure and drain system when temperatures are expected to drop below 40°F (4°C).
- Do not install on hot water supply lines. The maximum operating water temperature of this water softener is 110°F (43°C).
- Do not install systems in areas where ambient temperatures may go above 110°F (43.3°C) or below 40°F (4.4°C).
- Do not install in direct sunlight or outdoors.

Facts to Remember While Planning The Installation:

- 1) All installation procedures **MUST** conform to local and state plumbing codes.
- 2) Remember that the water softener **INLET** is attached to the pipe that supplies water (i.e. delivers water from the well pump or after the water meter) and the **OUTLET** is the line that runs toward the water heater.

CAUTION

To reduce the risk associated with property damage due to plugged water lines:

- Pay particular attention to correct orientation of control valve. Water flow should match arrow on control valve. The Inlet and Outlet of other water treatment equipment products will vary depending on the control valve brand used.

- 3) Before beginning the installation review the existing piping system and to determine the size, number and type of fittings required.

WARNING

To reduce the risk associated with a hazardous voltage:

- If the electrical system requires use of the cold water system as an electrical safety ground, a jumper must be used to ensure a sufficient ground connection across the water softener installation piping — refer installation to qualified personnel.

- 4) Sweep the floor to eliminate objects that could pierce the brine tank.

IMPORTANT NOTE

SODIUM INFORMATION: Water softeners using sodium chloride for regeneration add sodium to the water. People who are on sodium restricted diets should consider the added sodium as part of their overall sodium intake.

SECTION 2: INSTALLATION

TYPICAL WELL INSTALLATION

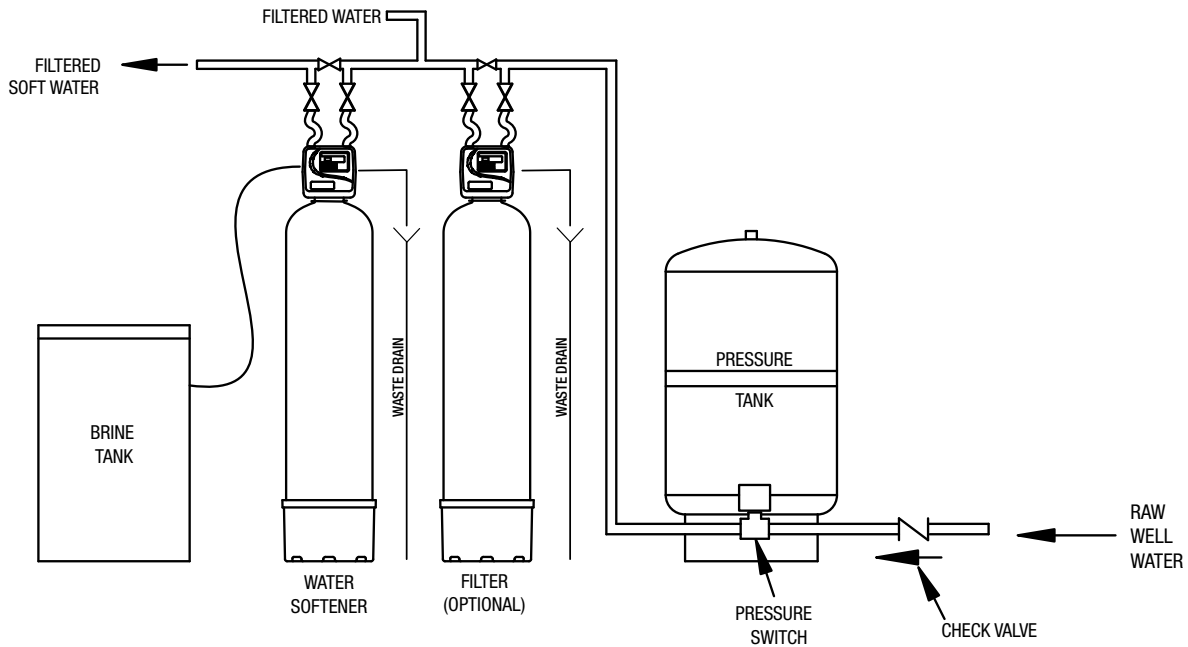

PUBLIC WATER SUPPLY INSTALLATION

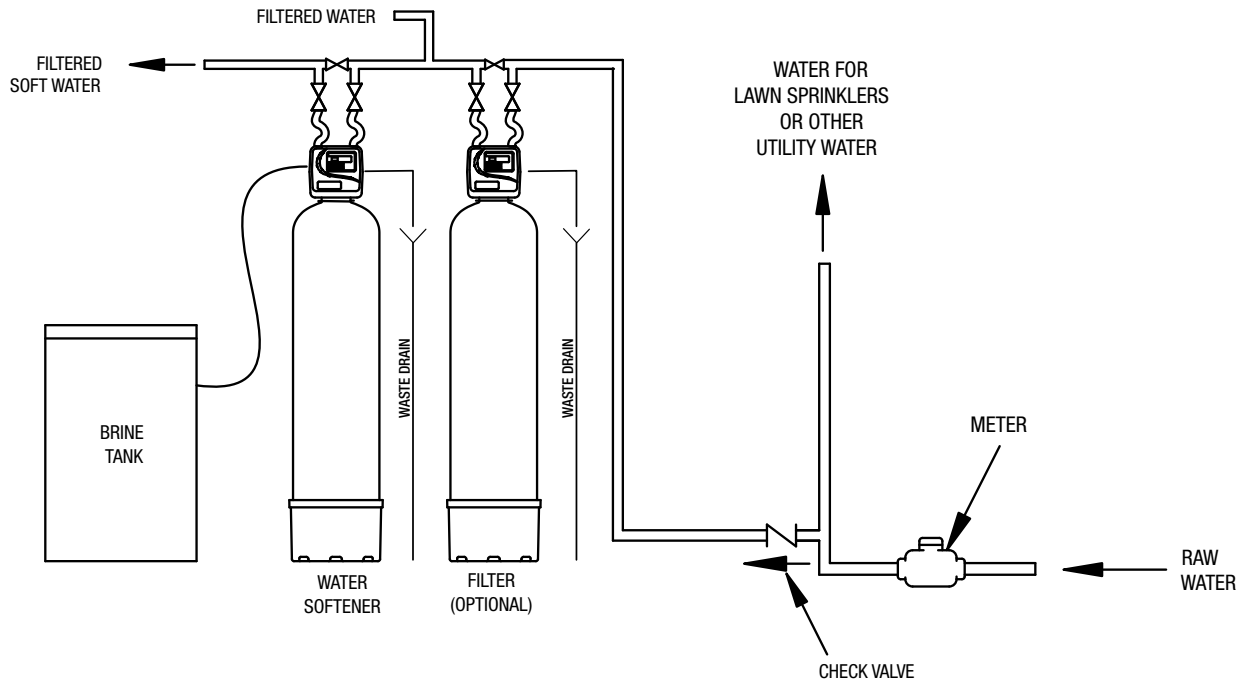

Figure 1. Typical Installation

CAUTION

To reduce the risk associated with property damage due to water leakage:

- **Read and follow** Use instructions before installation and use of this water treatment system.
- Installation and use **MUST** comply with existing state or local plumbing codes.

To reduce the risk associated with property damage due to plugged water lines:

- Pay particular attention to correct orientation of control valve. Water flow should match arrow on control valve. The Inlet and Outlet of other water treatment equipment products will vary depending on the control valve brand used.

Step 1) Remove unit from shipping box, inspect for damage and ensure all parts needed for installation are present. If parts are missing please contact our customer service department for help @ 1-866-990-9785. Remove the packing from unit and discard according to local, state and federal regulations. Locate the parts package and install the bypass and adapter fittings on the control valve to facilitate the connection to the customer's water supply.

CAUTION

To reduce the risk associated with property damage due to water leakage:

- On plastic fittings, never use pipe sealant or pipe dope. **Use PTFE thread tape only**, pipe dope properties may deteriorate plastic;
- Take care when using pliers or pipe wrenches to tighten plastic fittings, as damage may occur if over tightening occurs.

Step 2) Verify all packaging materials have been removed from the brine tank. On all units, legs rest on bottom of the brine tank. **Models utilizing 15" x 15" x 34" brine tanks require salt grid extension legs when salting the softener above 15 lbs. of salt or more.**

Step 3) Shut off all water at main supply valve. On a private well system, turn off power to the pump and drain the pressure tank. Make certain pressure is relieved from the complete system by opening the faucet closest to the system.

CAUTION

To reduce the risk associated with property damage due to water leakage:

- **SHUT OFF FUEL OR ELECTRIC POWER SUPPLY TO WATER HEATER** after water is shut off.

Step 4) Cut main supply line as required to fit plumbing to inlet and outlet of unit.
 a. Locate the bypass valve assembly. Using the connection fittings attached to the bypass valve assembly, screw onto the existing threaded assembly on the control valve, hand tighten only.
 b. Ensure the bypass valve is placed into the bypass position as shown in Figure 2 until instructed to place into the service position.

Step 5) Attach plumbing. **DO NOT** apply heat to any fitting connected to bypass or control valve as damage may result to internal parts or connecting adapters. Make certain water flow enters through inlet and discharges through outlet.

You will need to assemble the 1" NPT male connection fitting before you attach it to the bypass valve. Please refer to Figure 2 below to correctly assemble the connection fitting. Attach the plumbing to the 1" NPT male connection fittings, hand tighten the fitting nuts only. Be careful not to apply heat to any plastic part when making the connection of the plumbing to the connection fittings. Utilize only thread sealant tape to seal any NPT fittings that connect to the connection fittings. Both NPT connections utilize an o-ring to prevent a leak.

Next connect the connection fittings to the bypass valve attached to the control valve. Be cautious not to over tighten the fittings as damage to these items are not covered under the product warranty, and may cause water damage to your home or facility. Make certain the water enters the inlet and discharges through the outlet sides of the bypass valve. Arrows on the bypass valve indicate water flow. Refer to SECTION 6: COMPONENT LIST AND ASSEMBLIES for an assembly drawing on the connector. Please Note: leave the bypass valve in the bypass position until you are ready to regenerate the water softener. Attach the bypass to the control valve. Hand tighten the connections.

Fitting Installation Instructions

1. The installation fittings are designed to accommodate minor plumbing misalignments, but are not designed to support the weight of a system or plumbing line and fittings.
2. Thread tape is the only type of thread sealant allowed to be used; the use of paste of any kind will void the factory warranty.
3. Slide the nut on first (closed and against the threads), then slip the split ring onto the fitting, ensuring it set correctly in groove, then the o-ring last. Use Silicone lubricant to allow for easier insertion of parts into one another.
4. Hand tighten the nut only, the use of pliers or wrenches of any type will void the factory warranty and may cause an unexpected failure and water leak in your home or facility.

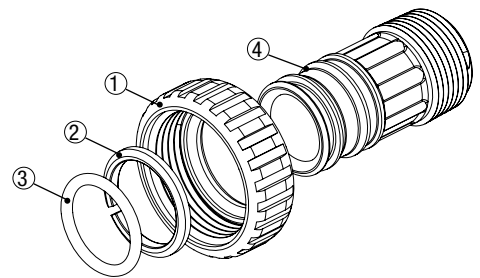

Figure 2. Fitting Installation Instructions

⚠ WARNING

To reduce the risk associated with a hazardous voltage:

- If the electrical system requires use of the cold water system as an electrical safety ground, a jumper must be used to ensure a sufficient ground connection across the water softener installation piping — refer installation to qualified personnel.

CAUTION

To reduce the risk associated with property damage due to water leakage:

- **Do not** apply heat to any fitting connected to bypass or control valve as damage may result to internal parts or connecting adapters.

To reduce the risk associated with property damage due to plugged water lines:

- Pay particular attention to correct orientation of control valve. Water flow should match arrow on control valve. The Inlet and Outlet of other water treatment equipment products will vary depending on the control valve brand used.

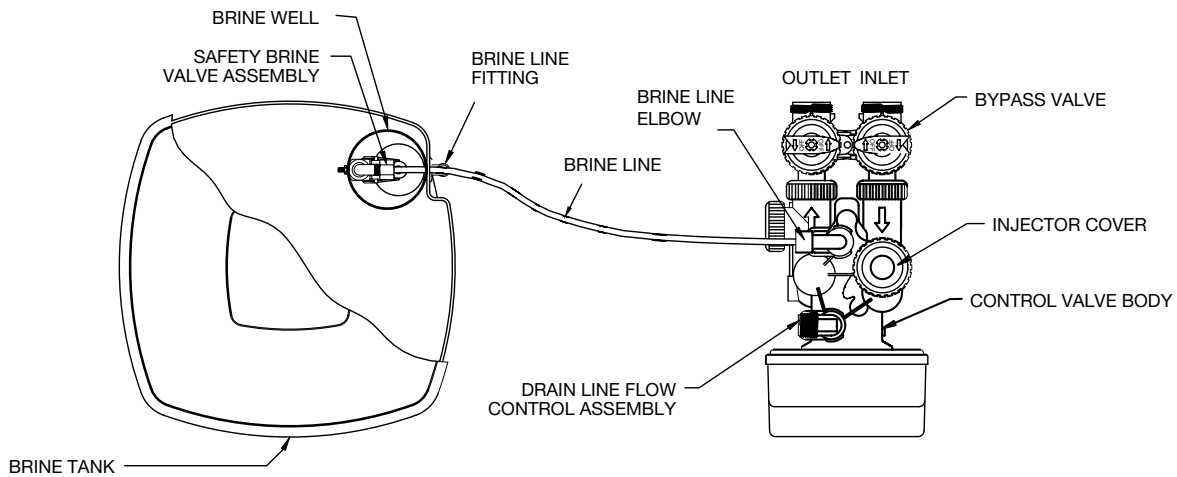

Figure 3. Softener and Brine Tank Assembly, Top View

Step 6) The control valve allows for either a 3/4" NPT connection or 5/8" poly tubing for use as a drain line connection.

CAUTION

To reduce the risk associated with property damage due to water leakage:

- On plastic fittings, never use pipe sealant or pipe dope. Use PTFE thread tape only, pipe dope properties may deteriorate plastic;
- Take care when using pliers or pipe wrenches to tighten plastic fittings, as damage may occur if over tightening occurs.

Step 7) Attach drain line to drain line fitting. To prevent back pressure from reducing flow rate below minimum required for backwash, the drain line MUST BE sized according to run length and relative height. Be careful not to bend flexible drain tubing sharply enough to cause "kinking" (if kinking occurs drain line MUST BE replaced). Typical examples of proper drain line diameters are:

- 1) 1/2" ID up to 15 ft. when discharge is lower than inlet.
- 2) 5/8" ID up to 15 ft. when discharge is slightly higher than the inlet.
- 3) 3/4" ID when drain is 25 ft. away and/or drain is installed overhead.

Some areas prohibit the use of flexible drain lines. Check your local plumbing code prior to installation.

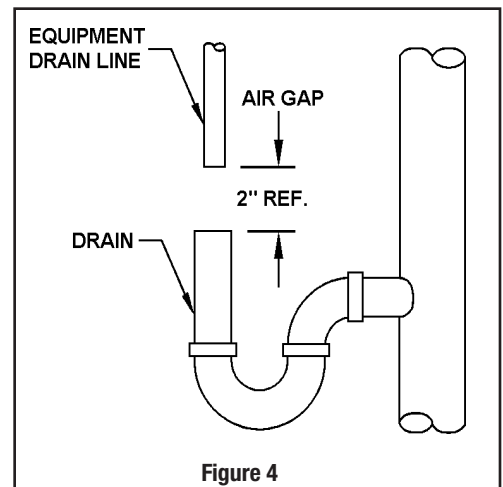

Figure 4

Step 8) Position the drain line over the drain and secure firmly. To prevent back-siphoning of sewer water, provide an air-gap of at least 2" or 2 pipe diameters between end of drain hose and drain (Figure 4). DO NOT raise drain line more than 10 ft. above floor.

Step 9) Connect one end of the included 3/8" black polyethylene tubing to the brine fitting located on the left side of the control valve. Connect the other end to the safety brine valve elbow inside of the brine well in the brine tank. To do so, remove the retaining clip from the brine line fitting on the control valve. The retaining clip is holding a plastic insert sleeve and needs to be inserted into the polyethylene tubing before installing the tubing into the fitting elbow and hand tighten only. **CAUTION: DO NOT use pliers or wrenches to tighten as damage may occur and will void the manufacturer's warranty.**

Step 10) Install the overflow line to the brine tank overflow fitting (Figure 3). The overflow discharge must be lower than the overflow fitting. DO NOT connect overflow line with valve drain line.

Step 11) Make certain the bypass valve inlet and outlet knobs are in "bypass" position. After all plumbing connections have been completed, open main water shut-off valve and restore power to well pump. Check for leaks and correct as necessary.

Step 12) Plug the control valve power cord into 110v/60Hz, non-switched power source. Program the control valve (refer to page 3-1).

NOTE: Regeneration settings for the control valve are factory preset. The control valve design permits adjustment of the salt setting. This adjustment may be necessary when unusual operating conditions exist, such as high concentrations of iron, manganese or hardness and/or high flow rates or daily water consumption.

Step 13) Manually set the control to backwash position. Press and hold the REGEN button for 3 seconds. The valve will advance to the backwash position. When in position it will begin the cycle time count down. Unplug the power cord to prevent the unit from advancing automatically.

- Step 14) Partially open the inlet knob on bypass valve (Figure 4). This will allow the unit to fill slowly from the bottom up, reducing air entrapment. Allow the unit to fill slowly, failure to do so could result in loss of resin to the drain. Once a steady stream of water, with no air sputtering, is flowing to the drain, the inlet and outlet bypass knobs can be fully opened (refer to Figure 5). Allow water to flow for 30 minutes.
- Step 15) Plug the power cord back into the power source. Press the REGEN button once and wait for the valve to advance to the REGENERATE position indicated by the timer countdown. Press the REGEN button again to advance to 2 BACKWASH indicated by the timer countdown, press the REGEN button again to advance to RINSE cycle.
- Step 16) Unplug power cord to prevent the unit from advancing automatically. Allow the water to flow to drain for 70 minutes. Plug the power cord back into the power source and allow the program to restart automatically and complete the normal program. Allow brine tank to fill with the preset amount of water. Note: brine tank will not completely fill with water. Unit is ready for service when the Time shows on the display (Time of Day will be on the display).
- Step 17) Fill brine tank with salt.
- Step 18) Refer to **Section 3: Control Valve Programming and Regeneration Instructions**, on how to set control valve for proper set up and regeneration settings.

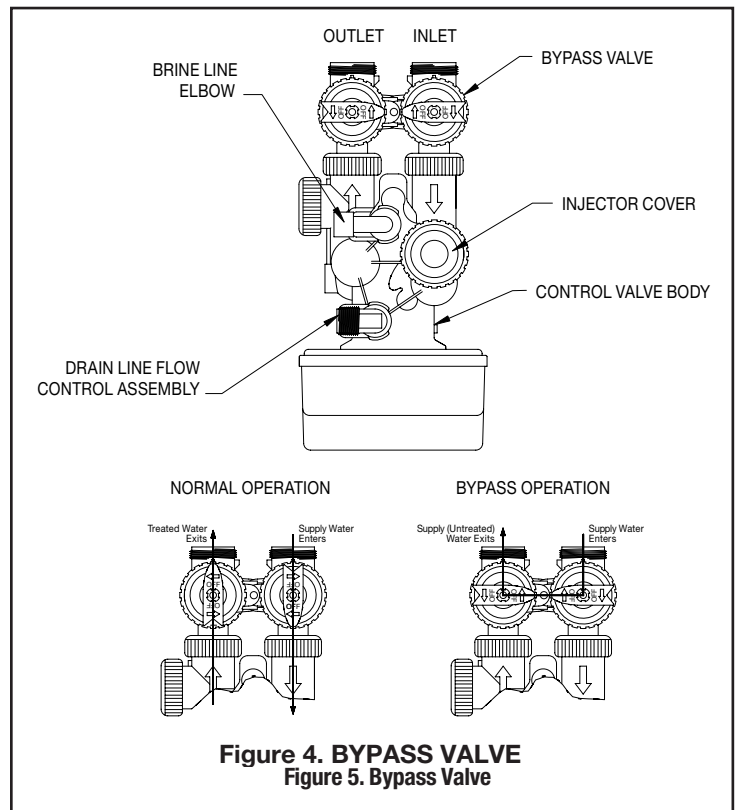

SPECIAL SERVICE INSTRUCTIONS:

Under normal circumstances removal of the valve should not be required. However, if it must be removed, disconnect the plumbing attached to the bypass valve first. Then, rotate the valve head assembly to the left or counter-clockwise. Before attempting any disassembly, pressure should be relieved by shutting off water to the system and opening a faucet. Upon reassembly, all o-rings should be lubricated with silicone grease. Reattach valve head assembly by rotating to the right or clockwise until valve head assembly is seated to the tank hand tight. Reconnect the plumbing to the bypass valve.

SECTION 3: CONTROL VALVE PROGRAMMING AND REGENERATION

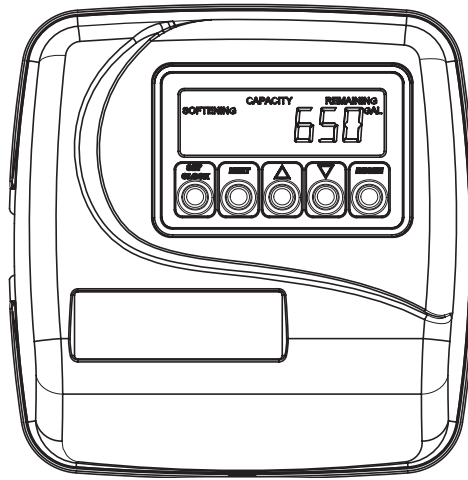

Installer Display Settings

(Step 1) Press NEXT and ▲ simultaneously for 3 seconds.

(Step 2) Hardness: Set the amount of hardness in grains of hardness as calcium carbonate per gallon using the ▼ or ▲ buttons. The default is 20 with value ranging from 1 to 150 in 1 grain increments. Note: The grains per gallon can be increased if soluble iron needs to be reduced. Press NEXT to go to Step 3. Press REGEN to exit Installer Display Settings.

(Step 3) Day Override: Day Override sets the number of days between regenerations and sets the maximum number of days between regenerations. If value is set as a number (allowable range from 1 to 28) a regeneration initiation will be called for on that day even if sufficient number of gallons were not used to call for a regeneration. Set Day Override using ▼ or ▲ buttons.

- number of days between regeneration (1 to 28); or "OFF".

Press NEXT to go to Step 4. Press REGEN to return to previous step.

(Step 4) Next Regeneration Time (hour): Set the hour of day for regeneration using ▲ or ▼ buttons. AM/PM toggles after 12. The default time is 2:00 a.m. Press NEXT to go to Step 5. Press REGEN to return to previous step.

(Step 5) Next Regeneration Time (minutes): Set the minutes of day for regeneration using ▲ or ▼ buttons. Press NEXT to exit Installer Display Settings. Press REGEN to return to previous step.

To initiate a manual regeneration immediately, press and hold the "REGEN" button for three seconds. The system will begin to regeneration immediately. The control valve may be stepped through the various regeneration cycles by pressing the "REGEN" button.

Power Lost

If a outage of eight hours or more occurs, the time of day will flash on and off which indicated the time of day should be reset. The system will remember the rest.

Error Message

If the word "error" and a number are alternately flashing on the display contact the "Technical Support Services Department" at 3M Purification Inc., phone number 1-866-990-9785 for help. This indicates that the valve was not able to function properly.



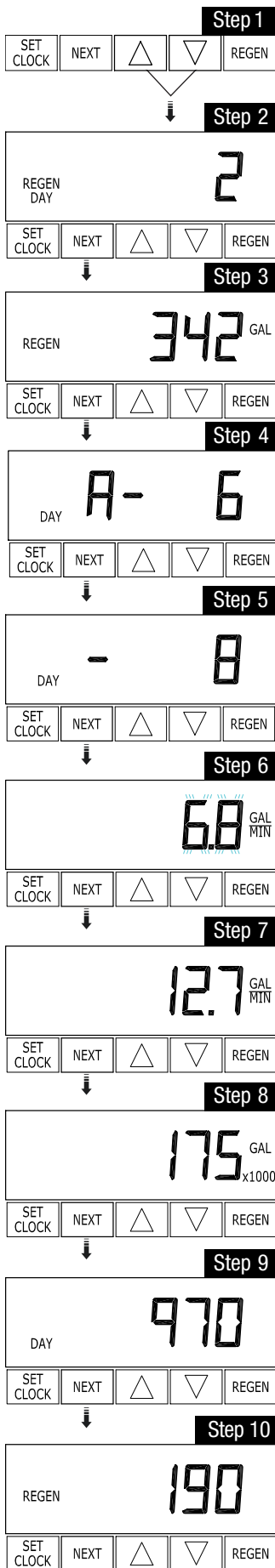

RETURN TO
NORMAL MODE

Diagnostics

(Step 1) Press ▼ or ▲ simultaneously for 3 seconds. If screen in step does not appear in 5 seconds the lock on the valve is activated. To unlock press, ▼, NEXT, ▲, and SET CLOCK in sequence, then press NEXT and ▼ simultaneously for 3 seconds.

(Step 2) Days, since last regeneration: This display shows the days since the last regeneration occurred. Press the NEXT button. Press REGEN to exit Diagnostics.

(Step 3) Gallons, since last regeneration: This display shows the number of gallons that have been treated since the last regeneration. This display will equal zero if a water meter is not installed. Press the NEXT button. Press REGEN to return to previous step.

(Step 4) Gallons, reserve capacity used for last 7 days: This display shows 0 day (for today) and flashes the reserve capacity. Pressing the ▲ button show day 1 (which would be yesterday) and flashes the reserve capacity used. Pressing the ▲ button again will show day

2 (the day before yesterday) and reserve capacity. Keep pressing the ▲ button to show the gallons for days 3, 4, 5 and 6. The ▼ button can be pressed to move backwards in the day series. Press the NEXT button at any time. Press REGEN to return to previous step.

(Step 5) Gallons, 63 day usage history: This display shows day 1 (for yesterday) and flashes the number of gallons treated yesterday. Pressing the ▲ button will show day 2 (which would be the day before yesterday) and flashes the number of gallons treated on that day. Continue to press the ▲ button to show the maximum number of gallons treated for the last 63 days. This display will show dashes if a water meter is not installed. Press the NEXT button at any time. Press REGEN to return to previous step.

(Step 6) Flow rate, current: Turn the water on at one or more taps in the building. The flow rate in gallons per minute will be displayed. If flow stops the value will fall to zero in a few seconds. This display will equal zero if a water meter is not installed. Press the NEXT button. Press REGEN to return to previous step.

(Step 7) Flow rate, maximum last seven days: The maximum flow rate in gallons per minute that occurred in the last seven days will be displayed. This display will equal zero if a water meter is not installed. Press the NEXT button. Press REGEN to return to previous step.

(Step 8) Gallons, total used since last reset: The total number of gallons used since last reset will be displayed. This display will equal zero if a water meter is not installed. Press the NEXT button. Press REGEN to return to previous step.

(Step 9) Days, total number since last reset: The total number of days the control valve has been in service since last reset will be displayed. Press the NEXT button. Press REGEN to return to previous step.

(Step 10) Regenerations, total number since last reset: The total number of regenerations that have occurred since last reset will be displayed. Press the NEXT button to exit Diagnostics. Press REGEN to return to previous step. To lock settings press ▼, NEXT, ▲, and SET CLOCK in sequence.



Valve History

(Step 1) Press ▲ or ▼ simultaneously for 3 seconds and release. Then press ▲ and ▼ simultaneously and release. If screen, to the left, does not appear is 5 seconds the lock on the valve is activated. To unlock press ▼, NEXT, ▲ and SET CLOCK in sequence, then press ▲ and ▼. Then press ▲ and ▼ simultaneously and release.

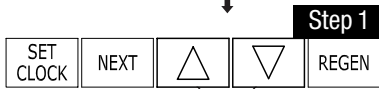

(Step 2) Software Version: This display shows the software version of the valve. Press the NEXT button to go to the next step or press REGEN to exit Valve History.



(Step 3) Flow rate, maximum since startup: This display shows the maximum flow rate in gallons per minute that has occurred since startup. This display will equal zero if a water meter is not functioning. Press the NEXT button to go to the next step. Press REGEN to return to previous step.



(Step 4) Gallons, total used since start-up: This display shows the total gallons. This display shows the total days since start-up. Press the NEXT button to go to the next step. Press REGEN to return to previous step.

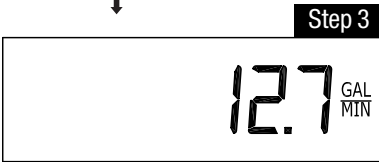

(Step 5) Days, total since start-up: This display shows the total days since start-up. Press the NEXT button to go to the next step. Press REGEN to return to previous step.



(Step 6) Regenerations, total number since start-up: This display shows the total number of regenerations that have occurred since start-up. Press the NEXT button to go to the next step. Press REGEN to return previous step.



(Step 7) Error, number of occurrences since start-up: This display shows E and the total number of errors that have occurred since start-up. Press the NEXT button to exit Valve History. Press REGEN to return to previous step. To lock settings press ▲, NEXT, ▼ and SET CLOCK in sequence.

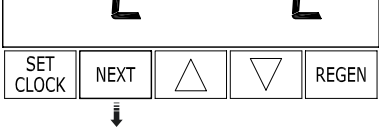
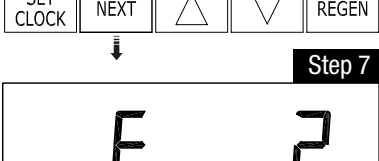
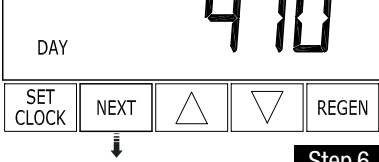
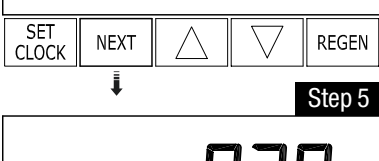

RETURN TO
NORMAL MODE

User Display Settings

General Operation

When the system is operating, one of two displays will be shown. Pressing NEXT will alternate between the displays. One of the displays is always the current time of day. The second display is one of the following: days remaining or gallons remaining. Days remaining is the number of days left before the system goes through a regeneration cycle. Capacity remaining is the number of gallons that will be treated before the system goes through a regeneration cycle. The user can scroll between the displays as desired.

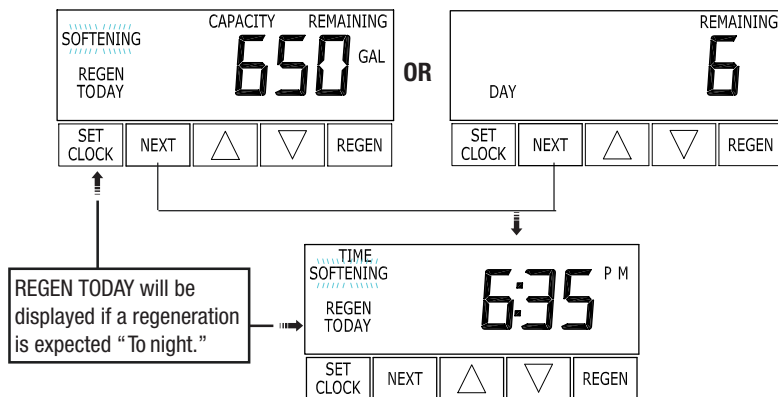

If the system has called for a regeneration that will occur at the preset time of regeneration, the words “REGEN TODAY” will appear on the display.

When water is being treated (i.e. water is flowing through the system) the word “SOFTENING” flashes on the display if a water meter is installed.

Regeneration Mode

Typically a system is set to regenerate at a time of low water usage. An example of a time with low water usage is when members of a household are asleep. If there is a demand for water when the system is regenerating, untreated water will be used.



When the system begins to regenerate, the display will change to include information about the step of the regeneration process and the time remaining for that step to be completed. The system runs through the steps automatically and will reset itself to help provide treated water when the regeneration has been completed.

Manual Regeneration

Sometimes there is a need to regenerate the system sooner than when the system calls for it, usually referred to as manual regeneration. There may be a period of heavy water usage because of guests or a heavy laundry day.

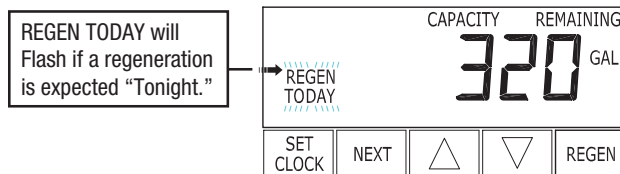

To initiate a manual regeneration at the present delayed regeneration time, press and release “REGEN”. The words “REGEN TODAY” will flash on the display to indicate that the system will regenerate at the preset delayed regeneration time.

NOTE: If you pressed the “REGEN” button in error, pressing the button again will cancel the request.

To initiate a manual regeneration immediately, press and hold the “REGEN” button for 3 seconds. The system will begin to regenerate immediately. The request cannot be cancelled.

NOTE: For water softeners, if brine tank does not contain salt, fill with salt and wait at least two hours before regenerating.

Set Time of Day

The user can also set the time of day. Time should only need to be set after extended power outages or when daylight saving time begins or ends. If an extended power outage occurs or when daylight saving time begins or ends, the time of day will flash on and off which indicates the time of day should be reset.

Step 1 - Press SET CLOCK.

Step 2 - Current Time (hour): Set the hour of the day using ▲ or ▼ button. AM/PM toggles after 12. Press NEXT to go to Step 3.

Step 3 - Current Time (minutes): Set the minutes of the day using ▲ or ▼ buttons. Press NEXT to exit Set Clock. Press “REGEN” to return to previous step.

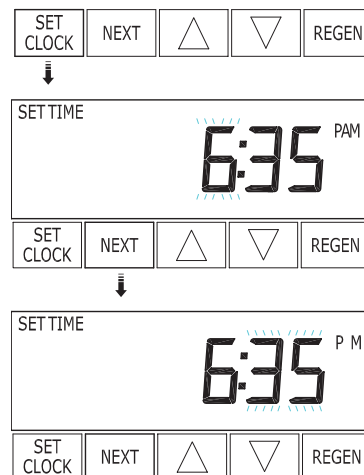

SECTION 4: MAINTENANCE

Replenishment of Salt Supply:

The salt storage capacity of the brine tank is approximately 135 lbs. (61 kg). During each regeneration a specific amount of salt is consumed, thus requiring its periodic replenishment for a continuous supply of softened water. The frequency and salt dosage level is dependent on the regeneration schedule. Always replenish salt before the supply is exhausted.

Type of Salt to Use:

Most types of water softener salt may be used. There are advantages and disadvantages to every type of salt. Please ask your local dealer for advice. 3M Purification does not recommend the use of block type salt.

Brine Tank Clean-Out:

To help prevent service problems the brine tank should be emptied and flushed out with a garden hose annually or when dirt and other insolubles accumulate. The clean-out should be done when the salt level is low. Do not perform this clean-out procedure during regeneration cycle.

Steps to follow:

- (1) Disconnect brine line at either end.
- (2) Turn brine tank upside down and discard old salt.
- (3) Remove the salt shelf and rinse both the tank and salt shelf with a garden hose.
- (4) Reinstall salt shelf and reconnect brine line.
- (5) Before loading salt, using a pail or garden hose, add enough water to the brine tank to cover the lower portion of the salt shelf. Then add salt to brine tank. Add one (1) cup of unscented laundry bleach to the brine well to sanitize the system.

Iron-Fouling of Media Bed:

If iron is present in the water supply, the water softener media bed will eventually become iron-fouled, resulting in reduced softening capacity and rust-stained fixtures. Mixing one to two ounces of Iron Reduction Media with every 80 lbs (36 kg). of salt added to brine tank will help minimize these problems from occurring. Please contact your Dealer/Installer or our Customer Service Department at 1-866-990-9785 for additional information.

Periodically Check Time of Day Setting:

Power outages of eight hours or more will cause "TIME OF DAY" setting to become incorrect. To correct, refer to **Section 3**.

Malfunction of Unit:

Your water softener, under normal conditions, should provide years of virtually trouble-free service; however, since it is a mechanical device, it can malfunction. (Please refer to our Troubleshooting Guide under **Section 6, page 6-1 for additional information**).

Change of Operating Conditions:

Should your water usage habits or your water quality change, the regeneration program settings may have to be adjusted. Please contact your Dealer/Installer or our Customer Service Department at 1-866-990-9785 for additional information.

Special Service Instructions:

Under normal circumstances removal of the valve should not be required. However, if it must be removed, disconnect the plumbing attached to the bypass valve first. Then, rotate the valve head assembly to the left or counter-clockwise. Before attempting any disassembly, pressure should be relieved by shutting off water to the system and opening a faucet. Upon reassembly, all o-rings should be lubricated with silicone grease. Reattach valve head assembly by rotating to the right or clockwise until valve head assembly is seated to the tank hand tight. Reconnect the plumbing to the bypass valve.

SECTION 5: CONTROL VALVE TROUBLESHOOTING GUIDE

Problem	Possible Cause	Solution
1. Timer does not display time of day	A. AC Adapter unplugged	A. Connect power
	B. No electric power at outlet	B. Repair outlet or use working outlet
	C. Damaged AC Adapter	C. Replace AC Adapter
	D. Damaged PC board	D. Replace PC board
2. Timer does not display correct time of day	A. Switched outlet	A. Use uninterrupted outlet
	B. Power outage	B. Reset time of day
	C. Damaged PC board	C. Replace PC board
3. No softening/filtering display when water is flowing	A. Bypass valve in bypass position	A. Put bypass valve in service position
	B. Meter connection disconnected	B. Connect meter to PC board
	C. Restricted/stalled meter turbine	C. Remove meter and check for rotation or foreign material
	D. Damaged meter	D. Replace meter
	E. Damaged PC board	E. Replace PC board
	F. Meter wire not securely installed into connector.	F. Verify meter wire installed securely into three pin connector labeled METER.
4. Control Valve regenerates at wrong time of day	A. Power outages	A. Reset control valve to correct time of day
	B. Time of day not set correctly	B. Reset to correct time of day
	C. Time of regeneration incorrect	C. Reset regeneration time
	D. Control valve set at "ON" (which initiates an immediate regeneration).	D. Check program setting and reset to NORMAL (for a delayed regeneration time).
	E. Control valve set at "NORMAL + on 0" (delayed and/or immediate).	E. Check program setting and reset to NORMAL (for a delayed regeneration time).
5. ERROR followed by code number Error Code 1001 - Unable to recognize start of regeneration Error Code 1002 - Unexpected stall Error Code 1003 - Motor ran too long, timed out trying to reach next cycle position Error Code 1004 - Motor ran too long, timed out trying to reach home position If other Error Codes display, contact the factory	A. Control valve has just been serviced or unplug power source jack (black wire) and plug back in to reset control valve.	A. Press NEXT and REGEN for 3 seconds
	B. Foreign matter is lodged in control valve	B. Check piston and spacer stack assembly
	C. High drive forces on piston	C. Replace piston(s) and spacer stack assembly
	D. Control valve piston not in home position seconds	D. Press NEXT and REGEN for 3 seconds or unplug power source jack (black wire) and plug back in to reset control valve
	E. Motor not inserted fully to engage pinion, motor wires broken or disconnected, motor damaged	E. Check motor and wiring. Replace motor if necessary
	F. Drive gear label dirty or damaged, missing or broken gear	F. Replace or clean drive gear
	G. Drive bracket incorrectly aligned to back plate	G. Reseat drive bracket properly
	H. PC board is damaged	H. Replace PC board
	I. PC board incorrectly aligned to drive bracket	I. Ensure PC board is correctly snapped on to drive bracket
6. Control valve stalled in regeneration	A. Motor not operating	A. Replace motor
	B. No electric power at outlet	B. Repair outlet or use working outlet
	C. Damaged AC Adapter	C. Replace AC Adapter
	D. Damaged PC board	D. Replace PC board
	E. Broken drive gear or drive cap assembly	E. Replace drive gear or drive cap assembly
	F. Broken piston retainer	F. Replace drive cap assembly
	G. Broken main or regenerant piston	G. Replace main or regenerant piston
7. Control valve does not regenerate automatically when "REGEN" button is depressed and held	A. AC Adapter unplugged	A. Connect AC Adapter
	B. No electric power at outlet	B. Repair outlet or use working outlet
	C. Broken drive gear or drive cap assembly	C. Replace drive gear or drive cap assembly
	D. Damaged PC board	D. Replace PC board
8. Control valve does not regenerate automatically but does when "REGEN" button is depressed	A. Bypass valve in bypass position	A. Put bypass valve in normal operating position
	B. Meter connection disconnected	B. Connect meter to PC board
	C. Restricted/stalled meter turbine	C. Remove meter and check for rotation or foreign matter
	D. Damaged meter	D. Replace meter
	E. Damaged PC board	E. Replace PC board
	F. Set-up error	F. Check control valve set-up procedure
	G. Meter wire not security installed into connector.	G. Verify meter wire installed securely into three pin connector labeled METER.

9. Time of day flashes on and off	A. Power has been out more than eight hours, the AC Adapter was unplugged and then plugged back into the wall outlet, the AC Adapter plug was unplugged and then plugged back into the board or the NEXT and REGEN buttons were pressed to reset the valve	A. Reset the time of day
-----------------------------------	--	--------------------------

SECTION 5: CONTROL VALVE SERVICE INSTRUCTIONS

Drive Assembly:

Remove the valve cover to access the drive assembly.

IMPORTANT NOTE: Disconnect the power source plug (black wire) from the PC board prior to disconnecting the motor or water meter plugs from the PC board. The power source plug connects to the four-pin jack. The motor plug connects to the two-pin jack on the left-hand side of the PC board. The water meter plug (grey wire) connects to the three-pin jack on the far right-hand side of the PC board.

The PC board can be removed separately from the drive bracket but it is not recommended. Do not attempt to remove the display panel from the PC board. Handle the board by the edges. To remove the PC board from the drive bracket, unplug the power, water meter and motor plugs from the PC board. Lift the middle latch along the top of the drive bracket while pulling outward on the top of the PC board. The drive bracket has two plastic pins that fit into the holes on the lower edges of the PC board. Once the PC board is tilted about 45° from the drive bracket it can be lifted off of these pins. To reinstall the PC board, position the lower edge of the PC board so that the holes in the PC board line up with the plastic pins. Push the top of the PC board towards the valve until it snaps under the middle latch, weave the power and water meter wires into the holders and reconnect the motor, water meter and power plugs.

The drive bracket must be removed to access the drive cap assembly and pistons or the drive cap gear cover. It is not necessary to remove the PC board from the drive bracket to remove the drive bracket. To remove the drive bracket, start by removing the plugs for the power source and the water meter. Unweave the wires from the side holders. Two tabs on the top of the drive back plate hold the drive bracket in place. Simultaneously lift the two tabs and gently ease the top of the drive bracket forward. The lower edge of the drive bracket has two notches that rest on the back plate. Lift up and outward on the drive bracket to disengage the notches.

To reassemble, seat the bottom of the drive bracket so the notches are engaged at the bottom of the drive back plate. Push the top of the drive bracket toward the two latches. The drive bracket may have to be lifted slightly to let the threaded piston rod pass through the hole in the drive bracket. Maintain a slight engaging force on top of the drive bracket while deflecting the bracket slightly to the left by pressing on the side of the upper right corner. This helps the drive gears mesh with the drive cap assembly. The drive bracket is properly seated when it snaps under the latches on the drive back plate. If resistance is felt before latching, then notches are not fully engaged, the piston rod is not in the hole, the wires are jammed between the drive bracket and drive back plate, or the gear is not engaging the drive cap assembly. To inspect the drive gears, the drive gear cover needs to be removed. Before trying to remove the gear cover, the drive bracket must be removed from the drive back plate. (Refer to the proceeding instructions regarding removing the drive bracket from the drive back plate. The drive gear cover can be removed from the drive bracket without removing the motor or the PC board.) The drive gear cover is held in place on the drive bracket by three clips. The largest of the three clips is always orientated to the bottom of the drive bracket. With the PC board facing up, push in and down on the large clip on the drive gear cover. Handle the cover and the gears carefully so that the gears do not fall off of the pegs in the cover.

Replace broken or damaged drive gears. Do not lubricate any of the gears. Avoid getting any foreign matter on the reflective coating because dirt or oils may interfere with pulse counting.

The drive gear cover only fits on one way, with the large clip orientated towards the bottom. If all three clips are outside of the gear shroud on the drive bracket and the drive gear cover slips easily into place.

The drive bracket does not need to be removed from the drive plate if the motor needs to be removed. To remove the motor, disconnect the power and motor plugs from the jacks on the PC board. Move the spring clip loop to the right and hold. Rotate the motor at least a 1/4 turn in either direction so the wires are vertical (up & down) before gently pulling on the wire connectors to remove the motor. Pulling directly on the wires without rotating the motor may break the wires off the motor.

Replace the motor if necessary. Do not lubricate the motor or the gears. To reinstall the motor, move the spring clip loop to the right and hold. Gently turn the motor while inserting so that the gear on the motor meshes with the gears under the drive gear cover. Release the spring clip loop and continue to rotate the motor until the wires are horizontal and the motor housing engages the small plastic bulge inside the drive bracket motor retainer. Reconnect the motor plug to the two-pronged jack on the lower left hand side of the PC board. If the motor will not easily engage with the drive gears when reinstalling, lift and slightly rotate the motor before reinserting. Reconnect the power.

Replace the valve cover. After completing any valve maintenance, press and hold NEXT and REGEN buttons for 3 seconds or unplug power source jack (black wire) and plug back in. This resets the electronics and establishes the service piston position. The display should flash all wording, then flash the software version (e.g. 181) and then reset the valve to the service position.

Drive Cap Assembly, Main Piston and Regenerant Piston:

The drive assembly must be removed to access the drive cap assembly. The drive cap assembly must be removed access the piston(s). The drive cap assembly is threaded into the control valve body and seals with an o-ring. To remove the drive cap assembly use the special plastic wrench or insert a 1/4" to 1/2" flat blade screwdriver into one of the slots around the top 2" of the drive cap assembly so it engages the notches molded into the drive back plate around 2" or the piston cavity. See Figure 6 on page 5-3. The notches are visible through the holes. Lever the screwdriver so the drive cap assembly turns to the left. Once loosened, unscrew the drive cap assembly by hand and pull straight out. The drive cap assembly contains the drive cap, the main drive gear, drive cap spline, piston rod and various other parts that should not be dissembled in the field. The only replaceable part on the drive cap assembly is the o-ring. Attached to the drive cap assembly is the main piston and a regenerant piston.

The regenerant piston (the small diameter one behind the main piston) is removed from the main piston by pressing sideways and unsnapping it from its latch. Chemically clean in dilute sodium bisulfate or vinegar, or replace the regenerant piston if needed. To remove the main piston fully extend the piston rod and then unsnap the main piston from its latch by pressing on the side with the number. Chemically clean in dilute sodium bisulfite or vinegar, or replace the main piston.

Reattach the main piston to the drive cap assembly. Reattach the regenerant piston (if needed) to the main piston. Do not lubricate the piston rod, main piston or regenerant piston. Lubricant will adversely affect the clear lip seals. Reinsert the drive cap assembly and piston into the spacer stack assembly and hand tighten the drive cap assembly. Continue to tighten the drive cap assembly using a screwdriver as a ratchet until the black o-ring on the spacer stack assembly is no longer visible through the drain port. Excessive force can break the notches molded into the drive back plate. Make certain that the main drive gear still turns freely.

The exact position is not important as long as the main drive gear turns freely. Reattach the drive assembly to the control valve and connect all plugs. After completing any valve maintenance, press and hold NEXT and REGEN buttons for 3 seconds or unplug power source jack (black wire) and plug back in. This resets the electronics and establishes the service piston position. The display should flash all wording, then flash the software version (e.g. 181) and then reset the valve to the service position.

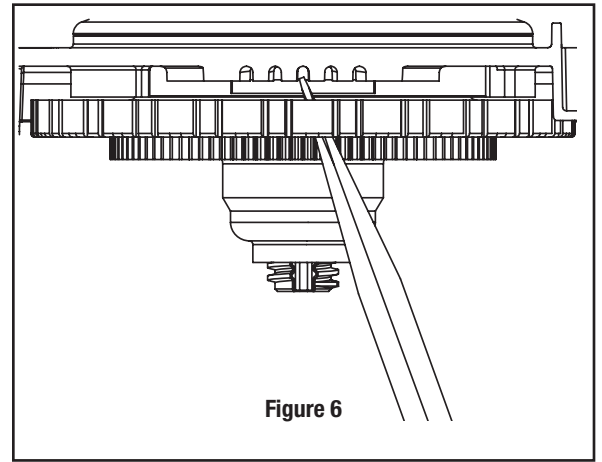

Spacer Stack Assembly:

To access the spacer stack assembly remove the drive assembly, drive cap assembly and piston. The spacer stack assembly can be removed easily without tools by using thumb and forefinger. Inspect the black o-rings and clear lip seals for wear or damage. Replace the entire stack if necessary. Do not disassemble.

The spacer stack assembly may be chemically cleaned (dilute sodium bisulfite or vinegar) or wiped with a soft cloth.

The spacer stack assembly can be pushed into the control valve body bore by hand. Since the spacer stack assembly can be compressed it is easier to use a blunt object (5/8" to 1-1/8" in diameter) to push the center of the assembly into the control valve body. The assembly is properly seated with at least four threads exposed (approximately 5/8"). Do not force the spacer stack assembly in. The control valve body bore interior can be lubricated with silicone to allow for easy insertion of the entire stack. Do not use silicone or any other type of lubricant on the clear lip seals of the piston.

Reattach the drive cap assembly and piston(s) and the drive assembly.

After completing any valve maintenance, press and hold NEXT and REGEN buttons for 3 seconds or unplug power source jack (black wire) and plug back in. This resets the electronics and establishes the service piston position. The display should flash all wording, then flash the software version (e.g. 181) and then reset the valve to the service position.

Injector Cap, Screen, Injector Plug and Injector:

Unscrew the injector cap and lift off. Loosen cap with special plastic wrench or pliers if necessary. Attached to the injector cap is a screen. Remove the screen and clean if fouled. The plug and/or injector can be pried out with a small screwdriver. The plug can be wiped clean. If the plug leaks replace the entire plug. The injector consists of a throat and a nozzle. Chemically clean the injector with vinegar or sodium bisulfite. The holes can be blown out with air. Both pieces have a small diameter holes that control the flow rates of water so that the proper concentration of regenerant is used. Sharp objects, which can score the plastic, should not be used to clean the injector. Scoring the injector or increasing the diameter of the hole could change the operating parameters of the injector. Push the plug(s) and/or injectors firmly in place, replace the screen and hand tighten the injector cap.

Refill Flow Control Assembly or Refill Port Plug:

To clean or replace the refill flow control, pull out the elbow-locking clip and then pull straight up on the elbow. Replace the elbow locking clip in the slot so that it is not misplaced. Twist to remove the white flow control retainer. The flow control can be removed by prying upward through the side slots of the retainer with a small flat blade screwdriver.

Chemically clean the flow control or the white flow control retainer using dilute sodium bisulfite or vinegar. Do not use a wire brush. If necessary, replace the flow control, o-ring on the flow control retainer, or the o-ring on the elbow.

Reseat the flow control so the rounded end is visible in the flow control. Reseat the white flow control retainer by pushing the retainer into the elbow until the o-ring seats. Remove locking clip, push down on elbow to reseat and insert locking clip. Do not use petroleum jelly, oils, or other unacceptable lubricants on o-rings. A silicone lubricant may be used on the o-ring on the elbow or the white retainer.

Water Meter or Meter Plug:

The water meter assembly is connected to the PC board by a wire. If the entire water meter assembly is to be replaced, remove the control valve cover and disconnect the power source and water meter plugs from the PC board. Unlatch the drive assembly and lean it forward. Unthread the water meter wire from the side of the drive assembly and through the drive back plate. To reinstall, rethread the water meter wire through the drive back plate and the side of the drive assembly. Reattach the drive assembly and the water meter and power plugs. If no water meter wire is visible, then a plug is installed, not a water meter. The water meter wire does not need to be removed from the PC board if the water meter is only being inspected and cleaned. To remove the water meter assembly, unscrew the meter cap on the left side of the control valve. Pliers may be used to unscrew the nut if necessary. With the nut removed, a slot at the top of the water meter is visible. Twist a flat blade screwdriver in the slot between the control valve body and the meter. When the meter is part way out it is easy to remove the water meter from the housing. Once the water meter is removed from the control valve body, gently pull forward on the turbine to remove it from the shaft.

Do not use a wire brush to clean the turbine. Wipe with a clean cloth or chemically clean in dilute sodium bisulfite or vinegar. The turbine can be immersed in the chemical. Do not immerse electronics. If the turbine is scored or damaged or the bearing on the turbine are worn, replace the turbine.

Do not lubricate the turbine shaft. The turbine shaft bearings are prelubricated. Do not use petroleum jelly, oils, or other unacceptable lubricants on the o-ring. A silicone lubricant may be used on the black o-ring.

Snap the turbine on the shaft and reinsert the water meter into the side slot. Hand tighten the nut. Do not use a pipe wrench to tighten nut.

Bypass Valve:

The working parts of the bypass valve are the rotor assemblies that are contained under the bypass valve caps. Before working on the rotors, make sure the system is depressurized. Turn the red arrow shaped handles towards the center of the bypass valve and back several times to ensure rotor is turning freely.

The nuts and caps are designed to be unscrewed or tightened by hand. If necessary a pliers can be used to unscrew the nut or cap. Do not use a pipe wrench to tighten or loosen nuts or caps. Do not place screwdriver in slots on caps and/or tap with a hammer. To access the rotor, unscrew the cap and lift the cap, rotor and handle out as one unit. Twisting the unit as you pull it out will help to remove it more easily. There are three o-rings: one under the rotor cap, one on the rotor stem and the rotor seal. Replace worn o-rings. Clean rotor. Reinstall rotor.

When reinstalling the red arrow handles be sure that:

1. The handle pointers are lined up with the control valve body arrows, and the rotor seal o-ring and the retainer on both rotors face to the right when being viewed from the front of the control valve; or
2. Arrows point toward each other in the bypass position.

Since the handles can be pulled off, they could be accidentally reinstalled 180° from their correct orientation. To install the red arrow handles correctly, keep the handles pointed in the same direction as the arrows engraved on the control valve body while tightening the bypass valve caps. After completing and valve maintenance, press and hold NEXT and REGEN buttons for 3 seconds or unplug power source jack (black wire) and plug back in. This resets the electronics and establishes the service piston position. The display should flash all wording, then flash the software version (e.g. 181) and then reset the valve to the service position.

SECTION 6: SYSTEM TROUBLESHOOTING GUIDE

Problem	Possible Cause	Solution
1. Hard water (unit not using salt; liquid level in brine tank not too high)	A. Electrical service to unit interrupted	A. Assure permanent electrical service is working properly (check fuse, plug, pull chain, or switch)
	B. Timer not working.	B. Replace timer assembly.
	C. Timer improperly set	C. Check programming function
	D. Safety brine valve not opening	D. Replace safety brine valve
	E. Salt "bridged" in brine tank	E. Breakup salt
	F. Meter not functioning	F. Clean or replace as necessary
2. Hard water (unit using salt; liquid level in brine tank not too high)	A. Bypass open	A. Close bypass (replace if necessary)
	B. Timer improperly set	B. Increase frequency of regeneration
	C. No salt in brine tank	C. Add salt; maintain above water level
	D. Excessive water usage	D. Increase frequency of regeneration and/or salt setting (See HOW TO SET TIME OF DAY)
	E. Unit installed backwards	E. Reinstall unit
	F. Unit undersized	F. Replace with larger unit
3. Liquid level in brine tank too high	A. Brine valve not closing	A. Replace brine valve
	B. Salt setting too high	B. Reset timer
	C. Injector or Injector screen plugged	C. Clean injector and screen
	D. Drain line frozen, plugged or restricted	D. Free drain
	E. Salt "mushed" or sand from salt plugging bottom of brine tank	E. Clean out brine tank (see instructions on page 4-1)
	F. Incorrect brine line flow control (BLFC)	F. Replace with correct flow control valve (see component part list on page 9-1)
4. System regenerates at wrong time of day	A. Timer improperly set	A. Reset timer
5. Water continuously flows to drain	A. Foreign material in control valve	A. Remove piston assembly and inspect bore: remove foreign material and check control in various regeneration positions
	B. Internal control leak	B. Replace seals and/or piston assembly
	C. Control valve jammed in brine or backwash position	C. Replace piston, seals and spacers
6. Water tastes salty	A. Salt setting too high	A. Reset program cycle
	B. Distributor tube too short	B. Replace
7. White spots on glassware and dark surfaces	A. Sodium residual resulting from water having very high hardness or total dissolved solids (TDS)	A. Installation of additional water treatment equipment such as reverse osmosis or demineralization
8. Low water pressure (low flow rate)	A. Iron build-up in line to water softener	A. Clean line to water softener
	B. Iron build-up in water softener	B. Clean control and add Iron Reduction Media to resin bed: increase frequency of regeneration
	C. Well pumping sand	C. Install sand trap
	D. Pump losing capacity	D. Contact pump repair service
9. "Rotten egg" smell (from hot water only)	A. Magnesium rod in water heater	A. Replace with aluminum rod or remove
10. "Rotten egg" smell (from both hot and cold water)	A. Hydrogen sulfide ("sulfur") in water supply	A. Install CSX Sulfur Reduction System
	B. Bacterial iron in water supply	B. Install APIF or APPM Iron Reduction System
	C. Algae in water supply	C. Pour approximately 1/2 cup unscented laundry bleach into brine well just before regeneration as frequently as necessary
11. Loss of resin through drain	A. Air in water system	A. Assure that well system has proper air eliminator control: check for dry well condition

SECTION 7: SPECIFICATIONS AND OPERATING DATA

ITEM	CFSM1254
Nominal Media Volume, Ft ³	2.5
Salt Dosage, Lbs.	
Factory Setting	24
Softening Capacity, grains	
At Factory Salt Setting	56,800
Flow Rate At 15 psi Pressure Loss	11
Pressure Loss, psi At Service Flow	12
Regeneration Flow Rates, gpm	
Backwash	3.2
Brine Draw @ 50 psi	0.56
Slow Rinse @ 50 psi	3.2
Rapid Rinse	3.2
Brine Refill	0.5
Approximate Water Used (at Factory Setting)	140
Regeneration Duration, minutes (at Factory Setting)	
Backwash	8
Brine Draw/Rinse	60
Rapid Rinse	10
Brine Refill	10
Approximate Total Time	88
Inlet/Outlet Size	1" NPT
Media tank Dia. x Ht., in.	12 x 52
Overall D & H w/Valve, in.	
Width (Including Brine Tank)	58
Depth	17
Height (Including Valve)	63
Brine Tank, W x D x H, in.	15 x 15 x 34
Brine Tank Capacity	
With Salt Grid Leg Extensions (required on salt settings above 18 #)	135
Approximate Shipping Wt.	188
Maximum Operating Temperature	110°F (43.3°C)
Minimum Operating Temperature	34°F (1°C)
Operating Pressure	20-125 psi (138-862 kPa)
Electrical Requirements	110/120V, 60Hz

The CFSM1254 softener conforms to NSF/ANSI Standard 44 for specific performance claims. Actual capacity may vary substantially depending on water analysis and operating conditions.

NOTES: For satisfactory performance, indicated flow rates and duration should not be exceeded. Do not use Service Flow Rate if treated water is to supply a geothermal heat pump, utility water or water sprinklers. (contact your Dealer/Installer or our Customer Service Department at 866.990.9785 before selecting equipment). Service flow rates have been tested against NSF Standard 44.

SECTION 8: PARTS COMPONENT PARTS LIST

REF	DESCRIPTION	CFSM1254
1	Control Valve	W12M320-5B3-0M
1a	O-ring	V3180
1b	Basket	D1203
2	Bypass	V3006
3	Media Tank w. Base (Incl. Ref 9)	6236001-1252
4	Distributor Tube Assembly	6236234
5	Media	H-050P (x 5)
6	Brine Line Tubing	13000X
7	Brine Tank Complete	BT1534X-EXT-DLS
8	Overflow Fitting	BT16
9	Brine tank Shell, Black	BT1534
10	Brine Well w / Cap	BT15BW
11	Grid Plate wit Extension Kit	BT15GP-EXT
12	Safety Brine Valve, Complete	BT15SBVA
13	Safety Brine Valve	60014
14	Float Assembly	60068X
15	Air Check	60002-27.5

NOTE: When ordering replacement or repair components always specify by the unit or model number to ensure correct parts delivered.

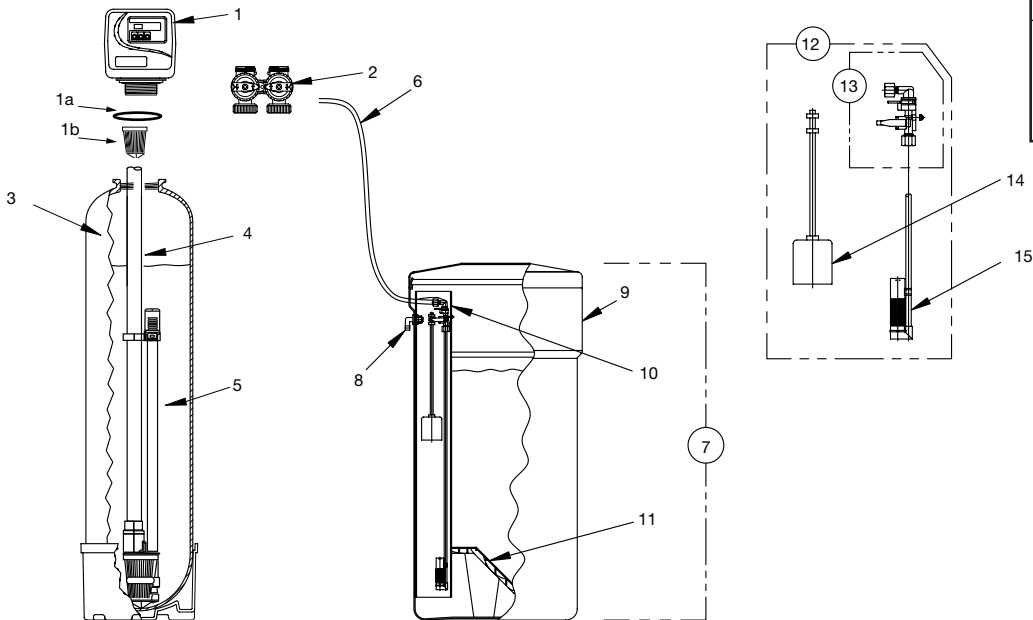

Items Not Shown	
Description of Item	Part Number
Wrench	V3193-01
Universal Elbow	V3191-01
Retaining Clip	H4615
Drain Line Insert	PKP10TS8-BULK
Drain Line Elbow Nut	V3192
Drain Line Elbow	3158-01
Plumbing Adapter Kits	
1" Brass Sweat	V3007-02
1" Plastic Male NPT	V3007-04
1.25" Plastic Male NPT	V3007-05
1" Plastic Male BSP	V3007-06

SECTION 8: PARTS (Continued)

COMPONENT PARTS LIST

Front Cover and Drive Assembly

Drawing No.	Order No.	Description	Quantity
1	V1375-01	WS1 Front Cover	1
2	V3107-01	WS1 Motor	1
3	V3106-01	WS-1 Drive Bracket & Spring Clip	1
4	V3108	WS1 PC Board	1
	V3002	WS1 Drive Assy*	1
Not Shown	V3168	WS1 AS Adapter 110V-12 V	1
Not Shown	V3168-01	WS1 AC Adapter Cord Only	1

* Drawing number parts 2 through 6 may be purchased as a complete assembly, part V3002.

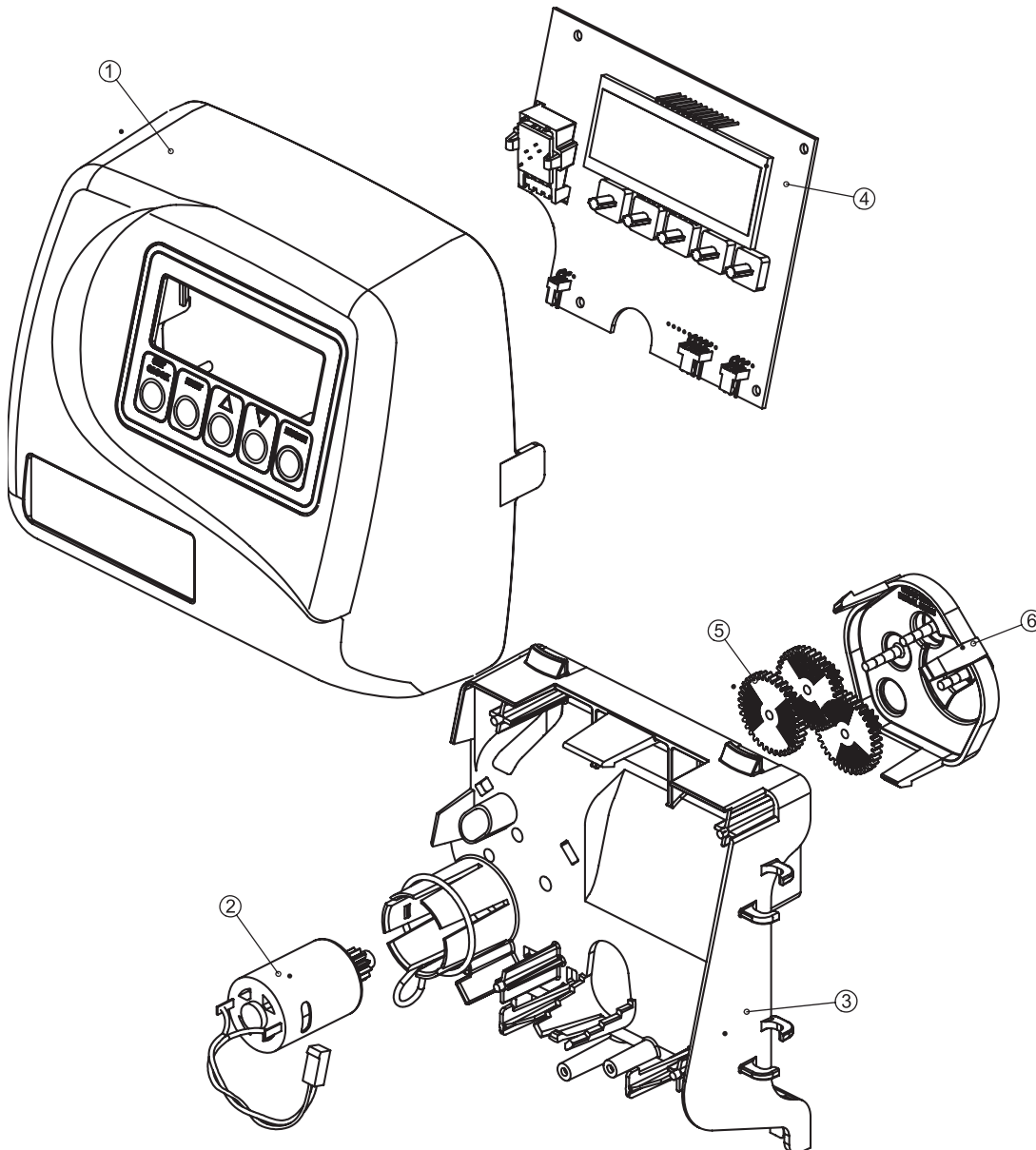

SECTION 8: PARTS (Continued)

COMPONENT PARTS LIST

Drive Cap Assembly, Downflow Piston, Regenerant Piston and Spacer Stack Assembly

Drawing No.	Order No.	Description	Quantity
1	V3005	Spacer Stack Assembly	1
2	V3004	Drive Cap Assembly	1
3	V3178	Drive Back Plate	1
4	V3011	Piston Down Flow Assembly	1
5	V3174	Regenerant Piston	1
6	V3135	O-ring 228	1
7	V3180	O-ring 337	1
8	V3105	O-ring 215 (Distributor Tube)	1
Not Shown	V3001	Body Assembly	1

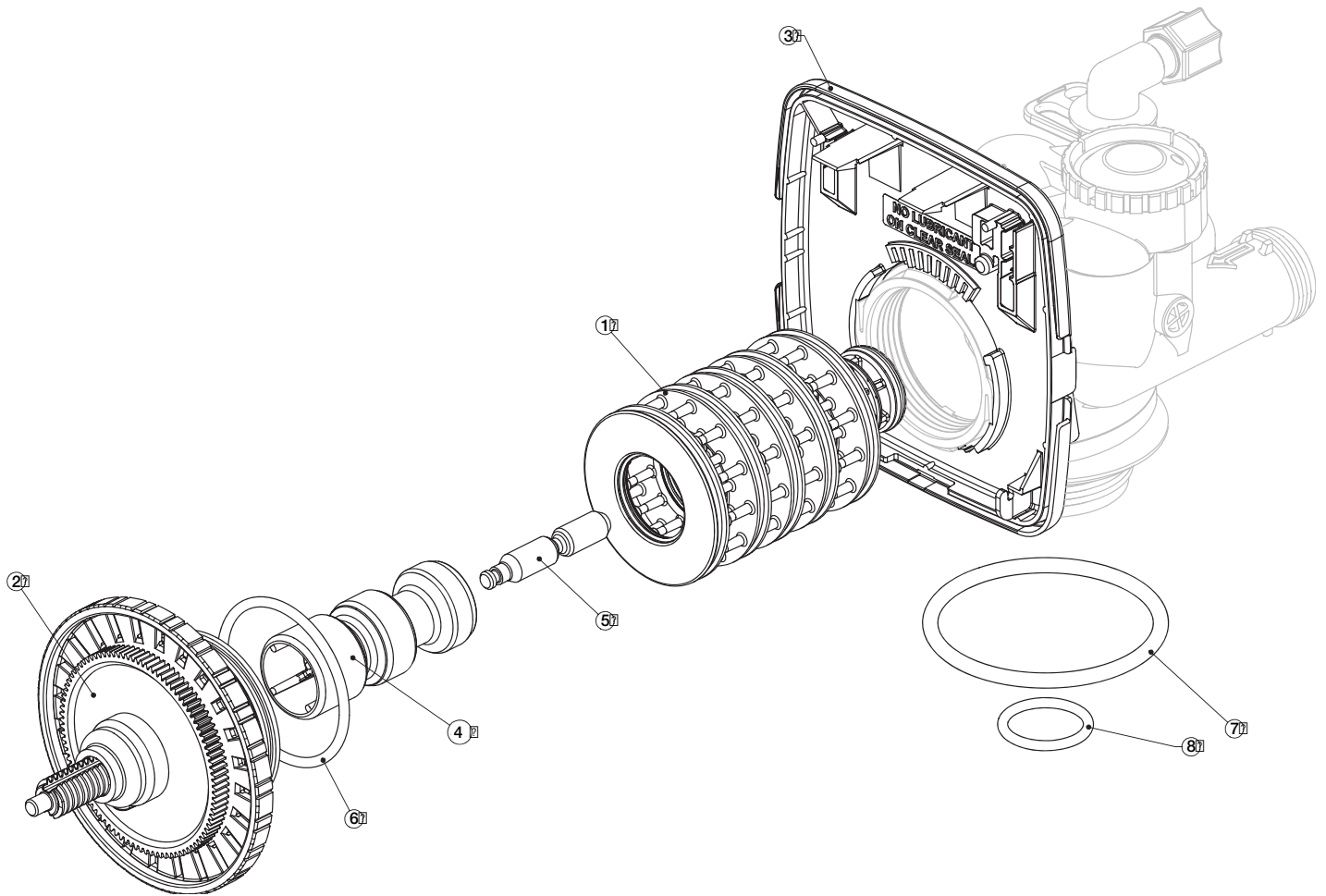

SECTION 8: PARTS (Continued) COMPONENT PARTS LIST

Injector Cap, Injector Screen, Injector, Plug and O-Ring

Drawing No.	Order No.	Description	Quantity
1	V3176	Injector Cap	1
2	V3152	O-ring 135	1
3	V3177-01	Injector Screen	1
4	V3010-1Z	Injector Assy. Z Plug	1
5	V3010-1B	INJECTOR ASSY B BROWN	
	V3010-1C	INJECTOR ASSY C VIOLET	
	V3010-1E	INJECTOR ASSY E WHITE	
	V3010-1H	INJECTOR ASSY H GREEN	
Not Shown	V3170	O-ring 011	*
Not Shown	V3171	O-ring 013	*

* The injector plug and the injector each contain one 011 (lower) and 013 (upper) o-ring

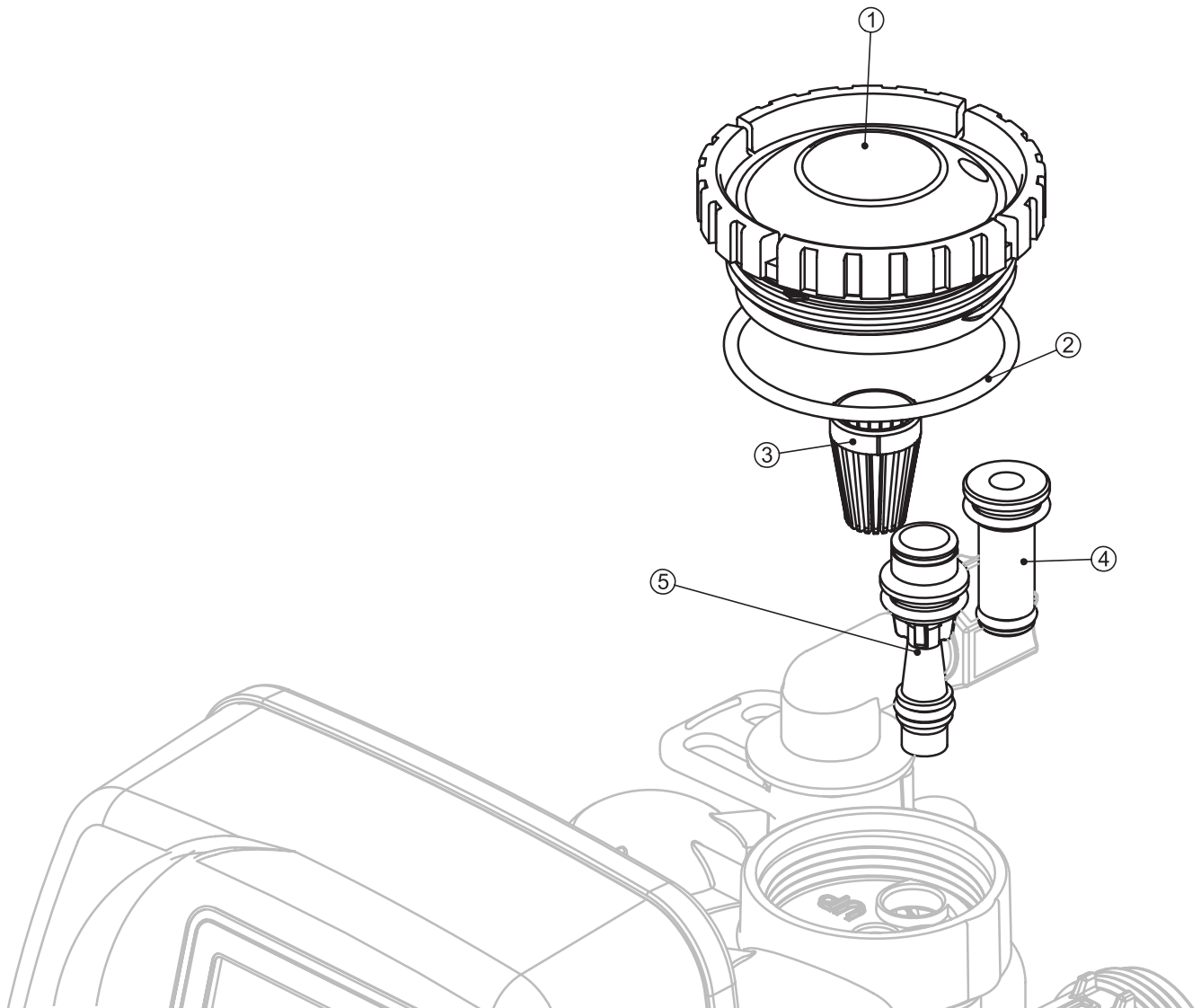

SECTION 8: PARTS (Continued)

COMPONENT PARTS LIST

Refill Flow Control Assembly

Drawing No.	Order No.	Description	Quantity
1	H4615	Elbow Locking clip	1
2	JCP-P-6	Polytube insert 3/8"	1
3	JCPG-6PBLK	Nut 3/8"	1
4	H4613	Elbow Cap 3/8"	1
5	V3163	O-ring 019	1
6	V3165-01*	BLFC Retainer Assembly**	1
7	V3182	BLFC	1
Not Shown	H4650	Elbow 1/2" with nut and insert	Option

* Assembly includes V3182 BLFC.

** Includes drawing #7.

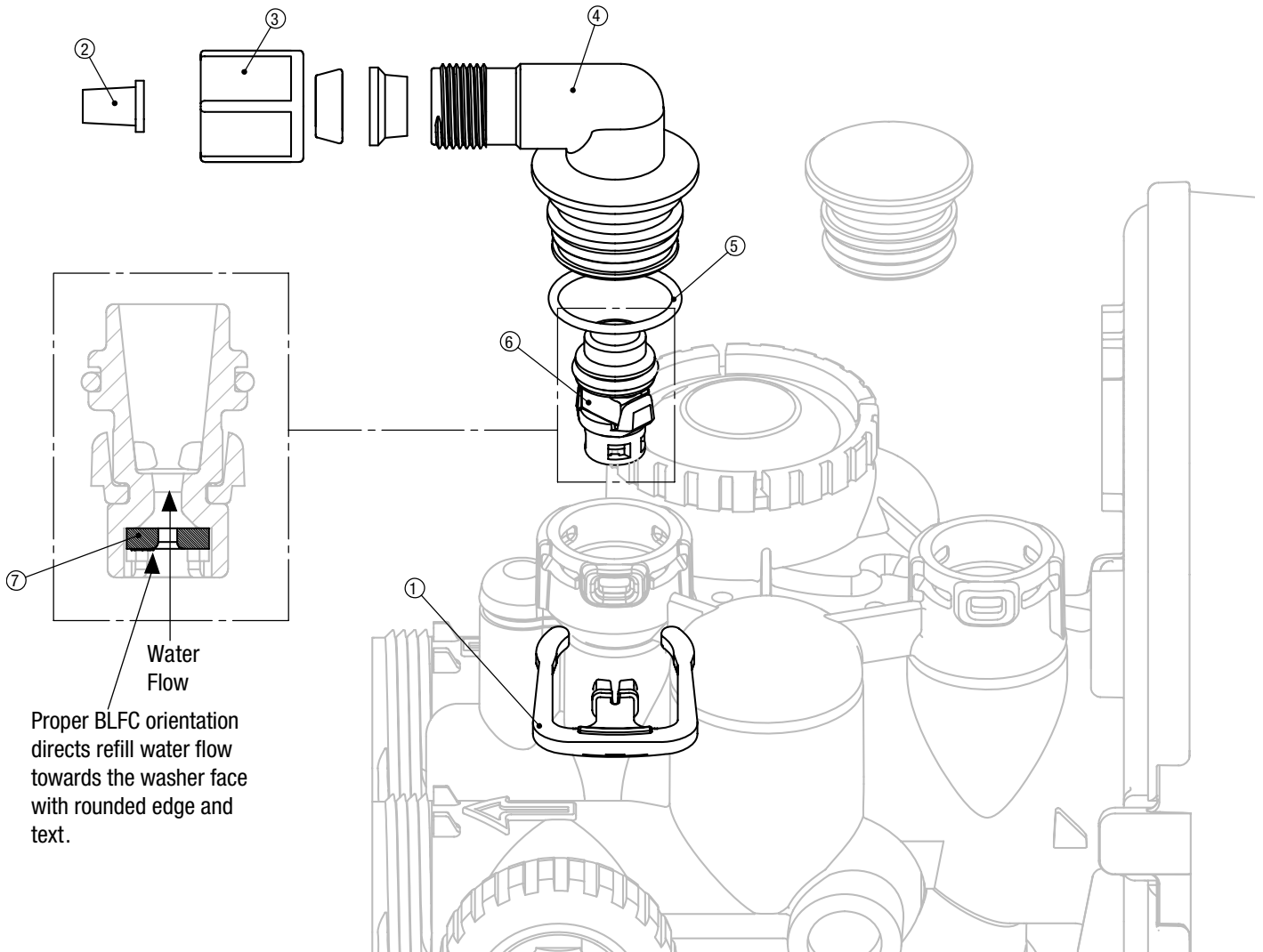

SECTION 8: PARTS (Continued)

COMPONENT PARTS LIST

Drain Line - 3/4"

Drawing No.	Order No.	Description	Quantity
1	H4615	Elbow Locking Clip	1
2	PKP10TS8-BULK	Polytube insert 5/8	1
3	V3192	Nut 3/4 Drain Elbow	1
4	V3158-01	Drain Elbow 3/4 Male	1
5	V3163	O-ring 019	1
6	V3159-01	DLFC Retainer Assembly	1
7	V3162-013	DLFC 1.3 gpm for 3/4	One DLFC must be used if 3/4 fitting is used
	V3162-017	DLFC 1.7 gpm for 3/4	
	V3162-027	DLFC 2.7 gpm for 3/4	
	V3162-053	DLFC 5.3 gpm for 3/4	

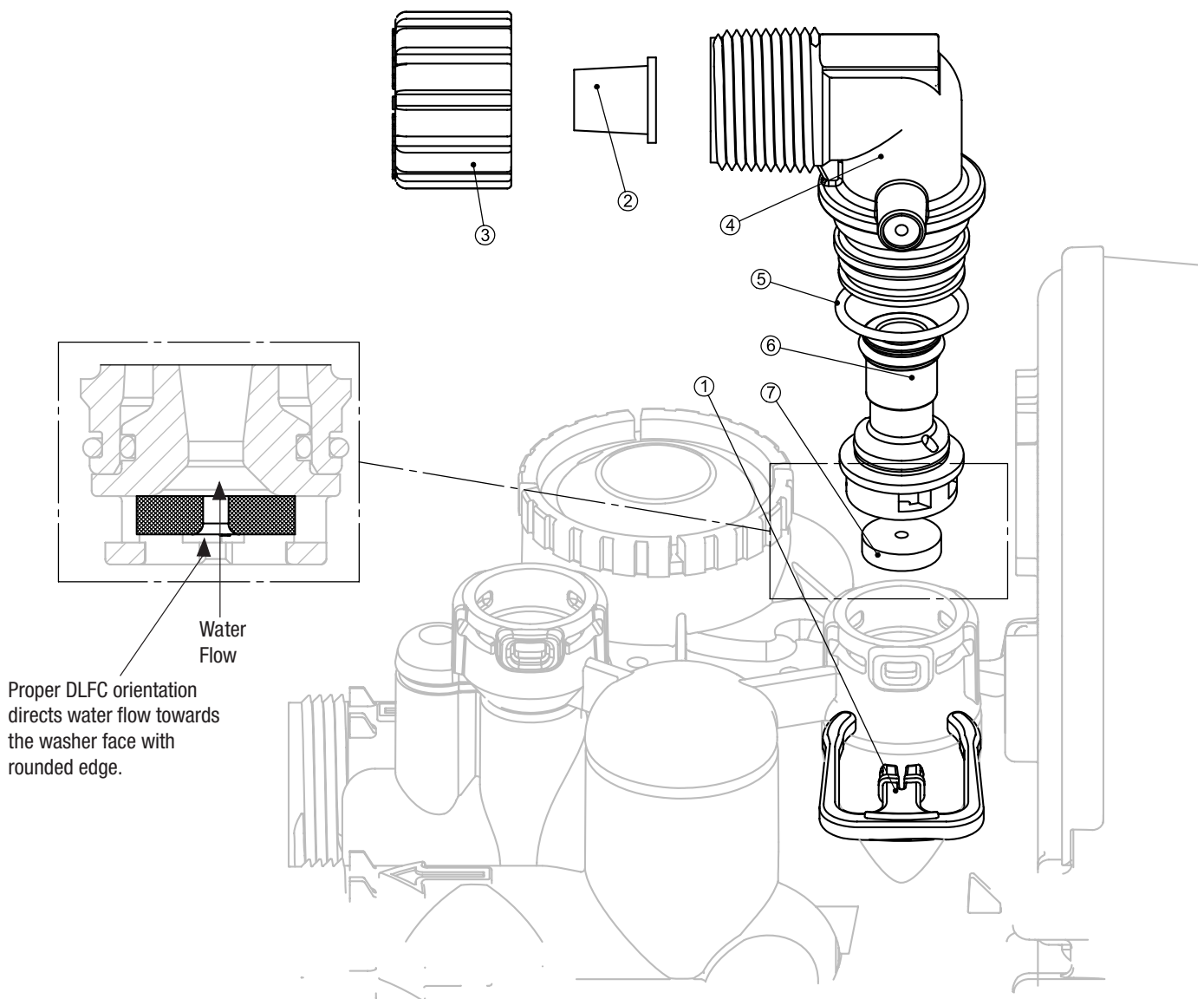

SECTION 8: PARTS (Continued)

COMPONENT PARTS LIST

Water Meter and Meter Plug

Drawing No.	Order No.	Description	Quantity
1	V3151	Nut 1" QC	1
2	V3003	Meter Assembly (includes drawing #3 & #4)	1
3	V3118-01	Turbine	1
4	V3105	O-ring 215	1
5	V3003-01	Meter Plug Assembly	1

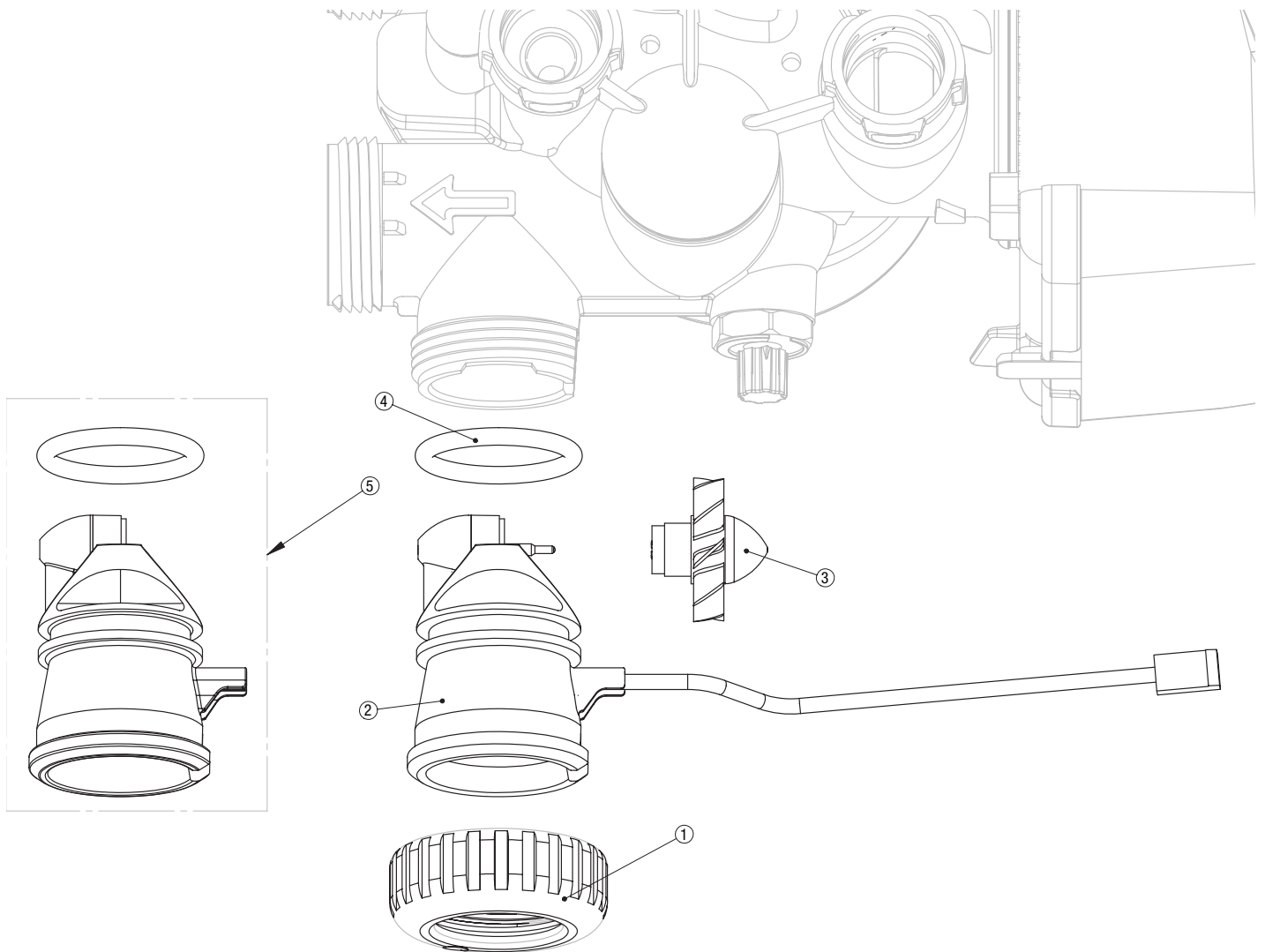

SECTION 8: PARTS (Continued)

COMPONENT PARTS LIST

Order No: V3007-02
Description: Fitting 1" Brass Sweat Assembly

Drawing No.	Order No.	Description	Quantity
1	V3151	Nut 1" Quick Connect	1
2	V3150	Split Ring	1
3	V3105	O-ring 215	1
4	V3188	Fitting 1" Brass Sweat Assembly	1

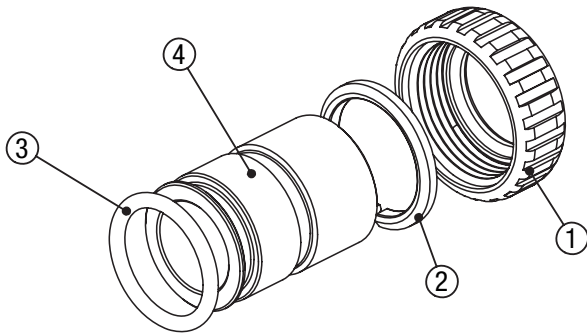

Order No: V3007-03
Description: Fitting 3/4" Brass Sweat Assembly

Drawing No.	Order No.	Description	Quantity
1	V3151	Nut 1" Quick Connect	1
2	V3150	Split Ring	1
3	V3105	O-ring 215	1
4	V3	Fitting 3/4" Brass Sweat Assembly	1

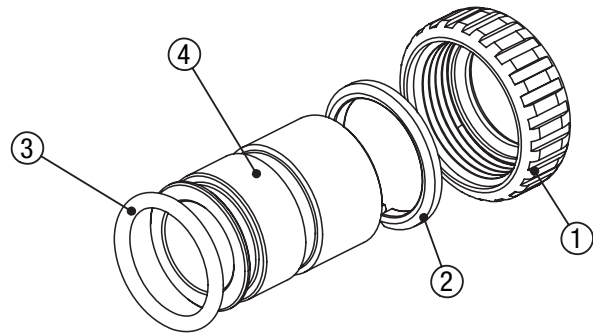

Order No: V3007-04
Description: Fitting 1" Plastic Male NPT Assembly

Drawing No.	Order No.	Description	Quantity
1	V3151	Nut 1" Quick Connect	1
2	V3150	Split Ring	1
3	V3105	O-ring 215	1
4	V3164	Fitting 1" Plastic Male NPT	1

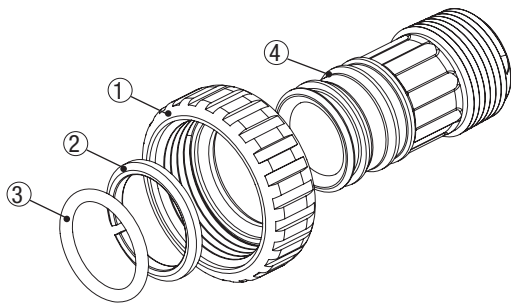

Order No: V3007-05
Description: Fitting 1-1/4" Plastic Male NPT Assembly

Drawing No.	Order No.	Description	Quantity
1	V3151	Nut 1" Quick Connect	1
2	V3150	Split Ring	1
3	V3105	O-ring 215	1
4	V3317	Fitting 1-1/4" Plastic Male NPT	1

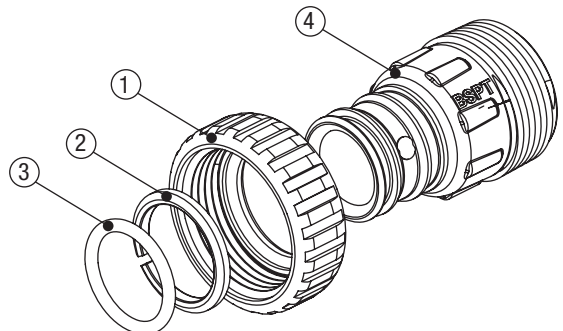

SECTION 8: PARTS (Continued) COMPONENT PARTS LIST

Bypass Valve

Drawing No.	Order No.	Description	Quantity
1	V3151	Nut 1" Quick Connect	2
2	V3150	Split Ring	2
3	V3105	O-ring 215	2
4	V3145	Bypass 1" Rotor	2
5	V3146	Bypass Cap	2
6	V3147	Bypass Handle	2
7	V3148	Bypass Rotor Seal Retainer	2
8	V3152	O-ring 135	2
9	V3155	O-ring 112	2
10	V3156	O-ring 214	2

V3191-01 Vertical Adapter Assembly

Order No.	Description	Quantity
V3151	Nut 1" Quick Connect	2
V3150	Split Ring	2
V3105	O-ring 215	2
V3191	Vertical Adapter	2

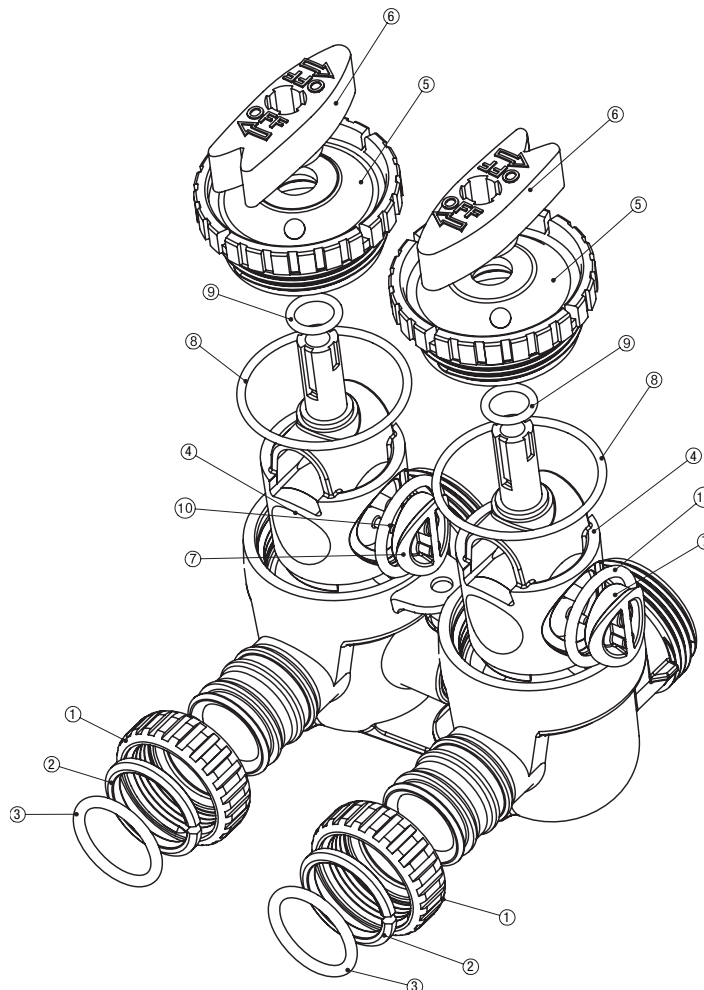

SECTION 8: PARTS (Continued)
COMPONENT PARTS LIST

Wrench

(Order No. V3193-01)

Although no tools are necessary to assembly or disassemble the valve, the wrench (shown in various positions on the valve) may be purchased to aid in assembly or disassembly.

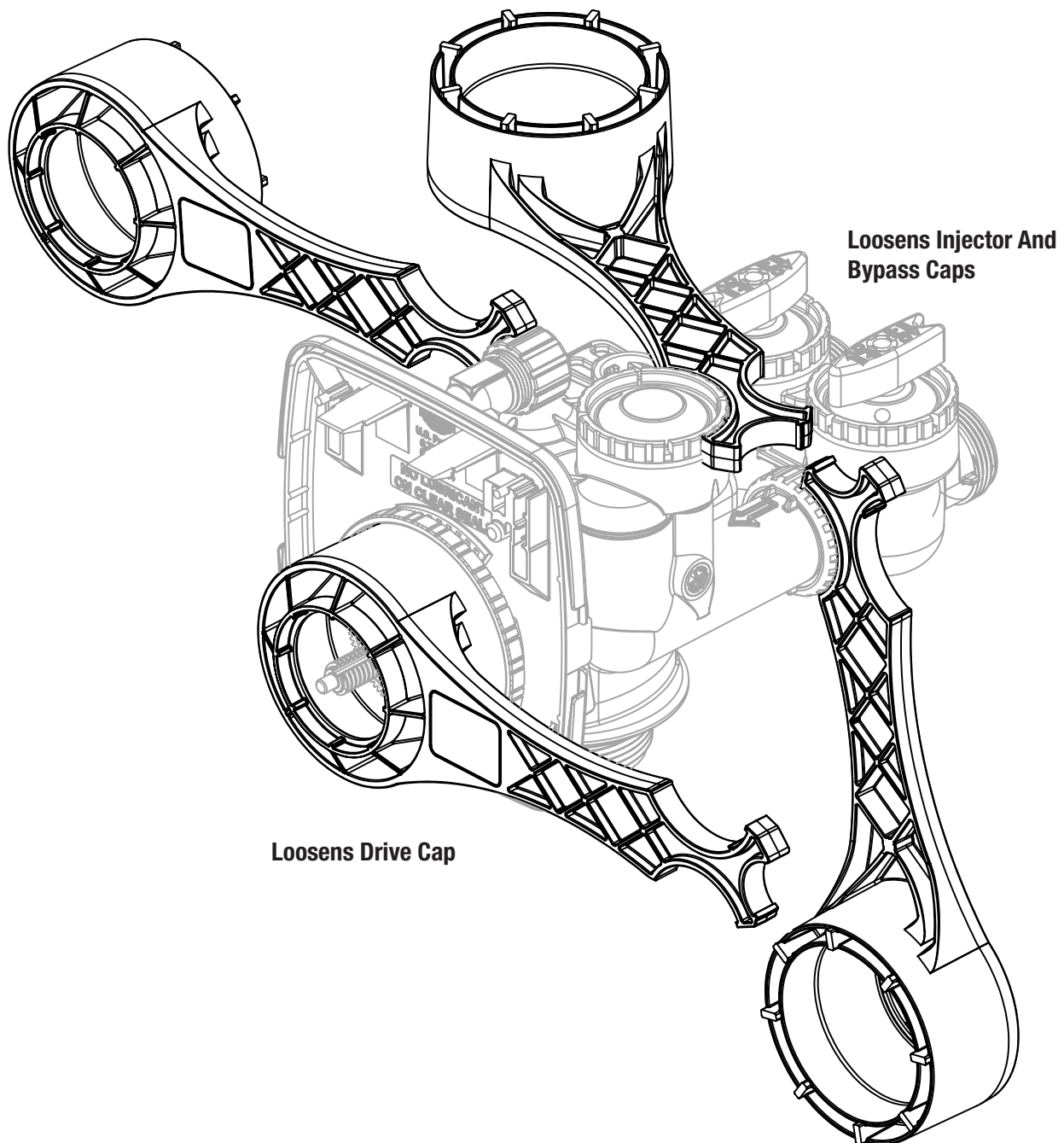

SECTION 9: LIMITED WARRANTY

Limited Warranty: 3M Purification Inc. warrants this Product to be free from defects in material and workmanship during normal use for the warranty period set forth below. The warranty period commences from the date of purchase. This warranty does not cover failures resulting from abuse, misuse, alteration or damage not caused by 3M Purification Inc. or failure to follow installation and use instructions. No warranty is given as to the service life of any filter cartridge, membrane, or media as it will vary with local water conditions and water consumption.

3M MAKES NO OTHER WARRANTIES OR CONDITIONS, EXPRESS OR IMPLIED, INCLUDING, BUT NOT LIMITED TO, ANY IMPLIED WARRANTY OR CONDITION OF MERCHANTABILITY OR FITNESS FOR A PARTICULAR PURPOSE OR ANY IMPLIED WARRANTY OR CONDITION ARISING OUT OF A COURSE OF DEALING, CUSTOMER OR USAGE OF TRADE.

If the Product is found defective within the warranty period, your exclusive remedy and 3M Purification Inc.'s sole obligation shall be, at 3M Purification Inc.'s option, to replace or repair the Product or refund the purchase price of the Product. This warranty does not cover labor. The remedy stated in this paragraph is Customer's sole remedy and 3M Purification Inc.'s exclusive obligation.

Warranty Period:

- One (1) year on the entire product unit
- Five (5) years on the media tank only (does not include internal component parts)
- Five (5) years on the control valve
- Five (5) years on salt storage container and components*

Limitation of Liability: 3M Purification Inc. will not be liable for any loss or damage arising from this 3M Purification Inc. product, whether direct, indirect, special, incidental, or consequential, regardless of the legal theory asserted, including warranty, contract, negligence or strict liability. Some states and countries do not allow the exclusion of limitation of incidental or consequential damages, so the above limitation or exclusion may not apply to you.

Warranty Claims:

To obtain warranty service, call 866.990.9785 or mail your request to: 3M Purification Inc., 400 Research Parkway, Meriden, CT 06450. Proof of purchase (original sales receipt) must accompany the warranty claim, along with a complete description of the Product, model number and alleged defect. **This warranty gives you specific legal rights, and you may have other rights which may vary from state to state, or country to country.**

* Water Softeners only



3M Purification Inc.
3M Separation and
Purification Sciences Division
400 Research Parkway
Meriden, CT 06450 U.S.A.
(800) 243-6894
(203) 237-5541
www.3M.com/purification

3M is a trademark of 3M Company.
Please recycle. Printed in U.S.A.
©2021 3M Company. All rights reserved.
34-8726-8629-9