



**GENERAL MONITORS**

# **Model FL4000H**

Multi-Spectral Infrared  
Flame Detector



The information and technical data disclosed in this document may be used and disseminated only for the purposes and to the extent specifically authorized in writing by General Monitors.

**Instruction Manual**

**04-10**

General Monitors reserves the right to change published specifications and designs without prior notice.

**Part No.**  
**Revision**

**MANFL4000H-EU**  
**C/04-10**

This page intentionally left blank

# Table of Contents

<b>TABLE OF FIGURES .....</b>	<b>V</b>
<b>TABLE OF TABLES.....</b>	<b>VI</b>
<b>QUICK START GUIDE .....</b>	<b>7</b>
Mounting and Wiring the Detector .....	7
Applying Power to the Detector .....	9
Testing the Detector Using a Test Lamp .....	10
<b>ABOUT THIS MANUAL .....</b>	<b>11</b>
Format Conventions.....	11
Other Sources of Help.....	11
<b>1.0 BEFORE INSTALLATION.....</b>	<b>12</b>
1.1 System Integrity Verification .....	12
1.2 Commissioning Safety Systems .....	12
1.3 Special Warnings .....	12
1.4 Glossary of Terms.....	13
<b>2.0 PRODUCT OVERVIEW.....</b>	<b>15</b>
2.1 General Description .....	15
2.2 Features and Benefits.....	15
2.3 Applications.....	16
2.4 Principle of Operation.....	16
<b>3.0 INSTALLATION.....</b>	<b>22</b>
3.1 Unpacking the Equipment.....	22
3.2 Required Tools.....	22
3.3 Detector Location Guidelines.....	23
3.4 Field Wiring Procedure .....	27
3.5 Detector Mounting and Installation .....	28
3.6 Terminal Connections .....	30
3.7 Switch Selectable Options .....	37
3.8 Powering of the FL4000H .....	39
3.9 Power up Grounding of the Test and Relay Reset Lines.....	39
<b>4.0 MODBUS INTERFACE .....</b>	<b>40</b>
4.1 Introduction .....	40
4.2 Communication Slave Address.....	40
4.3 Baud Rate .....	40
4.4 Data Format.....	40
4.5 Supported Function Codes .....	41
4.6 Modbus Read Status Protocol (Query / Response).....	41
4.7 Modbus Write Command Protocol (Query / Response) .....	42
4.8 Exception Responses and Exception Codes.....	42



---

4.9	Command Register Locations.....	44
4.10	Command Register Details .....	48
<b>5.0</b>	<b>MAINTENANCE .....</b>	<b>58</b>
5.1	General Maintenance.....	58
5.2	Cleaning the Sapphire Window.....	58
5.3	Sensitivity Check.....	59
5.4	Storage.....	59
<b>6.0</b>	<b>TROUBLESHOOTING.....</b>	<b>60</b>
6.1	Troubleshooting Chart .....	60
6.2	Final Assembly.....	61
<b>7.0</b>	<b>CUSTOMER SUPPORT .....</b>	<b>62</b>
7.1	General Monitors' Offices .....	62
7.2	Other Sources of Help .....	62
<b>8.0</b>	<b>APPENDIX.....</b>	<b>63</b>
8.1	Warranty.....	63
8.2	Specifications .....	63
8.3	Regulatory Agency Approvals.....	65
8.4	Response to False Stimuli .....	66
8.5	Spare Parts and Accessories.....	67
<b>9.0</b>	<b>APPENDIX A .....</b>	<b>70</b>

**FL4000H HART COMMUNICATION**

## Table of Figures

Figure 1: FL4000H Housing .....	7
Figure 2: Mounting Instruction .....	8
Figure 3: Wall Mounting Assembly .....	8
Figure 4: Bracket Assembly .....	9
Figure 5: Field Terminations Showing Wiring for Fire Alarm Systems .....	9
Figure 6: FL4000H Front View .....	15
Figure 7: Test Lamp Flashing Option (Auto-detection) .....	20
Figure 8: Grounding of Test Wire or Modbus Command Options .....	21
Figure 9: Horizontal FOV – <i>n</i> -Heptane – High Sensitivity .....	24
Figure 10: Horizontal FOV – <i>n</i> -Heptane – Medium Sensitivity .....	24
Figure 11: Horizontal FOV – <i>n</i> -Heptane – Low Sensitivity .....	25
Figure 12: Vertical FOV – <i>n</i> -Heptane – High Sensitivity .....	25
Figure 13: Vertical FOV – <i>n</i> -Heptane – Medium Sensitivity .....	26
Figure 14: Vertical FOV – <i>n</i> -Heptane – Low Sensitivity .....	26
Figure 15: FL4000H Housing .....	27
Figure 16: Detector Mounting and Installation .....	29
Figure 17: Dimensional Drawing .....	30
Figure 18: Wire-Strip Lengths .....	30
Figure 19: Base Housing and Terminal Blocks .....	31
Figure 20: Terminal Connections .....	32
Figure 21: Relay Contacts .....	33
Figure 22: Wiring Diagram – Reset Relays, Test Mode, & Alarm Test .....	35
Figure 23: Dipswitch Location .....	38
Figure 24: Command Register .....	50
Figure 25: Optical Parts to Clean .....	58
Figure 26: FL4000H Cross-Section View .....	61
Figure 27: Functional Board Located Under TL105 Lamp Assembly .....	70

## Table of Tables

Table 1: Glossary of Terms .....	13
Table 2: Sample Industry Applications .....	16
Table 3: LED sequence for each operating condition .....	17
Table 4: Required Tools .....	22
Table 5: Maximum Specified Fields of View at High Sensitivity .....	23
Table 6: Sensitivity Settings for <i>n</i> -Heptane .....	26
Table 7: Terminal Block Connections .....	31
Table 8: Alarm Relay Terminals .....	32
Table 9: Warning Relay Terminals .....	33
Table 10: Fault Relay Terminals .....	34
Table 11: Alarm Reset Terminal .....	34
Table 12: Test Mode Terminal .....	34
Table 13: Alarm Test Terminals .....	35
Table 14: Analog Output Terminal .....	35
Table 15: Analog Output Levels .....	36
Table 16: Maximum Cable Lengths for 250 Ω Inputs .....	36
Table 17: Power Terminals .....	36
Table 18: Maximum Cable Lengths for +24 VDC .....	36
Table 19: Modbus Terminals .....	37
Table 20: Chassis Ground Terminal .....	37
Table 21: Dipswitch Options .....	38
Table 22: Selectable Baud Rates .....	40
Table 23: Selectable Data Formats .....	40
Table 24: Modbus Read Register(s) Request .....	41
Table 25: Modbus Read Register(s) Response .....	41
Table 26: Modbus Write Register Request .....	42
Table 27: Modbus Write Register Response .....	42
Table 28: Exception Response .....	43
Table 29: Exception Codes .....	43
Table 30: Command Register Locations .....	44
Table 31: Status Mode Values .....	48
Table 32: Modbus Error Codes .....	49
Table 33: Com1 Baud Rate .....	51
Table 34: Selectable Data Formats .....	51
Table 35: Event Log Clock Time Format .....	55
Table 36: Troubleshooting Chart .....	60
Table 37: GM Locations .....	62
Table 38: False Alarm Immunity at High Sensitivity .....	66
Table 39: Flame Response in the Presence of False Alarm Sources (High Sensitivity) .....	67
Table 40: List of Spare Parts .....	68
Table 41: Detector Test Mode Initiation or/Detector Alarm Trigger with Test Lamp .....	71

## Quick Start Guide

### Mounting and Wiring the Detector

Pay special attention to the conduit seal entry (Canadian Electrical Code Handbook Part 1, Section 18-154). Mount the detector by using the swivel mount or mounting bracket hardware.

The following procedure should be used in conjunction with the housing diagram below to disassemble the Optical Housing Assy for wiring:

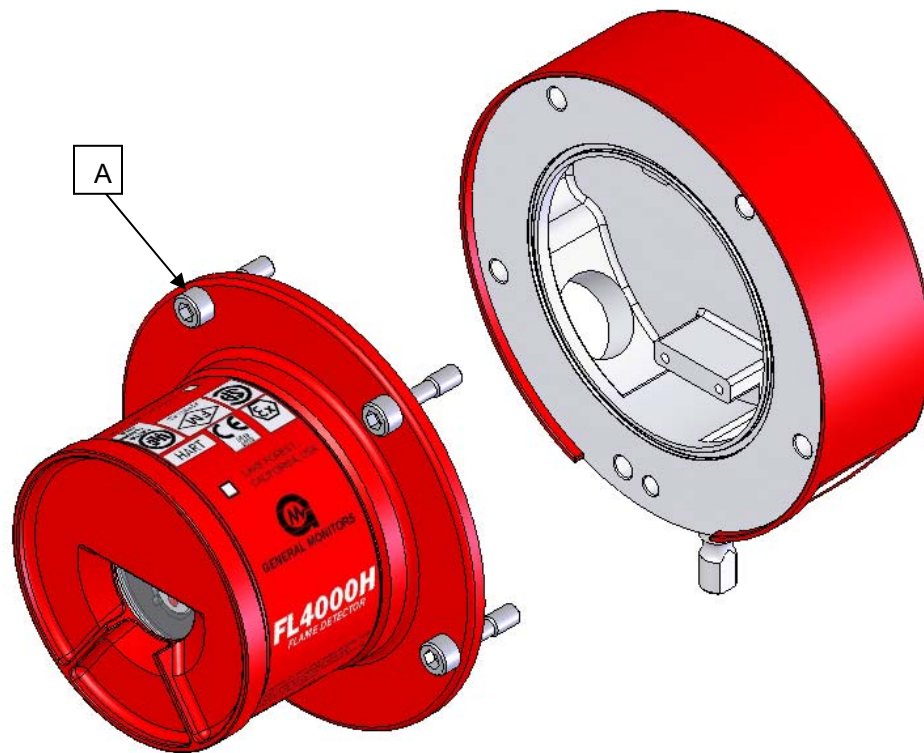

**Figure 1: FL4000H Housing**

1. Loosen the captive screws (A) located on the Optical Housing Assy.
2. Pull the Optical Housing Assy from the Base Housing Assy to separate, gently rock from side to side if necessary to loosen the connector's grip.
3. Wire the unit to the site-wiring following the connection diagram shown in Figure 5.
4. Reassemble the unit using steps 1 thru 2 in reverse.



**CAUTION:** Do not unscrew the field wiring board from the base housing assembly for wiring.

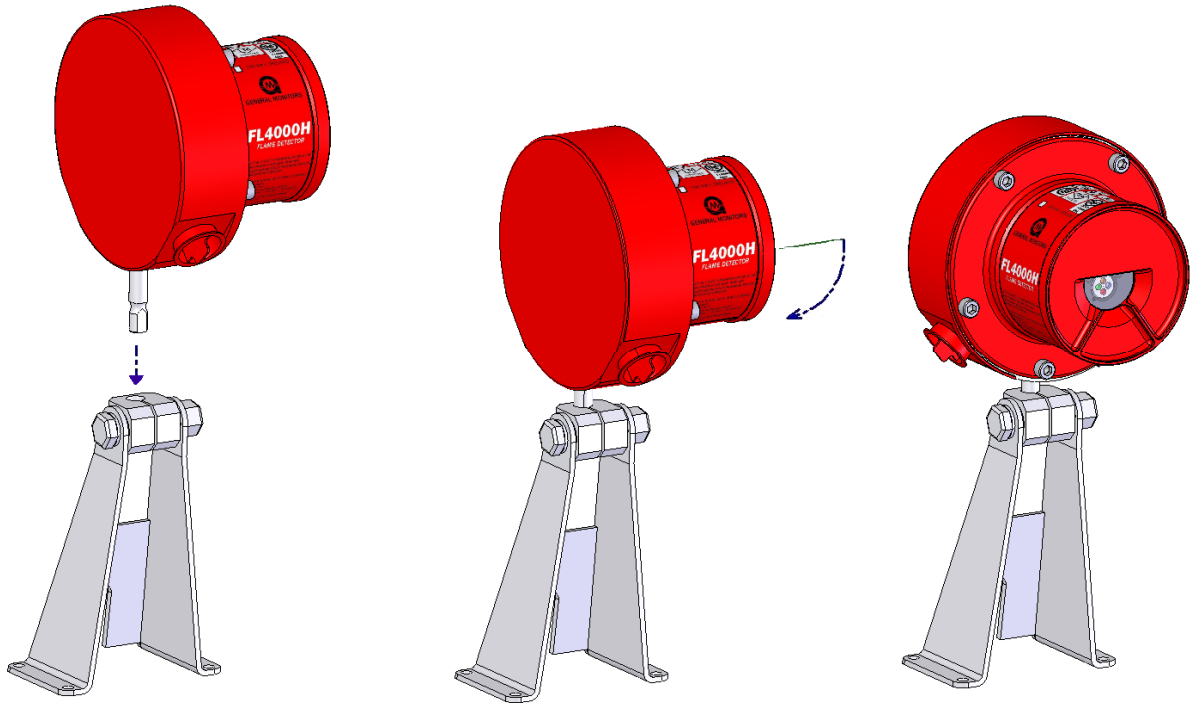

Figure 2: Mounting Instruction

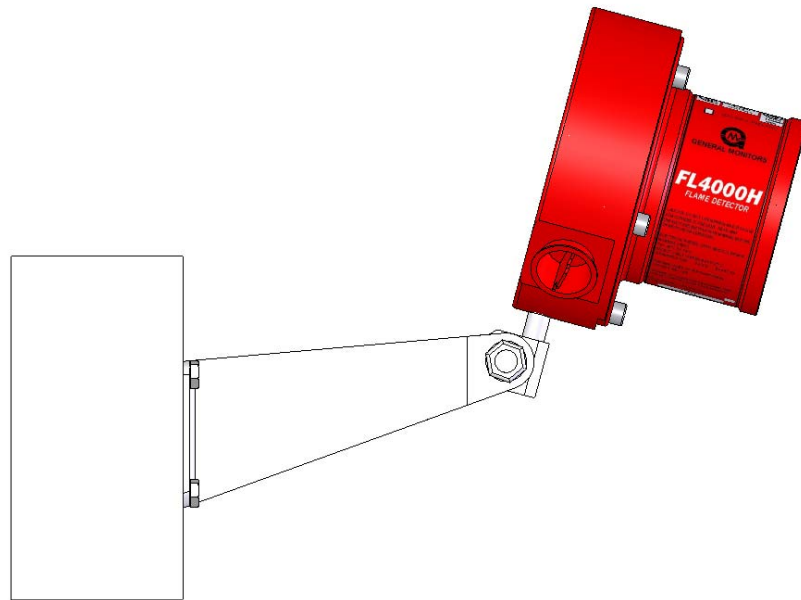
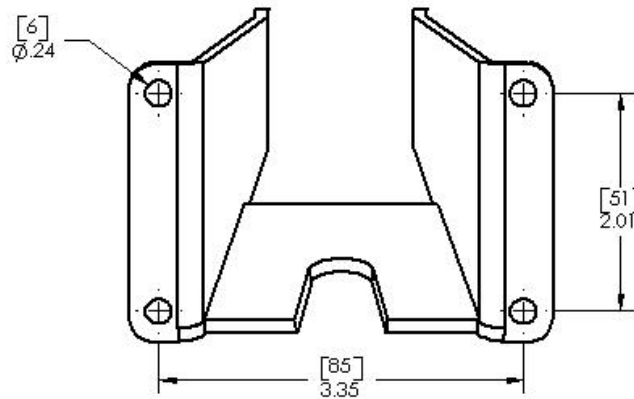
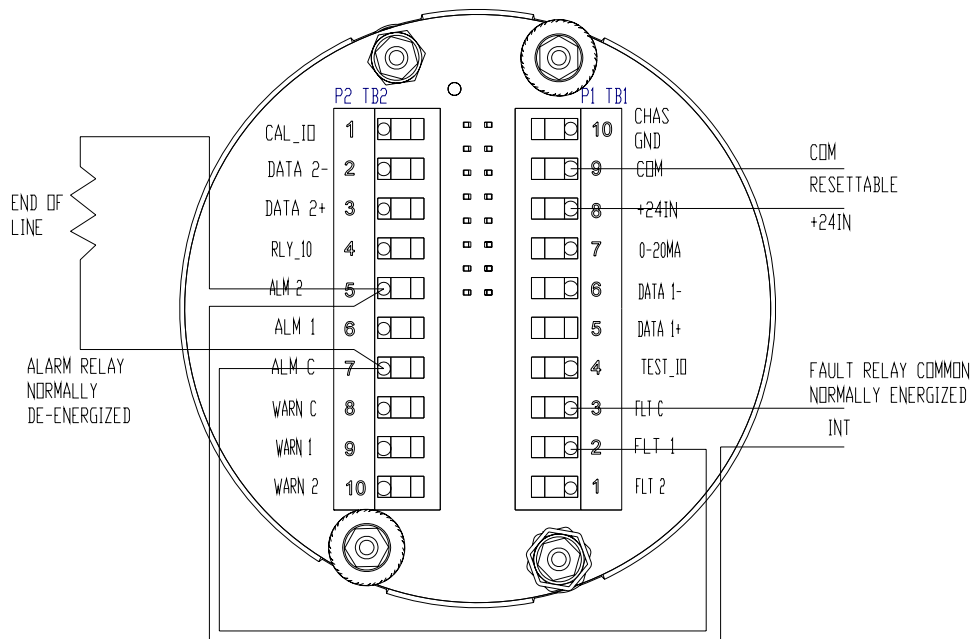

Figure 3: Wall Mounting Assembly



**Figure 4: Bracket Assembly**



**Figure 5: Field Terminations Showing Wiring for Fire Alarm Systems<sup>1</sup>**

## Applying Power to the Detector

Two light emitting diodes (LED's) are visible through the window. Immediately upon powering up the detector, both LED's will start blinking alternately for 15 seconds. The unit will then enter the "Ready" mode. During the "Ready" mode, the green LED will flash off 0.5 seconds every 5 seconds.

<sup>1</sup> Recommended by Underwriters' Laboratories of Canada.

## Testing the Detector Using a Test Lamp

Test the integrity of your system by using a Test Lamp. The original configuration (i.e. sensitivity and relay options) can be changed by referring to Section 3.7 , and then changing the dipswitch settings located on the bottom of the power board (SW1).

The instrument is now ready to operate. Please consult the Test Lamp manual for more information on the instrument's many features. If you have any problems in the set-up or testing of the detector, please refer to the "Trouble Shooting Section", or call the factory direct.

## About This Manual

This manual provides instructions for installing, operating, and maintaining the General Monitors (GM) FL4000H Flame Detector. The intended audience includes installation personnel, field service technicians, Modbus programmers, and other technical staff involved in installing and using an FL4000H.

### Format Conventions

Several format conventions are used throughout this manual for Notes, Cautions, Warnings, User Menus, and Modbus notations. These conventions are described below.

### Notes, Cautions, and Warnings

---

**NOTE:** Notes provide supplementary details such as exception conditions, alternate methods for a task, time saving tips, and references to related information.

---



**CAUTION:** These notices describe precautions to prevent hazardous conditions that may damage the equipment.



**WARNING:** These notices describe precautions to prevent hazardous conditions that may cause injury to people working with the equipment.

### Modbus Register Formats

Hexadecimal numbers are used in Modbus registers and are indicated by the addition of either “0x” in front of a number or “h” after the number (example: 0x000E or 000Eh, respectively).

### Other Sources of Help

General Monitors provides extensive documentation, white papers, and product literature for the company’s complete line of safety products, many of which can be used in combination with the FL4000H. Many of these documents are available online at the General Monitors website at <http://www.generalmonitors.com>.

### Contacting Customer Support

For additional product information not contained in this manual, please contact General Monitors Customer Support. Refer to Section 7.0 for contact information.

## 1.0 Before Installation

### 1.1 System Integrity Verification

General Monitors' mission is to benefit society by providing safety solutions through industry leading products, services, and systems that save lives and protect capital resources from the dangers of hazardous flames, gases, and vapors.

General Monitors' safety products should be handled carefully and installed, calibrated, and maintained in accordance with the individual product instruction manuals. To ensure operation at optimum performance, General Monitors recommends that prescribed maintenance procedures be followed.

### 1.2 Commissioning Safety Systems

Before power up, verify wiring, terminal connections, and stability of the mountings for all essential safety equipment including, but not limited to:

- Power supplies
- Control modules
- Field detection devices
- Signaling / output devices
- Accessories connected to field and signaling devices

After the initial power up and any factory specified warm-up period of the safety system, verify that all signal outputs, to and from the devices and modules, are within the manufacturer's specifications. Initial calibration / calibration checking / testing should be performed according to the manufacturer's recommendations and instructions.

Proper system operation should be verified by performing a full, functional test of all component devices of the safety system, ensuring that the proper alarm levels occur. Fault / Malfunction circuit operations should be verified.

### 1.3 Special Warnings



**WARNING:** Toxic, combustible, and flammable gases and vapors are dangerous. Extreme caution should be used when these hazards are present.

Through engineering design, testing, manufacturing techniques, and rigid quality control, General Monitors supplies the finest flame detection systems available. The user must recognize his responsibility for maintaining the flame detection system in operational condition.

The FL4000H contains components that can be damaged by static electricity. In order to avoid static electricity, special care must be taken when wiring the system to ensure that only the connection points are touched.

The FL4000H is rated Explosion Proof (XP) for use in hazardous locations.

Conduit seals or suitably approved EExd glands must be used to preserve the explosion proof safety of the FL4000H and help prevent ingress of water from the conduit systems.

Silicone Room Temperature Vulcanization (RTV) is not an approved moisture barrier. If used, damage to internal components will arise.

Damage to the FL4000H housing where any internal components or protective seals are broken, compromises the safety and usability of the device. An FL4000H with a damaged or open housing should not be used in a hazardous environment. Such damage includes fractures in the housing, cracks in any internal components, or cracks in the protective seals.

## 1.4 Glossary of Terms

**Table 1: Glossary of Terms**

<b>Term / Abbreviation</b>	<b>Definition</b>
<b>A</b>	Amps
<b>AC</b>	Alternating Current
<b>ANN</b>	Artificial Neural Network
<b>AWG</b>	American Wire Gauge
<b>Baud Rate</b>	The number of signal level changes per second in a line, regardless of the information content of those signals
<b>bps</b>	Bits per second
<b>Cable Armor</b>	Cable having interlocked or corrugated armor where it is essential to provide positive grounding of cable armor
<b>Cable Screen</b>	Mesh surrounding a cable
<b>COM</b>	DC Ground
<b>COPM</b>	Continuous Optical Path Monitoring
<b>CR</b>	Control Room
<b>CRC</b>	Cycle Redundancy Check
<b>DC</b>	Direct Current
<b>DCS</b>	Distributed Control System
<b>De-Energized</b>	To disconnect from a power source
<b>DSP</b>	Digital Signal Processor
<b>EEPROM</b>	Electrically Erasable Programmable Read-Only Memory
<b>EMI</b>	Electromagnetic Interference
<b>ENERGIZED</b>	To apply voltage or energy
<b>FOV</b>	Field of View
<b>FS</b>	Full Scale
<b>GM</b>	General Monitors
<b>HART</b>	Highway Addressable Remote Transducer-communication protocol
<b>Hex</b>	Hexadecimal Number
<b>I / O</b>	Input / Output
<b>Instrument Earth</b>	Grounded using a grounding strap
<b>Latching</b>	Refers to relays remaining in the “on” state even after the “on” condition has been removed
<b>LED</b>	Light Emitting Diode
<b>LSB</b>	Least Significant Bit
<b>mA</b>	Milli-Amps refers to 1/1000 of an Amp
<b>Master</b>	Controls one or more devices or processes
<b>Modbus</b>	Master-slave messaging structure
<b>N/A</b>	Not Applicable
<b>NC</b>	Normally Closed
<b>NO</b>	Normally Open

<b>Term / Abbreviation</b>	<b>Definition</b>
<b>Non-Latching</b>	Refers to relays being reset to the initial state after “on” condition has been removed
<b>NPT</b>	National Pipe Thread
<b>OV Return</b>	Over voltage return
<b>0VDC</b>	Power Supply Common Ground
<b>Oxidation</b>	Combining with Oxygen
<b>PCB</b>	Printed Circuit Board
<b>PLC</b>	Programmable Logic Controller
<b>ppm</b>	Parts per million
<b>RFI</b>	Radio Frequency Interference
<b>RMS</b>	Root-Mean-Square
<b>ROM</b>	Read Only Memory
<b>RTV</b>	Room Temperature Vulcanization
<b>Safety Earth</b>	Grounded to the earth
<b>Slave</b>	One or more devices or processes controlled by a master controller
<b>SMT</b>	Surface Mount Technology
<b>SPAN Value</b>	The programmed range of measurable parts per million
<b>SPDT</b>	Single Pole, Double Throw
<b>SPST</b>	Single Pole, Single Throw
<b>TB</b>	Terminal Block
<b>V</b>	Volts
<b>VAC</b>	Volts Alternating Current
<b>VDC</b>	Volts Direct Current
<b>XP</b>	Explosion Proof

## 2.0 Product Overview

### 2.1 General Description

The General Monitors' FL4000H is a Multi-Spectral Infrared (MSIR) Flame Detector (Figure 6). The FL4000H employs state-of-the-art infrared (IR) detectors and a sophisticated *artificial neural network* (ANN) based signal processing to produce a system that is highly immune to false alarms caused by lightning, sunlight reflection, arc-welding, hot objects, and other sources of radiation. In addition, the FL4000H can see through most smoky type fires such as diesel, rubber, etc.

The FL4000H is certified as explosion proof for use in hazardous locations (Section 8.3.2). It can also be used for general-purpose, non-hazardous applications.

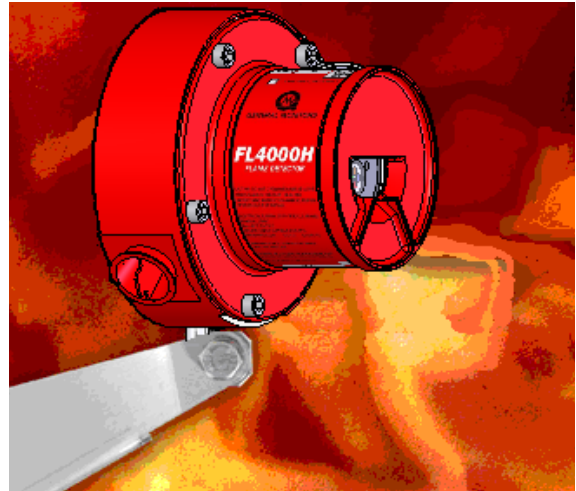

Figure 6: FL4000H Front View

### 2.2 Features and Benefits

**High False Alarm Immunity:** Provides reliable flame detection performance by utilizing a proprietary ANN processing algorithm to minimize false alarms. Please refer to Sec. □□□□ for more details on the behavior of the instrument in the presence of false stimuli.

**Wide Field of View (FOV):** Encompasses a larger area of detection with uniform sensing and no blind spots.

**Modular Design:** Results in low maintenance and reduced total cost of ownership.

**Compact Unitized Design:** Enhances ease of installation and maintenance.

**Continuous Optical Path Monitoring (COPM):** Regularly monitors the optical path to ensure the window is not dirty.

**0-20 mA Analog Output:** Transmits alarm and fault indication to a remote display, computer, or other device such as an alarm, dispensing device, or master controller.

**Dual Redundant Modbus RS-485 User Interface (Standard FL4000H Configuration):** Provides the capability to operate the FL4000H remotely, using 2 redundant channels. This interface allows the user to remotely change the alarm and warning relay settings, clear selected faults, clear error counters, change baud rates, and change formats for serial communication lines.

**HART Protocol<sup>2</sup> (Optional HART Configuration):** The HART equipped FL4000H supports the HART communication protocol version 6. Using this protocol, users can transmit diagnostics, settings, and other device status information that improves the efficiency of remote communication.

**NOTE:** FL4000H HART should not be used with General Monitors TA402A and FL802 Controllers.

<sup>2</sup> HART® is a registered trademark of the HART Communication Foundation

## 2.3 Applications

The FL4000H provides flame detection for a wide range of applications, including, but not limited to the following:

**Table 2: Sample Industry Applications**

<b>Industries</b>	<b>Sample Applications</b>
<b>Oil and Gas</b>	On and Offshore Platforms
<b>Gas Pipelines</b>	Compressor Buildings
<b>Airports / Military</b>	Airplane Hangars
<b>Gas Turbines</b>	Turbine Enclosures
<b>Chemical Plants</b>	Process Buildings
<b>Loading Terminals</b>	Trucking On / Off Loading Areas
<b>Petrochemical</b>	Process Areas
<b>Refineries</b>	Tank Farms and Process Areas

## 2.4 Principle of Operation

The FL4000H is a discriminating multi-spectral infrared detector, which makes use of infrared sensors for different IR wavelengths and characteristics. This combination provides a flame detection system, which is highly immune to false alarms.

The ANN network classifies the output signals from the detector as either fire or no-fire. The unit then produces the following output signals:

- 0 to 20 mA signal (3.5 to 20 mA with optional HART protocol)
- Immediate WARN relay contacts
- Time delayed ALARM relay contacts
- FAULT relay contacts
- RS-485 Modbus output
- Redundant RS-485 Modbus output

(Refer to Section 3.0 and Section 4.0 for more information on detector outputs.)

### 2.4.1 Visual Indicators

Two light emitting diodes (LEDs) are visible on the front detector window. These LEDs provide a visual indication that corresponds with the detector's outputs. The following LED flashing sequences indicate various operating conditions:

**Table 3: LED sequence for each operating condition.**

#	State	Red	Green	Notes
1	Power up	0.5 sec On	0.5 sec On	Alternating for 15 seconds
2	Ready	Off	5 sec On 0.5 sec Off	
3	Warning	0.5 sec On 0.5 sec Off	Off	
4	Alarm	0.2 sec On 0.2 sec Off	Off	
5	COPM Fault	Off	0.5 sec On 0.5 sec Off	
6	Low Voltage, Code or Data, Checksum Fault	Off	0.2 sec On 0.2 sec Off	
7	Test Mode Activated	Off	0.9 sec On 0.1sec Off	
8	Test Mode Warning	0.5 sec On	0.5 sec On	Alternating while detecting Test Lamp
9	Test Mode Alarm	0.2 sec On	0.2 sec On	Alternating while detecting Test Lamp

### 2.4.2 Continuous Optical Path Monitoring - COPM Circuitry

A self-testing feature called Continuous Optical Path Monitoring (COPM) checks the optical path, the detector(s), and the related electronic circuitry once every 2 minutes. If foreign material on the front surface of the FL4000H blocks the COPM light from reaching the detector(s) for four minutes, the unit will indicate FAULT. The optical FAULT outputs are a 2.0 mA (3.5 mA with HART) signal, de-energizing of the FAULT relay, and Modbus (RS-485) output signal. After a COPM FAULT, a COPM check is performed every twenty seconds. The COPM will resume a once per 2-minute check only after the obstruction is removed.



**CAUTION:** Dirty or partially blocked windows can significantly reduce the detector's field of view and detection distance.

**NOTE:** Because the optical path is checked once every 2 minutes and requires two check failures to produce a FAULT, it may take up to 4 minutes for the unit to detect an obstruction.

### 2.4.3 Test Mode Initiation

**NOTE:** The FL4000H will not detect a flame while in Test Mode.

The FL4000H has the ability to initiate a special Test Mode, which enables the user to test the response of the unit without the use of a flame source. Once the Test Mode has been activated, the unit will not detect a flame, but rather, responds to GM's Test Lamp as a simulated flame source.

There are four options for enabling Test Mode on the FL4000H:

1. Flashing of the Test Lamp
2. Momentary grounding of test wire<sup>3</sup>
3. Modbus command
4. HART command (available in HART configuration only)

<sup>3</sup> Underwriters' Laboratories of Canada (ULC) does not sanction the grounding of test wire as an approach for enabling Test Mode. For ULC-approved systems, only Test Lamp and HART and Modbus commands may be used.

Each time the Test Mode is activated and the Test Lamp is successfully detected, regardless of which option is used, the FL4000H maintains a timestamp of the test. This timestamp is available to the user via Modbus registers 0x6A, 0x6B, and 0x6C.

### 2.4.3.1 Test Mode Initiation via Test Lamp

---

**NOTE:** The Test Lamp sequence is depicted in Figure 7.

---

When the unit is in Operational Mode, the FL4000H recognizes the Test Lamp as a trigger to activate the Test Mode. Within 5-8 seconds of the Test Lamp (3.5 mA with HART) flashing, the FL4000H will detect the simulated flame source, drop the analog output to 1.5 mA (3.5 mA with HART), and change the LED flashing to indicate “Test Mode Activated” shown in sequence #7 of Table 3. The relay setting will remain at “Ready” during this operation.

Further continuous flashing of the Test Lamp in Test Mode enables the following sequence of events:

- After 2 seconds in Test Mode (Phase 2), the FL4000H indicates a Warning condition, by setting the analog output to 16 mA, changing the LED flashing to indicate “Test Mode Running” shown in sequence #8 (**Table 3**), and setting the relay to Warning State.
- After a user-selectable time delay of 0-30<sup>4</sup> seconds (Phase 3), the FL4000H displays an Alarm condition by setting the analog output to 20 mA, and setting the relay to Alarm State. The LED sequence changes to sequence #9 (Table 3) “Warning” mode.
- After 4.25 minutes in Alarm mode (Phase 4), the unit will return to Ready Mode by dropping the analog output to 4.3 mA, restoring the LED flashing to “Ready” shown in sequence #2 (**Table 3**), and setting the relay to Ready State. The FL4000H has now returned to flame detection status.

---

**NOTE:** After the test is initiated via the Test Lamp, all other commands are ignored until the Test Mode is over. While in Test Mode, the unit will not detect flames. Interruption of the Test Lamp flashing for more than 3 seconds will result in termination of the test sequence and a return to Ready Mode (Phase 0).

If a relay is latched, it must be manually reset via the reset relays line or a Modbus command. There is a 10 second restart delay. After the unit returns to Ready State from Phase 4, the unit waits for 10 seconds before a subsequent Test Lamp transition back to Phase 1.

---

### 2.4.3.2 Test Mode Initiation via Grounding of Test Wire or Modbus Command

---

**NOTE:** Both grounding of the test wire and Modbus command sequence are depicted in Figure 8.

---

Momentary grounding of a test wire or the Modbus test-mode-enable command causes the FL4000H to enter Test Mode. Initiation of Test Mode is indicated by the analog output dropping to 1.5 mA (3.5 mA with HART) and LED flashing in sequence # 7 (**Table 3**). The Test Lamp is not needed to enable Test Mode. If the Test Lamp is not used in Test Mode, the Test Mode times out in 3 minutes.

Flashing of the Test Lamp in the Test Mode enabled via test wire or Modbus results in the following sequence of events:

---

<sup>4</sup> Time delay can be set through Modbus to any value between 0 and 30 seconds, and via dipswitch to 0, 8, 10, or 14 seconds.

- After 5-8 seconds of the Test Lamp flashing in Phase 3, the FL4000H goes into Phase 4, indicating 1.5 mA (3.5 mA with HART) at the analog output, changing the LED flashing to indicate “Test Mode Running” shown in sequence #8 (**Table 3**).
- After 4.25 minutes in Phase 4, the FL4000H returns to Ready Mode, indicating 4.3 mA at the analog output, restoring the LED flashing to “Ready” shown in sequence #2 (**Table 3**).

---

**NOTE:** After the test is initiated via wire or Modbus; all other commands are ignored until the Test Mode is over. While in Test Mode, the unit will not detect flames. Interruption of the Test Lamp flashing for more than 3 seconds will result in termination of the test sequence and a return to Ready Mode (Phase 0).

---

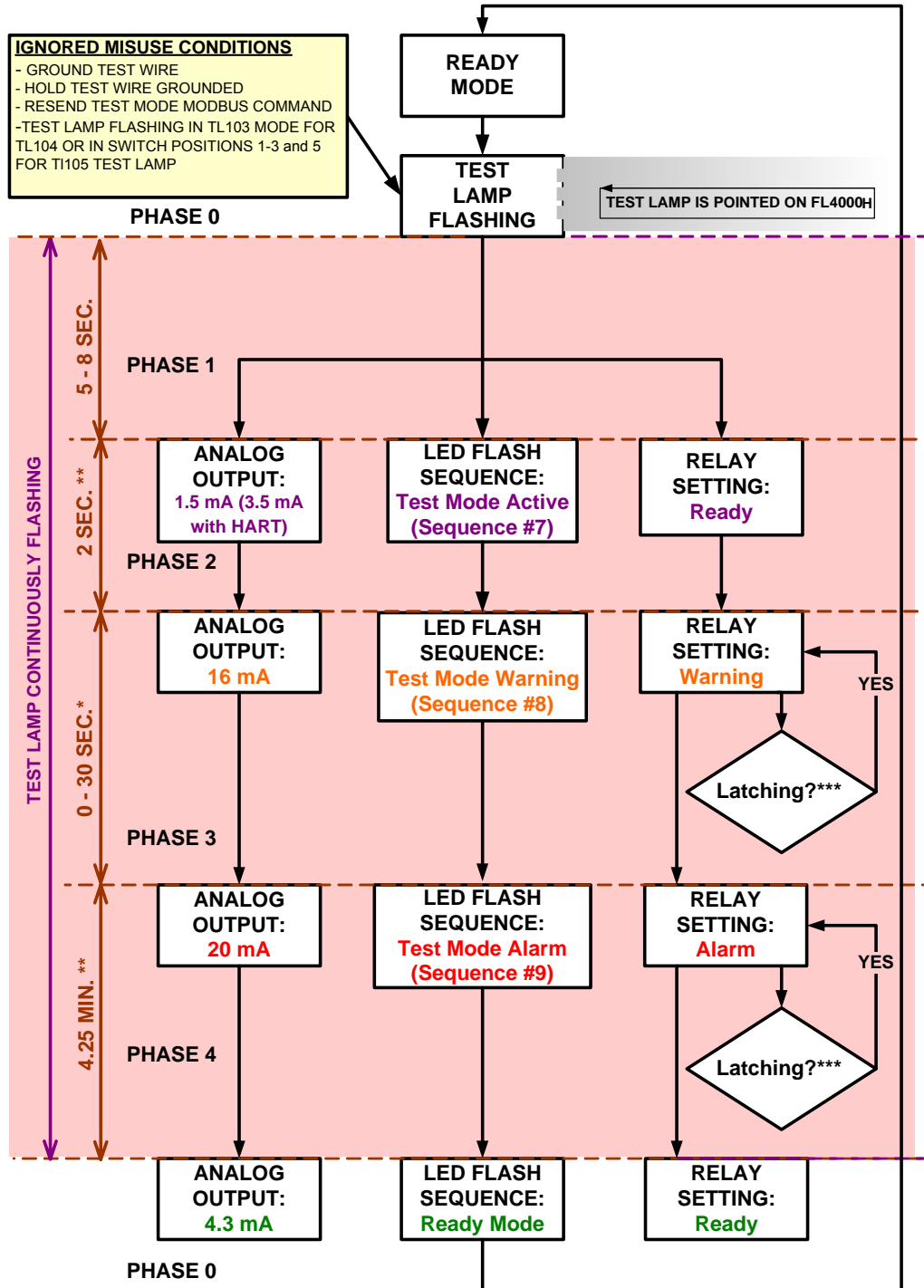

- \* USER SETTING VIA DIP SWITCH (0, 8, 10, OR 14 SEC) OR MODBUS (0 - 30 SEC)
- \*\* FACTORY PROGRAMMABLE
- \*\*\* IF RELAY IS LATCHED DURING THE TEST MODE, IT MUST BE MANUALLY RESET VIA RESET RELAYS LINE OR MODBUS COMMAND

Figure 7: Test Lamp Flashing Option (Auto-detection)

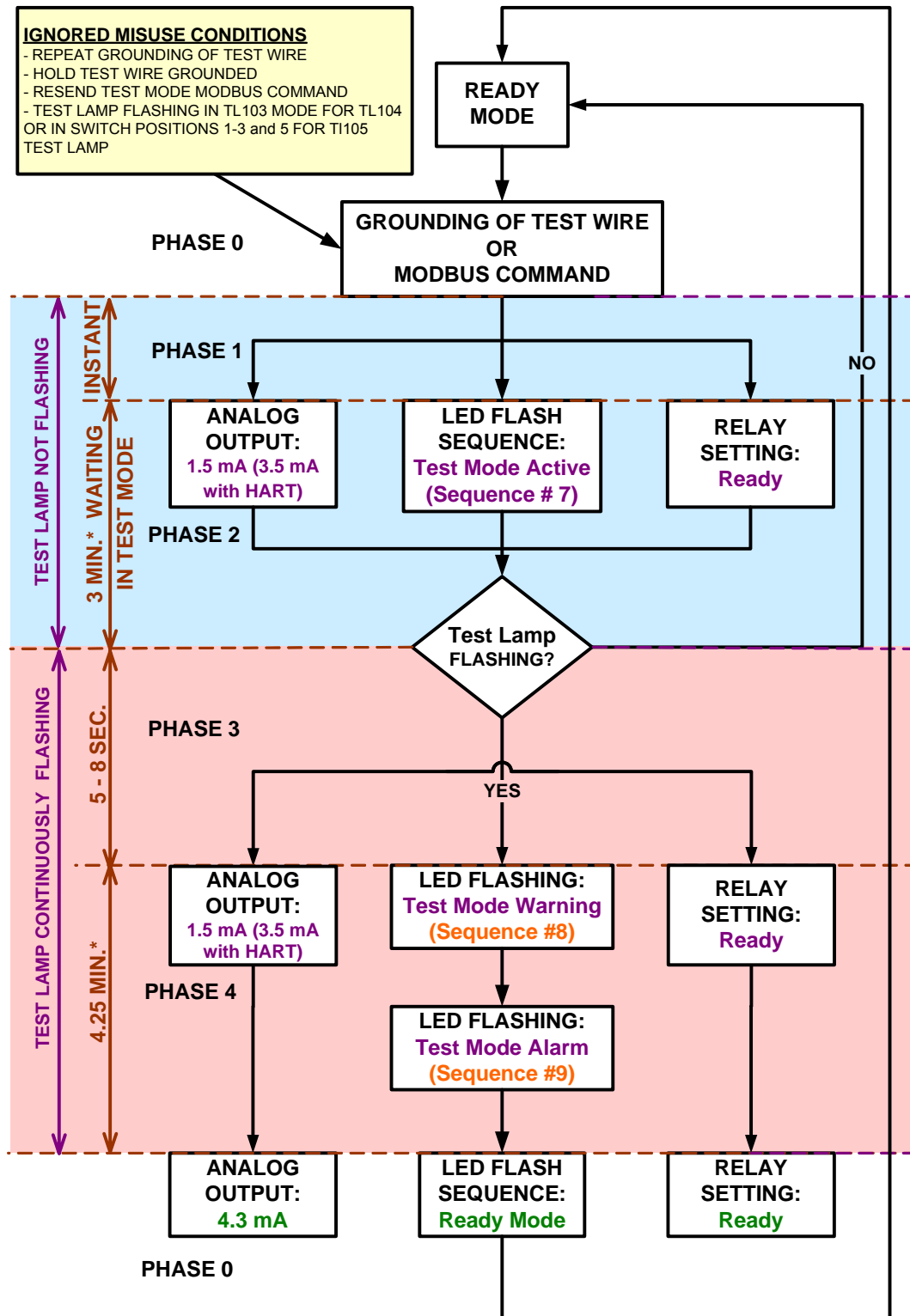

\* FACTORY PROGRAMMABLE

Figure 8: Grounding of Test Wire or Modbus Command Options

## 3.0 Installation



**CAUTION:** The FL4000H contains components that can be damaged by static electricity. Always wear grounding apparel when handling or installing the unit.

**NOTE:** Only personnel trained and qualified in the HART communication protocol may install and use the HART configuration of the FL4000H detector.

**NOTE:** Only trained and authorized users can configure the FL4000H.

**NOTE:** The FL4000H flame detector is to be installed in accordance with NFPA 72 requirements.

The basic steps in a typical installation are listed in the sections below. The installation process may vary depending on the exact site configuration.

**NOTE:** When used with ULC-listed fire alarm control units equipped with 4-wire smoke detector circuits, the FL4000H should be reset by temporarily removing the supply voltage for at least 70 ms with a decline of operation voltage of no less than 3 VDC.

### 3.1 Unpacking the Equipment

All equipment shipped by General Monitors is packaged in shock absorbing containers that protect against physical damage. The contents should be carefully removed and checked against the enclosed packing list.

If any damage has occurred or there is any discrepancy in the order, please contact General Monitors. Refer to Section 7.0 for contact information.

**NOTE:** Each FL4000H is completely tested at the factory; however, a system check is required upon initial start-up to guarantee system integrity.

### 3.2 Required Tools

The following tools are required to install the FL4000H:

**Table 4: Required Tools**

<b>Tool</b>	<b>Use</b>
<b>5mm Allen wrench</b>	To fasten/remove front assembly from base(included)
<b>Flat-head screwdriver 3/16 inch (5 mm) maximum</b>	To connect wires into the Terminal Block (included)
<b>Adjustable wrench</b>	To make conduit and cable gland connections (not included)

### 3.3 Detector Location Guidelines

Several variables are involved in selecting locations to install detectors. There are no hard and fast rules defining the optimum location to ensure proper flame detection. However, the following general suggestions should be considered in regard to particular conditions at the site where the unit(s) is being installed:

#### 3.3.1 Detector Field of View

Each FL4000H Flame Detector has a maximum range of 210 feet (64 m). The FOV<sup>5</sup> has its vertex at the center of the detector. Horizontal FOV is measured in the horizontal plane going through the center axis of the detector, and vertical FOV is measured in the vertical plane going through the same axis. Both horizontal and vertical FOV are defined for high, medium and low sensitivity settings of the FL4000H, as shown in Figure 9 through Figure 14.

**Table 5: Maximum Specified Fields of View at High Sensitivity<sup>6</sup>**

Field of View: Horizontal		Field of View: Vertical	
Max. Specified Range	Max Specified FOV	Max Specified Range	Max Specified FOV
210 ft (64 m)	90°	230 ft (70 m)	75°
100 ft (31 m)	100°	100 ft (30 m)	80°
30 ft (9 m)	90°	30 ft (9 m)	90°

<sup>5</sup> *Maximum specified FOV* is the angle at which FL4000H can detect the flame at 50% of the maximum specified range.

<sup>6</sup> *Maximum specified FOV* is the angle at which FL4000H can detect the flame at 50% of the maximum specified range.

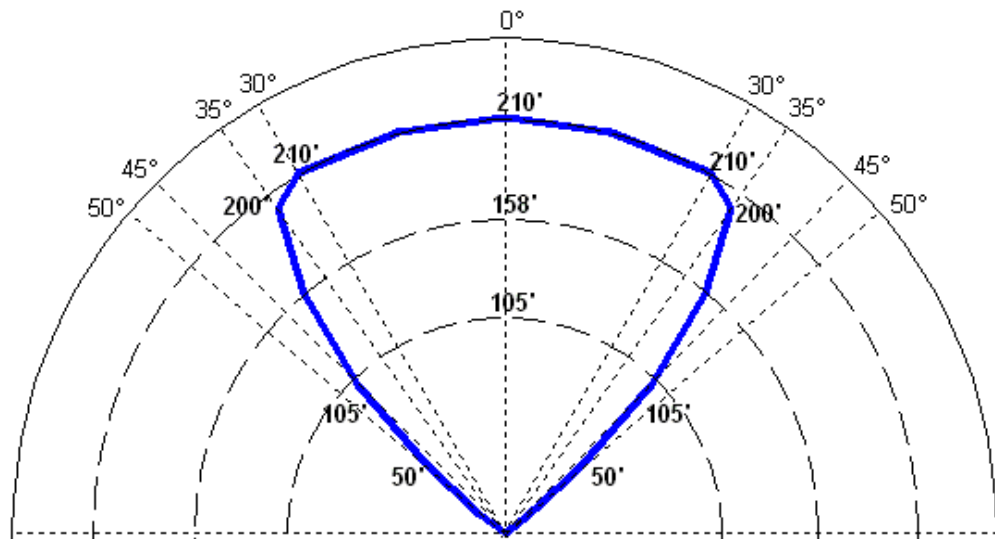

Figure 9: Horizontal FOV – *n*-Heptane – High Sensitivity.

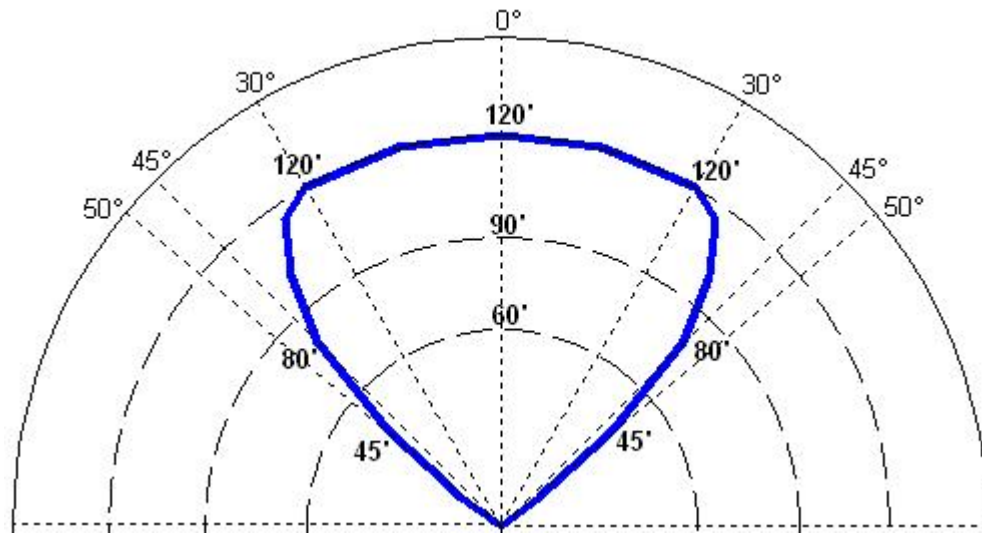
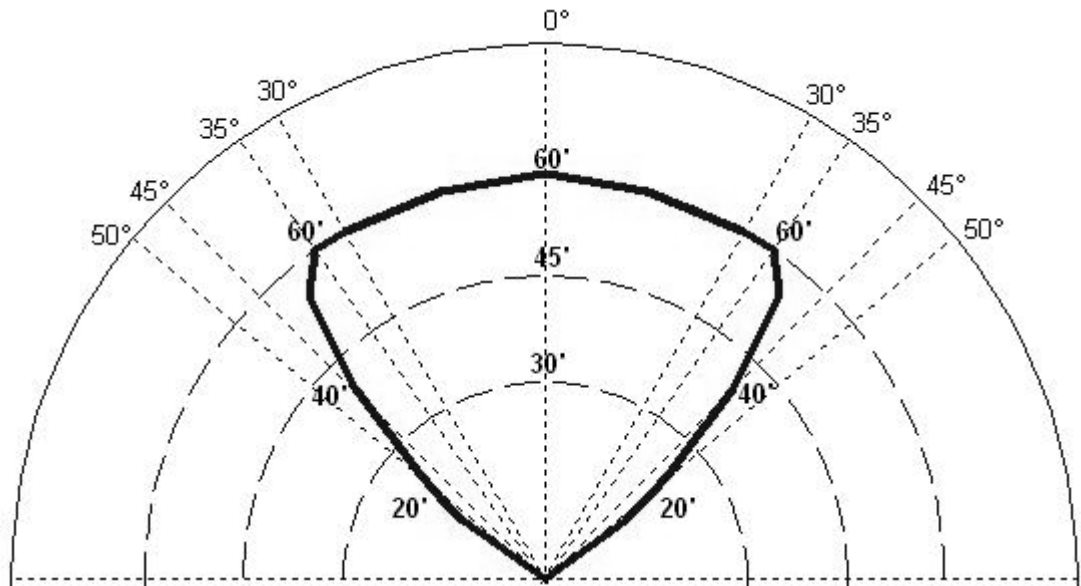
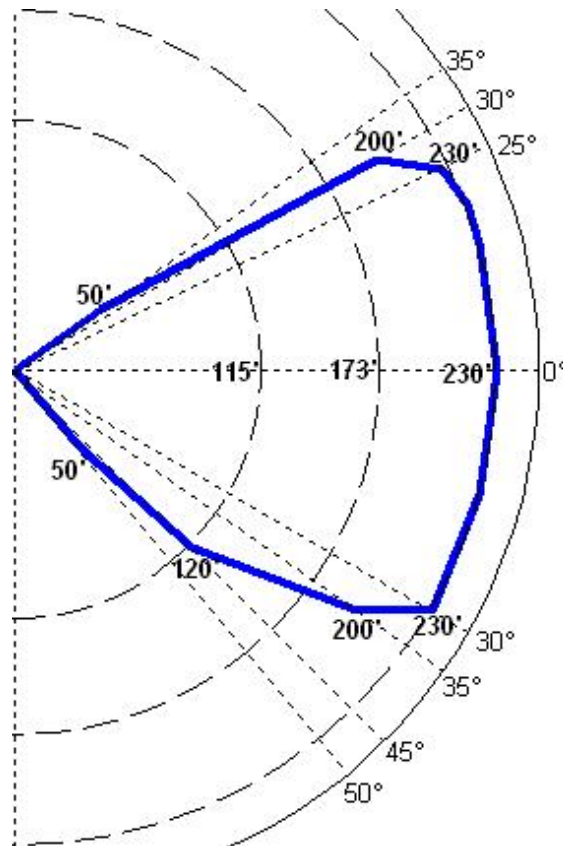

Figure 10: Horizontal FOV – *n*-Heptane – Medium Sensitivity.



**Figure 11: Horizontal FOV – *n*-Heptane – Low Sensitivity.**



**Figure 12: Vertical FOV – *n*-Heptane – High Sensitivity.**

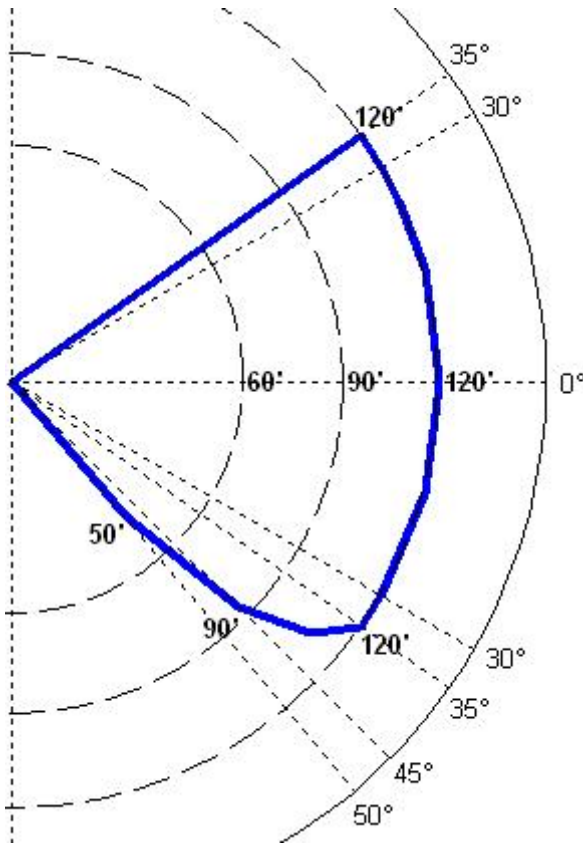

Figure 13: Vertical FOV – *n*-Heptane – Medium Sensitivity.

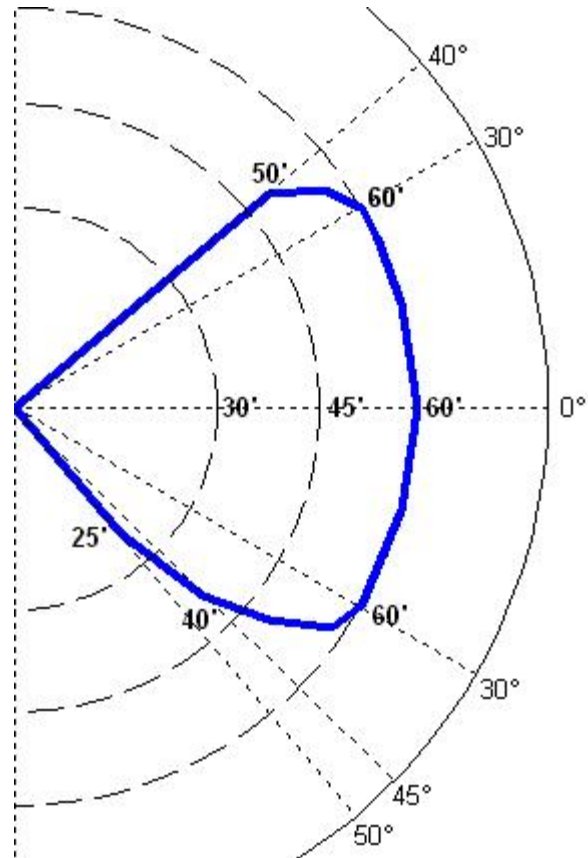

Figure 14: Vertical FOV – *n*-Heptane – Low Sensitivity.

### 3.3.2 Optical Sensitivity Range

The distance at which the detector will respond to a flame is a function of the intensity of that flame. The maximum distance is 210 ft (64.0 m) for an *n*-heptane fire with a surface area of 1 ft<sup>2</sup> (0.092 m<sup>2</sup>). The following table shows the specified ranges for a given sensitivity setting.

Table 6: Sensitivity Settings for *n*-Heptane

Sensitivity Setting	Specified Range ft (m)
Low	60 (18)
Medium	120 (37)
High	210 (64)

### 3.3.3 Environmental Factors

- Observe the ambient temperature range for the specific model – refer to Environmental Specifications (Section 8.2.4). For outdoor installations or other areas exposed to intense, direct solar radiation, the detector may reach temperatures well above specifications. For this condition, a cover for shade may be required to bring the detector temperature within specifications. As with any cover or object near-by, make sure the field of view of the detector is not obstructed.
- Avoid conditions of ice build up on the optical detector windows. Complete icing-over of the IR detector window can result in fault conditions.
- Modulated reflected sunlight shining at the face of the FL4000H reduces flame detection distance.

### 3.4 Field Wiring Procedure

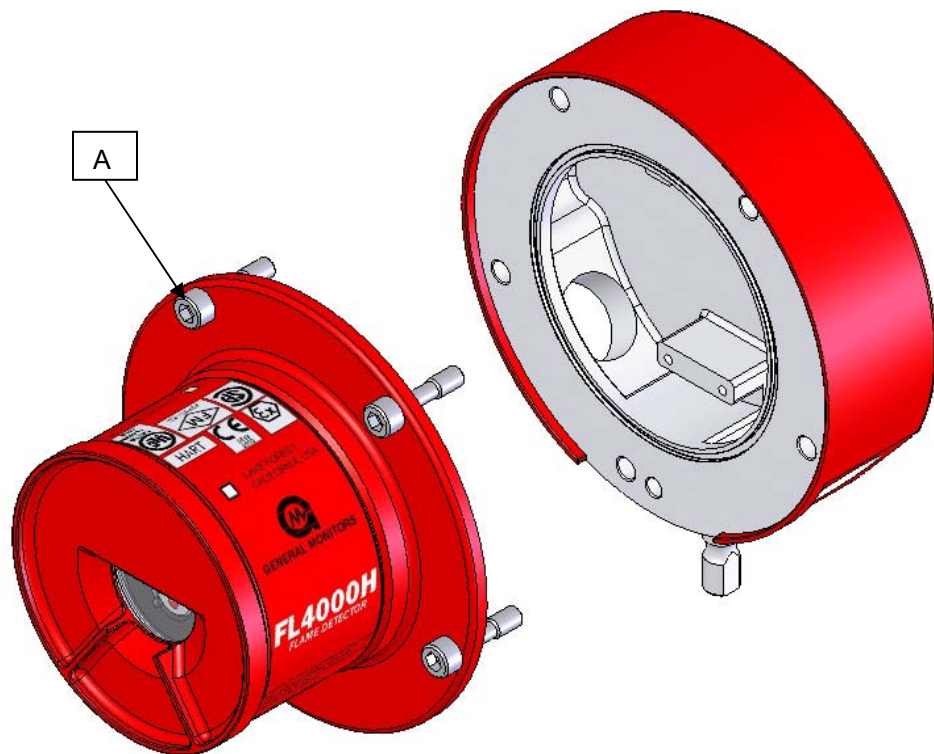

Figure 15: FL4000H Housing

The following procedure should be used in conjunction with Figure 15:

1. Loosen the captive screws (A) located on the Optical Housing Assy.
2. Pull the Optical Housing Assy from the Base Housing Assy to separate, gently rock from side to side if necessary to loosen the connector's grip.
3. Make all necessary wiring connections as described in Sections 3.6.1 thru 3.6.12. For an example of wiring, please refer to the connection diagram in Figure 5.
4. Set switch selectable options as described in Section 3.7 .
5. Reassemble the unit using steps 1 thru 2 in reverse.



**CAUTION:** Do not unscrew the field wiring board from the base housing assembly for wiring.

### 3.5 Detector Mounting and Installation

The FL4000H is enclosed in an explosion proof assembly, which is rated for use in the environments specified in Section 8.3.2.

- The unit should be mounted free from shock and vibration and convenient for visual inspection and cleaning.
- The detector(s) should be tilted downward so that dust or moisture does not accumulate on the sapphire window.
- The detector(s) should be mounted in locations, which will inhibit people or objects from obscuring the detector's FOV.

---

**NOTE:** Frequent inspection, cleaning, and sensitivity checking is suggested for detectors mounted in dirty environments.

---



**CAUTION:** General Monitors requires that the FL4000H conduit entry be sealed per the Canadian Electrical Code Handbook (Part 1, Section 18-154). Conduit seals or approved EExd glands prevent water from entering the detector's housing through the conduit entry. Water entering the housing through the conduit entry will damage the electronics and nullify the warranty.

The FL4000H is mounted as shown in Figure 16 and the overall product dimensions are depicted in Figure 17.

---

**NOTE:** Conduit seal must be within 18" of unit.

**NOTE:** Non-hardening thread sealant should be used if the plugs are removed or re-installed in order to preserve ingress protection rating.

---

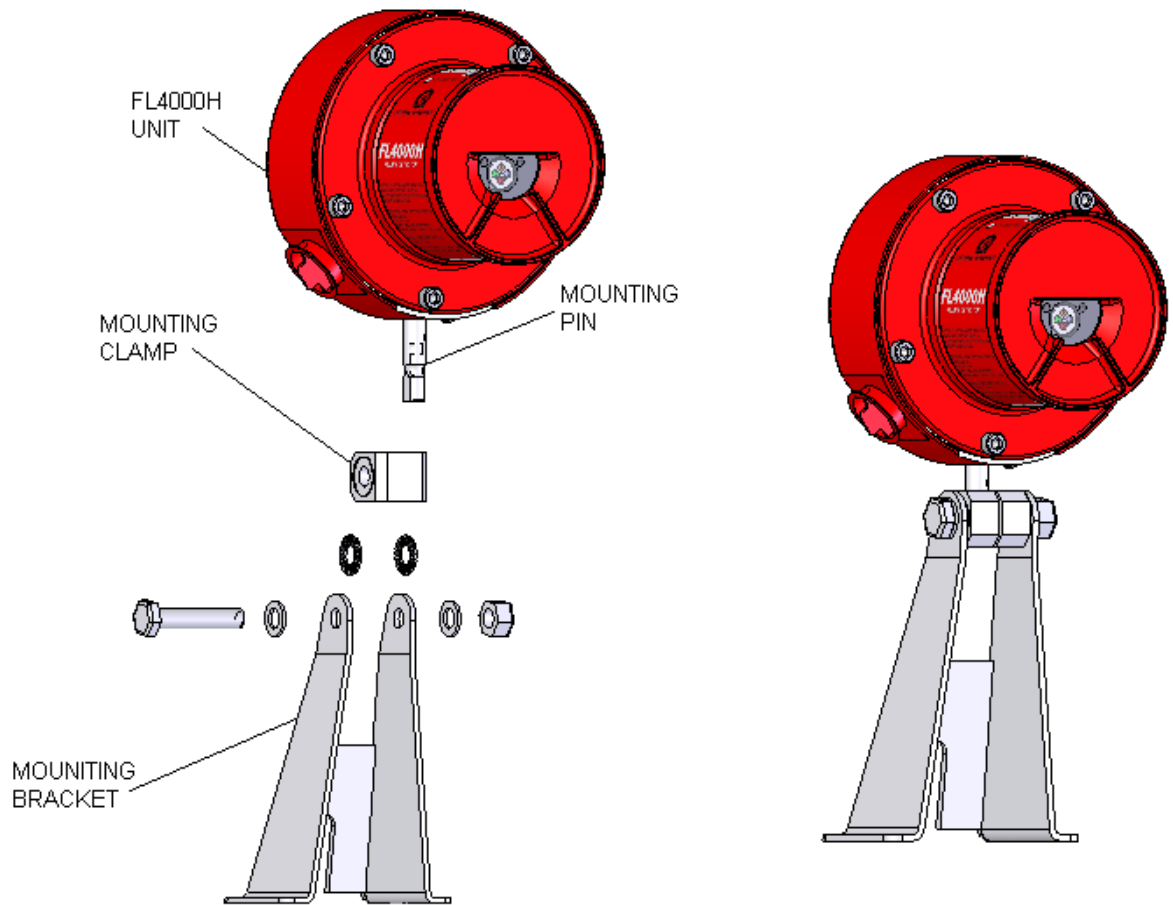

Figure 16: Detector Mounting and Installation

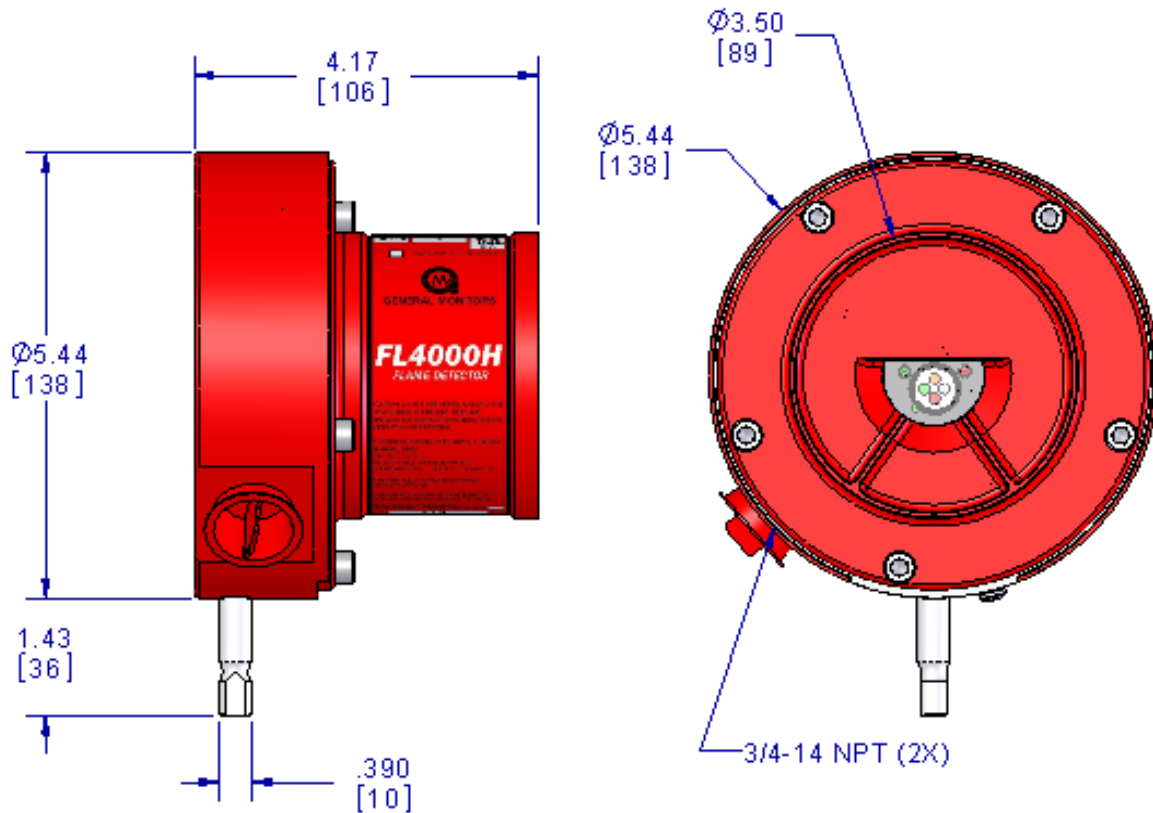

Figure 17: Dimensional Drawing

### 3.6 Terminal Connections

All wire connections are made through the 3/4 inch (1.9 cm) NPT openings in the Junction Module (C, Figure 15) to the Terminal Block. The Terminal Block is located on the Junction Module Assembly (F) and accepts 14 AWG (2.08 mm<sup>2</sup>) to 22 AWG (0.33 mm<sup>2</sup>) stranded or solid-core wire. Each wire should be stripped as shown in Figure 18.

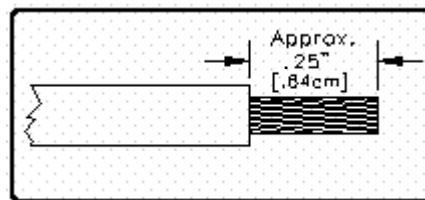
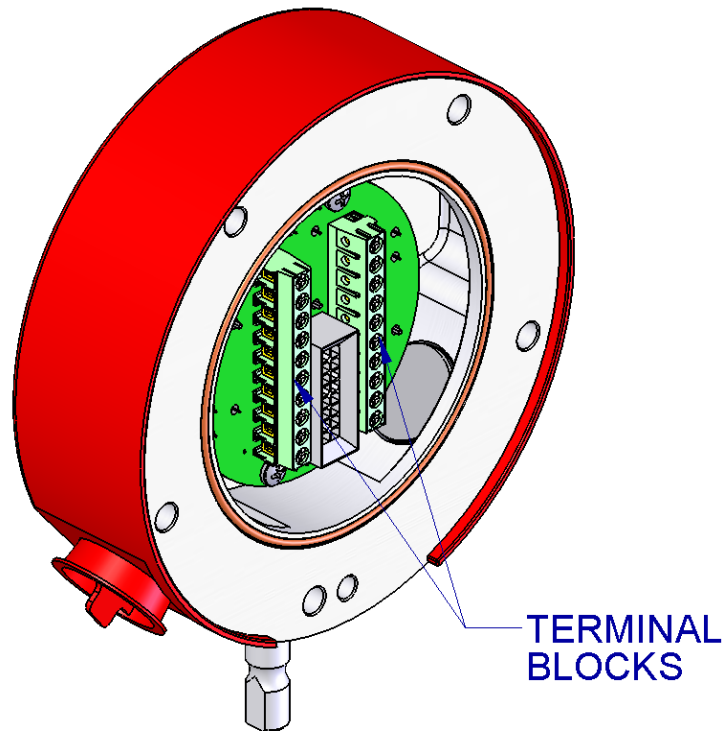

Figure 18: Wire-Strip Lengths

To connect the wire to the Terminal Block, insert the conductor into the connection space (Figure 20) and tighten the corresponding screw terminal.



**Figure 19: Base Housing and Terminal Blocks**

**Table 7: Terminal Block Connections**

Terminal Block – P2	
Pin #	Description
1	CAL_ IO
2	COM2-/DATA2-
3	COM2+/DATA2+
4	RLY_10 (Relay Reset)
5	ALM 2
6	ALM 1
7	ALM C
8	WARN C
9	WARN 1
10	WARN 2

Terminal Block – P1	
Pin #	Description
10	CHGND/CHASGND (Chassis Ground)
9	GND/COM
8	+24 V <sub>in</sub>
7	0-20mA
6	COM1-/DATA1-
5	COM1+/DATA1+
4	TEST_10 (Test Mode)
3	FLT C
2	FLT 1
1	FLT 2

There are twenty possible terminal connections.

Sections 3.6.1, 3.6.2, and 3.6.4 provide a description and specification for each connection.

### 3.6.1 Alarm Relay

**Table 8: Alarm Relay Terminals**

Terminal Block	Connection Point	Block Name	User Relay Settings	
			Normally De-energized	Normally Energized
P2	Term 5	ALM2	Alarm NO	Alarm NC
P2	Term 6	ALM1	Alarm NC	Alarm NO
P2	Term 7	ALMC	Alarm Common	Alarm Common

**NOTE:** NO = Normally Open; NC = Normally Closed

Description: The connections are to the single pole, double throw (SPDT) ALARM relay. ALARM output is time delayed for 0, 8, 10, or 14 seconds. This time delay can be set by Modbus (RS-485) or the user selectable dipswitch (Section 3.7 ). Note that a minimum time delay of 8 seconds can be applied if the flame source is removed within 50% of set delay time from the start of flame. Please refer to Sec.3.7.1. If set via Modbus below 8 seconds, the detector may go into alarm even if the flame source is removed within 50% of the delay time.

The ALARM output can be normally energized or de-energized, latching or non-latching, and these options are also set via Modbus or by a dipswitch. The ALARM relay contact ratings are 8 A @ 250 VAC and 8 A @ 30 VDC. Refer to Figure 20 for all relay connections.

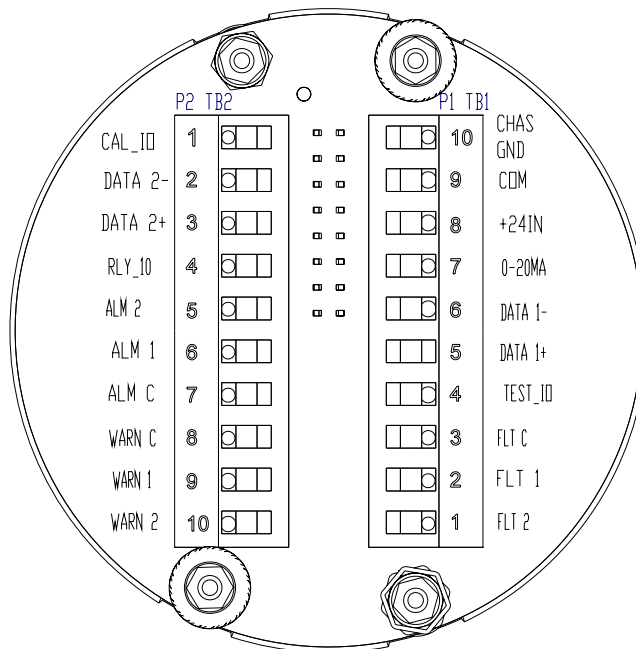

**Figure 20: Terminal Connections<sup>7</sup>**

<sup>7</sup> For ULC-recommended wiring, please see Figure 5.

### 3.6.2 Warning Relay

Table 9: Warning Relay Terminals

Terminal Block	Connection Point	Block Name	User Relay Settings	
			Normally De-energized	Normally Energized
P2	Term 8	WARNC	Warn Common	Warn Common
P2	Term 9	WARN1	Warn NC	Warn NO
P2	Term 10	WARN2	Warn NO	Warn NC

**NOTE:** NO = Normally Open; NC = Normally Closed

Description: These connections are to the SPDT WARN relay. The WARN output is immediate on the FL4000H. The WARN output can be normally energized or de-energized, latching, or non-latching. These options are also set via Modbus or by a dipswitch (Section 3.7 ). The WARN relay contact ratings are 8 A @ 250 VAC and 8 A @ 30 VDC.

Refer to Figure 20 for all relay connections.

### 3.6.3 Alarm Wiring Relay Protection

Inductive loads (bells, buzzers, relay, contractors, solenoid valves, etc.) connected to the Alarm, Warn, and Fault relays must be clamped down as shown on diagrams in Figure 21. Unclamped inductive loads can generate voltage spikes in excess of 1000 volts. Spikes of this magnitude will cause false alarms and possible damage.

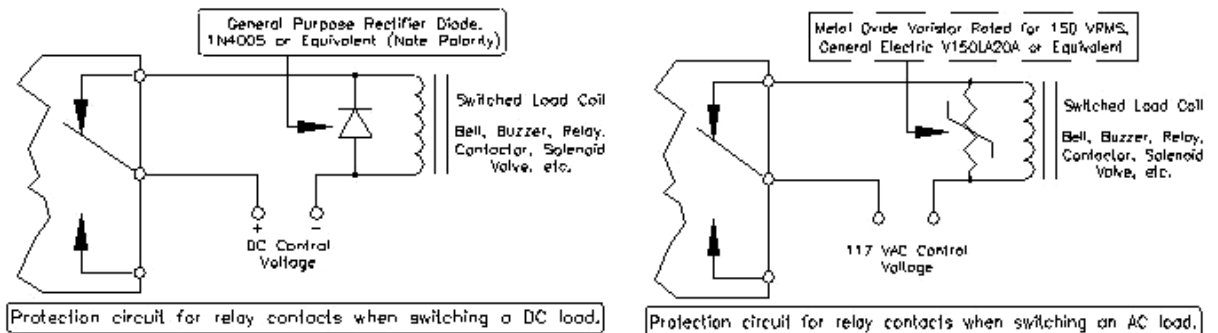

Figure 21: Relay Contacts

Refer to Figure 20 for all relay connections.

### 3.6.4 Fault Relay

**Table 10: Fault Relay Terminals**

Terminal Block	Connection Point	Block Name	Normally Energized
P1	Term 1	FLT2	Fault NC
P1	Term 2	FLT1	Fault NO
P1	Term 3	FLTC	Fault Common

**NOTE:** NO = Normally Open; NC = Normally Closed

Description: These connections are to the SPDT FAULT relay. The FAULT output configuration is normally energized and non-latching. This is the standard output configuration and it cannot be changed.

The FAULT circuit will be activated during the time-out function, a low power or loss of power condition, or during a failed COPM check. During these conditions, the FAULT relays will de-energize and the analog output signal will drop to 0 mA (2 mA for COPM Faults and 3.5 mA with HART) for the duration of the FAULT. The FAULT relay contact ratings are 8 A @ 250 VAC and 8 A @ 30 VDC.

Refer to Figure 20 for all relay connections.

### 3.6.5 Alarm Reset Terminal

**Table 11: Alarm Reset Terminal**

Terminal Block	Connection Point	Block Name	Setting
P2	Term 4	RLY_IO	Relay Reset

The RESET, when activated, returns a latched ALARM and/or WARN output that is no longer valid to its original state. For this RESET function, place one contact of a SPST (single pole, single throw), normally open, momentary switch to P2 Terminal 4 and the other contact to P1 terminal 9 (GND). To activate, press and release the switch.

### 3.6.6 Test Mode Terminal

**Table 12: Test Mode Terminal**

Terminal Block	Connection Point	Block Name	Setting
P1	Term 4	TEST_IO	Test Mode

By connecting one contact of a SPST, normally open, momentary switch to P1 terminal 4 and the other contact to P1 terminal 9 (GND), the user can put the unit into a special test mode. When the switch is first closed, the mode is set and the FL4000H goes to 1.5 mA and 3.5 mA with HART (ready mode) and remains at this value while detecting the Test Lamp. The relays are not activated. Closing the switch a second time or after approximately 3 minutes, the unit will return to normal operation.

**NOTE:** When in test mode via ground wire, the Test Lamp triggers a “ready” condition only.

### 3.6.7 Alarm Test Terminals

**Table 13: Alarm Test Terminals**

Terminal Block	Connection Point	Block Name	Setting
P1	Term 4	TEST_IO	Test Mode
P2	Term 4	RLY_IO	Relay Reset

By connecting one contact of a DPST, normally open, momentary switch to each of the P1 terminal 4 and P2 terminal 4 simultaneously and the other contact to (GND), the user can perform an Alarm Test (Figure 22). Activating this switch for 0 to 14 seconds, depending on the alarm time delay settings, can test the alarm outputs of the Flame Detector. The Alarm Test will activate the WARN and ALARM relay outputs as well as the appropriate analog output. The Flame Detector will remain in this state until the switch is released or until 3 minutes has elapsed.

**NOTE:** The latching WARN and / or ALARM will have to be reset manually.

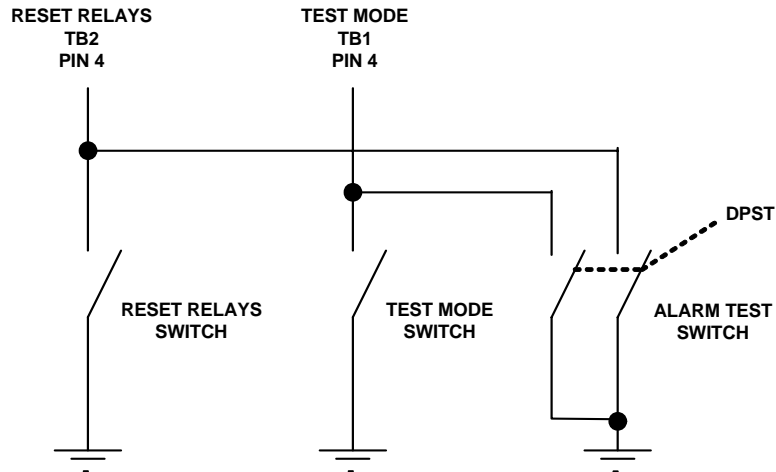

NOTE: ALL SWITCHES ARE MOMENTARY ON

**Figure 22: Wiring Diagram – Reset Relays, Test Mode, & Alarm Test**

### 3.6.8 Analog Output

**Table 14: Analog Output Terminal**

Terminal Block	Connection Point	Block Name	Setting
P1	Term 7	0 – 20 mA	Analog Output

The 0 to 20 mA output is a current signal that corresponds to the following:

**Table 15: Analog Output Levels**

Analog Output	Dual Modbus	HART
Startup <sup>8</sup>	0 to 0.2 mA	3.5 mA
FAULT Signal	0 to 0.2 mA	3.5 mA
Test Mode	1.5 ± 0.2 mA	3.5 mA
COPM Fault Signal	2.0 ± 0.2 mA	3.5 mA
Ready signal	4.3 ± 0.2 mA	4.3 ± 0.2 mA
WARN signal	16.0 ± 0.2 mA	16.0 ± 0.2 mA
ALARM signal	20.0 ± 0.2 mA	20.0 ± 0.2 mA

The maximum analog output load is 600 Ω.

**NOTE:** The COPM Fault Signal may also be set to 0 mA at the factory (non HART only).

### 3.6.9 Cable Requirements

For interfacing with 250 Ω input impedance devices, the following maximum cable lengths apply (maximum 50 Ω loop):

**Table 16: Maximum Cable Lengths for 250 Ω Inputs**

AWG	Feet	Meters
14	9,000	2,750
16	5,800	1,770
18	3,800	1,160
20	2,400	730
22	1,700	520

### 3.6.10 Power

**Table 17: Power Terminals**

Terminal Block	Connection Point	Block Name	Setting
P1	Term 8	+24IN	+24 V <sub>In</sub> (VDC)
P1	Term 9	GND	Ground (COM)

Table 17 shows the power connections for the FL4000H. The supply voltage range is 20 to 36 VDC at the detector (low voltage is detected at 18.5 VDC). The following maximum cable lengths apply for a +24 VDC supply (maximum 20 Ω loop):

**Table 18: Maximum Cable Lengths for +24 VDC**

AWG	Feet	Meters
14	4,500	1,370
16	2,340	715
18	1,540	470
20	970	300
22	670	205

<sup>8</sup> Startup mode lasts exactly 15 seconds.

### 3.6.11 Modbus (RS-485) Output

**Table 19: Modbus Terminals**

Terminal Block	Connection Point	Setting
P1	Term 5	COM1+ (A)
P1	Term 6	COM1- (B)
P2	Term 2	COM2- (B)
P2	Term 3	COM2+ (A)

The connections for the Modbus output are shown in Table 19. The Modbus connection is used to either query the unit's status or to configure the unit. See Section 4.0 for detailed information on Modbus protocol.

### 3.6.12 Chassis Ground

**Table 20: Chassis Ground Terminal**

Terminal Block	Connection Point	Block Name	Setting
P1	Term 10	CHGND	Chassis Ground

For proper operation of the detector, the FL4000H must be grounded through a wire to the chassis. Table 20 shows the terminal block and connection point for the chassis ground terminal. Failure to establish a ground connection can lead to greater susceptibility of the detector to electric surges, electromagnetic interference, and ultimately, damage to the instrument.

## 3.7 Switch Selectable Options

All settings on the FL4000H are selected via a dipswitch on the Power/Relay board or via Modbus (overrides switch settings). To set these options, remove the detector head from the Base Assembly and locate the dipswitch (Figure 23). On the dipswitch, ON/CLOSED means the switch is pushed in on the side labeled ON or CLOSED (opposite the OPEN side). OFF/OPEN means the switch is pushed in on the side with the number corresponding to the switch position or the side labeled OPEN – refer to Table 21 for dipswitch assignments. The settings for the WARN and ALARM outputs are covered in Section 3.6

### 3.7.1 Time Delay Settings

Time delay set via dipswitch guarantees that FL4000H will not go into ALARM mode (20 mA) if the flame source is removed within 50% of set delay time from the start of flame. The unit will always go into WARN mode (16 mA) upon seeing a flame source.

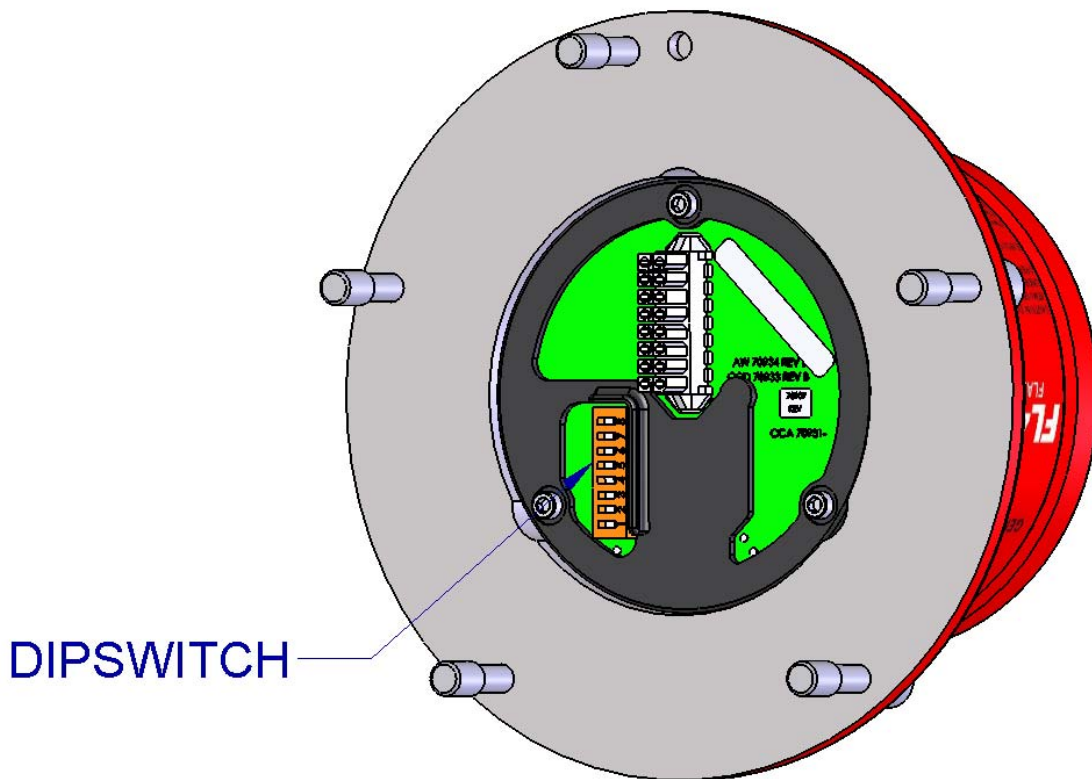

**Figure 23: Dipswitch Location**

**Table 21: Dipswitch Options**

#	Option	On/Closed	Off/Open
1	High Sensitivity		1 and 2
2	Medium Sensitivity	1	2
3	Low Sensitivity	2	1
4	0-Second Alarm Time Delay	3 and 4	
5	8-Second Alarm Time Delay	4	3
6	10-Second Alarm Time Delay		3 and 4
7	14-Second Alarm Time Delay	3	4
8	ALARM Non-Latching		5
9	ALARM Latching	5	
10	WARN Non-Latching		6
11	WARN Latching	6	
12	ALARM Normally Energized	7	
13	ALARM Normally De-Energized		7
14	WARN Normally Energized	8	
15	WARN Normally De-Energized		8

### **3.8 Powering of the FL4000H**

After connecting to a 24 VDC power source, the unit will go through a power up delay of approximately 15 seconds. The LEDs will blink in alternating red – green sequence, the unit will output an analog signal of 0mA (3.5 mA with HART) and the fault relay will be in the de-energized state. If the unit is configured with relays energized, the relays will de-energize for approximately 0.5 seconds. Upon completion of the power on sequence, the green LED will alternate - on for 5 seconds and off for 0.5 seconds to indicate a READY status.

### **3.9 Power up Grounding of the Test and Relay Reset Lines**

During power up, grounding the reset relay line for approximately 1 second forces the Modbus parameters on both channels to go to their default values of: 19,200 Baud, 8-N-1 format, and Unit ID = 1.

During power up, grounding the test line for approximately 1 second forces the unit to use the dipswitch settings rather than use the settings stored in the flash memory. These settings are for the energized/de-energized relay state, the alarm delay, and the unit sensitivity.

## 4.0 Modbus Interface

### 4.1 Introduction

The FL4000H provides communicating ability via the industry standard Modbus protocol, while acting as the slave device in a typical master/slave configuration. Upon receiving an appropriate query from the master, the FL4000H will respond with a formatted message as defined below.

### 4.2 Communication Slave Address

The FL4000H communication slave address is a unique ID used by the Modbus protocol to identify each unit on a multi drop Modbus communication bus. The address may contain the values 1 – 247. There are two communication channels on the FL4000H. Each channel may have a separate slave address. The default slave address for each channel is 1. Register 0x09 is used to modify the address for channel COM1 and register 0x2F is used to modify the address for channel COM2.

### 4.3 Baud Rate

The FL4000H baud rate is selectable using either the Modbus communications interface. The selectable baud rates are 38,400, 19,200, 9,600, 4,800, or 2,400 bits per second (bps). The factory set baud rate is 19,200 bps. Register 0x0B is used to modify the baud rate for comm channel 1 and register 0x30 is used to modify the baud rate for comm channel 2. The selectable baud rates are as follows:

**Table 22: Selectable Baud Rates**

Modbus Register Value	Baud Rate (bps)
04	38,400
03	19,200
02	9,600
01	4,800
00	2,400

### 4.4 Data Format

The data format is selectable using the Modbus communications interface. The factory set data format is 8-N-1. Register 0x0C is used to modify the data format for comm channel 1 and register 0x31 is used to modify the format for comm channel 2. The selectable data formats are as follows:

**Table 23: Selectable Data Formats**

Modbus Register Value	Format	Data Bits	Parity	Stop
00	8-N-1	8	None	1
01	8-E-1	8	Even	1
02	8-O-1	8	Odd	1
03	8-N-2	8	None	2

## 4.5 Supported Function Codes

The FL4000H supports the following function codes:

- Function Code 03 (Read Holding Registers) is used to read status from the slave unit.
- Function Code 06 (Preset Single Register) is used to write a command to the slave unit.

## 4.6 Modbus Read Status Protocol (Query / Response)

A master device reads registers from the FL4000H by sending an 8-byte message (Table 24).

**Table 24: Modbus Read Register(s) Request**

Byte	Modbus	Range	Referenced to FL4000H
1 <sup>st</sup>	Slave Address	1-247* (Decimal)	FL4000H ID (Address)
2 <sup>nd</sup>	Function Code	03	Read Holding Registers
3 <sup>rd</sup>	Starting Address Hi	00	Not Used by the FL4000H
4 <sup>th</sup>	Starting Address Lo	00-44 (Hex)	FL4000H Commands
5 <sup>th</sup>	Number of Registers Hi	00	Not Used by the FL4000H
6 <sup>th</sup>	Number of Registers Lo **	01 – 45 (Hex)	Number of 16 Bit Registers
7 <sup>th</sup>	CRC Lo	00-FF (Hex)	CRC Lo Byte
8 <sup>th</sup>	CRC Hi	00-FF (Hex)	CRC Hi Byte

\* Address 0 is reserved for Broadcast Mode and is not supported at this time.  
 \*\* A maximum of 69 registers can be requested during a single block of time.

Upon receiving a valid read register request from the master device, the FL4000H will respond with a message (Table 25). If the query generates an error, an exception message is returned to the master device (Section 4.8 ).

**Table 25: Modbus Read Register(s) Response**

Byte	Modbus	Range	Referenced to FL4000H
1 <sup>st</sup>	Slave Address	1-247* (Decimal)	FL4000H ID (Address)
2 <sup>nd</sup>	Function Code	03	Read Holding Registers
3 <sup>rd</sup>	Byte Count **	02 – 8A (Hex)	Number of Data Bytes (N <sup>+</sup> )
4 <sup>th</sup>	Data Hi **	00-FF (Hex)	FL4000H Hi Byte Status Data
5 <sup>th</sup>	Data Lo **	00-FF (Hex)	FL4000H Lo Byte Status Data
:	:	:	:
:	:	:	:
N <sup>+</sup> +4	CRC Hi	00-FF (Hex)	CRC Hi Byte
N <sup>+</sup> +5	CRC Lo	00-FF (Hex)	CRC Lo Byte

\* Address 0 is reserved for Broadcast Mode and is not supported at this time.  
 \*\* Byte count and the number of returned data bytes depends on the number of requested registers.  
 + N denotes the number of returned data bytes.

## 4.7 Modbus Write Command Protocol (Query / Response)

A master device writes to a FL4000H register by sending a properly formatted 8-byte message (Table 26).

**Table 26: Modbus Write Register Request**

Byte	Modbus	Range	Referenced to FL4000H
1 <sup>st</sup>	Slave Address	1-247* (Decimal)	FL4000H ID (Address)
2 <sup>nd</sup>	Function Code	06	Preset Single Registers
3 <sup>rd</sup>	Register Address Hi	00	Not Used by FL4000H
4 <sup>th</sup>	Register Address Lo	00-FF (Hex)	FL4000H Register Address Lo Byte
5 <sup>th</sup>	Preset Data Hi	00-03 (Hex)	FL4000H Hi Byte Command Data
6 <sup>th</sup>	Preset Data Lo	00-FF (Hex)	FL4000H Lo Byte Command Data
7 <sup>th</sup>	CRC Hi	00-FF (Hex)	CRC Hi Byte
8 <sup>th</sup>	CRC Lo	00-FF (Hex)	CRC Lo Byte

\* Address 0 is reserved for Broadcast Mode and is not supported at this time.

Upon receiving a valid register write request from the master device, the FL4000H will respond with a message (Table 27). If the write request generates an error, an exception message is returned to the master device (Section 4.8 ).

**Table 27: Modbus Write Register Response**

Byte	Modbus	Range	Referenced to FL4000H
1 <sup>st</sup>	Slave Address	1-247* (Decimal)	FL4000H ID (Address)
2 <sup>nd</sup>	Function Code	06	Preset Single Registers
3 <sup>rd</sup>	Register Address Hi	00	Not Used by FL4000H
4 <sup>th</sup>	Register Address Lo	00-FF (Hex)	FL4000H Register Address Lo Byte
5 <sup>th</sup>	Preset Data Hi	00-FF (Hex)	FL4000H Hi Byte Command Data
6 <sup>th</sup>	Preset Data Lo	00-FF (Hex)	FL4000H Lo Byte Command Data
7 <sup>th</sup>	CRC Hi	00-FF (Hex)	CRC Hi Byte
8 <sup>th</sup>	CRC Lo	00-FF (Hex)	CRC Lo Byte

\* Address 0 is reserved for Broadcast Mode and is not supported at this time.

## 4.8 Exception Responses and Exception Codes

### 4.8.1 Exception Response

In a normal communications query and response, the master device sends a query to the FL4000H. Upon receiving the query, the FL4000H processes the request and returns a response to the master device. An abnormal communication between the two devices produces one of four possible events:

- If the FL4000H does not receive the query due to a communications error, then no response is returned from the FL4000H and the master device will eventually process a timeout condition for the query.
- If the FL4000H receives the query, but detects a communication error (CRC, etc.), then no response is returned from the FL4000H and the master device will eventually process a timeout condition for the query.
- If the FL4000H receives the query without a communications error, but cannot process the response within the master's timeout setting, then no response is returned from the

FL4000H. The master device eventually processes a timeout condition for the query in order to prevent this condition from occurring; the maximum response time for the FL4000H is 200 milliseconds. Therefore, the master's timeout setting should be set to 200 milliseconds or greater.

- If the FL4000H receives the query without a communications error, but cannot process it due to reading or writing to a non-existent FL4000H command register, then the FL4000H returns an exception response message informing the master of the error.

The exception response message has two fields that differentiate it from a normal response. The first is the function code – byte 2. This code will be 0x83 for a read exception and 0x86 for a write exception. The second differentiating field is the exception code – byte 3 (Section 4.8.2). In addition, the total exception response length is 5-bytes rather than the normal message length.

**Table 28: Exception Response**

Byte	Modbus	Range	Referenced to FL4000H
1 <sup>st</sup>	Slave Address	1-247* (Decimal)	FL4000H ID (Address)
2 <sup>nd</sup>	Function Code	83 or 86 (Hex)	Preset Single Registers
3 <sup>rd</sup>	Exception Code	01 – 06 (Hex)	Appropriate Exception Code (See Below)
4 <sup>th</sup>	CRC Hi	00-FF (Hex)	CRC Hi Byte
5 <sup>th</sup>	CRC Lo	00-FF (Hex)	CRC Lo Byte

\* Address 0 is reserved for Broadcast Mode and is not supported at this time.

## 4.8.2 Exception Code

**Exception Code Field:** In a normal response, the FL4000H returns data and status in the response data field. In an exception response, the FL4000H returns an exception code (describing the FL4000H condition) in the data field. Below is a list of exception codes that are supported by the FL4000H:

**Table 29: Exception Codes**

Code	Name	Description
01	Illegal Function	The function code received in the query is not an allowable action for the FL4000H.
02	Illegal Data Address	The data address received in the query is not an allowable address for the FL4000H.
03	Illegal Data Value	A value contained in the query data field is not an allowable value for the FL4000H.
04	Reserved	NA



## 4.9 Command Register Locations

Table 30: Command Register Locations

Register Address (Hex)	Parameter	Function	Data Type	Data Range	Access
0x0000	Analog Output	0-20mA current output	Numeric Value	0-65535 (0-20.0 mA)	R
0x0001	Operating Mode	View operating mode	Numeric Value	Table 31	R
0x0002	Error Status	View present error	Bit Map	Table 32	R
0x0003	Reserved	N/A	N/A	N/A	N/A
0x0004	Model Number	View Model ID	Numeric Value	3500	R
0x0005	Firmware Revision	Firmware Revision ID	2 ASCII chars	1 <sup>st</sup> char is blank, 2 <sup>nd</sup> is: A, B, C, ...	R
0x0006	COPM Fault	Indicates a COPM fault on at least 1 of the detectors	Bit Map	Bit 7 is 1 if any COPM fault, bits 0, 1, 2, 3 indicate sensor id.	R
0x0007	DIP Switch Override	Overrides the DIP Switches at Startup to use Flash Variables	Bit Map	0 = Options read from DIP, 1 means from Flash	R/W
0x0008	Unit Options	Indicates which options are configured	Numeric Value		R/W
0x0009	COM1 Address	Set/view address on Modbus channel 1	Numeric Value	1-247	R/W
0x000A	Reserved	N/A	N/A	N/A	N/A
0x000B	COM1 Baud Rate	Set/view baud rate on Modbus channel 1	Numeric Value	Table 33	R/W
0x000C	COM1 Data Format	Set/view data format on Modbus channel 1	Numeric Value	Table 23	R/W
0x000D	COPM Count Sensor 1	Number of COPM Faults on sensor 1	Numeric Value	0-65535	R
0x000E	COPM Count Sensor 2	Number of COPM Faults on sensor 2	Numeric Value	0-65535	R
0x000F	COPM Count Sensor 3	Number of COPM Faults on sensor 3	Numeric Value	0-65535	R
0x0010	COPM Count Sensor 4	Number of COPM Faults on sensor 4	Numeric Value	0-65535	R
0x0011	Reset Relays	Remotely resets latched alarm & warning relays	Numeric Value	1 = reset relays	W



Register Address (Hex)	Parameter	Function	Data Type	Data Range	Access
0x0012	Remote Alarm Test	Activates Warn & Alarm Relays	Numeric Value	1 = Alarm test, 0 = done test.	R/W
0x0013	Clear COPM Fault Counts	Reset COPM Counters to zero.	Bit Map	Bit 1 = Reset	W
0x0014	Sensor Temperature	Temperature in Degrees C	Numeric Value	-128... +128	R
0x0015 – 0x001F	Reserved	N/A	N/A	N/A	N/A
0x0020	COM1 or COM2 Total Receive Errors	Number of receive errors on user Modbus	Numeric Value	0-65535	R
0x0021	Data Errors	Number of illegal data write errors on user Modbus	Numeric value	0-65535	R
0x0022	Function Code Errors	Number of function code errors on user Modbus	Numeric Value	0-65535	R
0x0023	Starting address errors	Number of starting register address errors	Numeric Value	0-65535	R
0x0024	Total COM1 Only Receive Errors	Total communication errors received on Comm 1	Numeric value	0-65535	R
0x0025	CRC errors LO for serial channel	Number of CRC LO errors on user Modbus channels	Numeric value	0-65535	R
0x0026	CRC errors HI for user serial channel	Number of CRC HI errors on user Modbus channels	Numeric value	0-65535	R
0x0027	Total Overrun Errors COM1 Only	Total Overrun errors received on comm channel 1	Numeric value	0-65535	R
0x0028	Reserved	N/A	N/A	N/A	N/A
0x0029	Total Framing Errors COM1 & COM2	Total Framing errors received on comm channels 1 & 2	Numeric value	0-65535	R
0x002A-0x002C	Reserved	N/A	N/A	N/A	N/A
0x002D	Clear Serial COM Errors	Clear Modbus communication errors	Numeric Value	1	W
0x002F	COM2 Address	Set/view address on Modbus channel 2	Numeric Value	1-247	R/W
0x0030	COM2 Baud Rate	Set/view baud rate on Modbus channel 2	Numeric Value	Table 33	R/W
0x0031	COM2 Data Format	Set/view data format on Modbus channel 2	Numeric Value	Table 34	R/W
0x0032 – 0x003E	Reserved	N/A	N/A	N/A	N/A



Register Address (Hex)	Parameter	Function	Data Type	Data Range	Access
0x003F	Line Voltage	Line input voltage * 10.0	Numeric Value * 10	50 - 360	R
0x0040 – 0x0046	Reserved	N/A	N/A	N/A	N/A
0x0047	Real Time Clock Year, Month	Read/Set year and month of RTC	Numeric Value	1 –99 year, 1– 12 month	R/W
0x0048	Real Time Clock Day, Hour	Read/Set day and hour of RTC	Numeric Value	1 – 31 day, 0 – 23 hour	R/W
0x0049	Real Time Clock Minute, Second	Read/Set minutes and seconds of RTC	Numeric Value	0 – 59 minutes 0 – 59 seconds	R/W
0x004A – 0x0059	Reserved	N/A	N/A	N/A	N/A
0x005A	TEST LAMP Test Mode	Set/Reset TEST LAMP test mode. 0 = Normal Mode. 1 = Test Mode.	Numeric Value	0 - 1	R/W
0x005B	Alarm Delay	Read/Set Alarm Delay	Numeric Value	0 – 30	R/W
0x005C – 0x0090	Reserved	N/A	N/A	N/A	N/A
0x009A	Power Cycled Flag	Time Reset After power Cycled	Numeric Value	0 = Time not Reset, 1 = Time Reset	R
0x009B – 0x009F	Reserved	N/A	N/A	N/A	N/A
0x00A0	Event Index	Index of Logged Events	Numeric Value	0 - 9	R/W
0x00A1	Running Time Hi	Running Time Hi for Warning Event log entries	Numeric Value	0 - 65535	R
0x00A2	Running Time Low	Running Time Low for Warning Event log entries	Numeric Value	0 - 65535	R
0x00A3	Clock Time Hi	Hi byte = year, Lo byte month: Warning clock time	Numeric Value	1 –99 year, 1– 12 month	R
0x00A4	Clock Time Mid	Hi byte = Day, Lo byte Hour: Warning clock time	Numeric Value	1 – 31 day, 0 – 23 hour	R
0x00A5	Clock Time Low	Hi byte = Minute, Lo byte second: Warning clock time	Numeric Value	0 – 59 minutes 0 – 59 seconds	R
0x00A6	Reserved	Reserved	Numeric Value	0	R



Register Address (Hex)	Parameter	Function	Data Type	Data Range	Access
0x00A7	Reserved	Reserved	Numeric Value	0	R
0x00A8	Warning Event Count	Total Warning Event Count	Numeric Value	0 - 65535	R
0x00A9	Running Time Hi	Running Time Hi for Alarm Event log entries	Numeric Value	0 - 65535	R
0x00AA	Running Time Low	Running Time Low for Alarm Event log entries	Numeric Value	0 - 65535	R
0x00AB	Clock Time Hi	Hi byte = year, Lo byte month: Alarm clock time	Numeric Value	1 -99 year, 1- 12 month	R
0x00AC	Clock Time Mid	Hi byte = Day, Lo byte Hour: Alarm clock time	Numeric Value	1 - 31 day, 0 - 23 hour	R
0x00AD	Clock Time Low	Hi byte = Minute, Lo byte second: Alarm clock time	Numeric Value	0 - 59 minutes 0 - 59 seconds	R
0x00AE	Reserved	Reserved	Numeric Value	0	R
0x00AF	Reserved	Reserved	Numeric Value	0	R
0x00B0	Alarm Event Count	Total Alarm Event Count	Numeric Value	0 - 65535	R
0x00B1	Running Time Hi	Running Time Hi for Fault Event log entries	Numeric Value	0 - 65535	R
0x00B2	Running Time Low	Running Time Low for Fault Event log entries	Numeric Value	0 - 65535	R
0x00B3	Clock Time Hi	Hi byte = year, Lo byte month: Fault clock time	Numeric Value	1 -99 year, 1- 12 month	R
0x00B4	Clock Time Mid	Hi byte = Day, Lo byte Hour: Fault clock time	Numeric Value	1 - 31 day, 0 - 23 hour	R
0x00B5	Clock Time Low	Hi byte = Minute, Lo byte second: Fault clock time	Numeric Value	0 - 59 minutes 0 - 59 seconds	R
0x00B6	Fault Code	See Table 32	Numeric Value	0	R
0x00B7	Reserved	Reserved	Numeric Value	0	R
0x00B8	Fault Event Count	Total Fault Event Count	Numeric Value	0 - 65535	R
0x00BA	Running Time Hi	Running Time Hi for Maintenance Event log entries	Numeric Value	0 - 65535	R
0x00BB	Running Time Low	Running Time Low for Maintenance Event log entries	Numeric Value	0 - 65535	R



Register Address (Hex)	Parameter	Function	Data Type	Data Range	Access
0x00BC	Clock Time Hi	Hi byte = year, Lo byte month: Maintenance clock time	Numeric Value	1 –99 year, 1– 12 month	R
0x00BD	Clock Time Mid	Hi byte = Day, Lo byte Hour: Maintenance clock time	Numeric Value	1 – 31 day, 0 – 23 hour	R
0x00BE	Clock Time Low	Hi byte = Minute, Lo byte second: Maintenance clock time	Numeric Value	0 – 59 minutes 0 – 59 seconds	R
0x00BF	Reserved	Reserved	Numeric Value	0	R
0x00C0	Maintenance Event Count	Total Maintenance Event Count	Numeric Value	0 - 65535	R
0x00C1	Reset Event Counter	Reset All Events Counter to 0	Numeric Value	0 - 65535	W

## 4.10 Command Register Details

The following sections provide a detailed description of each user Modbus command register.

### 4.10.1 Analog (0x0000)

A read returns a value, which is proportional to the 0-20 mA output current. The value corresponds to a scaling of 0-65535 decimal.

### 4.10.2 Operating Mode (0x0001)

A read returns the present mode of the FL4000H. A write command changes the mode to the requested mode.

---

**NOTE:** Returns an Exception Code 03 (Illegal Data Value) if an illegal write is requested.

---

Table 31: Status Mode Values

Mode	Decimal Value
Power-Up Delay	1
Warn Non-Latching Only	2
Warn and Alarm Non-latching	3
Warn Latching Only, Alarm Off	4
Alarm Latching Only	5
Warn & Alarm Latching	6
Ready State	7
Alarm Test	10
COPM Fault Detected	11
Warn Latching, Alarm Non-latching, Alarm On	12
TEST LAMP Cycle	13
TEST LAMP Cycle – Fire	14

### 4.10.3 (Register 0x0002) Status/Error

A read returns the errors that are present, which are indicated by bit position. Table 32 shows the error code returned via the Modbus register 2:

**Table 32: Modbus Error Codes**

Function	Bit Position
COPM	3
Low Voltage	4
Data Flash Checksum	6
Code Flash Checksum	7
Relay Reset Shorted	15

**NOTE:** Bits set to “1” when errors occur.

### 4.10.4 Unit Type (0x0004)

A read returns the Modbus identification number for the FL4000H. The identification number for the FL4000H is 3500.

### 4.10.5 Software Revision (0x0005)

A read returns the software revision of the FL4000H as two ASCII characters.

### 4.10.6 COPM Fault (0x0006)

A read returns the type of COPM Fault, which is either due to an obstruction of the window or detector malfunction. Cleaning the window or removing the obstacle can clear a COPM fault caused by a window obstruction.

- Bit 7 is 1 if a COPM fault exists
- Bits 0, 1, 2, or 3 indicate which of the detectors are in Fault

### 4.10.7 Dipswitch Override (0x0007)

A read indicates the status of the dipswitch override bit. A write command changes the state of the bit (Figure 24). When the dipswitch override bit is enabled, the options for the Detector Sensitivity, Relay Delay, Relay Latching/Non-Latching and Relay Energized/De-Energized features are controlled by the data stored in FLASH and are not controlled by the 8-position dipswitch. When the dipswitch override bit is disabled the options are under the control of the 8-position dipswitch. The override bit is located in the LSB of the Low Data Byte and the High Data Byte is not used.

- Bit = 1, Enabled: Configured from FLASH
- Bit = 0, Disabled: Configured from DIP Switch

**NOTE:** By grounding the TEST input during the first 1 second of the power up cycle, the FL4000H will enable the DIP Switch Override, enabling the 8-position Dip Switch settings to take effect. The DIP Switch Override bit will be set to zero after approximately 1 second, at which time this input can be released from ground.

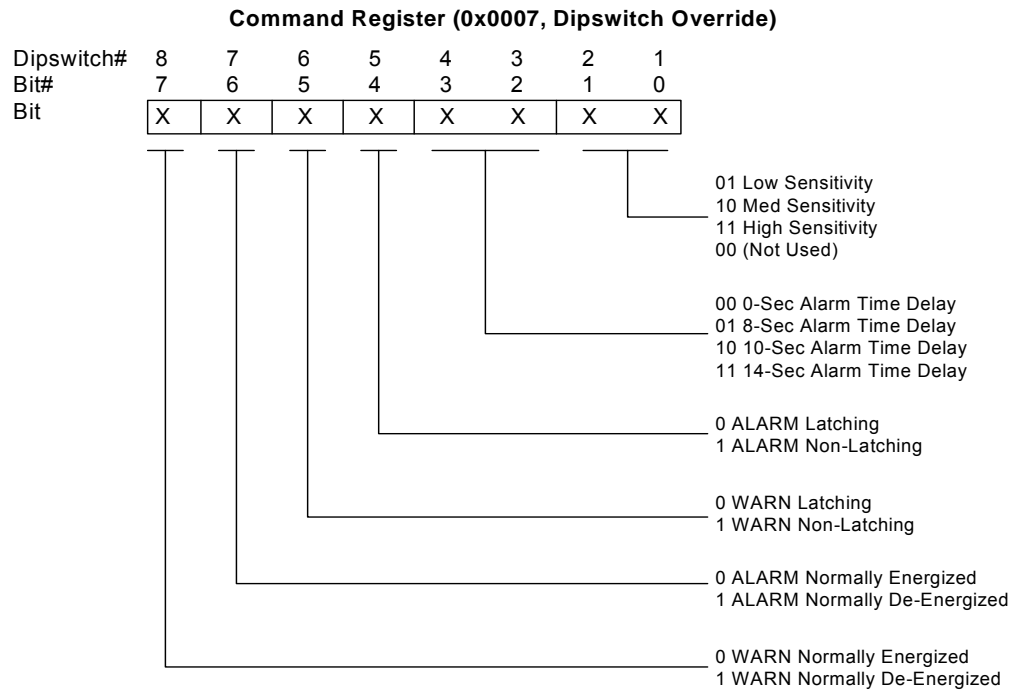

**Figure 24: Command Register**

#### 4.10.8 Options (0x0008)

A read returns the status of the settings for the Detector Sensitivity, Relay Delay, Relay Latching/Non-Latching and Relay Energized/De-Energized features either from the Options dipswitch or the FLASH depending on the setting of the dipswitch override bit listed above. A write command changes the settings for the FLASH only when the dipswitch override bit is enabled. The bits, 0-7 in the register, map directly to the dipswitches 1-8 as shown in Table 21.

**NOTE:** If one writes to register 0x005B, the delay value will be changed, but bits 2 and 3 in register 8 will not be affected. If register 0x0008 is then written to, it will reset register 0x005B if the bits are different from their previous values. If you intend to set the delay through register 0x005B, bits 2 and 3 of register 0x0008 should always be written as 11.

**EXCEPTION:** If an attempt to change the FLASH Options is made while the dipswitch override bit is disabled, then the unit shall return an Exception Code 03 (Illegal Data Value).

#### 4.10.9 COM1 Address (0x0009)

A read command returns the current address for Com1. A write command changes the address to the requested value. Valid addresses are 1-247 decimal. **Factory default is 1.**

**NOTE:** If the address is not in range an Illegal Data Value (03) is returned. By grounding the RESET input during the first 1 second of the power up cycle, the FL4000H Address will default to 1. The address will be set to a default of 1 when the red and green LED's flash alternately after approximately 1 second, at which time the RESET input can be released from ground.

#### 4.10.10 COM1 Baud Rate (0x000B)

A read command returns the current baud rate for COM1 channel. A write command changes the baud rate to the requested values. Valid settings are shown in Table 33. **Factory default is 19,200 baud.**

**Table 33: Com1 Baud Rate**

Baud Rate	Value	Access
2,400	0	Read / Write
4,800	1	Read / Write
9,600	2	Read / Write
19,200	3	Read / Write
38,400	4	Read / Write

**NOTE:** If the baud rate is not in range, an Illegal Data Value (03) is returned. By grounding the RESET input during the first 1 second of the power up cycle, the FL4000H Baud Rate will default to 19.2K. The baud rate will be set to a default of 19.2K when the red and green LED's flash alternately after approximately 1 second, at which time the RESET input can be released from ground.

#### 4.10.11 COM1 Data Format (0x000C)

A read command returns the current data format for COM1 channel. Write command changes the data format to the requested values. Valid settings are shown in Table 34. Default format is 8-N-1.

**Table 34: Selectable Data Formats**

Format	Parity	Stop	Data Bits	Value	Access
8-N-1	None	1	8	0	Read / Write
8-E-1	Even	1	8	1	Read / Write
8-O-1	Odd	1	8	2	Read / Write
8-N-2	None	2	8	3	Read / Write

**NOTE:** If the data format is not in range, an Illegal Data Value (03) is returned. By grounding the RESET input during the first 1 second of the power up cycle, the FL4000H Data Format will default to 8-N-1. The Data Format will be set to a default of 8-N-1 when the red and green LED's flash alternately after approximately 1 second, at which time the RESET input can be released from ground.

#### 4.10.12 COPM Counts Sensor 1 (0x000D)

A read indicates the number of COPM Faults that have occurred for sensor 1 in the FL4000H. Please refer to Section 2.4.2 for more information on COPM and Section 6.0 for troubleshooting tips.

#### 4.10.13 COPM Counts Sensor 2 (0x000E)

A read indicates the number of COPM Faults that have occurred for sensor 2 in the FL4000H. Please refer to Section 2.4.2 for more information on COPM and Section 6.0 for troubleshooting tips.

#### **4.10.14 COPM Counts Sensor 3 (0x000F)**

A read indicates the number of COPM Faults that have occurred for sensor 3 in the FL4000H. Please refer to Section 2.4.2 for more information on COPM and Section 6.0 for troubleshooting tips.

#### **4.10.15 COPM Counts Sensor 4 (0x0010)**

A read indicates the number of COPM Faults that have occurred for sensor 4 in the FL4000H. Please refer to Section 2.4.2 for more information on COPM and Section 6.0 for troubleshooting tips.

#### **4.10.16 Remote Reset (0x0011)**

Writing a 1 to the register activates the Remote Reset function, which resets the Alarm and Warn Relays. The function is active momentarily and will reset automatically after being used.

#### **4.10.17 Remote Alarm Test (0x0012)**

Writing a 1 to the register activates the Remote Alarm Test function, which activates the Warn and Alarm Relays. In addition, the function also activates the corresponding LED sequence and analog output. Upon completion of the test, a zero should be written to the register to conclude the Alarm Test. If the relays are configured in a latching configuration, refer to Section 4.10.16 to reset the relays and the alarm condition.

#### **4.10.18 Clear COPM Faults (0x0013)**

Writing a 1 to the register activates the Clear COPM Faults function that resets all of the detector fault counters.

#### **4.10.19 Sensor Temperature Output (0x0014)**

Reading this register retrieves the sensor temperature in degrees Celsius. The range is –128 to +128.

#### **4.10.20 Total Receive Errors – COM1 or COM2 (0x0020)**

A read indicates the total Modbus COM1 or COM2 channel receive errors in the FL4000H. The maximum count is 65535, after which the counter resets to zero and begins counting anew. The total errors are an accumulation of all communication errors.

#### **4.10.21 Data Errors – COM1 and COM2 (0x0021)**

A read indicates the number of illegal data write errors on user Modbus. These are errors where the write value is out of range. The maximum count is 65535, after which the counter resets to zero and begins counting anew.

#### **4.10.22 COM1 and COM2 Function Code Errors (0x0022)**

A read indicates the total Modbus COM1 & COM2 function code errors that occurred in the slave device. The maximum count is 65535, after which the counter resets to zero and begins counting anew.

#### **4.10.23 Starting Register Address Errors (0x0023)**

A read indicates the number of starting register address errors. The maximum count is 65535, after which the counter resets to zero and begins counting anew.

#### **4.10.24 Total Receive Errors – COM1 only (0x0024)**

A read indicates the total number of Modbus COM1 receive errors in the FL4000H. The maximum count is 65535, after which the counter resets to zero and begins counting anew.

#### **4.10.25 CRC Errors Low – COM1 and COM2 (0x0025)**

A read indicates the total number of COM1 or COM2 CRC low byte errors in the FL4000H. The maximum count is 65535, after which the counter resets to zero and begins counting anew.

#### **4.10.26 CRC Errors Hi – COM1 and COM2 (0x0026)**

A read indicates the number of COM1 and COM2 CRC Hi byte errors that occurred in the FL4000H. The maximum count is 65535, after which the counter resets to zero and begins counting anew.

#### **4.10.27 Total Overrun Errors – COM1 only (0x0027)**

A read indicates the number of COM1 Overrun Errors that occurred in the FL4000H. The maximum count is 65535, after which the counter resets to zero and begins counting anew.

---

**NOTE:** An overrun error occurs when a subsequent received data byte overwrites an earlier unprocessed data byte. As a result, one of the received data bytes will be corrupted.

---

#### **4.10.28 Total Framing Errors – COM1 and COM2 (0x0029)**

A read indicates the number of Comm 1 and Comm 2 Framing Errors that occurred in the FL4000H. The maximum count is 65535, after which the counter resets to zero and begins counting anew.

#### **4.10.29 Clear Communication Errors (0x002D)**

A read indicates the total number of Modbus communication errors. The maximum count is 65535, after which the counter resets to zero and begins counting anew. A write resets this value to 0. Only a write of value "0" is allowed for this register.

#### **4.10.30 COM2 Address (0x002F)**

A read returns the COM2 address of the FL4000H. A write changes the address to the requested number. The range of the address is from 1 to 247 (01 to F7 in Hex). After changing the address of the FL4000H, it will be necessary for the controlling or master device to similarly change its query address in order to once again communicate with the FL4000H.

---

**NOTE:** By grounding the RESET input during the power-up cycle (approximately 10 seconds), the address of the FL4000H will default to 1.

---

#### **4.10.31 COM2 Baud Rate (0x0030)**

A read returns the COM2 baud rate of the FL4000H. A write changes the baud rate to the requested level. After changing the baud rate of the FL4000H, it will be necessary for the controlling or master device to similarly change its own baud rate in order to once again communicate with the FL4000H.

---

**NOTE:** By grounding the RESET input during the power-up cycle (approximately 10 seconds), the baud rate of the FL4000H will default to 19.2K. Valid settings are shown in Table 33

---

#### 4.10.32 COM2 Data Format (0x0031)

A read returns the COM2 data format of the FL4000H. A write changes the data format to the requested format. After changing the data format of the FL4000H, it will be necessary for the controlling or master device to similarly change its own data format in order to once again communicate with the FL4000H.

---

**NOTE:** By grounding the RESET input during the power-up cycle (approximately 10 seconds), the data format of the FL4000H will default to 8-N-1. Valid settings are shown in Table 33.

---

#### 4.10.33 Set/Read Real-time Clock Year, Month (0x0047)

This is used to read/write the real time clock. The high byte will be the year minus 2000. The low byte will be a value from 1 to 12.

#### 4.10.34 Set/Read Real-time Clock Day, Hour (0x0048)

This is used to read/write the real time clock. The high byte will be the day of the month from 1 to 31. The low byte will be the hour from 0 to 23.

#### 4.10.35 Set/Read Real-time Clock Minute, Second (0x0049)

This is used to read/write the real time clock. The high byte will be the minute from 0 to 59 and the low byte will be the seconds from 0 to 59.

---

**NOTE:** The registers when read, should be read in order: first 47, then 48, then 49. When written, they should be written in order: first 47, then 48, and finally 49.

---

#### 4.10.36 Set/Reset TEST LAMP Test Mode (0x005A)

This is used to place the unit into Test Lamp test mode or return it to the normal mode. Writing a 1 to the register places the unit into test mode. Writing a 0 to the register places it back into normal mode. Refer to Section 3.6.6 Test Mode Terminal.

#### 4.10.37 TEST LAMP Alarm Delay (0x005B)

Using the dipswitches, the alarm delay may be set to one of four pre-programmed settings (0, 8, 10, or 14 seconds). Register 0x5B is used to set the alarm delay to any desired value from 0 to 30 seconds. The dipswitch override flag must be set to 1.

---

**NOTE:** If the user writes to this register, it overrides the value set by bits 2 and 3 of register 8. Reading register 8 will simply return the last values in bits 2 and 3 that will not show the value written to this register. This behavior is intentional and is to provide backward compatibility with other General Monitors' flame detectors.

---

#### 4.10.38 Power Cycle Flag (0x009A)

This reads whether the time of day clock has been reset after a power has been re-cycled to the unit. If the time has been reset, this flag will be = 0; otherwise the flag will = 1.

#### 4.10.39 Event Index (0x00A0)

This is used to indicate which of the stored events the user would like to read. There are 4 event logs maintained by the FL4000H unit: Warning events, Alarm events, Fault events, and

Maintenance events. Each of these event logs consist of 10 of their most recent occurrences. The user is able to read the times of each of these by setting this event index followed by a reading of the desired event log. The event index is a number from 0 to 9. Zero refers to the most recent event and 9 refers to the least recent event stored in the log. For example to read the most recent Warning event in the Warning event log, set this register to 0 and then read registers 0xA1 and 0xA2 (for the running time in seconds) or read registers 0xA3, 0xA4, and 0xA5 (for the clock time). There is also a warning counter which gives the total number of warnings received by the system (with a maximum of 65535).

**4.10.40 Warning Running Time in Seconds, Hi Word (0x00A1)**

This register reads the hi word of the running time in seconds when the warning event occurred. This time is in seconds since January 1, 2000. This register should be read before register 0xA2.

**4.10.41 Warning Running Time in Seconds, Low Word (0x00A2)**

This register reads the low word of the running time in seconds when the warning event occurred. This time is in seconds since January 1, 2000. This register should be read only after register 0xA1.

**Table 35: Event Log Clock Time Format**

Item Number	Register	Description
1	A3	Hi Byte =Year, Low Byte = Month
2	A4	Hi Byte = Day, Low Byte = Hour
3	A5	Hi Byte = Minute, Low Byte = Second

The values from the above table should be read in order: first item 1, then item 2, & then item 3.

**4.10.42 Warning Clock Time: Year, Month (0x00A3)**

These registers are described in Table 35 item number 1.

**4.10.43 Warning Clock Time: Day, Hour (0x00A4)**

These registers are described in Table 35 item number 2.

**4.10.44 Warning Clock Time: Minute, Second (0x00A5)**

These registers are described in Table 35 as item number 3.

**4.10.45 Reserved (0x00A6)**

This register returns the value 0.

**4.10.46 Reserved (0x00A7)**

This register returns the value 0.

**4.10.47 Total Warning Event Counter (0x00A8)**

This reads the total number of warning events have been stored in the unit.

**4.10.48 Alarm Running Time in Seconds, Hi Word (0x00A9)**

This register reads the hi word of the running time in seconds when the alarm event occurred. This time is in seconds since January 1, 2000. This register should be read before register 0xAA.

**4.10.49 Alarm Running Time in Seconds, Low Word (0x00AA)**

This register reads the low word of the running time in seconds when the alarm event occurred. This time is in seconds since January 1, 2000. This register should be read only after register 0xA9.

**4.10.50 Alarm Clock Time: Year, Month (0x00AB)**

These registers are described in Table 35 as item number 1.

**4.10.51 Alarm Clock Time: Day, Hour (0x00AC)**

These registers are described in Table 35 as item number 2.

**4.10.52 Alarm Clock Time: Minute, Seconds (0x00AD)**

These registers are described in Table 35 as item number 3.

**4.10.53 Reserved (0x00AE)**

This register returns the value 0.

**4.10.54 Reserved (0x00AF)**

This register returns the value 0.

**4.10.55 Total Alarm Event Counter (0x00B0)**

This reads the total number of alarm events have been stored in the unit.

**4.10.56 Fault Running Time in Seconds, Hi Word (0x00B1)**

This register reads the hi word of the running time in seconds when the fault event occurred. This time is in seconds since January 1, 2000. This register should be read before register 0xB2.

**4.10.57 Fault Running Time in Seconds, Low Word (0x00B2)**

This register reads the low word of the running time in seconds when the fault event occurred. This time is in seconds since January 1, 2000. This register should be read only after register 0xB1.

**4.10.58 Fault Clock Time: Year, Month (0x00B3)**

These registers are described in Table 35 as item number 1.

**4.10.59 Fault Clock Time: Day, Hour (0x00B4)**

These registers are described in Table 35 as item number 2.

**4.10.60 Fault Clock Time: Minute, Seconds (0x00B5)**

These registers are described in Table 35 as item number 3.

**4.10.61 Fault Code (0x00B6)**

This register is described in Table 32.

**4.10.62 Reserved (0x00B7)**

This register returns the value 0.

**4.10.63 Total Fault Event Counter (0x00B8)**

This reads the total number of fault events have been stored in the unit.

**4.10.64 Maintenance Running Time in Seconds, Hi Word (0x00BA)**

This register reads the hi word of the running time in seconds when the maintenance event occurred. This time is in seconds since January 1, 2000. This register should be read before register 0xBB.

**4.10.65 Maintenance Running Time in Seconds, Low Word (0x00BB)**

This register reads the low word of the running time in seconds when the maintenance event occurred. This time is in seconds since January 1, 2000. This register should only be read after register 0xBA.

**4.10.66 Maintenance Clock Time: Year, Month (0x00BC)**

These registers are described in Table 35 as item number 1.

**4.10.67 Maintenance Clock Time: Day, Hour (0x00BD)**

These registers are described in Table 35 as item number 2.

**4.10.68 Maintenance Clock Time: Minute, Seconds (0x00BE)**

These registers are described in Table 35 as item number 3.

**4.10.69 Reserved (0x00BF)**

This register returns the value 0.

**4.10.70 Total Maintenance Event Counter (0x00C0)**

This reads the total number of maintenance events have been stored in the unit.

**4.10.71 Reset All Event Counters (0x00C1)**

Writing to this register resets all event counters to zero.

## 5.0 Maintenance

### 5.1 General Maintenance

Once correctly installed, the unit requires very little maintenance other than regular sensitivity checks and cleaning of the window. General Monitors recommends that a schedule be established and followed. Do not remove the electronics from the housing. Doing so will void the equipment's warranty.

---

**NOTE:** The removal of particulate matter and any film buildup on the Sapphire Window and COPM Reflector is necessary to ensure proper sensitivity of the system. It is recommended that the window and reflector be cleaned at least every 30 days if the detector is located in a particularly dirty environment.

---

### 5.2 Cleaning the Sapphire Window

A clean, soft, lint-free cloth, tissue or cotton swab should be used to apply the cleaning solution. The window is not glass; it is made from sapphire. The cleaning solution should be General Monitors' P/N 10272-1 (Industrial Strength Windex<sup>®</sup> with Ammonia D).

Do not touch the window or COPM reflector with fingers.

1. Wet the window with the solution.
2. Rub with a dry, unsoiled cloth until the window is clean.
3. Completely dry the window.
4. Repeat steps 1, 2 and 3 for the reflector.



**CAUTION:** Dirty or partially blocked windows can significantly reduce the detectors field of view and detection distance. Do not use a commercial glass cleaner other than Industrial Strength Windex<sup>®</sup> with Ammonia D.

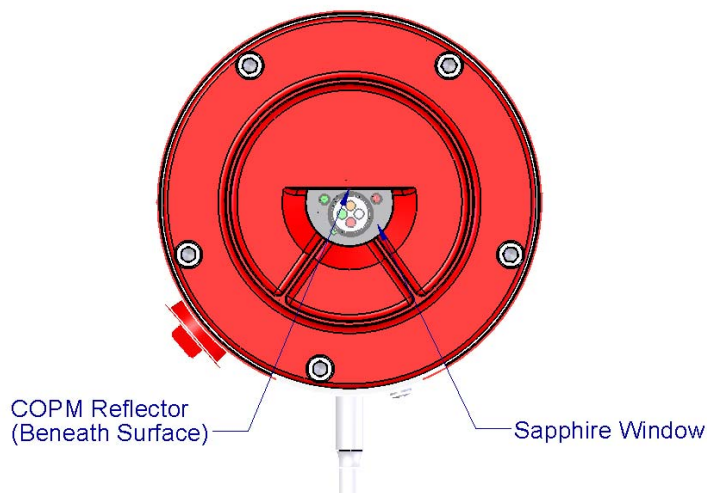

Figure 25: Optical Parts to Clean

### **5.3 Sensitivity Check**

To verify that each detector is functioning correctly, a General Monitors' Test Lamp and/or the ALARM TEST function (Section 3.6.7) should be used. Refer to Section 8.5 for details on Test Lamps.

### **5.4 Storage**

The FL4000H should be stored in a clean, dry area and within the temperature and humidity ranges quoted in Section 8.2.4, Environmental Specifications.

## 6.0 Troubleshooting

### 6.1 Troubleshooting Chart

This section is intended to be a guide to correcting problems, which may arise in the field. General Monitors should be contacted for assistance if the corrective action listed does not eliminate the problem. Defective units should be returned to General Monitors for repair with a complete written description of the problem.

**NOTE:** If the equipment is under warranty, any repairs performed by persons other than General Monitors' authorized personnel may void the warranty. Please read the warranty statement carefully.



**CAUTION:** Be sure to inhibit or disconnect external alarm wiring before making any check that might send the unit into alarm.

**Table 36: Troubleshooting Chart**

<b>PROBLEM</b>	<b>POSSIBLE CAUSE</b>	<b>CORRECTIVE ACTION</b>
Analog output signal = 0 mA and green LED in window is off	No DC power to the Unit	Be sure that the +24 VDC is applied with the correct polarity
Analog output signal = 0 mA (3.5 mA with HART) and green LED in window is rapidly blinking	Low voltage FAULT (voltage at unit is approximately +18.5 VDC)	Be sure that the unit is powered with at least +24 VDC under load
Analog output signal = 0 mA (3.5 mA with HART) and green LED in window is rapidly blinking, +24 VDC verified	Flash Checksum Not OK	Re-cycle power to the unit
Analog output signal = 0 mA (3.5 mA with HART) and green LED in window is rapidly blinking, +24 VDC verified OK, power was re-cycled	Flash Checksum Still Not OK	Call GM customer support
Analog output signal = 2 mA (3.5 mA with HART) and green LED in window is slowly blinking	COPM FAULT, dirty or obscured optical path (detector window)	Clean the window and reflector
Dipswitch settings do not match those observed in the operation of the detector	Device settings may have been changed by either HART or Modbus and no longer correspond to those on the dipswitch	Recycle power to the unit while connecting the test IO terminal to ground (refer to Section 3.9 ). After startup, adjust settings via dipswitch as described in Sec. 3.7 (Switch Selectable Options)

## 6.2 Final Assembly

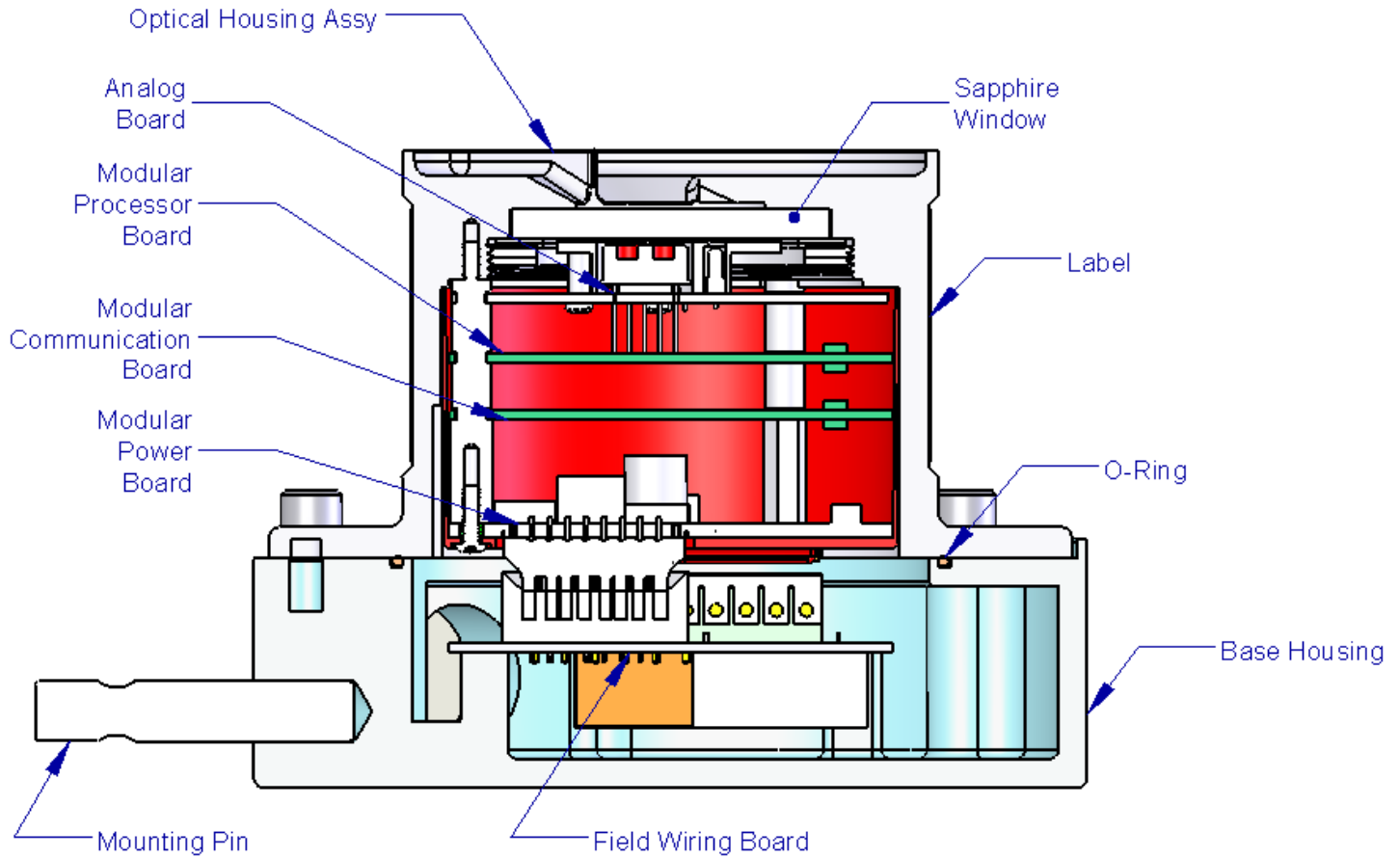

Figure 26: FL4000H Cross-Section View

## 7.0 Customer Support

### 7.1 General Monitors' Offices

**Table 37: GM Locations**

<b>Area</b>	<b>Phone/Fax/Email</b>
<b>UNITED STATES</b>	
Toll Free:	+1-800-446-4872
Corporate Office:	Phone: +1-949-581-4464
26776 Simpatica Circle	Fax: +1-949-581-1151
Lake Forest, CA 92630	Email: <a href="mailto:info@generalmonitors.com">info@generalmonitors.com</a>
9776 Whithorn Drive	Phone: +1-281-855-6000
Houston, TX 77095	Fax: +1-281-855-3290
	Email: <a href="mailto:gmlhou@generalmonitors.com">gmlhou@generalmonitors.com</a>
<b>UNITED KINGDOM</b>	
Heather Close	Phone: +44-1625-619-583
Lyme Green Business Park	Fax: +44-1625-619-098
Macclesfield, Cheshire, United Kingdom, SK11 0LR	Email: <a href="mailto:info@generalmonitors.co.uk">info@generalmonitors.co.uk</a>
<b>IRELAND</b>	
Ballybrit Business Park	Phone: +353-91-751175
Galway	Fax: +353-91-751317
Republic of Ireland	Email: <a href="mailto:info@gmil.ie">info@gmil.ie</a>
<b>SINGAPORE</b>	
No. 2 Kallang Pudding Rd.	Phone: +65-6-748-3488
#09-16 Mactech Building	Fax: +65-6-748-1911
Singapore 349307	Email: <a href="mailto:genmon@gmpacifica.com.sg">genmon@gmpacifica.com.sg</a>
<b>MIDDLE EAST</b>	
JAFZA View Building, 3rd Floor,	Phone: +971-4-814-3814
Office No. 308	Fax: +971-8-448-0051
LOB 18, Jebel Ali Free Zone	Email: <a href="mailto:gmme@generalmonitors.ae">gmme@generalmonitors.ae</a>
P.O. Box 61209	
Dubai, United Arab Emirates	

### 7.2 Other Sources of Help

General Monitors provides extensive documentation, white papers, and product literature for the company's complete line of safety products, many of which can be used in combination with the FL4000H. Many of these documents are available online at the General Monitors website at <http://www.generalmonitors.com>.

## 8.0 Appendix

### 8.1 Warranty

General Monitors warrants the FL4000H to be free from defects in workmanship or material under normal use and service within two (2) years from the date of shipment.

General Monitors will repair or replace without charge any equipment found to be defective during the warranty period. Full determination of the nature of, and responsibility for, defective or damaged equipment will be made by General Monitors' personnel.

Defective or damaged equipment must be shipped prepaid to General Monitors or the representative from which shipment was made. In all cases, this warranty is limited to the cost of the equipment supplied by General Monitors. The customer will assume all liability for the misuse of this equipment by its employees or other personnel.

All warranties are contingent upon proper use in the application for which the product was intended and do not cover products which have been modified or repaired without General Monitors' approval or which have been subjected to neglect, accident, improper installation or application, or on which the original identification marks have been removed or altered.

Except for the express warranty stated above, General Monitors disclaims all warranties with regard to the products sold, including all implied warranties of merchantability and fitness and the express warranties stated herein are in lieu of all obligations or liabilities on the part of General Monitors for damages including, but not limited to, consequential damages arising out of / or in connection with the use or performance of the product.

### 8.2 Specifications

#### 8.2.1 System Specifications

Typical Response Time:	≤ 10 sec for heptane fires when detector is on axis to fire source; ≤ 30 sec when detector is at angles of ±45°
Field of View <sup>9</sup> :	90° @ 210 ft (64 m), 100° @ 100 ft (31 m)
Sensitivity:	60 ft (18 m), 120 ft (37 m), and 210 ft (64 m) for low, medium, and high sensitivities, respectively. Maximum distance for a 1 square foot (0.093 m <sup>2</sup> ) n-heptane fire to be reliably detected. For settings see 3.7 Switch Selectable Options.

---

**NOTE:** Response Times and Field of View data were obtained from tests with a 1 square foot heptane fire. These are typical values and different results may occur depending on the variation of each fire.

---

<sup>9</sup> *Maximum specified FOV* is the angle at which FL4000H can detect the flame at 50% of the maximum specified range.

**Mechanical Specifications**

Enclosure material: 316 Stainless Steel  
 Color: Red  
 Finish: Red Wrinkle Powder Coat

**8.2.2 Dimensions**

Height: 4.3" (109 mm)  
 Diameter: 5.44" (138mm) Base - 3.50" (89 mm) Optical Housing  
 Weight: 7.9 lb. (3.6 kg)

**8.2.3 Electrical Specifications**

Nominal supply voltage: 24 VDC  
 Range: 20 to 36 VDC  
 Maximum supply current: 150 mA  
 Maximum output signal load: 600 Ω @ 24 VDC

	<u>Dual Modbus</u>	<u>HART</u>
Output signal range:	0 to 20 mA	3.5 mA
FAULT signal:	0 to 0.2 mA	3.5 mA
COPM fault signal:	2.0 ± 0.2 mA	3.5 mA
Ready signal:	4.3 ± 0.2 mA	
WARN signal:	16.0 ± 0.2 mA	
ALARM signal:	20.0 ± 0.2 mA	
Relay Contact Ratings:	8 A @ 250 VAC, 8 A @ 30 VDC, Resistive MAX	
RS-485 Output:	Modbus 128 units in series MAX (247 units with repeaters)	
Baud Rate:	2400, 4800, 9600, 19200, and 38400 Baud (See Terminal Connections 3-4 for Alarm Output Connections)	
RFI/EMI Protection:	Complies with EN6100-6-4: 2001 and EN50130-4: 1995+A1: 1998	
Status Indicator:	Two LED's indicate status, fault conditions	

**8.2.4 Environmental Specifications**

Operating temperature range: -40°F to 176°F (-40°C to 80°C)  
 Storage temperature range: -40°F to 176°F (-40°C to 80°C)  
 Humidity range: 0 to 95% RH, non-condensing

**8.2.5 Maximum Cable Parameters**

**0-20 mA Output Signal**

9,000 ft (2,750 m), maximum 50 Ω loop, with maximum 250 Ω input impedance of readout unit.

**Remote Power Supply**

3,000 ft (930 m), maximum 20 Ω loop and 24 VDC minimum (Section 3.6 ).

## 8.3 Regulatory Agency Approvals

### 8.3.1 Regulatory Agencies

The FL4000H is certified by the following regulatory agencies:

Agency	Standard Configuration <sup>10</sup>	HART
ATEX – Hazardous Locations	X	X
Canadian Standards Association (CSA)	X	X
FM Approvals	X	X
HART Communication Foundation (HCF)		X
ULC	X	X

### 8.3.2 Classification Area and Protection Methods

The FL4000H is certified as follows:

- Protection Method: Explosionproof and Flameproof
- Temperature Class: T5 per ATEX
- Area Classifications: Class I, Division 1, Groups B, C, and D  
Class II, Division 1, Groups E, F, and G  
Class III  
Class I, Zone 1, Group IIC per ATEX
- Conforms With: Electromagnetic Compatibility Directive (89/336/EEC)
- Environmental Protection: Type 6P Enclosure, IP67

<sup>10</sup> Dual Modbus with or without relays

## 8.4 Response to False Stimuli

The FL4000H detector is immune to a variety of false alarm sources. Below are representative samples of detector response in the presence of false stimuli.

**Table 38: False Alarm Immunity at High Sensitivity**

<b>False Alarm Source</b>	<b>Distance ft (m)</b>	<b>Modulated Response</b>	<b>Distance ft (m)</b>	<b>Unmodulated Response</b>
Heater (1.5 kW)	6 (1.8)	No alarm	1 (0.3)	No alarm
100 W incandescent lamp	1 (0.3)	No alarm	1 (0.3)	No alarm
Fluorescent lamp (2 40-W bulbs)	< 1 (0.3)	No alarm	< 1 (0.3)	No alarm
500 W halogen lamp	2 (0.6)	No alarm	< 1 (0.3)	No alarm
Sunlight, reflected	6 (1.8)	No alarm	6 (1.8)	No alarm
Sunlight, direct	–	No alarm	–	No alarm
Hot plate (200°C)	3 (0.9)	No alarm	1 (0.3)	No alarm
Arc welding (#6012, 1/8 in, 180 – 200 A, DC)	5 (1.5)	No alarm	11 (3.4)	No alarm
Arc welding (#6012, 1/8 in, 190 A, AC)	5 (1.5)	No alarm	9 (2.7)	No alarm
Arc welding (#7014, 1/8 in, 180 – 200 A, DC)	15 (4.6)	No alarm	12 (3.7)	No alarm
Arc welding (#7014, 1/8 in, 190 A, AC)	15 (4.6)	No alarm	15 (4.6)	No alarm
Arc welding (#7018, 1/8 in, 180 – 200 A, DC)	15 (4.6)	No alarm	13 (4.0)	No alarm
Arc welding (#7018, 1/8 in, 190 A, AC)	12 (3.7)	No alarm	10 (3.1)	No alarm

Table 39 shows the response characteristics of the FL4000H in the presence of false alarm sources. The detector is set at a high sensitivity in this illustration.

**Table 39: Flame Response in the Presence of False Alarm Sources (High Sensitivity)**

<b>False Alarm Source</b>	<b>Max. Distance ft (m)</b>	<b>Fire Source</b>	<b>Min. Distance ft (m)</b>
Sunlight, reflected, unmodulated	6 (1.8)	1 x 1 ft <sup>2</sup> heptane	35 (10.7)
Sunlight, reflected, modulated	30 (9.1)	1 x 1 ft <sup>2</sup> heptane	30 (9.1)
Heater, unmodulated	1 (0.3)	1 x 1 ft <sup>2</sup> heptane	35 (10.7)
Heater, modulated	12 (3.7)	1 x 1 ft <sup>2</sup> heptane	35 (10.7)
Incandescent lamp, unmodulated	2.5 (0.8)	1 x 1 ft <sup>2</sup> heptane	35 (10.7)
Incandescent lamp, modulated	2.5 (0.8)	1 x 1 ft <sup>2</sup> heptane	35 (10.7)
Fluorescent lamp, unmodulated	2.5 (0.8)	1 x 1 ft <sup>2</sup> heptane	35 (10.7)
Fluorescent lamp, modulated	2.5 (0.8)	1 x 1 ft <sup>2</sup> heptane	80 (24.4)
Halogen lamp, unmodulated	2 (0.6)	1 x 1 ft <sup>2</sup> heptane	70 (21.3)
Halogen lamp, modulated	4 (1.2)	1 x 1 ft <sup>2</sup> heptane	35 (10.7)
Arc welding (#7014, 3/16 in, 190 A), unmodulated	12 (3.7)	1 x 1 ft <sup>2</sup> heptane	80 (24.4)
Arc welding (#7014, 3/16 in, 190 A), modulated	15 (4.6)	1 x 1 ft <sup>2</sup> heptane	80 (24.4)

In general, the operator should try to avoid exposing the detector to false alarm sources. Many false stimuli such as welding or heaters emit high amounts of IR radiation, which tend to degrade the performance of the instrument.

## **8.5 Spare Parts and Accessories**

### **8.5.1 Spare Parts**

When ordering Spare Parts and/or Accessories, please contact the nearest General Monitors Representative or General Monitors directly and give the following information:

- Part Number
- Description
- Quantity

**Table 40: List of Spare Parts**

#	Item Description	Part #
1	Window Cleaning Solution	10272-1
2	Bracket Assembly	71370-1
3	Instruction Manual	MANFL4000H
4	Test Lamp	71655-1

### 8.5.2 Test Lamp

Due to the advanced discrimination of the FL4000H, the TL105 Test Lamp was developed. The Test Lamp is a battery operated, rechargeable, test source specifically designed to test General Monitors' IR Flame Detection Systems. It consists of a high-energy broadband radiation source that emits sufficient energy in the infrared spectra to activate the IR detector. To simulate a fire, the TL105 Test Lamp automatically flashes a signal that the FL4000H recognizes. The lamp must be set to rotary switch position "4" to be recognized by the FL4000H. See Appendix A for details.

#### Operating Instructions

The FL4000H has the ability to be put into a special test mode activated state by momentarily grounding the test mode pin on the unit or by issuing a Modbus write command to register 0x5A. The unit will respond by going into this test mode activated state and by blinking a unique flashing pattern with the green LED on for 0.9 seconds and off for 0.1 seconds. The analog current output will respond by outputting 1.5 mA (3.5 mA with HART). While the FL4000H is activated in test mode via the Test Lamp, the FL4000H will detect the TL105 Test Lamp as a flame source. The analog output and relays will respond as if a flame were present. The analog output will rise from 1.5 mA (3.5 mA with HART) to 16 mA (warning condition) and then to 20 mA (alarm). Relays will trip. In addition, an alternating red/green LED blink pattern is displayed. By momentarily grounding the test mode pin a second time, or by re-issuing a Modbus write command to register 0x5A, or after a 3-minute time out, the unit will return to normal operation in the Ready state.

**NOTE:** The TL105 Test Lamp triggers the FL4000H into test mode, causing an alarm condition.

It is important to begin a series of flame detector checks with a fully charged Test Lamp. Stand between 10 and 35 feet from the FL4000H that is to be tested and aim the Test Lamp directly into the detector window. Press the ON button and be sure the high intensity pulsing beam strikes the detector face squarely. Hold the Test Lamp as steady as possible.

To conserve charge, do not operate the Test Lamp longer than is necessary to test each channel.

When the battery level drops below the level required to maintain the proper intensity of the lamp, an internal low voltage circuit will shut the lamp off until the battery has been recharged. Please refer to the TL105 Test Lamp manual for complete operating instructions.

### Recharging Instructions

---

**NOTE:** Charging must be carried out in a non-hazardous area. The charging receptacle is located inside the housing adjacent to the ON button. To gain access, it is necessary to unscrew the knurled plug from the body of the unit. The plug is secured to the ON button by a safety strap to keep it from being lost.

---

Insert the charging plug into the receptacle. Complete recharging takes 3.5 hours, minimum.

---

**NOTE:** Replace the plug after charging is complete.

---

It is recommended that the Test Lamp be kept on charge when not in use to prevent excessive battery discharge. The batteries may be charged an average of 500 times before the battery pack must be replaced.

### 8.5.3 Mounting Bracket

A mounting bracket is available to mount the FL4000H to a wall, pole, etc. The mounting bracket design allows for optical alignment adjustments when utilizing to a fixed installation. Please refer to Figure 16: Detector Mounting and Installation.

## 9.0 Appendix A

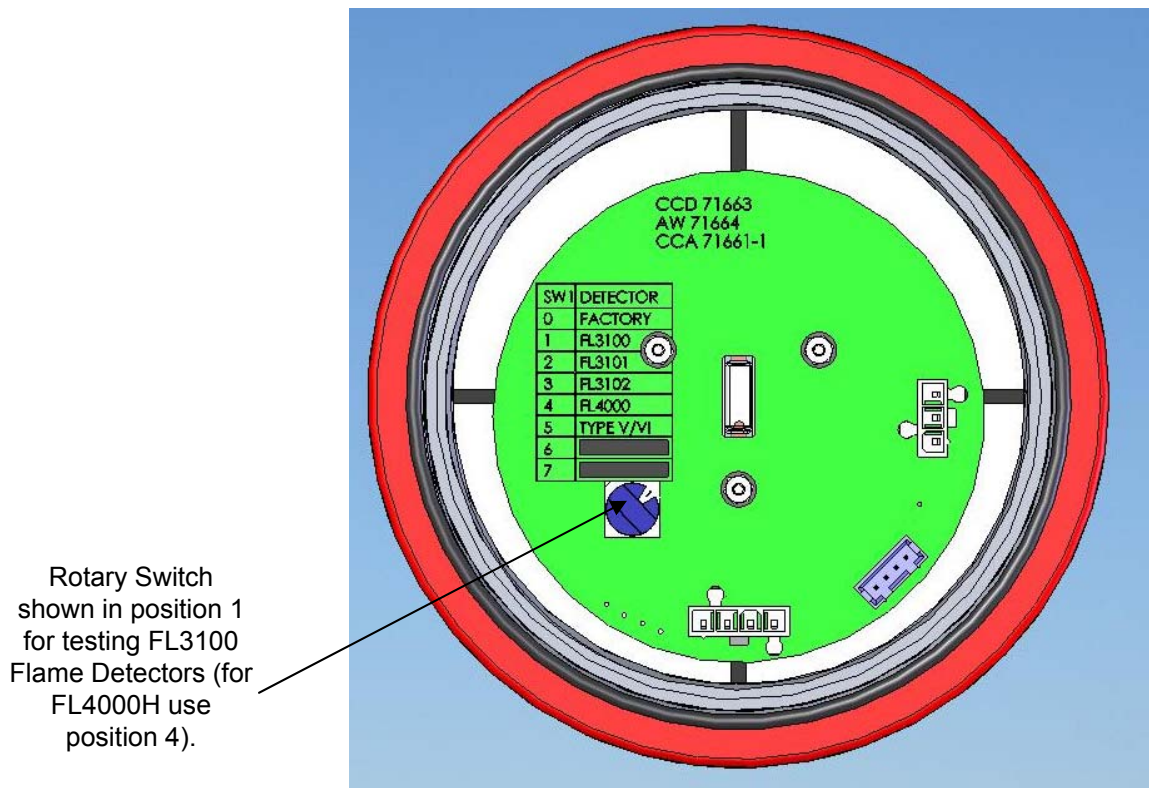











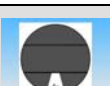
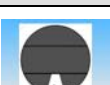

Figure 27: Functional Board Located Under TL105 Lamp Assembly

**Table 41: Detector Test Mode Initiation or/Detector Alarm Trigger with Test Lamp**

Flame Detector to Test	Rotary Switch Setting	Maximum Distance to Detector (ft)	Results
UV & UV/IR Type V & VI		15	UV & UV/IR Type V & VI triggers into alarm mode
FL3000		15	FL3000 triggers into alarm mode
FL3001		35	FL3001 triggers into alarm mode
FL3002		10	FL3002 triggers into alarm mode
FL3100		20	FL3100 triggers into alarm mode
FL3101		35	FL3101 triggers into alarm mode
FL3102		10	FL3102 triggers into alarm mode
FL3110		20	FL3110 triggers into alarm mode
FL3111		35	FL3111 triggers into alarm mode
FL3112		8	FL3112 triggers into alarm mode
FL4000H		35 (High Sensitivity)	FL4000H enters test mode
FL4000H		18 (Medium Sensitivity)	FL4000H enters test mode
FL4000H		8 (Low Sensitivity)	FL4000H enters test mode



**ADDENDUM**  
**Product Disposal Considerations**

This product may contain hazardous and/or toxic substances.

EU Member states shall dispose according to WEEE regulations. For further General Monitors' product WEEE disposal information please visit:

[www.generalmonitors.com/customer\\_support/faq\\_general.html](http://www.generalmonitors.com/customer_support/faq_general.html)

All other countries or states: please dispose of in accordance with existing federal, state and local environmental control regulations.

# **FL4000H HART**

**Multi-Spectral Infrared Flame Detector**

HART Communication with the FL4000H Multi-spectral Infrared  
Detector

# Table of Contents

<b>1.0 INTRODUCTION .....</b>	<b>1</b>
1.1 Scope .....	1
1.2 Purpose .....	1
1.3 Who should use this document? .....	1
1.4 References .....	1
<b>2.0 DEVICE IDENTIFICATION .....</b>	<b>1</b>
<b>3.0 PRODUCT OVERVIEW .....</b>	<b>2</b>
3.1 Getting Started .....	2
<b>4.0 PRODUCT INTERFACES .....</b>	<b>3</b>
4.1 Process Interface .....	3
4.2 Host Interface .....	3
4.3 Local Interfaces, Jumpers, and Switches .....	3
<b>5.0 DEVICE VARIABLES .....</b>	<b>3</b>
<b>6.0 DYNAMIC VARIABLES .....</b>	<b>3</b>
6.1 Primary Variable = FL4000H HART Operating Mode .....	3
6.2 Secondary, Tertiary, and Quaternary Variables: Not Applicable .....	3
<b>7.0 STATUS INFORMATION .....</b>	<b>4</b>
<b>8.0 UNIVERSAL COMMANDS .....</b>	<b>5</b>
<b>9.0 COMMON PRACTICE COMMANDS .....</b>	<b>6</b>
9.1 Supported Commands .....	6
9.2 Burst Mode .....	6
9.3 Catch Device Variable .....	6
<b>10.0 DEVICE SPECIFIC COMMANDS .....</b>	<b>7</b>
10.1 Command #128: Read DIP Switch Override Register (MODBUS Reg 0x07) .....	7
10.2 Command #129: Write DIP Switch Override Register (MODBUS Reg 0x07) .....	7
10.3 Command #130: Read DIP Switch Settings Register (MODBUS Reg 0x46) .....	8
10.4 Command #131: Read Unit Options Register (MODBUS Reg 0x08) .....	8
10.5 Command #132: Write Unit Options Register (MODBUS Reg 0x08) .....	9
10.6 Command #133: Read COPM Fault Status Registers .....	9
10.7 Command #134: Clear COPM Faults (MODBUS Reg 0x13) .....	10
10.8 Command #135: Remote Alarm Reset (MODBUS Reg 0x11) .....	10
10.9 Command #136: Remote Alarm Test (MODBUS Reg 0x12) .....	11
10.10 Command #137: Read Instrument Temperature (MODBUS Reg 0x14) .....	11



10.11 Command #138: Set/Reset Test Lamp Mode (MODBUS Reg 0x5A) ..... 12

10.12 Command #139: Read Test Lamp Mode (MODBUS Reg 0x5A) ..... 12

10.13 Command #140: Read Alarm Delay (MODBUS Reg 0x5B) ..... 13

10.14 Command #141: Set Alarm Delay (MODBUS Reg 0x5B) ..... 13

10.15 Command #142: Read Time Stamp (MODBUS Reg 0x6A, 0x6B, 0x6C) ..... 14

10.16 Command #143: Read Event Logging Counters (MODBUS Reg 0xA8, 0xB0, 0xB8, 0xC0) .. 14

10.17 Command #144: Clear Event Logging Counters (MODBUS Reg 0xC1)..... 15

10.18 Command #145: Read Warning Event Log ..... 15

10.19 Command #146: Read Alarm Event Log ..... 16

10.20 Command #147: Read Fault Event Log..... 16

10.21 Command #148: Read Maintenance Event Log ..... 17

10.22 Command #149: Set Clock ..... 18

10.23 Command #150: Read Clock..... 18

10.24 Command #151: Set Run Time Meter ..... 19

10.25 Command #152: Read Run Time Meter ..... 19

10.26 Command #153: Read Power Cycle Flag ..... 20

10.27 Command #154: Set Event Log Index ..... 20

10.28 Command #155: Read Event Log Index..... 22

10.29 Command #156: Read Remote Alarm Test Mode..... 22

10.30 Command #157: Set Warning Relay Latched Status ..... 23

10.31 Command #158: Read Warning Relay Latched Status ..... 23

10.32 Command #159: Set Warning Relay De-Energized/Energized Status..... 23

10.33 Command #160: Read Warning Relay De-Energized/Energized Status ..... 24

10.34 Command #161: Set Alarm Relay Latched Status ..... 24

10.35 Command #162: Read Alarm Relay Latched Status ..... 25

10.36 Command #163: Set Alarm Relay De-Energized/Energized Status..... 25

10.37 Command #164: Read Alarm Relay De-Energized/Energized Status ..... 26

10.38 Command #165: Set Sensitivity Level ..... 26

10.39 Command #166: Read Sensitivity Level ..... 27

10.40 Command #167: Read PV Mode ..... 27

10.41 Command #168: Read Error Status..... 28

10.42 Command #169: Read Line Voltage..... 28

10.43 Command #170: Read Analog Voltage ..... 29

**11.0 TABLES ..... 30**

11.1 FL4000H HART – Device Specific Commands Summary..... 30

11.2 FL4000H HART – Operating Mode - PV Values ..... 31

11.3 COPM Fault Register ..... 32

11.4 Fault Event Log – Cause Description ..... 32

11.5 Maintenance Event Log – Cause Description..... 32

11.6 DIP Switch Settings Register ..... 33

11.7 Unit Options Settings Register ..... 34

**12.0 PERFORMANCE ..... 35**

12.1 Sampling Rates ..... 35

12.2 Power-up..... 35

12.3 Device Reset..... 35

12.4 Self-Test..... 35

12.5 Command Response Delay ..... 35

12.6 Busy and Delayed-Response ..... 35



12.7	Long Messages.....	35
12.8	Non-Volatile Memory.....	35
12.9	Operating Modes.....	36
12.10	Write Protection.....	36
<b>13.0</b>	<b>ANNEX A. CAPABILITY CHECKLIST .....</b>	<b>36</b>
<b>14.0</b>	<b>ANNEX B. DEFAULT CONFIGURATION .....</b>	<b>37</b>
<b>15.0</b>	<b>ANNEX C. DEVICE DESCRIPTOR LANGUAGE MENU .....</b>	<b>38</b>

## Table of Tables

Table 1: Field Device Identification Data.....	1
Table 2: Error Status Information .....	4
Table 3: FL4000H HART – Common Practice Commands.....	6
Table 4: FL4000H HART – Device Specific Commands.....	30
Table 5: FL4000H HART - Operating Mode - PV Values.....	31
Table 6: COPM Fault Register Values .....	32
Table 7: Fault Event Log – Cause Description.....	32
Table 8: Maintenance Event Log – Cause Description .....	33
Table 9: DIP Switch Settings Register Description .....	33
Table 10: Unit Options Settings.....	34
Table 11: Command Response Times.....	35
Table 12: Capability Checklist .....	36
Table 13: Default Configuration.....	37

# 1.0 Introduction

## 1.1 Scope

The FL4000H HART Multi-Spectral Infrared (MSIR) flame detector complies with HART Protocol Revision 6.0. This document specifies all of the device specific features and documents HART Protocol implementation details. The functionality of this Field Device is described sufficiently to allow its proper application in a process and its complete support in HART capable Host Applications.

There shall be no changes in any of the performance criteria of the FL4000H due to the addition of the HART protocol communications channel.

## 1.2 Purpose

This specification is designed to complement the FL4000H Instruction Manual by providing a complete description of this field device from a HART Communications perspective.

## 1.3 Who should use this document?

This specification is designed to be a technical reference for HART capable host application developers, system integrators, and knowledgeable end users.

## 1.4 References

DOCUMENT NAME	DOCUMENT RELATIONSHIP
HART Communications Protocol Specifications	This is used to insure compliance with the HART Communication Protocol.
FL4000H Instruction Manual	This is the General Monitors, Inc. FL4000H Product Instruction Manual.

# 2.0 Device Identification

The following Table 42 is the Field Device Identification Data for the instrument.

**Table 42: Field Device Identification Data**

Manufacturer's Name	General Monitors, Inc.	Model Number	FL4000 HART
HART ID Code	223 (DF Hex)	Device Type Code:	128 (80 Hex)
HART Protocol Revision	6.0	Device Revision:	1
Number of Device Variables	0		
Physical Layers	1		

<b>Manufacturer's Name</b>	<b>General Monitors, Inc.</b>	<b>Model Number</b>	<b>FL4000 HART</b>
<b>Supported</b>			
<b>Physical Device Category</b>	<b>FSK</b>		

### 3.0 Product Overview

The FL4000H HART is a Multi-Spectral Infrared (MSIR) Flame Detector from General Monitors. The FL4000H HART employs state-of-the-art infrared detectors and a sophisticated Artificial Neural Network (ANN) to produce a system that is highly immune to false alarms such as, arc-welding, hot objects, and other sources of radiation.

#### 9.1 Getting Started

In order to enable HART communication with the FL4000H HART detector, users may employ several means including HART handheld communicators or PC-based systems. Using a PC-based software application and a HART interface modem, for example, allow operators to access information from the FL4000H HART. A typical setup is illustrated in Figure 1.

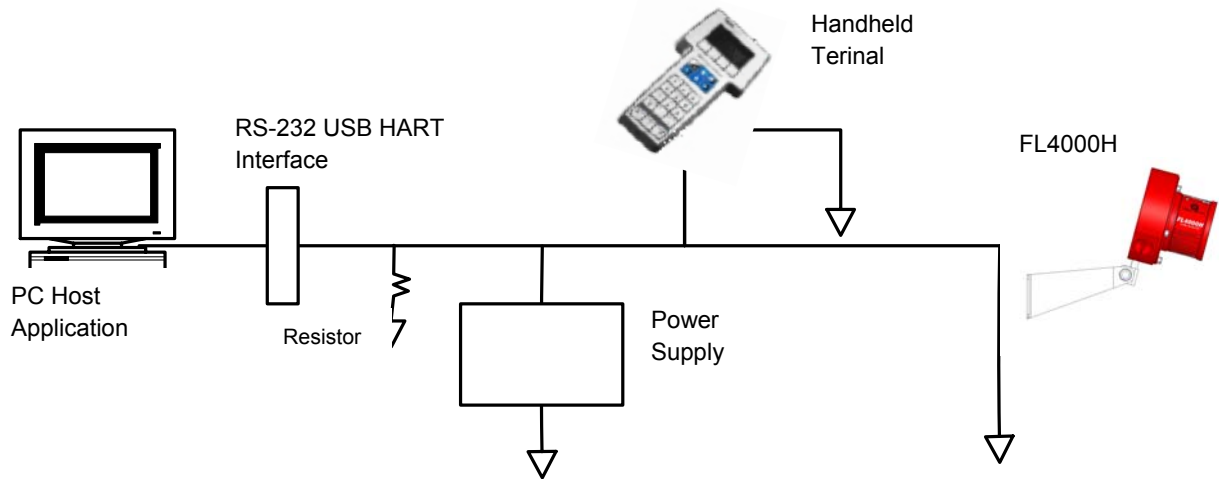

**Figure 1 Connecting a PC to a HART device**

Once the detector is installed (see FL4000H Instruction Manual) and connected to a PC, host application, or handheld terminal, the master will commonly begin communication to the FL4000H HART by using the HART Command #0. The field device will then respond only if its tag matches. The data in the reply to Command #11 is identical to that of Command #0, so the master can then construct the Unique Identifier for use with further commands.

---

**NOTE:** Handheld device allows for the retrieval of diagnostic information and input of device settings as needed and should not be used as a permanent part of a safety system.

---

## 4.0 Product Interfaces

### 4.1 Process Interface

This section describes all interfaces between the devices and the measured process.

#### 4.1.1 Sensor Input Channels

The unit's pyroelectric sensors continually collect data at predetermined wavelengths. These are interpreted by an advanced Artificial Neural Network algorithm to detect flame within the field of view and to reject signals from false flame sources. The results are output to the user via a 4 – 20mA current loop, 3 relays, a HART digital interface, and a MODBUS digital interface

### 4.2 Host Interface

The HART interface uses the 4 – 20mA current loop. Refer to the Installation Manual for connection details.

#### 4.2.1 Analog Output: FL4000H Mode

The FL4000H Mode is output to the user as the primary variable of the HART protocol. Table 46 shows the interpretation of this variable

## 4.3 Local Interfaces, Jumpers, and Switches

### 4.3.1 Local Controls And Displays

Refer to the Installation Manual for connection details

### 4.3.2 Internal Jumpers And Switches

Refer to the Installation Manual for connection details

## 5.0 Device Variables

There are no device variables exposed to the user.

## 6.0 Dynamic Variables

There is only one Dynamic Variable exposed to the user.

### 6.1 Primary Variable = FL4000H HART Operating Mode

The device mode is the variable, which corresponds to the MODBUS register 0x01.

### 6.2 Secondary, Tertiary, and Quaternary Variables: Not Applicable

There are none defined for the FL4000H HART product.

## 7.0 Status Information

The error status, which is returned via Common Practice Command #48, is shown in Table 43 and corresponds to MODBUS register 0x01. This also shows any COPM Faults. These bits may be set at power up to indicate an instrument failure. They may also be set by a failure detected during continuous background diagnostic testing.

**Table 43: Error Status Information**

Byte	Bit	Description	Class	Device Status Bits Set
0 (MOD-BUS Reg #2 MSB)	0	Not Used	N/A	
	1	Not Used	N/A	
	2	Not Used	N/A	
	3	Not Used	N/A	
	4	Not Used	N/A	
	5	Not Used	N/A	
	6	Not Used	N/A	
	7	Reset Short Error	Error	4,7
1 (MOD-BUS Reg #2 LSB)	0	Not Used	N/A	
	1	Not Used	N/A	
	2	Not Used	N/A	
	3	COPM Fault	Error	4,7
	4	Low Voltage	Error	4,7
	5	Not Used	N/A	
	6	Data Flash Error	Error	4,7
	7	Code Flash Error	Error	4,7
2 (MOD BUS Reg #6)	0	Detector 2.2 um Error	Error	4,7
	1	Detector 4.9 um Error	Error	4,7
	2	Detector 4.3 um Error	Error	4,7
	3	Detector 4.45 um Error	Error	4,7
	4	Not Used	N/A	
	5	Not Used	N/A	
	6	Not Used	N/A	
	7	COPM Fault	Error	4,7
3	0	Not Used	N/A	
	1	Not Used	N/A	
	2	Not Used	N/A	
	3	Not Used	N/A	
	4	Not Used	N/A	
	5	Not Used	N/A	
	6	Not Used	N/A	
	7	Not Used	N/A	
4	0	Not Used	N/A	
	1	Not Used	N/A	
	2	Not Used	N/A	
	3	Not Used	N/A	
	4	Not Used	N/A	
	5	Not Used	N/A	
	6	Not Used	N/A	
	7	Not Used	N/A	

Byte	Bit	Description	Class	Device Status Bits Set
5	0	Not Used	N/A	
	1	Not Used	N/A	
	2	Not Used	N/A	
	3	Not Used	N/A	
	4	Not Used	N/A	
	5	Not Used	N/A	
	6	Not Used	N/A	
	7	Not Used	N/A	
6	0	Maintenance Required	Error	4,7
	1	Not Used	N/A	
	2	Not Used	N/A	
	3	Not Used	N/A	
	4	Not Used	N/A	
	5	Not Used	N/A	
	6	Not Used	N/A	
	7	Not Used	N/A	
7	0	Not Used	N/A	
	1	Not Used	N/A	
	2	Not Used	N/A	
	3	Not Used	N/A	
	4	Not Used	N/A	
	5	Not Used	N/A	
	6	Not Used	N/A	
	7	Not Used	N/A	

These bits may be set at power up to indicate an instrument failure. They may also be set by a failure detected during continuous background diagnostic testing.

## 8.0 Universal Commands

Command 3 returns the current loop variable and the primary variable for a total of 9 bytes returned. Command 9 returns the PV only.

## 9.0 Common Practice Commands

The following common practice commands are implemented.

### 9.2 Supported Commands

The following common-practice commands shown in Table 44 are implemented:

**Table 44: FL4000H HART – Common Practice Commands**

Command Number	Byte Number	Meaning
Command 38	N/A	Reset Configuration Changed Flag.
Command 48	0	Read additional Device Status.
Command 48	1	Returns Device Error Status = MODBUS Register 0x02 Hi Byte
Command 48	2	Returns Device Error Status = MODBUS Register 0x02 Hi Byte
Command 48	3	Returns 0
Command 48	4	Returns 0
Command 48	5	Returns 0
Command 48	6	Returns 0x01 – “Maintenance Required”
Command 48	7	Returns 0

### 9.3 Burst Mode

The FL4000H HART does not support Burst Mode.

### 9.4 Catch Device Variable

This Field Device does not support Catch Device Variable.

## 10.0 Device Specific Commands

The Device Specific commands are used strictly for the unique features of the FL4000H HART and at the discretion of General Monitors. They are described here in section 10.0 and are summarized in Table 45

### 10.1 Command #128: Read DIP Switch Override Register (MODBUS Reg 0x07)

Read the DIP Switch Override Register.

Request Data Bytes

Byte	Format	Description
None	N/A	N/A

Response Data Bytes

Byte	Format	Description
0	Bits	Override Bit – LSB = 1, enabled: Allow Override. LSB = 0, disabled: Disallow Override

Command-Specific Response Codes

Code	Class	Description
0	Success	No Command-Specific Errors
1-127		Undefined

### 10.2 Command #129: Write DIP Switch Override Register (MODBUS Reg 0x07)

Write the DIP Switch Override Register. This command loads the unit options based on the values of either the flash or the actual DIP switch settings.

Request Data Bytes

Byte	Format	Description
0	Bits	Override Bit – LSB = 1, enabled: Allow Override. LSB = 0, disabled: Disallow Override

Response Data Bytes

Byte	Format	Description
0	Bits	Override Bit – LSB = 1, enabled: Allow Override. LSB = 0, disabled: Disallow Override

**Command-Specific Response Codes**

Code	Class	Description
0	Success	No Command-Specific Errors
1- 2		Undefined
3	Error	Passed Parameter Too Large
4 – 127		Undefined
5	Error	Too Few Data Bytes Received

**10.3 Command #130: Read DIP Switch Settings Register (MODBUS Reg 0x46)**

Reads the DIP Switch Settings Register.

**Request Data Bytes**

Byte	Format	Description
None	N/A	N/A

**Response Data Bytes**

Byte	Format	Description
0	Bits	DIP Switch Settings Table 50

**Command-Specific Response Codes**

Code	Class	Description
0	Success	No Command-Specific Errors
1-127		Undefined

**10.4 Command #131: Read Unit Options Register (MODBUS Reg 0x08)**

Reads the Unit Options Register.

**Request Data Bytes**

Byte	Format	Description
None	N/A	N/A

**Response Data Bytes**

Byte	Format	Description
0	Bits	Unit Options – See Table 51

**Command-Specific Response Codes**

Code	Class	Description
0	Success	No Command-Specific Errors
1-127		Undefined

**10.5 Command #132: Write Unit Options Register (MODBUS Reg 0x08)**

Write the Unit Options Register.

Request Data Bytes

Byte	Format	Description
0	Bits	Unit Options – See Table 51

**Response Data Bytes**

Byte	Format	Description
0	Bits	Unit Options – See Table 51

**Command-Specific Response Codes**

Code	Class	Description
0	Success	No Command-Specific Errors
1 - 6		Undefined
7	Error	Write Protect Mode
8 – 127		Undefined

**10.6 Command #133: Read COPM Fault Status Registers**

Reads the COPM Fault Status Registers.

**Request Data Bytes**

Byte	Format	Description
None	N/A	N/A

**Response Data Bytes**

Byte	Format	Description
0	Bits	COPM Fault Register (MODBUS Reg 0x06) – See Table 47
1 - 2	Unsigned-16	Sensor 1 Fault Count
3 - 4	Unsigned-16	Sensor 2 Fault Count

5 - 6	Unsigned-16	Sensor 3 Fault Count
7 - 8	Unsigned-16	Sensor 4 Fault Count

**Command-Specific Response Codes**

Code	Class	Description
0	Success	No Command-Specific Errors
1-127		Undefined

### 10.7 Command #134: Clear COPM Faults (MODBUS Reg 0x13)

Clear the COPM Faults Register.

**Request Data Bytes**

Byte	Format	Description
None	N/A	N/A

**Response Data Bytes**

Byte	Format	Description
None	N/A	N/A

**Command-Specific Response Codes**

Code	Class	Description
0	Success	No Command-Specific Errors
1-127		Undefined

### 10.8 Command #135: Remote Alarm Reset (MODBUS Reg 0x11)

Reset the Remote Alarm. This resets any relays which might be latched.

**Request Data Bytes**

Byte	Format	Description
None	N/A	N/A

**Response Data Bytes**

Byte	Format	Description
None	N/A	N/A

**Command-Specific Response Codes**

Code	Class	Description
0	Success	No Command-Specific Errors

Code	Class	Description
1-127		Undefined

### 10.9 Command #136: Remote Alarm Test (MODBUS Reg 0x12)

Test the Remote Alarm.

#### Request Data Bytes

Byte	Format	Description
0	Bits	Test Remote Alarm: 0 = Turn off, 1 = Turn on Alarm

#### Response Data Bytes

Byte	Format	Description
0	Bits	Test Remote Alarm: 0 = Alarm Off, 1 = Alarm On

#### Command-Specific Response Codes

Code	Class	Description
0	Success	No Command-Specific Errors
1-127		Undefined

### 10.10 Command #137: Read Instrument Temperature (MODBUS Reg 0x14)

Read the temperature of the instrument.

#### Request Data Bytes

Byte	Format	Description
None	N/A	N/A

#### Response Data Bytes

Byte	Format	Description
0 - 1	Signed-16	Temperature Value
2	Enum	Degrees Celsius

#### Command-Specific Response Codes

Code	Class	Description
0	Success	No Command-Specific Errors
1-127		Undefined

### 10.11 Command #138: Set/Reset Test Lamp Mode (MODBUS Reg 0x5A)

Set/Reset the Test Lamp Mode.

#### Request Data Bytes

Byte	Format	Description
0	Bits	Set/Reset Test Mode: 1 = Test Mode, 0 = Non-Test Mode

#### Response Data Bytes

Byte	Format	Description
0	Bits	Test Mode: 1 = Test Mode, 0 = Non-Test Mode

#### Command-Specific Response Codes

Code	Class	Description
0	Success	No Command-Specific Errors
1-127		Undefined

### 10.12 Command #139: Read Test Lamp Mode (MODBUS Reg 0x5A)

Read the Test Lamp Mode.

#### Request Data Bytes

Byte	Format	Description
None	N/A	N/A

#### Response Data Bytes

Byte	Format	Description
0	Bits	Test Mode: 1 = Test Mode, 0 = Non-Test Mode

#### Command-Specific Response Codes

Code	Class	Description
0	Success	No Command-Specific Errors
1-127		Undefined

### 10.13 Command #140: Read Alarm Delay (MODBUS Reg 0x5B)

Read the Alarm Delay.

#### Request Data Bytes

Byte	Format	Description
None	N/A	N/A

#### Response Data Bytes

Byte	Format	Description
0	Unsigned-8	Alarm Delay

#### Command-Specific Response Codes

Code	Class	Description
0	Success	No Command-Specific Errors
1 – 127		Undefined

### 10.14 Command #141: Set Alarm Delay (MODBUS Reg 0x5B)

Set the Alarm Delay. If the DIP override flag is set, then the command will return an ACCESS RESTRICTED code.

#### Request Data Bytes

Byte	Format	Description
0	Unsigned-8	Alarm Delay

#### Response Data Bytes

Byte	Format	Description
0	Unsigned-8	Alarm Delay

#### Command-Specific Response Codes

Code	Class	Description
0	Success	No Command-Specific Errors
1 – 2		Undefined
3	Error	Passed Parameter Too Large
4		Undefined
5	Error	Too Few Data Bytes Received

Code	Class	Description
6 - 15		Undefined
16	Error	Access Restricted
17 - 127		Undefined

### 10.15 Command #142: Read Time Stamp (MODBUS Reg 0x6A, 0x6B, 0x6C)

Read the last time that the test lamp check was successfully performed.

#### Request Data Bytes

Byte	Format	Description
None	N/A	N/A

#### Response Data Bytes

Byte	Format	Description
0 - 2	Date	Last Successful Test Lamp Check
3	Unsigned-8	Last Successful Test Lamp Check – Hour
4	Unsigned-8	Last Successful Test Lamp Check - Minute

#### Command-Specific Response Codes

Code	Class	Description
0	Success	No Command-Specific Errors
1-127		Undefined

### 10.16 Command #143: Read Event Logging Counters (MODBUS Reg 0xA8, 0xB0, 0xB8, 0xC0)

This command reads the four Event Logging Counters to give the number of events which have been stored in each of the event logs. The four event logs record the most recent 10 events which have been recorded by the instrument. These are the most recent: warning time, alarm time, fault time, and test lamp checkout time. The event logs are stored in most recent order and going back to the least recent event. The most recent event is event number 0 and the least recent is event number 9. If fewer than 10 events have been recorded, then the least recent event times will indicate a time stamp of January 1, 2000.

#### Request Data Bytes

Byte	Format	Description
None	N/A	N/A

#### Response Data Bytes

Byte	Format	Description
------	--------	-------------

0 - 1	Unsigned-16	Warning Event Counter
2 - 3	Unsigned-16	Alarm Event Counter
4 - 5	Unsigned-16	Fault Event Counter
6 - 7	Unsigned-16	Maintenance Event Counter

**Command-Specific Response Codes**

Code	Class	Description
0	Success	No Command-Specific Errors
1-127		Undefined

**10.17 Command #144: Clear Event Logging Counters (MODBUS Reg 0xC1)**

This resets the event logging counters to zero – effectively clearing out the event logs of all of the previous information.

**Request Data Bytes**

Byte	Format	Description
None	N/A	N/A

**Response Data Bytes**

Byte	Format	Description
None	N/A	N/A

**Command-Specific Response Codes**

Code	Class	Description
0	Success	No Command-Specific Errors
1-127		Undefined

**10.18 Command #145: Read Warning Event Log**

Read Warning Event Log as specified by the event log number. Event 0 is the most recent event. Event 1 is the one just before that and so forth.

**Request Data Bytes**

Byte	Format	Description
None	N/A	N/A

**Response Data Bytes**

Byte	Format	Description
0 - 3	Unsigned-32	Event Running Time (in Seconds)

4 - 6	Date	Event Date – Day, Month, Year – 1900
7	Unsigned-8	Event Hour
8	Unsigned-8	Event Minute
9	Unsigned-8	Event Second

**Command-Specific Response Codes**

Code	Class	Description
0	Success	No Command-Specific Errors
1-127		Undefined

**10.19 Command #146: Read Alarm Event Log**

Read Alarm Event Log as specified by the event log number. Event 0 is the most recent event. Event 1 is the one just before that and so forth.

**Request Data Bytes**

Byte	Format	Description
None	N/A	N/A

**Response Data Bytes**

Byte	Format	Description
0 - 3	Unsigned-32	Event Running Time (in Seconds)
4 - 6	Date	Event Date – Day, Month, Year – 1900
7	Unsigned-8	Event Hour
8	Unsigned-8	Event Minute
9	Unsigned-8	Event Second

**Command-Specific Response Codes**

Code	Class	Description
0	Success	No Command-Specific Errors
1-127		Undefined

**10.20 Command #147: Read Fault Event Log**

Read Fault Event Log as specified by the event log number. Event 0 is the most recent event. Event 1 is the one just before that and so forth.

**Request Data Bytes**

Byte	Format	Description
None	N/A	N/A

**Response Data Bytes**

Byte	Format	Description
0 - 3	Unsigned-32	Event Running Time (in Seconds)
4 - 6	Date	Event Date – Day, Month, Year – 1900
7	Unsigned-8	Event Hour
8	Unsigned-8	Event Minute
9	Unsigned-8	Event Second
10	Unsigned-8	Event Cause – See Table 7

**Command-Specific Response Codes**

Code	Class	Description
0	Success	No Command-Specific Errors
1-127		Undefined

## 10.21 Command #148: Read Maintenance Event Log

Read Maintenance Event Log as specified by the event log number. Event 0 is the most recent event. Event 1 is the one just before that and so forth.

**Request Data Bytes**

Byte	Format	Description
None	N/A	N/A

**Response Data Bytes**

Byte	Format	Description
0 - 3	Unsigned-32	Event Running Time (in Seconds)
4 - 6	Date	Event Date – Day, Month, Year – 1900
7	Unsigned-8	Event Hour
8	Unsigned-8	Event Minute
9	Unsigned-8	Event Second
10	Unsigned-16	Event Cause – See Table 49

**Command-Specific Response Codes**

Code	Class	Description
0	Success	No Command-Specific Errors
1-127		Undefined

## 10.22 Command #149: Set Clock

Set the internal real-time clock.

### Request Data Bytes

Byte	Format	Description
0 – 2	Date	Date in Day, Month, Year-1900
3	Unsigned-8	Hours
4	Unsigned-8	Minutes
5	Unsigned-8	Seconds

### Response Data Bytes

Byte	Format	Description
0 – 2	Date	Date in Day, Month, Year-1900
3	Unsigned-8	Hours
4	Unsigned-8	Minutes
5	Unsigned-8	Seconds

### Command-Specific Response Codes

Code	Class	Description
0	Success	No Command-Specific Errors
1-127		Undefined

## 10.23 Command #150: Read Clock

Read the internal real-time clock setting.

### Request Data Bytes

Byte	Format	Description
0	N/A	N/A

### Response Data Bytes

Byte	Format	Description
0 – 2	Date	Date in Day, Month, Year-1900
3	Unsigned-8	Hours

4	Unsigned-8	Minutes
5	Unsigned-8	Seconds

**Command-Specific Response Codes**

Code	Class	Description
0	Success	No Command-Specific Errors
1-127		Undefined

### 10.24 Command #151: Set Run Time Meter

Set the internal run time meter.

**Request Data Bytes**

Byte	Format	Description
0 - 3	Unsigned-32	Run Time Meter Value

**Response Data Bytes**

Byte	Format	Description
0 - 3	Unsigned-32	Run Time Meter Value

**Command-Specific Response Codes**

Code	Class	Description
0	Success	No Command-Specific Errors
1-127		Undefined

### 10.25 Command #152: Read Run Time Meter

Read the internal run time meter.

**Request Data Bytes**

Byte	Format	Description
0	N/A	N/A

**Response Data Bytes**

Byte	Format	Description
0 - 3	Unsigned-32	Run Time Meter Value

**Command-Specific Response Codes**

Code	Class	Description
0	Success	No Command-Specific Errors
1-127		Undefined

### 10.26 Command #153: Read Power Cycle Flag

Read the Power cycle flag. This flag is set equal to one whenever the power is cycled to the unit. When the clock is set via either by command number 149 or 151, this flag is reset to zero.

#### Request Data Bytes

Byte	Format	Description
0	N/A	N/A

#### Response Data Bytes

Byte	Format	Description
0	Unsigned-8	Power Cycled Flag Value

#### Command-Specific Response Codes

Code	Class	Description
0	Success	No Command-Specific Errors
1-127		Undefined

### 10.27 Command #154: Set Event Log Index

Set the Event Log Index to a specified value. This index is used by commands 145, 146, 147, & 148 to retrieve the event information stored in the instrument. The events are accumulated automatically by the instrument. The most recent event to have occurred is event #0. The next most recent event to have occurred is event # 1. The least recent event is event # 9.

#### Request Data Bytes

Byte	Format	Description
0	Unsigned-8	Event Index

#### Response Data Bytes

Byte	Format	Description
0	Unsigned-8	Event Index

#### Command-Specific Response Codes

Code	Class	Description
0	Success	No Command-Specific Errors



---

Code	Class	Description
1-127		Undefined

## 10.28 Command #155: Read Event Log Index

Read the Event Log Index to a specified value. This index is used by commands 145, 146, 147, & 148 to retrieve the event information stored in the instrument. The events are accumulated automatically by the instrument. The most recent event to have occurred is event #0. The next most recent event to have occurred is event # 1. The least recent event is event # 9.

### Request Data Bytes

Byte	Format	Description
0	N/A	N/A

### Response Data Bytes

Byte	Format	Description
0	Unsigned-8	Event Index

### Command-Specific Response Codes

Code	Class	Description
0	Success	No Command-Specific Errors
1-127		Undefined

## 10.29 Command #156: Read Remote Alarm Test Mode

Read the Remote Alarm Test Mode. A value of 0 indicates normal mode. A value of 1 indicates that the unit is in alarm test mode.

### Request Data Bytes

Byte	Format	Description
0	N/A	N/A

### Response Data Bytes

Byte	Format	Description
0	Unsigned-8	Remote Alarm Test Mode

### Command-Specific Response Codes

Code	Class	Description
0	Success	No Command-Specific Errors
1-127		Undefined

### 10.30 Command #157: Set Warning Relay Latched Status

This sets the warning relay to either latched or un-latched. If the DIP override flag is set, then the command will return an ACCESS RESTRICTED code.

#### Request Data Bytes

Byte	Format	Description
0	Unsigned-8	Relay setting: 1 = latched, 0 = un-latched

#### Response Data Bytes

Byte	Format	Description
0	Unsigned-8	Relay setting: 1 = latched, 0 = un-latched

#### Command-Specific Response Codes

Code	Class	Description
0	Success	No Command-Specific Errors
1 - 15		Undefined
16	Error	Access Restricted
17 - 127		Undefined

### 10.31 Command #158: Read Warning Relay Latched Status

This reads the latched status of the warning relay.

#### Request Data Bytes

Byte	Format	Description
0	N/A	N/A

#### Response Data Bytes

Byte	Format	Description
0	Unsigned-8	Relay setting: 1 = latched, 0 = un-latched

#### Command-Specific Response Codes

Code	Class	Description
0	Success	No Command-Specific Errors
1-127		Undefined

### 10.32 Command #159: Set Warning Relay De-Energized/Energized Status

This sets the warning relay to either De-Energized or Energized. If the DIP override flag is set, then the command will return an ACCESS RESTRICTED code.

**Request Data Bytes**

Byte	Format	Description
0	N/A	N/A

**Response Data Bytes**

Byte	Format	Description
0	Unsigned-8	Relay setting: 1 = Energized, 0 = De-Energized

**Command-Specific Response Codes**

Code	Class	Description
0	Success	No Command-Specific Errors
1 - 15		Undefined
16	Error	Access Restricted
17 - 127		Undefined

### 10.33 Command #160: Read Warning Relay De-Energized/Energized Status

This reads the Energized/De-Energized status of the warning relay.

**Request Data Bytes**

Byte	Format	Description
0	N/A	N/A

**Response Data Bytes**

Byte	Format	Description
0	Unsigned-8	Warning Relay Status: 1 = Energized, 0 = De-Energized

**Command-Specific Response Codes**

Code	Class	Description
0	Success	No Command-Specific Errors
1-127		Undefined

### 10.34 Command #161: Set Alarm Relay Latched Status

This sets the alarm relay to either latched or un-latched. If the DIP override flag is set, then the command will return an ACCESS RESTRICTED code.

**Request Data Bytes**

Byte	Format	Description
------	--------	-------------

0	Unsigned-8	Alarm Relay Status: 1 = Latched, 0 = Unlatched
---	------------	--

**Response Data Bytes**

Byte	Format	Description
0	Unsigned-8	Alarm Relay Status: 1 = Latched, 0 = Unlatched

**Command-Specific Response Codes**

Code	Class	Description
0	Success	No Command-Specific Errors
1 - 15		Undefined
16	Error	Write Protect Mode
17 - 127		Undefined

### 10.35 Command #162: Read Alarm Relay Latched Status

Read the Remote Alarm Test Mode. A value of 0 indicates normal mode. A value of 1 indicates that the unit is in alarm test mode.

**Request Data Bytes**

Byte	Format	Description
0	N/A	N/A

**Response Data Bytes**

Byte	Format	Description
0	Unsigned-8	Alarm Relay Status: 1 = Latched, 0 = Unlatched

**Command-Specific Response Codes**

Code	Class	Description
0	Success	No Command-Specific Errors
1-127		Undefined

### 10.36 Command #163: Set Alarm Relay De-Energized/Energized Status

This sets the alarm relay status to be either De-Energized or Energized. If the DIP override flag is set, then the command will return an ACCESS RESTRICTED code.

**Request Data Bytes**

Byte	Format	Description
0	Unsigned-8	Alarm Relay Status: 1 = Energized, 0 = De-Energized

**Response Data Bytes**

Byte	Format	Description
------	--------	-------------

0	Unsigned-8	Alarm Relay Status: 1 = Energized, 0 = De-Energized
---	------------	---

**Command-Specific Response Codes**

Code	Class	Description
0	Success	No Command-Specific Errors
1 - 15		Undefined
16	Error	Access Restricted
17 - 127		Undefined

**10.37 Command #164: Read Alarm Relay De-Energized/Energized Status**

This reads the Energized/De-Energized status of the alarm relay.

**Request Data Bytes**

Byte	Format	Description
0	N/A	N/A

**Response Data Bytes**

Byte	Format	Description
0	Unsigned-8	Alarm Relay Status: 1 = Energized, 0 = De-Energized

**Command-Specific Response Codes**

Code	Class	Description
0	Success	No Command-Specific Errors
1-127		Undefined

**10.38 Command #165: Set Sensitivity Level**

This sets the unit sensitivity. It may have the values of high, medium, or low. If the DIP override flag is set, then the command will return an ACCESS RESTRICTED code.

**Request Data Bytes**

Byte	Format	Description
0	Unsigned-8	Unit Sensitivity Level: 0 = High, 1 = Medium, 2 = Low

**Response Data Bytes**

Byte	Format	Description
0	Unsigned-8	Unit Sensitivity Level: 0 = High, 1 = Medium, 2 = Low

**Command-Specific Response Codes**

Code	Class	Description
0	Success	No Command-Specific Errors
1 -15		Undefined
16	Error	Access Restricted
17-127		Undefined

**10.39 Command #166: Read Sensitivity Level**

This reads the unit sensitivity. It may have values of high, medium, or low.

**Request Data Bytes**

Byte	Format	Description
0	N/A	N/A

**Response Data Bytes**

Byte	Format	Description
0	Unsigned-8	Unit Sensitivity Level: 0 = High, 1 = Medium, 2 = Low

**Command-Specific Response Codes**

Code	Class	Description
0	Success	No Command-Specific Errors
1-127		Undefined

**10.40 Command #167: Read PV Mode**

This reads the Primary Variable mode of the unit. It is the same as MODBUS register 0x01.

**Request Data Bytes**

Byte	Format	Description
0	N/A	N/A

**Response Data Bytes**

Byte	Format	Description
0	Unsigned-8	PV = replicate of MODBUS Reg 0x01

**Command-Specific Response Codes**

Code	Class	Description
0	Success	No Command-Specific Errors
1-127		Undefined

**10.41 Command #168: Read Error Status**

Read the Instrument Error Status. This is similar to MODBUS Register 0x02 except that the errors are prioritized as listed in the description.

**Request Data Bytes**

Byte	Format	Description
0	N/A	N/A

**Response Data Bytes**

Byte	Format	Description
0	Unsigned-8	Error Status: 0 = No Error, 1 = Low Voltage, 2 = COPM Fault, 3 = Reset Line Shorted, 4 = FLASH Error.

**Command-Specific Response Codes**

Code	Class	Description
0	Success	No Command-Specific Errors
1-127		Undefined

**10.42 Command #169: Read Line Voltage**

Read the Line Voltage. This is the voltage as seen at the CPU input measured in Volts.

**Request Data Bytes**

Byte	Format	Description
0	N/A	N/A

**Response Data Bytes**

Byte	Format	Description
0 – 3	Float	Line Voltage in Volts
4	Enum	VOLTS

**Command-Specific Response Codes**

Code	Class	Description
0	Success	No Command-Specific Errors
1-127		Undefined

**10.43 Command #170: Read Analog Voltage**

This replicates the functionality of Command #2 for the AMS.

**Request Data Bytes**

Byte	Format	Description
0	N/A	N/A

**Response Data Bytes**

Byte	Format	Description
0 – 3	Float	Analog Output
4 - 7	Float	Analog Output as a percent of full scale

**Command-Specific Response Codes**

Code	Class	Description
0	Success	No Command-Specific Errors
1-127		Undefined

## 11.0 Tables

### 11.1 FL4000H HART – Device Specific Commands Summary

The following Table 45 is a summary of the FL4000H HART Device Specific Commands. The Reg values in the Meaning Column denote the corresponding MODBUS Register.

**Table 45: FL4000H HART – Device Specific Commands**

Command Number	Byte Number	Meaning
Command 128		Read DIP Switch Override Reg 0x07
Command 129		Write DIP Switch Override Reg 0x07
Command 130		Read DIP Switch Settings Register 0x46
Command 131		Read Unit Options Reg 0x08
Command 132		Write Unit Options Register 0x08
Command 133	0	Read COPM Fault Status Reg 0x06
Command 133	1	COPM Counts sensor 1 Reg 0x0D
Command 133	2	COPM Counts sensor 2 Reg 0x0E
Command 133	3	COPM Counts sensor 3 Reg 0x0F
Command 133	4	COPM Counts sensor 4 Reg 0x10
Command 134		Clear COPM Faults Reg 0x13
Command 135		Remote Alarm Reset Reg 0x11
Command 136		Remote Alarm Test Reg 0x012
Command 137		Read Sensor Temperature Reg 0x14
Command 138		Set/Reset Test Lamp Test Mode Reg 0x5A
Command 139		Read Test Lamp Test Mode Reg 0x5A
Command 140		Read Alarm Delay Reg 0x5B
Command 141		Set Alarm Delay Reg 0x5B
Command 142		Test Lamp Time Stamp Reg 0x6A, 0x6B, 0x6C
Command 143		Read Event Logging Counters: Reg 0xA8, 0xB0, 0xB8, 0xC0
Command 144		Clear Event Logging Counters Reg 0xC1
Command 145		Read Warning Event Log Register
Command 146		Read Alarm Event Log Event Register
Command 147		Read Fault Event Log Register

Command Number	Byte Number	Meaning
Command 148		Read Maintenance Event Log Register
Command 149		Set Clock
Command 150		Read Clock
Command 151		Set Run Time Meter
Command 152		Read Run Time Meter
Command 153		Read Power Cycle Flag
Command 154		Set Event Log Index
Command 155		Read Event Log Index
Command 156		Read Remote Alarm Test Register
Command 157		Set Warning Relay Latched Status
Command 158		Read Warning Relay Latched Status
Command 159		Set Warning Relay De-Energized/Energized
Command 160		Read Warning Relay De-Energized/Energized
Command 161		Set Alarm Relay Latched Status
Command 162		Read Alarm Relay Latched Status
Command 163		Set Alarm Relay De-Energized/Energized
Command 164		Read Alarm Relay De-Energized/Energized
Command 165		Set Unit Sensitivity
Command 166		Read Unit Sensitivity
Command 167		Read PV Mode
Command 168		Read Error Status
Command 169		Read Line Voltage
Command 170		Read Analog Voltage

## 11.2 FL4000H HART – Operating Mode - PV Values

The following Table 46 is a summary of the FL4000H HART Operating Modes:

**Table 46: FL4000H HART - Operating Mode - PV Values**

Operating Mode	Primary Variable Value in Decimal
Power-Up Delay	1
Warn Non-Latching Only	2
Warn and Alarm Non-latching	3

<b>Operating Mode</b>	<b>Primary Variable Value in Decimal</b>
Warn Latching Only, Alarm Off	4
Alarm Latching Only	5
Warn & Alarm Latching	6
Ready State	7
Alarm Test	10
COPM Fault Detected	11
Warn Latching, Alarm Non-latching, Alarm On	12
Test Lamp Cycle	13
Test Lamp Cycle – Fire	14

### 11.3 COPM Fault Register

The following Table 47 describes the COPM Faults as reported by Command #133:

**Table 47: COPM Fault Register Values**

<b>Bits</b>	<b>Cause</b>
0	Detector 1 is in fault
1	Detector 2 is in fault
2	Detector 3 is in fault
3	Detector 4 is in fault
7	At least one of the above detectors is in fault.

### 11.4 Fault Event Log – Cause Description

The following Table 48 describes the cause as reported by the read event log commands:

**Table 48: Fault Event Log – Cause Description**

<b>Code</b>	<b>Cause</b>
0	No Fault
1	Low Voltage Fault
2	COPM Fault
3	Reset Short
4	Checksum error

### 11.5 Maintenance Event Log – Cause Description

The following Table 49 describes the cause as reported by the read event log commands:

**Table 49: Maintenance Event Log – Cause Description**

Bits	Cause
0	Test Lamp Successful Calibrate
1 – 15	N/A

## 11.6 DIP Switch Settings Register

The following Table 50 describes the description of the unit options registers:

**Table 50: DIP Switch Settings Register Description**

#	Option	Off/Open = 0	On/Closed = 1
1	High Sensitivity	1 and 2	
2	Medium Sensitivity	2	1
3	Low Sensitivity	1	2
4	0-Second ALARM Time Delay		3 and 4
5	8-Second ALARM Time Delay	3	4
6	10-Second ALARM Time Delay	3 and 4	
7	14-Second ALARM Time Delay	4	3
8	ALARM Non-Latching	5	
9	ALARM Latching		5
10	WARN Non-Latching	6	
11	WARN Latching		6
12	ALARM Normally Energized		7
13	ALARM Normally De-Energized	7	
14	WARN Normally Energized		8
15	WARN Normally De-Energized	8	

## 11.7 Unit Options Settings Register

The following Table 51 describes the description of the unit options registers:

**Table 51: Unit Options Settings**

Off = 0, On = 1, De = De-energized, En = Energized, La = Latched, NL = Non-Latched

	Warn	Alarm	Warn	Alarm	Delay	Delay	Sensitivity	Sensitivity
<b>Bit</b>	<b>8</b>	<b>7</b>	<b>6</b>	<b>5</b>	<b>4</b>	<b>3</b>	<b>2</b>	<b>1</b>
<b>OFF= 0</b>	De	De	NL	NL				
<b>ON =1</b>	En	En	La	La				

### Delay Settings

Time	Bit 4	Bit 3
<b>0 sec</b>	<b>ON</b>	<b>ON</b>
<b>8 sec</b>	<b>ON</b>	<b>OFF</b>
<b>10 sec</b>	<b>OFF</b>	<b>OFF</b>
<b>14 sec</b>	<b>OFF</b>	<b>ON</b>

### Sensitivity Settings

Sensitivity	Bit 2	Bit 1
<b>High</b>	<b>OFF</b>	<b>OFF</b>
<b>Medium</b>	<b>OFF</b>	<b>ON</b>
<b>Low</b>	<b>ON</b>	<b>OFF</b>
<b>Undefined</b>	<b>ON</b>	<b>ON</b>

## 12.0 Performance

### 12.1 Sampling Rates

The FL4000H HART samples each detector at 10 msec intervals.

### 12.2 Power-up

On power up, the FL4000H HART executes a self-test procedure, which requires approximately 15 seconds. During this time, the analog output is set to 3.5mA. After the self-test is satisfactorily completed, the unit sets the PV to a value representing the mode of the instrument.

### 12.3 Device Reset

The FL4000H HART cannot be reset by any command. The unit only resets when power is cycled.

### 12.4 Self-Test

The FL4000H HART goes through a self-test upon power cycle. Should any of the tests fail, the unit immediately reports a fault condition.

### 12.5 Command Response Delay

The FL4000H HART responds as follows:

**Table 52: Command Response Times**

Response Type	Response Time
Minimum	20ms
Typical	50ms
Maximum	100ms

### 12.6 Busy and Delayed-Response

The FL4000H HART does not use delayed-response times.

### 12.7 Long Messages

The largest data field used by the FL4000H HART is in response to Command 21: 34 bytes including the two status bytes.

### 12.8 Non-Volatile Memory

The FL4000H HART uses EEPROM to hold the device's configuration parameters. New data is written to this memory immediately on execution of a write command.

## 12.9 Operating Modes

The FL4000H HART reports flame detection by setting the instrument in a series of different modes.

## 12.10 Write Protection

The FL4000H HART does not support any write protection mode.

# 13.0 Annex A. Capability Checklist

**Table 53: Capability Checklist**

<b>Manufacturer, model, and revision</b>	<b>General Monitors, Inc. FL4000H</b>
Device type	Infrared Flame Detector
HART revision	6.0
Device Description available	Yes
Number and type of sensors	4 Internal
Number and type of actuators	0
Number and type of host side signals	1: 4 – 20mA analog
Number of Device Variables	0
Number of Dynamic Variables	1
Mappable Dynamic Variables?	No
Number of common-practice commands	3
Number of device-specific commands	15
Bits of additional device status	8
Alternative operating modes?	No
Burst mode?	No
Write-protection?	Mfg Only

## 14.0 Annex B. Default Configuration

**Table 54: Default Configuration**

<b>Parameter</b>	<b>Default value</b>
Lower Range Value	N/A
Upper Range Value	N/A
PV Units	FL4000H HART Operating Mode
Sensor type	Pyroelectric Infrared
Number of wires	3
Damping time constant	N/A
Fault-indication jumper	N/A
Write-protect jumper	N/A
Number of response preambles	5



# 15.0 Annex C. Device Descriptor Language Menu

