

# Mini-Split Installation manual

---

## MM\*D\*\*\*S6M-1P

---

- Thank you for purchasing this Lennox Product.
- Before operating this unit, please read this manual carefully and retain it for future reference.

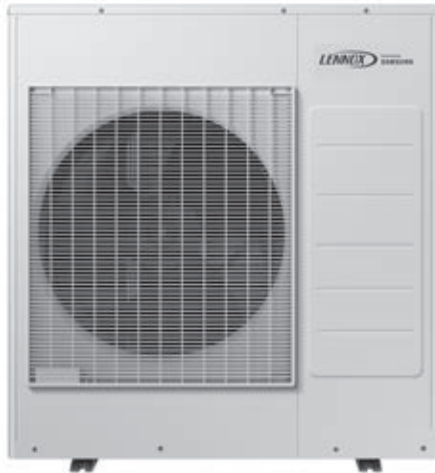

# Contents

---

<b>Safety Information</b>	<b>3</b>
Installing the unit	5
<b>Installation Procedure</b>	<b>11</b>
Step 1 Choosing the installation location	11
Step 2 Checking and preparing accessories and tools	15
Step 3 Fixing the outdoor unit in place	15
Step 4 Connecting the power cables, communication cable, and controllers	16
Step 5 Connecting the refrigerant pipe	23
Step 6 Optional: Cutting and flaring the pipes	26
Step 7 Connecting up and removing air in the circuit	27
Step 8 Performing the gas leak test	28
Step 9 Charging refrigerant (R-32)	29
Step 10 Connecting the drain hose to the outdoor unit	30
Step 11 Checking the grounding	30
Step 12 Setting an indoor unit address and installation option	30
Step 13 Cool and Heat modes operation test	35
Step 14 Optional: Setting to Cool or Heat only mode	35
<b>Extra procedures</b>	<b>36</b>
Pumping down refrigerant	36
Relocating the indoor and outdoor units	36
Using the stop valve	37
<b>Maintenance Procedures</b>	<b>38</b>
Performing the gas leak tests for repair	38
Decommissioning	38
<b>Appendix</b>	<b>40</b>
Troubleshooting	40

# Safety Information

California Proposition 65 Warning (US)

**⚠ WARNING:** Cancer and Reproductive Harm - [www.P65Warnings.ca.gov](http://www.P65Warnings.ca.gov).

**⚠ WARNING: Read This Manual**

- Read and follow all safety information and instructions before installation, use, or maintenance of this appliance. Incorrect installation, use, or maintenance of this appliance can result in death, serious injury, or property damage. Keep these instructions with this appliance. This manual is subject to change. For the latest version, visit [www.lennox.com](http://www.lennox.com).

**IMPORTANT** – This product has been designed and manufactured to meet ENERGY STAR criteria for energy efficiency when matched with appropriate coil components. However, proper refrigerant charge and proper air flow are critical to achieve rated capacity and efficiency. Installation of this product should follow the manufacturer's refrigerant charging and air flow instructions. Failure to confirm proper charge and airflow may reduce energy efficiency and shorten equipment life.

## Notices and notes

To make you aware of safety messages and highlighted information, we use the following notices and notes throughout this manual:

**⚠ WARNING**  
Hazards or unsafe practices may result in severe personal injury or death.







**⚠ CAUTION**  
Hazards or unsafe practices may result in minor personal injury or property damage.

**📖 IMPORTANT**

- Information of special interest

**📖 NOTE**

- Supplementary information that may be useful

Symbol	Meaning
	Flammable gas
	Flammable materials
	Refrigerant safety group
	Read installation manual
	Refer to installation manual
	Read service manual

**⚠ WARNING**

The installation and testing of this appliance must be performed by a qualified technician.

- The instructions in this manual are not intended as a substitute for proper training or adequate experience in the safe installation of the appliance.

Always install the mini-split in compliance with current local, state, and federal safety standards.

# Safety Information

## General information

### WARNING

- Carefully read the content of this manual before installing the mini-split and store the manual in a safe place to be able to use it as a reference after installation.
- For maximum safety, installers should always carefully read the following warnings.
- Store the operation and installation manual in a safe location and remember to hand it over to the new owner if the mini-split is sold or transferred.
- This manual explains how to install an indoor unit with a split system with two Lennox units. Using other types of units with different control systems may damage the units and invalidate the warranty. The manufacturer shall not be responsible for damages arising from the use of non-compliant units.
- The manufacturer shall not be responsible for damage originating from unauthorized changes or the improper connection of electricity and requirements outlined in the "Operating limits" table, included in the manual, shall immediately invalidate the warranty.
- The mini-split should be used only for the applications for which it has been designed: the indoor unit is not suitable to be installed in areas used for laundry.
- All pipe work including piping material, pipe routing, and installation shall include protection from physical damage in operation and service and comply with national and local codes and standards, such as ASHRAE 15, ASHRAE 15.2, IAPMO Uniform Mechanical Code, ICC International Mechanical Code, or CSA B52. Any field joints shall be accessible for inspection before being covered or enclosed.
- Do not use the units if damaged. If problems occur, switch the unit off and disconnect it from the power supply.
- To prevent electric shocks, fires or injuries, always stop the unit, disable the protection switch and contact Lennox's technical support if the unit produces smoke, if the power cable is hot or damaged or if the unit is very noisy.
- Always remember to inspect the unit, electric connections, refrigerant tubes and protections regularly. These operations should be performed by qualified personnel only.
- The unit contains moving parts, which should always be kept out of the reach of children.
- Do not attempt to repair, move, alter or reinstall the unit. If performed by unauthorized personnel, these operations may cause electric shocks or fires.
- Do not place containers with liquids or other objects on the unit.
- All the materials used for the manufacture and packaging of the mini-split are recyclable.
- The mini-split contains a refrigerant that must be disposed of as special waste. At the end of its life cycle, the mini-split must be disposed of in authorized centers or returned to the retailer so that it can be disposed of correctly and safely.
- Wear protective equipment (such as safety gloves, goggles, and headgear) during installation and maintenance work. Installation/repair technicians may be injured if improper protective equipment is worn.
- Do not use means to accelerate the defrost operation or to clean, other than those recommended by Lennox.
- Do not pierce or burn.
- Be aware that refrigerants may not contain an odor.
- This appliance is not intended for use by persons (including children) with reduced physical, sensory, or mental capabilities, or lack of experience and knowledge unless they have been given supervision or instruction concerning the use of the appliance by a person responsible for their safety. Children should be supervised to ensure that they do not play with the appliance.

## Installing the unit

### WARNING

**IMPORTANT:** When installing the unit, always remember to connect first the refrigerant tubes, and then the electrical lines.

- Connecting one indoor unit to this product is prohibited.
- Upon receipt, inspect the product to verify that it has not been damaged during transport. If the product appears damaged, DO NOT INSTALL it, and immediately report the damage to the carrier or retailer (if the installer or the authorized technician has collected the material from the retailer.)
- After completing the installation, always carry out a functional test and provide instructions on how to operate the mini-split to the user.
- Do not use the mini-split in environments with hazardous substances or close to equipment that releases free flames to avoid the occurrence of fires, explosions or injuries.
- Our units should be installed in compliance with the spaces shown in the installation manual, to ensure accessibility from both sides and allow repairs or maintenance operations to be carried out. The unit's components should be accessible and easy to disassemble without endangering people and objects.
- For this reason, when provisions of the installation manual are not complied with, the cost required to access and repair the units (in SAFETY CONDITIONS, as set out in prevailing regulations) with harnesses, ladders, scaffolding or any other elevation system will NOT be considered part of the warranty and will be charged to the end customer.
- Make sure that the condensed water runs well out of the unit at low ambient temperature. The base heater can frost/ice cannot grow. If drain work is not effective for releasing condensed water, it can make the units get damaged by massive ice and the system can be stopped, covered by ice. (MMLD020/024/030/036S6M-1P models)
- Do not disassemble and alter the heater at your discretion. (MMLD020/024/030/036S6M-1P models)
- The outdoor unit shall be installed in an open space that is always ventilated.
- Please adhere to the local gas regulations.
- To handle, purge, and dispose of the refrigerant, or to break into the refrigerant circuit, the technician should have a certificate from an industry-accredited authority.
- While in installation or relocation of the product, do not mix the refrigerant with other gases including air or unspecified refrigerant. Failure to do so may cause pressure increase to result in rupture or injury.
- Do not cut or burn the refrigerant container or piping.
- Use clean parts such as manifold gauge, vacuum pump, and charging hose for the refrigerant.
- Installation must be carried out by qualified personnel handling the refrigerant. Additionally, reference local and national regulations and laws.
- Be careful not to let foreign substances (lubricating oil, refrigerant, water, etc.) enter the pipes.
- When mechanical ventilation is required, ventilation openings shall be kept clear of obstruction.
- For disposal of the product, follow the local laws and regulations.
- Do not work in a confined place.
- The work area shall be secured to only allow access by the technician(s).
- The refrigerant pipes shall be installed in a position where there are no substances that may result in corrosion.
- The following checks shall be performed for installation:
  - The charge amount depends on the room size.
  - The ventilation devices and outlets are operating normally and are not obstructed.
  - Markings and signs on the equipment shall be visible and legible.
- Upon leakage of the refrigerant, ventilate the room. When the leaked refrigerant is exposed to flame, it may cause the generation of toxic gases.
- Make sure that the work area is safe from flammable substances.
- To purge air in the refrigerant pipes, be sure to use a vacuum pump.
- Note that the refrigerant has no odor.
- The units are not explosion proof so they must be installed with no risk of explosion.
- This product contains fluorinated gases that contribute to the global greenhouse effect. Accordingly, do not vent gases into the atmosphere.

# Safety Information

---

- For installation with handling the refrigerant(R-32), use dedicated tools and piping materials. The working pressure of R-32 is higher than R410A, so failure to use the dedicated tools and piping materials may cause rupture or injury. Furthermore, it may cause serious accidents such as water leakage, electric shock or fire.
- Servicing shall be performed as recommended by the manufacturer. In case other skilled persons are joined for servicing; it shall be carried out under the supervision of the person who is competent in handling flammable refrigerants.
- For servicing the units containing flammable refrigerants, safety checks are required to minimize the risk of ignition.
- Servicing shall be performed following the controlled procedure to minimize the risk of flammable refrigerants or gases.
- Do not install where there is a risk of combustible gas leakage.
- Do not place near heat sources
- Be cautious not to generate a spark as follows:
  - Do not remove fuses with power on.
- If the indoor unit is not R-32 compatible, an error signal appears and the unit will not operate.
- After installation, check for leakage. Toxic gas may be generated if it comes into contact with an ignition source such as a fan heater or stove.
- Never directly touch any accidental leaking refrigerant. It could result in severe wounds caused by frostbite.

## Preparation of fire extinguisher

---

- If flammable work is to be done, appropriate fire extinguishing equipment should be available.
- Have a dry CO<sub>2</sub> fire extinguisher adjacent to the charging area and workspace.

## Ignition source safety

---

- Make sure to store the units in a place without continuously operating ignition sources (for example, open flames, an operating gas appliance or an operating electric heater).
- The service technician shall not use any ignition sources with the risk of fire or explosion.
- Potential ignition sources shall be kept away from the work area where the flammable refrigerant can be released into the surrounding area.
- The work area should be checked to ensure that there are no flammable hazards or ignition risks. The “No Smoking” sign shall be attached.
- Under no circumstances shall potential sources of ignition be used while detecting refrigerant leaks.
- Make sure that the seals or sealing materials have not degraded.
- Safe parts are the ones with which the worker can work in a flammable atmosphere. Other parts may result in ignition due to leakage.
- Replace components only with parts specified by Lennox. Other parts may result in the ignition of refrigerant in the atmosphere from a leak.

---

## Area ventilation

---

- Make sure that the work area is well ventilated before performing hot work.
- Ventilation shall be made even during work.
- The ventilation should safely disperse any released gases and preferably expel them into the atmosphere.

---

## Leakage detection methods

---

- The leakage detector shall be calibrated in a refrigerant-free area.
- Make sure that the detector is not a potential source of ignition.
- The leakage detector shall be set to the LFL (lower flammability limit).
- The use of detergents containing chlorine shall be avoided for cleaning because the chlorine may react with the refrigerant and corrode the piping.
- If leakage is suspected, naked flames shall be removed.
- If a leakage is found while brazing, the entire refrigerant charge shall be recovered from the product or isolated (e.g. using shut-off valves). It shall not be directly released into the environment. Oxygen free nitrogen (OFN) shall be used for purging the system before and during the brazing process.
- The work area shall be checked with an appropriate refrigerant detector before and during work.
- Ensure that the leakage detector is appropriate for use with flammable refrigerants.

---

## Labeling

---

- The parts shall be labeled to ensure that they have been decommissioned and emptied of refrigerant.
- The labels shall note the date of application.
- Make sure that the labels are affixed on the system to notify it contains flammable refrigerant.

---

## Recovery

---

- When removing refrigerant from the system for servicing or decommissioning, it is recommended to remove the entire refrigerant charge.
- When transferring refrigerant into cylinders, make sure that only refrigerant recovery cylinders are used.
- All cylinders used for the recovered refrigerant shall be labeled.
- Cylinders shall be equipped with pressure relief valves and shut-off valves in a proper order.
- Empty recovery cylinders shall be evacuated and cooled before recovery.
- The recovery system shall operate normally according to the specified instructions and shall be suitable for refrigerant recovery.
- In addition, the calibration scales shall operate normally.
- Hoses shall be equipped with leak-free disconnect couplings.
- Before starting the recovery, check for the status of the recovery system and sealing state. Consult with the manufacturer if suspected.
- The recovered refrigerant shall be returned to the supplier in the correct recovery cylinders with the Waste Transfer Note attached.
- Do not mix refrigerants in the recovery units or cylinders.
- If compressors or compressor oils are to be removed, make sure that they have been evacuated to an acceptable level to ensure that flammable refrigerant does not remain in the lubricant.
- The evacuation process shall be performed before sending the compressor to the suppliers.
- Only the electrical heating of the compressor body is allowed to accelerate the process.
- Oil shall be drained safely from the system.

# Safety Information

- For installation with handling the refrigerant (R-32), use dedicated tools and piping materials. Because the pressure of the refrigerant, R-32, is approximately 1.6 times higher than that of R-22, failure to use the dedicated tools and piping materials may cause rupture or injury. Furthermore, it may cause serious accidents such as water leakage, electric shock, or fire.
- Never install motor-driven equipment to prevent ignition.

## Power supply line, fuse or circuit breaker

### WARNING

- Always make sure that the power supply is compliant with current safety standards. Always install the mini-split in compliance with current local safety standards.
- Always verify that a suitable grounding connection is available.
- Verify that the voltage and frequency of the power supply comply with the specifications and that the installed power is sufficient to ensure the operation of any other domestic appliance connected to the same electric lines.
- Always verify that the cut-off and protection switches are suitably dimensioned.
- Verify that the mini-split is connected to the power supply following the instructions provided in the wiring diagram included in the manual.
- Always verify that electric connections (cable entry, section of leads, protections...) are compliant with the electric specifications and with the instructions provided in the wiring scheme. Always verify that all connections comply with the standards applicable to the installation of mini-splits.
- Devices disconnected from the power supply should be completely disconnected in the condition of overvoltage category.
- Be sure not to perform power cable modification, extension wiring, and multiple wire connections.
  - It may cause electric shock or fire due to poor connection, poor insulation, or current limit override.

## Precautions for using R-32 refrigerant

### General

- This product is pre-charged with mildly flammable gas classified as A2L by ASHRAE. The following precautions and instruction manuals must be followed during installation, operation, servicing and decommissioning of the product.
- The appliance shall be stored in a room without continuously operating ignition sources, like open flames or a gas appliance or an electric heater.
- All national and local regulations shall be observed at all times.
- All pipe-work including piping material, pipe routing and installation shall include protection from physical damage in operation and service, and be in compliance with national and local codes and standards, such as ASHRAE 15, ASHRAE 15.2, IAPMO Uniform Mechanical Code, ICC International Mechanical Code, or CSA B52. All field joints shall be accessible for inspection prior to being covered or enclosed.
- All field piping and joints shall be pressure tested with an inert gas according to prevalent industry standards prior to refrigerant charging and system commissioning.
- Where additional field charging is required. The installer shall write with a permanent marker the field charge added on the ODU label provided, such that the Total Charge = Factory 'Pre-charge' + field charge.
- For ducted systems, any auxiliary systems that are potential ignition sources shall not be installed in the duct work. Examples of ignition sources are hot surfaces with temperatures exceeding 700°C and electric switching devices.
- Any auxiliary device installed must be approved by Lennox and must be suitable for operating with the refrigerant marked on the label.
- For mechanical ventilation the lower edge of the air extraction opening shall not be more than 100mm above the floor. The exhaust location outside the building must be at least 3 m away from the building opening and mechanical air intake openings.
- To handle, purge, and dispose of the refrigerant, or break into the refrigerant circuit, the worker should have a certificate from an industry-accredited authority.
- Non-ducted systems may be installed in areas such as false ceilings not being used as return air plenum if the conditioned air does not mix with the air in the false ceilings.



- For ducted appliances false ceiling or drop ceilings may be used as return air plenum if a refrigerant leak detection system is provided in the system and any external connections are also provided with a sensor immediately below the return air plenum duct joint.
- Installation, servicing and any type of maintenance or repair must be performed by certified personnel that are competent to carry out such activity in accordance with national and local regulations.

## General Information on Servicing

- Do not work in a confined space. Ensure adequate ventilation is provided at the workspace during the entirety of the duration of the work to safely disperse any released refrigerant.
- All maintenance staff and others working in the local area shall be instructed on the nature of the work being performed and instructed to follow all instructions provided by Lennox, national and local authorities.
- The area shall be checked with an approved refrigerant detector before and during any work on the system.
- Have a dry CO<sub>2</sub> fire extinguisher adjacent to the charging area and workspace.
- The service personnel shall not use any ignition sources in a manner that may lead to the risk of fire or explosion.
- Potential ignition sources shall be kept away from the work area where the flammable refrigerant can be released into the surrounding area.
- The work area should be checked to ensure that there are no flammable hazards or ignition risks. The "No Smoking" sign shall be attached.
- Under no circumstances shall potential sources of ignition be used upon detection of leakage.

The following checks shall be applied to installations and maintenance operations.

- The actual total refrigerant charge is in accordance with the room size in accordance with Table 1.
- The ventilation machinery and outlets are operating adequately and are not obstructed.
- Markings on the equipment are visible and legible.
- Refrigerant pipes or components are installed in a position where they are unlikely to be exposed to any substance that may corrode refrigerant-containing components.

Initial checks of electrical devices shall include the following.

- that capacitors are discharged in a safe manner to avoid sparking.
- that no live electrical components and wiring are exposed while charging, recovering or purging the system.
- That there is continuity to earth bonding.
- Check that the cabling is not worn, corroded or damaged in any manner.

## Electrical repair safety measures

- All electrical components used or replaced must be to Lennox's specifications.
- If a fault exists that could compromise safety, then no electrical supply shall be connected to the circuit until it is satisfactorily dealt with.
- Sealed electrical components and intrinsically safe components shall be replaced and not repaired.
- Cabling should be protected from excessive vibration, pressure, sharp edges, and other adverse environmental factors.

## Detection of flammable refrigerants

- Electronic leak detectors shall be used to detect flammable refrigerants, but the sensitivity may not be adequate or may need re-calibration. (Detection equipment shall be calibrated in a refrigerant-free area.)
- Make sure that the detector is not a potential source of ignition.
- Leak detection equipment shall be set at a percentage of the LFL (Lower flammable limit) of the refrigerant and shall be calibrated to the refrigerant employed and the appropriate percentage of gas (25% maximum) is confirmed.
- The use of detergents containing chlorine shall be avoided for cleaning because the chlorine may react with the refrigerant and corrode the piping.
- If leakage is suspected, naked flames shall be removed.
- If a leakage is found while brazing, the entire refrigerant shall be recovered from the product or isolated (e.g. using shut-off valves). It shall not be directly released into the environment. Oxygen-free nitrogen (OFN) shall be used for purging the system before and during the brazing process.
- The work area shall be checked with an appropriate refrigerant detector before and during work.
- Ensure that the leakage detector is appropriate for use with flammable refrigerants.

# Safety Information

---

## Removal and Evacuation

---

- When removing refrigerant for servicing it is recommended to remove the entire quantity.
- When removing refrigerant follow local and national regulations and follow best practices including;
  - evacuate;
  - purge the circuit with inert gas (optional for A2L);
  - evacuate (optional for A2L);
  - continuously flush or purge with inert gas when using a flame to open the circuit; and
  - open the circuit.
- Use proper recovery cylinders appropriate for the type of refrigerant.
- Follow prescribed industry best practices for purging and evacuation.
- Oxygen free nitrogen shall be used for purging the system.

## Charging procedure

---

- Follow industry standard refrigerant charging best practices.
- Before recharging the system, it shall be pressure tested with oxygen-free nitrogen gas.
- Ensure that contamination of different refrigerants does not occur when charging.
- Cylinders shall be kept in the appropriate position as per instructions.
- The refrigerant system should be grounded before charging the system.
- Label the system when charging is completed.
- Take extreme care not to overfill the refrigeration system.
- The system shall be leak tested on completion of charging before commissioning.

## Decommissioning

---

- Only qualified licensed professionals shall perform refrigerant recovery and decommissioning.
- Isolate the system electrically.
- All recovery equipment and cylinders shall conform to appropriate standards. Only approved cylinders, with pressure relief valves, for the type of refrigerant shall be used.
- Recover refrigerant following industry standard procedure for flammable refrigerants.
- When draining compressors oil care must be taken that there is no flammable refrigerant in the compressor and that the compressor is not hot. Oil should be handled according to local and federal regulations.
- After decommissioning, the system shall be labeled stating that it has been decommissioned. The label shall be dated and signed. The label should state that it "contains flammable refrigerant".
- Ensure that there are labels on the equipment indicating the equipment contains flammable refrigerant.
- Recovered refrigerant shall not be mixed or reused. It shall be processed according to national, state and local regulations.

# Installation Procedure

## Step 1 Choosing the installation location

### WARNING

- If appliances contain R-32 refrigerant, then the floor area of the room in which the appliances are installed, operated and stored must be larger than the minimum floor area defined in the table below A, [ft<sup>2</sup>(m<sup>2</sup>)].

<Table 1>

m [lbs(kg)]	Minimum required room area [A, ft <sup>2</sup> (m <sup>2</sup> )]			
	Reference Height [h <sub>0</sub> , ft(m)]			
	Ceiling-mounted			
	7.2(2.2)	8.2(2.5)	8.9(2.7)	10.5(3.2)
≤ 4.047(1.836)	- no room area restrictions -			
4.049(1.837)	58.7(5.46)	51.7(4.80)	47.9(4.45)	40.4(3.75)
4.18(1.9)	60.8(5.64)	53.5(4.97)	49.5(4.60)	41.8(3.88)
4.40(2.0)	64.0(5.94)	56.3(5.23)	52.1(4.84)	44.0(4.08)
4.85(2.2)	70.4(6.54)	61.9(5.75)	57.3(5.33)	48.4(4.49)
5.29(2.4)	76.7(7.13)	67.5(6.27)	62.5(5.81)	52.8(4.90)
5.73(2.6)	83.1(7.72)	73.2(6.80)	67.7(6.29)	57.2(5.31)
6.17(2.8)	89.5(8.32)	78.8(7.32)	73.0(6.78)	61.6(5.72)
6.61(3.0)	95.9(8.91)	84.4(7.84)	78.2(7.26)	66.0(6.13)
7.05(3.2)	102(9.51)	90.1(8.37)	83.4(7.75)	70.4(6.54)
7.49(3.4)	109(10.1)	95.7(8.89)	88.6(8.23)	74.7(6.94)
7.93(3.6)	115(10.7)	101(9.41)	93.8(8.71)	79.1(7.35)

m [lbs(kg)]	Minimum required room area [A, ft <sup>2</sup> (m <sup>2</sup> )]	
	Reference Height [h <sub>0</sub> , ft(m)]	
	Wall-mounted	<sup>1)</sup> Floor-standing
	5.91(1.8)	1.97(0.6)
≤ 4.047(1.836)	- no room area restrictions -	
4.049(1.837)	71.8(6.67)	215(20.0)
4.18(1.9)	74.3(6.90)	223(20.7)
4.40(2.0)	78.2(7.26)	235(21.8)
4.85(2.2)	86.0(7.99)	258(24.0)
5.29(2.4)	93.8(8.71)	281(26.1)
5.73(2.6)	102(9.44)	305(28.3)
6.17(2.8)	109(10.2)	328(30.5)
6.61(3.0)	117(10.9)	352(32.7)
7.05(3.2)	125(11.6)	375(34.9)
7.49(3.4)	133(12.3)	399(37.0)
7.93(3.6)	141(13.1)	422(39.2)

- m : Total refrigerant charge in the system
- A : Minimum required room area
- Calculated in accordance with UL 60335-2-40 Annex GG
- The actual refrigerant charge shall be per the room size within which the refrigerant-containing parts are installed.

<sup>1)</sup> For models with R-32 sensor

- The ventilation machinery and outlets shall be operating adequately and not obstructed.
- If an indirect refrigerating circuit is being used, the secondary circuit shall be checked for the presence of refrigerant.
- Marking the equipment shall continue to be visible and legible. Markings and signs that are illegible shall be corrected.
- Refrigerating pipe or components shall be installed in a position where they are unlikely to be exposed to any substance that may corrode refrigerant-containing components unless the components are constructed of materials that are inherently resistant to being corroded or are suitably protected against being so corroded.
- IMPORTANT:** It's mandatory to either follow the table above or follow the federal, state, and/or local regulations regarding the minimum room area allowed for the total refrigerant charge in the system.
- Minimum installation height depends on indoor unit specifications. Please refer to the indoor unit installation manual.

# Installation Procedure

## Installation location requirements

- The outdoor unit shall be installed in an open space that is always ventilated.
- All national, state, and local codes and regulations shall be observed.
- For installation inside a building (this applies either to indoor or outdoor units installed inside) a minimum room floor area of space conditioned is mandatory according to EN378-1:2017 (see the reference table in the indoor unit installation manual).
- To handle, purge, and dispose of the refrigerant, or to break into the refrigerant circuit, the technician should have a certificate from an industry-accredited authority.
- Do not install the mini-split in the following areas.
  - The place where there is mineral oil or arsenic acid. Resin parts flame and the accessories may drop or water may leak. The capacity of the heat exchanger may reduce or the mini-split may be out of order.
  - The place where corrosive gas such as sulfurous acid gas is generated from the vent pipe or air outlet. The copper pipe or connection pipe may corrode, and the refrigerant may leak.
  - The place where there is a machine that generates electromagnetic waves. The mini-split may not operate normally due to the control system.
  - The place where there is a danger of existing combustible gas, carbon fiber or flammable dust.
  - The place where animals may urinate on the product. Ammonia may be generated.
  - The place where thinner or gasoline is handled. Gas may leak and it may cause fire.
  - The place that is close to heat sources.
- Do not use the indoor unit for the preservation of food items, plants, equipment, and artwork. This may cause deterioration of their quality.
- Do not install the indoor unit if it has any drainage problems.
- Do not place the outdoor unit on its side or upside down. Failing to do so may cause the compressor lubrication oil to run into the cooling circuit and lead to serious damage to the unit.
- Install the unit in a well-ventilated location away from direct sunlight or strong winds.
- Install the unit in a location that would not obstruct any passageways or thoroughfares.

- Install the unit in a location that would not inconvenience or disturb your neighbors, as they could be affected by the noise or the airflow coming from the unit.
- Install the unit in a location where the pipes and the cables can be easily connected to the indoor unit.
- Install the unit on a flat, stable surface that can withstand the weight of the unit. Otherwise, the unit can generate noise and vibration during operation.
- Install the unit so that the air flow is directed towards the open area.
- Maintain sufficient clearance around the outdoor unit, especially from a radio, computer, stereo system, etc.

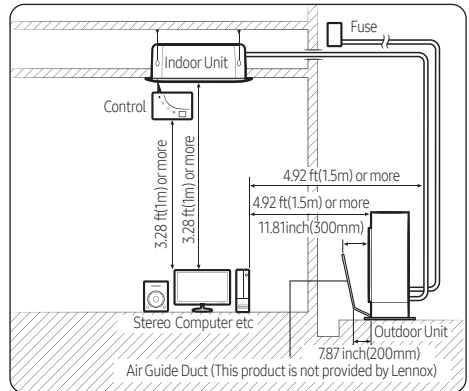

- Install the unit at a height where its base can be firmly fixed in place.
- Make sure that the water dripping from the drain hose runs away correctly and safely.

## ⚠ CAUTION

- You have just purchased a system mini-split and it has been installed by your installation specialist.
- This device must be installed according to the national electrical codes.
- If your outdoor unit exceeds a net weight of 132.2 lbs (60 kg), do not install it on a suspended wall, but stand it on the floor.
- The reliability of our product cannot be guaranteed when the ambient temperature is less than -13 °F (-25 °C).
- If the indoor unit is installed in an IT room (for example, a computer room), a separate backup system must be installed.

- When installing the outdoor unit at the seaside, make sure that it is not directly exposed to sea breeze. If you cannot find an adequate place free from direct sea breeze, construct a protection wall or a protective fence.
  - Install the outdoor unit in a place (such as near buildings etc.) where it can be protected from sea breeze. Failure to do so may cause damage to the outdoor unit.

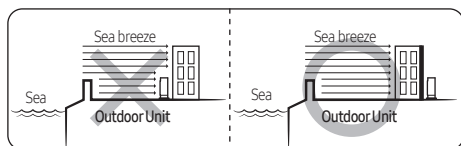

- If you cannot avoid installing the outdoor unit at the seaside, construct a protection wall around it to block the sea breeze.
- Construct a protection wall with a solid material such as concrete to block the sea breeze. Make sure that the height and the width of the wall are 1.5 times larger than the size of the outdoor unit. Also, secure a space larger than 27.6 inches (700mm) between the protection wall and the outdoor unit for exhausted air to ventilate.

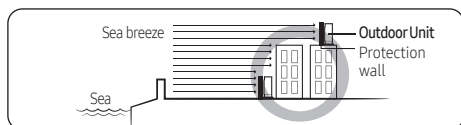

### ⚠ CAUTION

- Depending on the condition of the power supply, unstable power or voltage may cause malfunction of parts or control systems (for example : on a boat or places using power supplied from an electric generator, etc.).
- Install the unit in a place where water can drain smoothly.
- If you have any difficulty finding the installation location as prescribed above, contact your manufacturer for details.
- Consider that the salinity particles clinging to the external panels should be sufficiently washed out. Be sure to clean seawater and dust from the outdoor unit heat exchanger and apply a corrosion inhibitor on it at least once a year.

- Because the residual water at the bottom of the outdoor unit significantly promotes corrosion, make sure that the slope does not disturb drainage.
  - Keep the floor level so that rain does not accumulate.
  - Be careful not to block the drain hole due to foreign substances.
- Be sure to clean the heat exchanger and base plate of the outdoor unit regularly from any collected sand and salt.
- Touch up the additional protective coating (third party) if needed, at least once a year or according to the third party's product requirements
- Check the condition of the product periodically.
  - Check the installation site every 3 months and perform anti-corrosion treatment such as commercial water repellent grease and wax, etc., based on the product condition.
  - When the product is to be shut down for a long time, such as off-peak hours, take appropriate measures like covering the product.
- If the product is installed within 1640.4 ft (500 m) of the seashore, a special anti-corrosion treatment is required.
  - ✳ Please contact your local Lennox representative for further details.

### ⚠ CAUTION

- In areas with heavy snowfall, piled snow could block the air intake. To avoid this incident, install a frame that is higher than the estimated snowfall. In addition, install a snow-proof hood to prevent snow from piling on the outdoor unit.

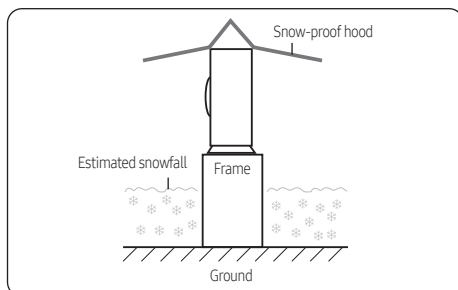

# Installation Procedure

## Minimum clearances for the outdoor unit

### When installing 1 outdoor unit

Unit : inch (mm)

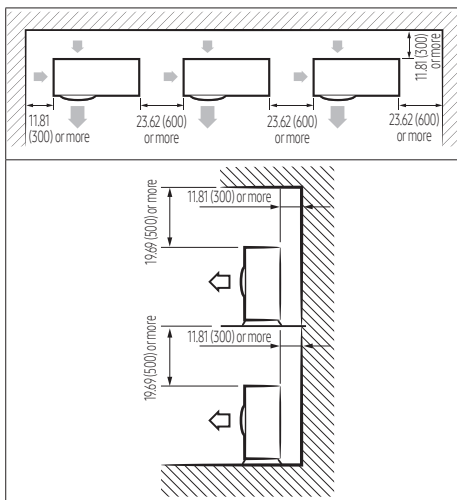
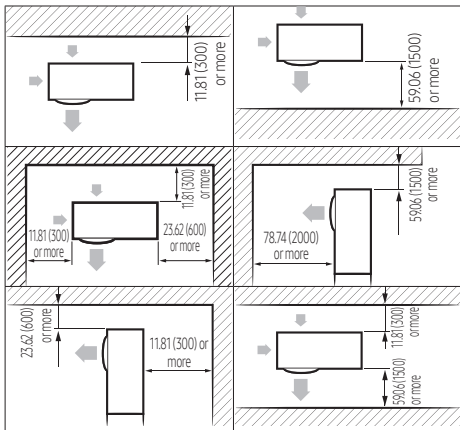

### When installing more than 1 outdoor unit



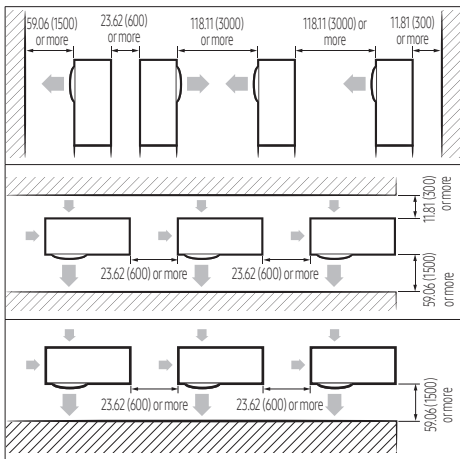







Unit : inch (mm)



## CAUTION

- The outdoor unit must be installed according to the specified clearance distances to permit accessibility from each side, and to guarantee correct operation, maintenance, and repair of the unit. The components of the outdoor unit must be accessible and removable under safe conditions for people and the unit.

## Step 2 Checking and preparing accessories and tools

3-wire Power Cable (option)	2-wire Assembly Cable (option)
	
Drain Plug	Energy Label
	
Rubber Leg	Installation Manual
	
Flare Nuts, 5/8 inch (15.88 mm) outer pipe diameter (MMLD030S6M-1P, MMLD036S6M-1P, MMPD036S6M-1P, MMPD048S6M-1P)	Flare Nuts, 3/8 inch (9.52 mm) outer pipe diameter (MMLD024S6M-1P, MMLD030S6M-1P, MMLD036S6M-1P, MMPD036S6M-1P, MMPD048S6M-1P)
	
Tube connector [Pipe 1/2 inch (12.7 mm), Bolt 3/8 inch (9.52 mm)] (MMLD024S6M-1P, MMLD030S6M-1P, MMLD036S6M-1P, MMPD036S6M-1P, MMPD048S6M-1P)	Tube connector [Pipe 1/2 inch (12.7 mm), Bolt 5/8 inch (15.88 mm)] (MMLD030S6M-1P, MMLD036S6M-1P, MMPD036S6M-1P, MMPD048S6M-1P)
	
Drain Cap	
	

### NOTE

- Wire assembly cables are optional. If they are not supplied, use standard cables.
- The drain plugs and the rubber legs are included only when the mini-split is supplied without assembly pipes.
- If these accessories are supplied, they are in the accessory package or outdoor unit package.

## Step 3 Fixing the outdoor unit in place

Install the outdoor unit on a rigid and stable base to prevent disturbance from any noise caused by vibration. When installing the unit on tall stands or in a location exposed to strong winds, fix the unit securely to the ground or structure.

- 1 Position the outdoor unit so that the air flow is directed towards the outside, as indicated by the arrows on the top of the unit.
  - Attach the outdoor unit to the appropriate support using anchor bolts.
- 2 The ground wire for the telephone line cannot be used to ground the mini-split.
- 3 If the outdoor unit is exposed to strong winds, install shield plates around the outdoor unit, so that the fan can operate correctly.

### NOTE

- Install provided rubber legs to prevent vibration and noise.

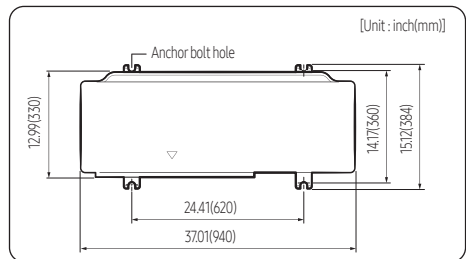

# Installation Procedure

## ⚠ CAUTION

- Install a drain outlet at the lowest end around the base for outdoor unit drainage.
- When installing the outdoor unit on the roof, waterproof the unit and check the ceiling strength.

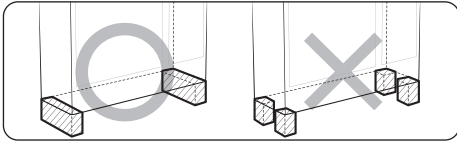

## Optional: Fixing the outdoor unit to a wall with a rack

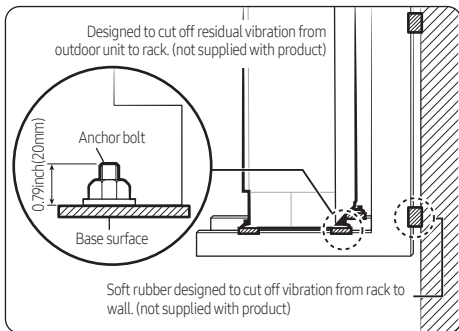

- Install a proper grommet to reduce noise and residual vibration transferred by the outdoor unit towards the wall.

## ⚠ CAUTION

- Make sure that the wall can support the weights of the rack and the outdoor unit.
- Install the rack as close to the column as possible.
- When installing an air guide duct, be sure to check the following:
  - The screws do not damage the copper pipe.
  - The air guide duct is fixed firmly on the guard fan.

## Step 4 Connecting the power cables, communication cable, and controllers

You must connect the following three electrical cables to the outdoor unit:

- The main power cable between the auxiliary circuit breaker and the outdoor unit.
- The outdoor-to-indoor power cable between the outdoor unit and the indoor unit.
- The communication cable between the outdoor unit and the indoor unit.

## ⚠ CAUTION

- During installation, first make the refrigerant connections and then the electrical connections. If the unit is being removed, first disconnect the electrical cables and then the refrigerant connections.
- Connect the mini-split to the earthing system before making the electrical connections.



## Connecting wire conduits

When connecting cables between the indoor unit and the outdoor unit, use conduits to protect the cables.

- 1 Remove the conduit plate from the product.
  - MMPD036S6M-1P

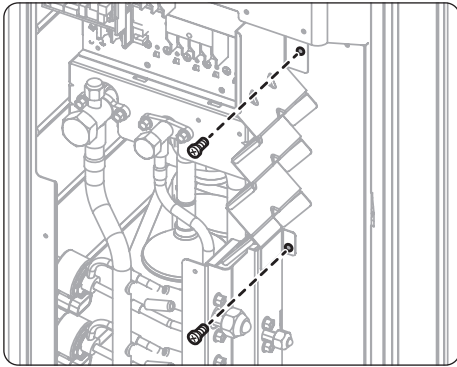

- MMLD020S6M-1P, MMLD024S6M-1P, MMLD030S6M-1P, MMLD036S6M-1P, MMPD048S6M-1P

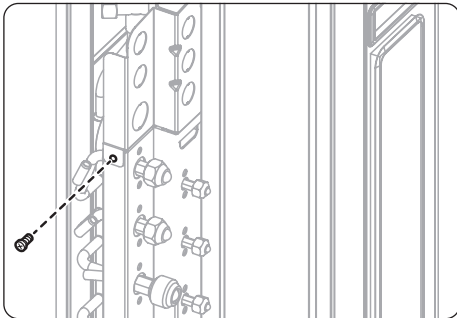

- 2 Remove conduit knock-outs for the required number of connections.
  - MMPD036S6M-1P

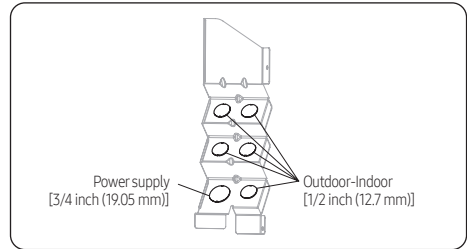

- MMLD020S6M-1P, MMLD024S6M-1P, MMLD030S6M-1P, MMLD036S6M-1P, MMPD048S6M-1P

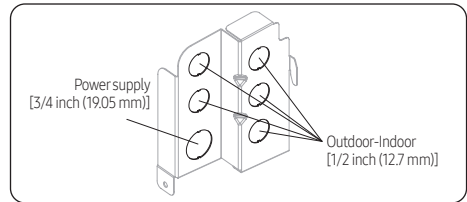

- 3 Insert the cables through the conduits, and then fix the conduits to the conduit plate with the lock nuts.
- 4 Apply silicone to the end of the hose to prevent rain from entering the hose.

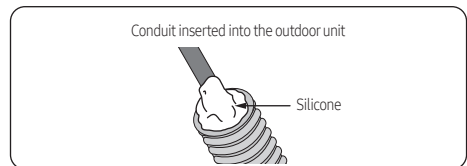

- 5 Connect the cables to the outdoor units. For how to connect the cables, refer to the next page.
- 6 Attach the conduit plate to the product.

# Installation Procedure

## Connecting the cables to the outdoor unit

- MMLD020S6M-1P

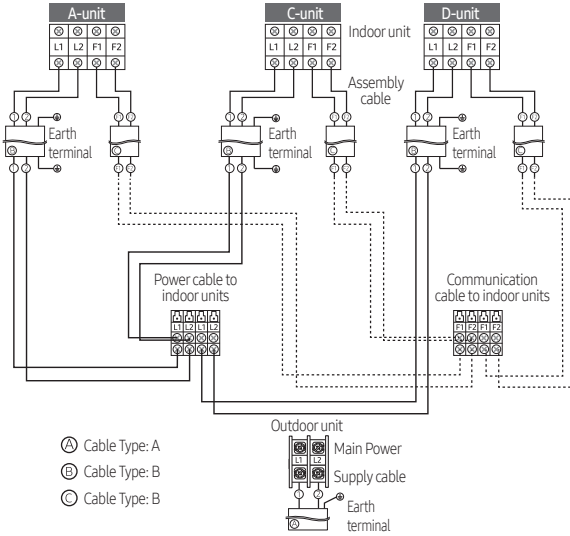

- MMLD024S6M-1P, MMLD030S6M-1P, MMLD036S6M-1P, MMPD036S6M-1P

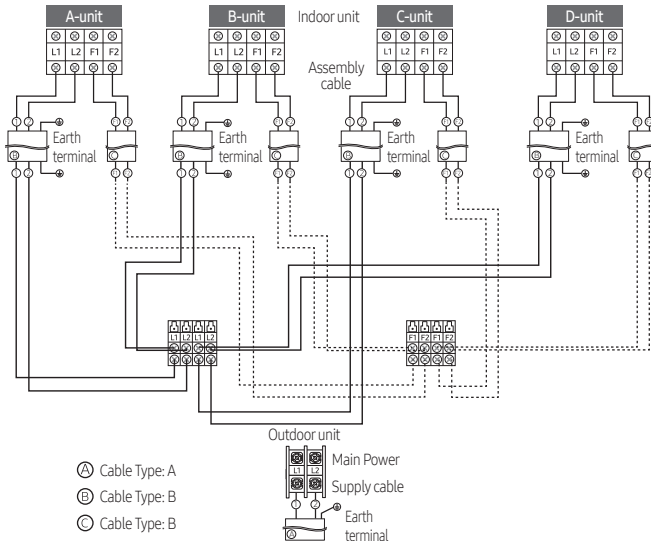

- MMPD048S6M-1P

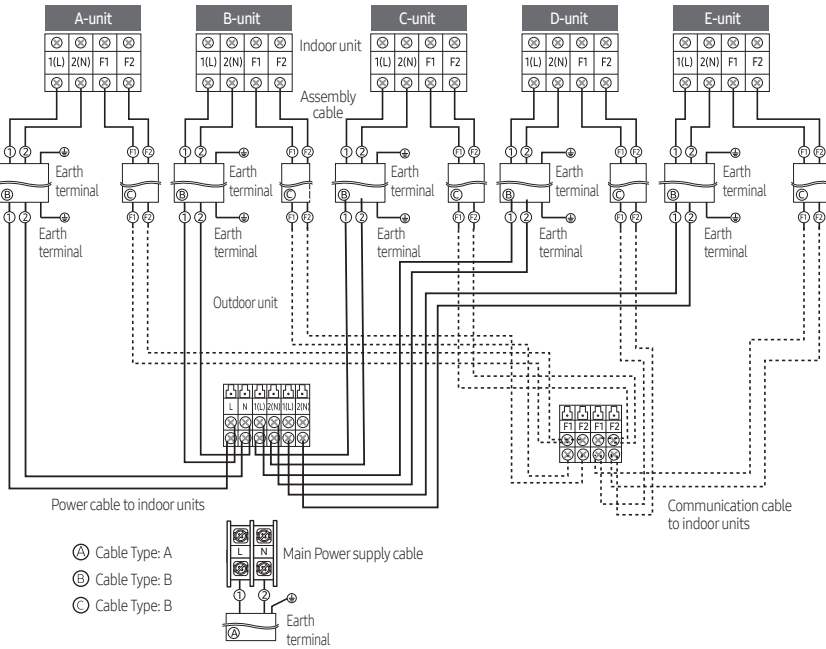

### ⚠ CAUTION

- You should connect the power cable to the power cable terminal and fasten it with a clamp.
- To protect the product from water and possible shock, you should keep the power cable and the connection cord of the indoor and outdoor units within ducts. (with appropriate IP rating and material selection for your application)
- Ensure that the main supply connection is made through a switch that disconnects all poles, with a contact gap of at least 0.12 inches(3mm).
- Devices disconnected from the power supply should be completely disconnected in the condition of overvoltage category.
- Keep distances of 1.97 inches(50 mm) or more between the power cable and communication cable. If a distance of 1.97 inches(50 mm) or more cannot be kept, a double shielded cable (FROHH2R or LiYCY type) must be used, connected to the earth on a single side.

# Installation Procedure

## Specification for circuit breaker and power supply cord

- Power supply cabling is not supplied with mini-split.
- Select the power supply cable following relevant local and national regulations.
- Wire size must comply with the applicable local and national codes.
- Specifications for local power cord wiring and branch wiring must comply with local codes.

## The specification for cables

Model	Main Power Supply Cable		Indoor Power Supply Cable		Communication Cable		FUSE	MCCB	Type GL
	Specification	Type	Specification	Type	Specification	Type			
MMPD036S6M-1P	3G, 4.0 mm <sup>2</sup> (8Kcmil or 0.0062 inch <sup>2</sup> or 10AWG), H05RN-F grade or more	A	3G, 1.5 mm <sup>2</sup> (3Kcmil or 0.0023 inch <sup>2</sup> or 14AWG), H05RN-F grade or more	B	2G, 0.75 mm <sup>2</sup> (1.5Kcmil or 0.0012 inch <sup>2</sup> or 18AWG), H05RN-F grade or more	C	30A	Frame: 35A Trip: 30A	30A
MMLD020S6M-1P, MMLD024S6M-1P, MMLD030S6M-1P, MMLD036S6M-1P, MMPD048S6M-1P	3G, 6.0 mm <sup>2</sup> (12Kcmil or 0.0093 inch <sup>2</sup> or 8AWG), H05RN-F grade or more						40A	Frame: 50A Trip: 40A	40A

- Connect the power cable to the auxiliary circuit breaker.  
An all-pole disconnection from the power supply must be incorporated in the fixed wiring with a contact opening of  $\geq 0.12$  inch (3 mm).

## Tightening power terminal

- Connect the cables to the terminal board using the compressed ring terminal.
- Use rated cables only.
- Connect the cables with driver and wrench that can apply the rated torque to the screws.
- Make sure that appropriate tightening torque is applied for cable connection. If the terminal is loose, arc heat may occur and cause fire and if the terminal is connected too firmly, terminal may get damaged.

Screw	Tighten Torque [lbf·ft (kgf·cm)]
M4	0.87 -1.30 (12.0 -18.0)

## Central control connection (optional)

PCB MAIN - OUT

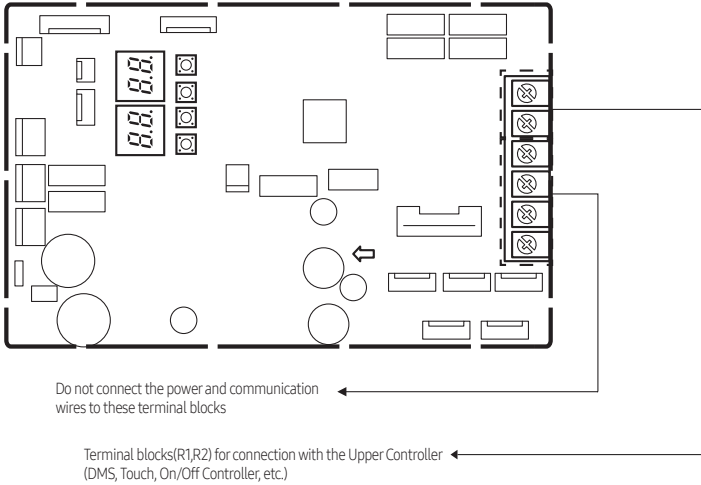

- 1 Turn the power off and take off the cover of the outdoor units.
- 2 Connect R1/R2 lines which are upper controller communication cables referring to upper figure. (Upper controller power should be off.)
- 3 Assemble a cover of the outdoor unit and turn the power on.
- 4 Check the communication status.
- 5 If you install a upper controller to the outdoor unit, every indoor unit which is connected to the outdoor unit can be controlled simultaneously.

# Installation Procedure

## Outdoor-to-indoor power terminal specifications

- Connect the cables to the terminal board using the compressed ring terminal.
- Cover a solderless ring terminal and a connector part of the power cable and then connect it.

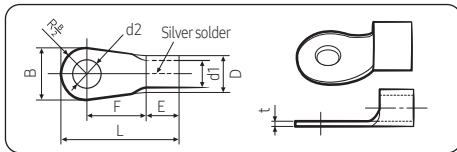

Nominal dimensions for cable [inch <sup>2</sup> /mm <sup>2</sup> ]	Nominal dimensions for screw [inch (mm)]	B		D		d1		E	F	L	d2		t
		Standard dimension [inch (mm)]	Allowance [inch (mm)]	Standard dimension [inch (mm)]	Allowance [inch (mm)]	Standard dimension [inch (mm)]	Allowance [inch (mm)]	Min. [inch (mm)]	Min. [inch (mm)]	Max. [inch (mm)]	Standard dimension [inch (mm)]	Allowance [inch (mm)]	Min. [inch (mm)]
0.002 (15)	0.15 (4)	0.260 (6.6)	±0.008	0.134 (3.4)	+0.012 (+0.3) -0.008 (-0.2)	0.067 (1.7)	±0.008 (±0.2)	0.161 (4.1)	0.236 (6)	0.630 (16)	0.169 (4.3)	+0.008 (+0.2) 0 (0)	0.028 (0.7)
		0.315 (8)	±0.008	0.165 (4.2)	+0.012 (+0.3) -0.008 (-0.2)	0.091 (2.3)	±0.008 (±0.2)	0.236 (6)	0.236 (6)	0.689 (17.5)	0.169 (4.3)	+0.008 (+0.2) 0 (0)	0.031 (0.8)
0.004 (2.5)		0.260 (6.6)	±0.008	0.165 (4.2)	+0.012 (+0.3) -0.008 (-0.2)	0.091 (2.3)	±0.008 (±0.2)	0.236 (6)	0.236 (6)	0.689 (17.5)	0.169 (4.3)	+0.008 (+0.2) 0 (0)	0.031 (0.8)
0.006 (4)		0.374 (9.5)	±0.008 (±0.2)	0.220 (5.6)	+0.012 (+0.3) -0.008 (-0.2)	0.134 (3.4)	±0.008 (±0.2)	0.236 (6)	0.197 (5)	0.787 (20)	0.169 (4.3)	+0.008 (+0.2) 0 (0)	0.035 (0.9)

- Connect the rated cables only.
- Connect using a driver which can apply the rated torque to the screws.
- If the terminal is loose, fire may occur caused by arc. If the terminal is connected too firmly, the terminal may be damaged.

	Tightening torque	
	lbf•ft	N•m
M4	0.87 to 1.30	1.2 to 1.8
M5	1.45 to 2.17	2.0 to 2.9

### ⚠ CAUTION

- When connecting cables, you can connect the cables to the electrical part or connect them through the holes below depending on the spot.
- Connect the communication cable between the indoor and outdoor units through a conduit to protect against external forces, and feed the conduit through the wall together with refrigerant piping.
- Remove all burrs at the edge of the knock-out hole and secure the cable to the outdoor knock-out using lining and bushing with electrical insulation such as rubber and so on.
- Must keep the cable in a protection tube.
- Keep distances of 1.97 inch(50mm) or more between power cable and communication cable.
- When the cables are connected through the hole, remove the knock-out piece.

## Outdoor-to-indoor power and communication cable specifications

Indoor power supply		
Power supply	Max/Min (V)	Indoor power cable
1Φ, 208-230V~, 60Hz	±10%	AWG14 ↑, 3 wires
Communication cable		
AWG18 ↑, 2 wires		

- Power supply cords of parts of appliances for outdoor use shall not be lighter than polychloroprene sheathed flexible cords. (Code designation IEC:60245 IEC 57 / CENELEC: H05RN-F)
- When installing the indoor unit in a computer room or network room, use the double shielded (tape aluminum / polyester braid + copper ) cable of FROHH2R or LIYCY type.

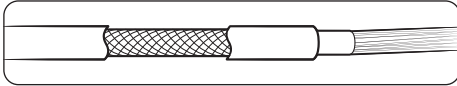

## Step 5 Connecting the refrigerant pipe

### MMLD020S6M-1P

#### 1 Piping outside diameter.

Indoor unit	Outdoor unit	Power supply Ø, V, Hz	Outside diameter	
			Liquid	Gas
**007/009/012**, MWMDO15M6-1P	MMLD020S6M-1P	1,208-230,60	1/4"	3/8"
**015**			1/2"	

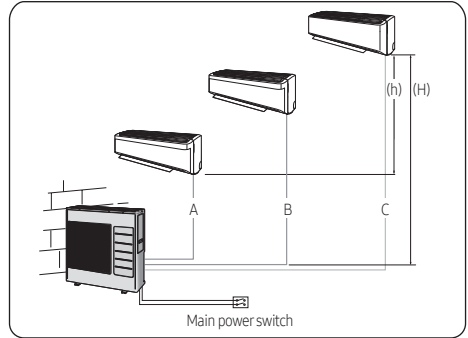

#### 2 Piping length and the height.

	1 Room max length	3 Room total max length	Max height between indoor unit & outdoor unit	Max height between indoor units
Dimension	82.0 ft (25 m)	229.7 ft (70 m)	49.2 ft (15 m)	24.6 ft (7.5 m)
Composition	A,B,C	A+B+C	(H)	(h)

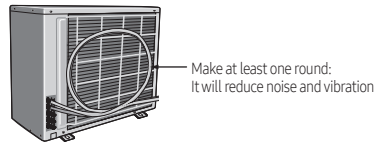

### ⚠ CAUTION

- Minimum pipe length is 10 ft (3 m) to reduce noise and vibration.
- The appearance of the unit may be different from the diagram depending on the model.

# Installation Procedure

## MMLD024S6M-1P

### 1 Piping outside diameter.

Indoor unit	Outdoor unit	Power supply $\phi$ , V, Hz	Outside diameter	
			Liquid	Gas
**007/009/012**, MWMD015M6-1P	MMLD024S6M-1P	1,208-230,60	1/4"	3/8"
**015**, **018**				1/2"
				5/8"

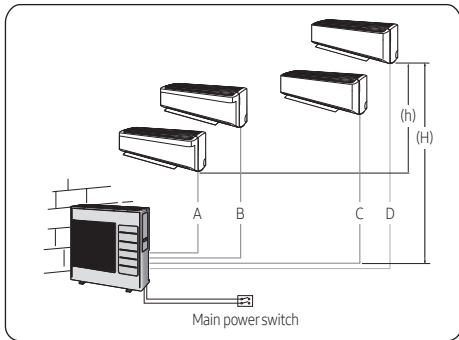

### 2 Piping length and the height.

	1 Room max length	3 Room total max length	Max height between indoor unit & outdoor unit	Max height between indoor units
Dimension	82.0 ft (25 m)	229.7 ft (70 m)	49.2 ft (15 m)	24.6 ft (7.5 m)
Composition	A,B,C	A+B+C	(H)	(h)

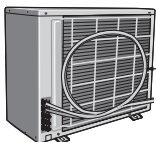

Make at least one round:  
It will reduce noise and vibration

### ⚠ CAUTION

- Minimum pipe length is 10 ft (3 m) to reduce noise and vibration.
- The appearance of the unit may be different from the diagram depending on the model.

## MMLD030S6M-1P / MMLD036S6M-1P / MMPD036S6M-1P

### 1 Piping outside diameter.

Indoor unit	Outdoor unit	Power supply $\phi$ , V, Hz	Outside diameter	
			Liquid	Gas
**007/009/012**, MWMD015M6-1P	MMLD030S6M-1P/ MMLD036S6M-1P/ MMPD036S6M-1P	1,208-230,60	1/4"	3/8"
**015**, **018**				1/2"
**024**				5/8"

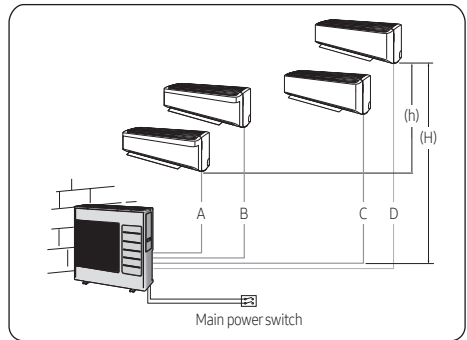

### 2 Piping length and the height.

	1 Room max length	3 Room total max length	Max height between indoor unit & outdoor unit	Max height between indoor units
Dimension	82.0 ft (25 m)	229.7 ft (70 m)	49.2 ft (15 m)	24.6 ft (7.5 m)
Composition	A,B,C	A+B+C	(H)	(h)

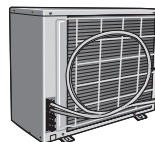

Make at least one round:  
It will reduce noise and vibration

### ⚠ CAUTION

- Minimum pipe length is 10 ft (3 m) to reduce noise and vibration.
- The appearance of the unit may be different from the diagram depending on the model.



## MMPD048S6M-1P

### 1 Piping outside diameter.

Indoor unit	Outdoor unit	Power supply Ø, V, Hz	Outside diameter	
			Liquid	Gas
**007/009/012** MWMDO15M6-1P	MMPD048S6M-1P	1,208-230,60	1/4"	3/8"
**015** , **018**				1/2"
**024**				5/8"

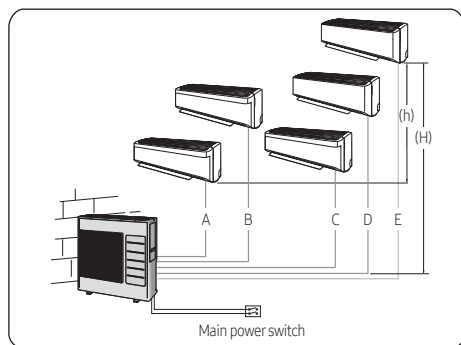

### 2 Piping length and the height.

	1 Room max length	3 Room total max length	Max height between indoor unit & outdoor unit	Max height between indoor units
Dimension	82.0 ft (25 m)	229.7 ft (70 m)	49.2 ft (15 m)	24.6 ft (7.5 m)
Composition	A,B,C	A+B+C	(H)	(h)

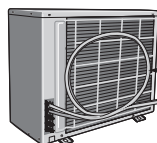

Make at least one round:  
It will reduce noise and vibration

## ⚠ CAUTION

- If the indoor unit combination includes MDDD\*\*\*M6-1P / MMD\*\*\*M6-1P indoor units, select a combination according to the guide in the Technical Data Book.
- If error code E563 occurs, Cool Mode Try run and Pipe Check operations are still possible.

## 📖 NOTE

- You can use the Cool and Heat modes in the following conditions :

Mode	Cool	Heat	
		MMPD***S6M-1P	MMLD***S6M-1P
Outdoor temperature	14 °F to 114.8 °F (-10 °C to 46 °C)	5 °F to 75.2 °F (-15 °C to 24 °C)	-13 °F to 75.2 °F (-25 °C to 24 °C)

- It could take maximum 60 minutes to operate for the protection of the compressor, if the outdoor temperature is below 23 °F (-5 °C).

## ⚠ CAUTION

- Minimum pipe length is 10 ft (3 m) to reduce noise and vibration.
- The appearance of the unit may be different from the diagram depending on the model.

# Installation Procedure

## Step 6 Optional: Cutting and flaring the pipes

- 1 Make sure that you have the required tools available. (pipe cutter, reamer, flaring tool, and pipe holder)
- 2 If you wish to shorten the pipes, cut them with a pipe cutter, taking care to ensure that the cut edge remains at a 90° angle with the side of the pipe. Refer to the illustrations below for examples of edges cut correctly and incorrectly.

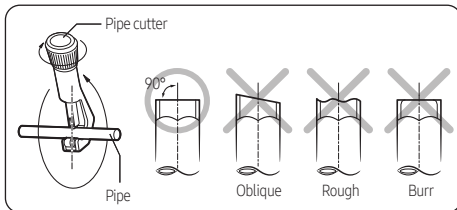

- 3 To prevent any gas from leaking out, remove all burrs at the cut edge of the pipe, using a reamer.
- 4 Slide a flare nut on the pipe and create the flare.

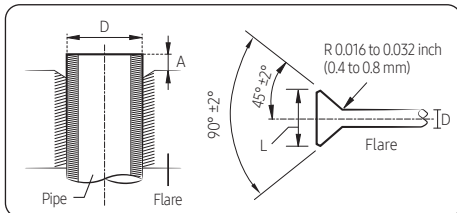

Outer Diameter (D)		Depth (A)		Flare dimension (L)	
mm	inch	mm	inch	mm	inch
Ø6.35	1/4	1.3	0.051	8.7 to 9.1	0.34 to 0.36
Ø9.52	3/8	1.8	0.071	12.8 to 13.2	0.50 to 0.52
Ø12.70	1/2	2.0	0.079	16.2 to 16.6	0.64 to 0.65
Ø15.88	5/8	2.2	0.087	19.3 to 19.7	0.76 to 0.78

- 5 Check that the flaring is correct, refer to the illustrations below for examples of incorrect flaring.

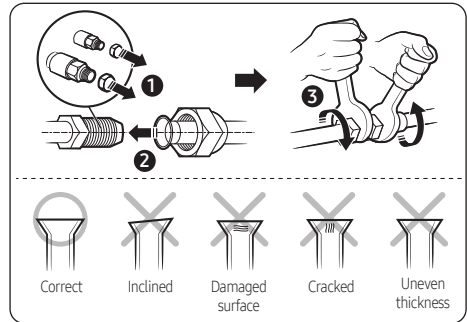

### ⚠ CAUTION

- When connecting the pipes, make sure that surrounding objects do not interfere with or contact them to prevent refrigerant leakage due to physical damage.
- Make sure that the spaces where the refrigerant pipes are installed comply with all national, state, and local regulations.
- Be sure that the area where pipe brazing is well ventilated.
- Be sure that when performing brazing and mechanical connections the refrigerant does not circulate.
- When reconnecting the pipes, make sure to perform flared-jointing newly to prevent refrigerant leakage.
- When working on the refrigerant pipes and the flexible refrigerant connectors, be careful that they are not damaged physically by surrounding objects.
- For installation with handling the R-32 refrigerant, use the special tools for the R-32 refrigerant (manifold gauge, vacuum pump, charging hose, etc.).
- During tests never pressurize the appliances with a pressure higher than the maximum allowable pressure (as indicated on the nameplate of the unit).
- Never directly touch any accidental leaking refrigerant. This could result in severe wounds caused by frostbite.
- Never install a dryer on this unit to guarantee its lifetime.
- If the pipes require brazing, ensure that OFN (Oxygen Free Nitrogen) is flowing through the system.
- The nitrogen blowing pressure range is 2.9 to 7.3 psi (0.02 to 0.05 MPa).
- While removing burrs, put the pipe face down to make sure that the burrs do not get into the pipe.

## Step 7 Connecting up and removing air in the circuit

### ⚠ CAUTION

- When installing, make sure there is no leakage. When recovering the refrigerant, ground the compressor first before removing the connection pipe. If the refrigerant pipe is not properly connected and the compressor works with the service valve open, the pipe inhales the air and it makes the pressure inside of the refrigerant cycle abnormally high. It may cause an explosion and injury.

The outdoor unit is loaded with sufficient R-32 refrigerant. Do not vent R-32 into the atmosphere: it is a fluorinated greenhouse gas, covered by the Kyoto Protocol, with a Global Warming Potential (GWP) = 675.

You should purge the air in the indoor unit and the pipe. If air remains in the refrigerant pipes, it affects the compressor. It may cause a reduction of cooling/heating capacity and malfunction. Use a Vacuum Pump as seen in the picture.

- Connect each assembly pipe to the appropriate valve on the outdoor unit and tighten the flare nut.
- Referring to the illustration below, tighten the flare nut on section D first by hand and then with a torque wrench, applying the following torque.

Outer Diameter (D)	Torque [lbf·ft(N·m)]
ø1/4"(6.35mm)	10.3~13.3(14~18)
ø3/8"(9.52mm)	25.1~31.0(34~42)
ø1/2"(12.70mm)	36.1~45.0(49~61)
ø5/8"(15.88mm)	50.2~60.5(68~82)

- Connect the charging hose of the low pressure side of the manifold gauge to the packed valve having a service port as shown in the figure.

Model Name	Valve	
	3/8"	1/2"
MMLD020S6M-1P	3	-
MMLD024S6M-1P	2	2
MMLD030S6M-1P		
MMLD036S6M-1P		
MMPD036S6M-1P		
MMPD048S6M-1P		
		3

### ⚠ CAUTION

- The designs and shapes are subject to change according to the model.

- Open the valve of the low pressure side(A) of the manifold gauge counterclockwise.

### ⚠ CAUTION

- Make the electrical connection and leave the system into "stand by mode". Do not turn on the system! This is necessary for better vacuum operation (full OPEN position of Electronic Expansion Valve - EEV -).

Tightening torque for body cap (Refer to the table)

Vacuum Pump

Spindle

Charging core

Tightening torque for charging port cap (Refer to the table)

R-32: Diameter of the screw-1/2-20UNF

# Installation Procedure

- 5 Purge the air from the system using a vacuum pump for about 10 minutes.
  - 1) Evacuate until 4000 microns is achieved, for at least 10 minutes.
  - 2) Close the gauge manifold valve, shut off the vacuum pump, and remove the common hose.
  - 3) Connect the hose to the nitrogen pressure regulator and bleed the hose by opening the end of the common hose closest to the manifold.
  - 4) Open the high-pressure manifold valve and slowly bring the system pressure to the atmosphere (101 kPa (14.64 psi)).
  - 5) Close the manifold and nitrogen cylinder and remove the common hose.
  - 6) Reconnect the common hose to the vacuum pump. Repeat steps 1) through 6), alternating between breaking the vacuum with dry nitrogen and evacuating, until system evacuation has occurred three times, to the following vacuum levels: Evacuation Microns

Evacuation	Microns
First	4000
Second	2000
Third	500

- 7) After evacuating to at least 500 microns for the third time, close the gauge manifold valve and wait 10 minutes, making sure that the vacuum level in the system does not decrease. If it does, a small leak is likely. Repair the leak and repeat the evacuation process.
- 6 Remove the hose of the low pressure side of the manifold gauge.
- 7 Open the stop valve of both liquid and gas sides.
- 8 Mount the valve stem nuts and the service port cap to the valve, and tighten them with a torque wrench.

Outer Diameter [inch (mm)]	Tightening torque	
	Body cap [(lbf-ft (N•m))]	Charging port cap [(lbf-ft (N•m))]
Φ1/4 (Ø 6.35)	14.8 to 18.4 (20 to 25)	7.4 to 8.9 (10 to 12)
Φ3/8 (Ø 9.52)		
Φ1/2 (Ø 12.70)		
Φ5/8 (Ø 15.88)		

## Step 8 Performing the gas leak test

Before completing the installation (insulation of the cables, hose and piping and fixing of the indoor unit to the installation plate), you must check that there are no gas leaks.

To check for gas leaks on the...	Then, using a leak detector, check the...
Outdoor unit	Valves on sections A and B.
Indoor unit	Flare nuts at the end of sections C and D.

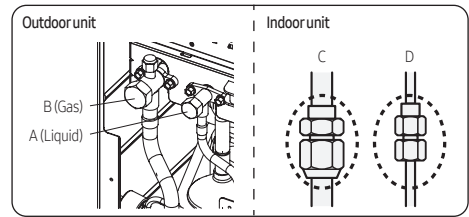

- The designs and shape are subject to change according to the model.

### LEAK TEST WITH NITROGEN (before opening valves)

In order to detect basic refrigerant leaks, before recreating the vacuum and recirculating the R-32, it is the responsibility of the installer to pressurize the whole system with nitrogen (using a cylinder with pressure reducer) at a pressure 4.1 MPa (595 psi).

### LEAK TEST WITH R-32 (after opening valves)

Before opening valves, discharge all the nitrogen into the system and create vacuum. After opening valves check leaks using a leak detector for refrigerant R-32.

Once you have completed all the connections, check for possible leaks using leak detector specifically designed for HFC refrigerants.

## Step 9 Charging refrigerant (R-32)

### Precautions on charging R-32 refrigerant

In addition to the conventional charging procedure, the following requirements shall be kept.

#### ⚠ CAUTION

- Make sure that contamination by other refrigerants does not occur for charging.
- To minimize the amount of refrigerant, keep the hoses and lines as short as possible.
- The cylinders shall be kept upright.
- Make sure that the refrigeration system is earthed before charging.
- Label the system with the final system charge with indelible ink.
- Extreme care is required not to overcharge the system.
- If the system must be evacuated for any reason, before recharging system tightness must be checked with nitrogen.
- After charging, check for leakage before commissioning.
- Be sure to check for leakage before leaving the work area.

#### ⚠ CAUTION

Please fill in the following with indelible ink on the refrigerant charge label supplied with this product and on this manual.

- ① the factory refrigerant charge of the product,
- ② the additional refrigerant amount charged in the field and
- ① + ② the total refrigerant charge. on the refrigerant charge label supplied with the product.

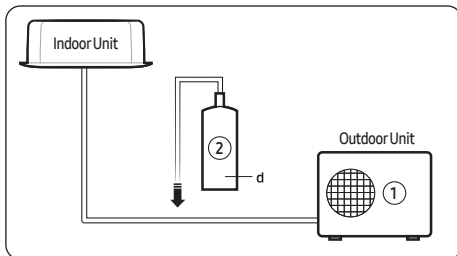

Unit	oz(g)
①, a	
②, b	
① + ②, c	

#### 📖 NOTE

- a Factory refrigerant charge of the product: see unit nameplate
- b Additional refrigerant amount charged in the field (Refer to the above information for the quantity of refrigerant replenishment.)
- c Total refrigerant charge
- d Refrigerant cylinder and manifold for charging

#### ⚠ CAUTION

- Do not add refrigerant regardless of installation conditions for these models.
- In both cases, when you use a pipe longer or shorter than the length specified in the piping codes and standard, do not add or remove refrigerant.

Model	Maximum allowable pipe length	Maximum refrigerant charging	Factory refrigerant charging
MMLD020S6M-1P	229.7ft (70m)	109.3oz (3100g)	109.3oz (3100g)
MMPD036S6M-1P	229.7ft (70m)	95.2oz (2700g)	95.2oz (2700g)
MMLD024S6M-1P	229.7ft (70m)	109.3oz (3100g)	109.3oz (3100g)
MMLD030S6M-1P	229.7ft (70m)	109.3oz (3100g)	109.3oz (3100g)
MMLD036S6M-1P	229.7ft (70m)	109.3oz (3100g)	109.3oz (3100g)
MMPD048S6M-1P	229.7ft (70m)	109.3oz (3100g)	109.3oz (3100g)

# Installation Procedure

## Step 10 Connecting the drain hose to the outdoor unit

- When using the mini-split in the heating mode, ice may accumulate. During de-icing (defrost operation), the condensed water must be drained off safely. Consequently, you must install a drain hose on the outdoor unit, following the instructions below. (For MMLD\*\*\*S6M-1P model, do not install a drain hose and a drain plug.)
- Make space more than 3.15 inches (80 mm) between the bottom of the outdoor unit and the ground for the installation of the drain hose, as shown in the figure.
  - Insert the drain plug into the hole on the underside of the outdoor unit.
  - Connect the drain hose to the drain plug.
  - Ensure that the drained water runs off correctly and safely. If needed apply a heating cable to prevent freezing of the drain hose/ pipe.

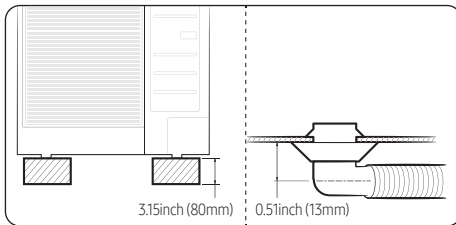

- Be sure to plug the rest of the drain holes not connected with drain plugs using drain caps.

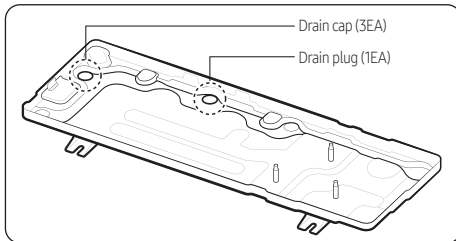

- When installing the product, make sure that the rack is not placed under the drain hole.
- If the product is installed in a region of heavy snow, allow enough separation distance between the product and the ground.

## ⚠ CAUTION

- For the MMLD\*\*\*S6M-1P model, do not install a drain hose, a drain plug, or a drain cap. (Let the water drain naturally.)
- Ice may form on the ground. Take appropriate measures to prevent ice formation.

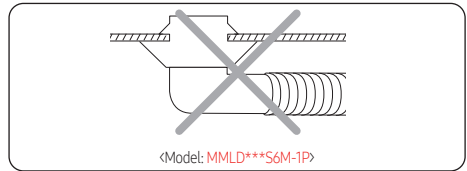

## Step 11 Checking the grounding

If the power distribution circuit does not have a ground or the grounding does not comply with specifications, a grounding electrode must be installed according to the applicable national, state, and local code requirements. The corresponding accessories are not supplied with the mini-split.

## Step 12 Setting an indoor unit address and installation option

### Setting the indoor unit addresses manually

- Review all the following elements in the installation:
  - Installation site strength
  - Piping connection tightness to detect any gas leakage
  - Connection wiring
  - Heat-resistant insulation of the piping
  - Drainage
  - Earthing wire connection
- Manually set options in each room's the indoor unit by referring to page 34-35.
- Press the K3 button once or reset the outdoor unit.

## 📖 NOTE

- The Display 1/2 indications are the same as in the automatic address setting mode.

## Setting Key and Display of the outdoor unit

- Key option of the outdoor unit
  - K1: Function button
  - K3: Reset button

Key / Push	K1	K3
1	Pipe Checking Operation	Reset
2	Cool Mode Try run	
3	Heat Mode Try run	
4	Pump Down	
5	Inverter Fault Detection (Comp#1) <sup>1)</sup>	
6	Auto Mode Try run	
7	Finish Key Operation	

<sup>1)</sup> Indication on the display and action to take when an inverter fault is detected

	SEG1	SEG2	SEG3	SEG4	Action to take
Fault detection is in progress	8	8	8	8	-
OK	8	8	0	8	-
NG	8	8	8	0	PBA defect: Replace the PBA
Check	8	8	0	8	Manual inspection is required
Going into fault detection mode failed	8	8	8	0	Try fault detection again

※ For more information of the Cool or Heat or Auto mode Try run test, refer to page 35.

- K4 View mode Display changes

Push	Display Explanation	Push	Display Explanation
1	Present Compressor Frequency	9	Discharge temperature
2	Target Compressor Frequency	10	OLP temperature
3	EEV0 current step	11	Condenser temperature
4	EEV1 current step	12	Outdoor temperature
5	EEV2 current step	13	Running current
6	EEV3 current step	14	Target Discharge temperature
7	EEV4 current step	15	Total capacity of the indoor units
8	Fan RPM (H: high, L: low, Blank: off)	16	Safety Control (just For Service Technician)

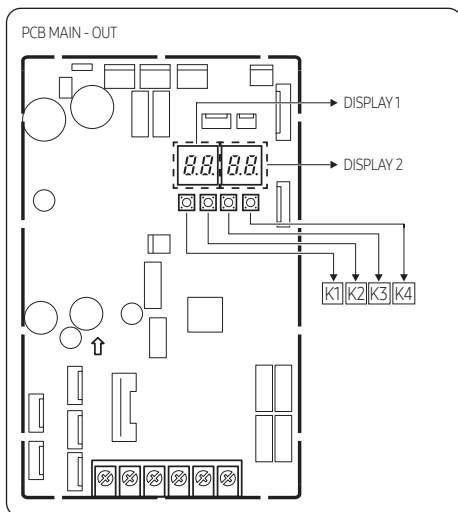

# Installation Procedure

## Setting the outdoor option

- Press and hold K2 to enter the option setting.  
(Only available when the operation is stopped)
  - If you enter the option setting, display will show the following.

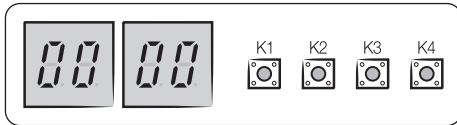

- Seg 1 and Seg 2 will display the number for selected option.
  - Seg 3 and Seg 4 will display the number for set value of the selected option.
- If you have selected desired option, you can shortly press the K1 switch to adjust the value of the Seg 1, Seg 2 and change the function for the selected option.

Example)

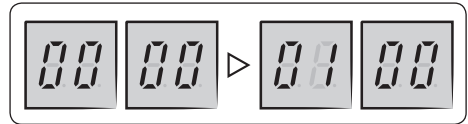

- If you have selected desired option, you can shortly press the K2 switch to adjust the value of the Seg 3, Seg 4 and change the function for the selected option.

Example)

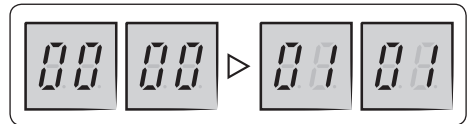

- After selecting the function for options, press and hold the K2 switch for 2 seconds. Edited value of the option will be saved when entire segments blinks and tracking mode begins.

Option item	Input unit	SEG1	SEG2	SEG3	SEG4	Function
Setting to Cool or Heat only mode	Main	0	0	0	0	Cooling and Heating (Factory default)
				0	1	Only Cooling
				0	2	Only Heating
Unused option	Main	0	1	0	0	Unused option
				0	1	Unused option
Mixed mode indoor input	Main	0	2	0	0	Disabled (Factory default)
				0	1	Enabled
Auto Change Over	Main	0	3	0	0	Disabled
				0	1	Enabled (Factory default)
Channel address	Main	0	4	A	U	Automatic setting (Factory default)
				00 ~ 15		Manual setting

## ⚠ CAUTION

- Edited option will not be saved if you do not end the option setting as explained in above instruction.
  - ※ While you are setting the option, you may press and hold the K1 button to reset the value to previous setting.
  - ※ If you want to restore the setting to factory default, press and hold the K4 button while you are in the option setting mode.
    - If you press and hold the K4 button, setting will be restored to factory default but it doesn't mean that restored setting is saved. Press and hold the K2 button. When the segments shows that tracking mode is in progress, setting will be saved.



## Setting the indoor unit addresses automatically

### NOTE

- For the best results, make sure that electrical wiring is done properly.
- For the best results, the outdoor temperature should be between 41 to 104 °F (\*) and the indoor temperature 60.8 °F or higher (\*).
  - ※ (\*) Auto addressing may fail when the temperature is out of the range above. In this case, set the address manually.

### CAUTION

- Connecting one indoor unit to this product is prohibited. Don't use pipe checking operation and auto addressing mode when only one indoor unit is installed.

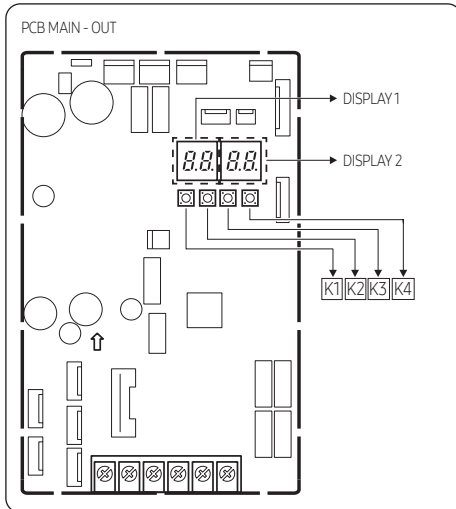

- Turn on the outdoor unit, and then check whether the display 1/2 indications are displayed "E199" code.
  - ※ During the initial, display 1 shows "Rd" and display 2 shows the connected indoor number.
    - If different display code is shown, see Troubleshooting on page 40 and take corrective actions.
- Push once the K1 button.
- After the operations described above have been performed, the system starts in Cooling or Heating mode, depending on the external ambient temperature. After a few minutes (from a minimum of 3 to 5 minutes for the internal unit), the system stops automatically, completing the self-test and addressing procedure. "t IoT" appears on the display of the outdoor unit.
- If you press the K1 button one more time, "t IoT" disappears and inspection is complete.

### NOTE

- At this point it is possible to start the indoor units in the desired mode.
  - ※ If "t IoT" doesn't display, the procedure has failed and it is therefore necessary to read ALL the operator's manual before repeating the operating described in steps 1-2-3-4.

# Installation Procedure

## Setting an indoor unit address (MAIN/RMC)

### NOTE

- Refer to the indoor unit installation manual for details on how to configure setting options.
- Check whether power is supplied or not.
    - When the indoor unit is not plugged in, there should be additional power supply in the indoor unit.

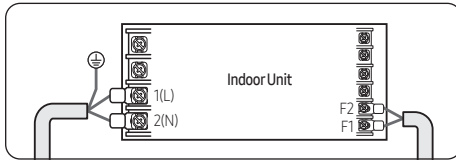

- The panel (display) should be connected to an indoor unit to receive option.
- Before installing the indoor unit, assign an address to the indoor unit according to the air conditioning system plan.
- Assign an indoor unit address by wireless remote controller.
  - The initial setting status of indoor unit ADDRESS(MAIN/RMC) is "0A0000-100000-200000-300000"
  - There is no need to assign extra ADDRESS for 1:1 installation between indoor unit and outdoor unit.

Option No. : 0AXXXX-1XXXXX-2XXXXX-3XXXXX

Option	SEG1		SEG2		SEG3		SEG4		SEG5		SEG6	
Explanation	Page		Mode		Setting main address		100-digit of indoor unit address		10-digit of indoor unit		A single digit of indoor unit	
Indication and details	Indication	Details	Indication	Details	Indication	Details	Indication	Details	Indication	Details	Indication	Details
	0		A		0	No Main address	0-9	100-digit	0-9	10-digit	0-9	A single digit
				1	Main address setting mode							
Option	SEG7		SEG8		SEG9		SEG10		SEG11		SEG12	
Explanation	PAGE				Setting RMC address				Group channel (*16)		Group address	
Indication and Details	Indication	Details	Indication	Details	Indication	Details	Indication	Details	Indication	Details	Indication	Details
	1				0	No RMC address			RMC1	1-F	RMC2	1-F
				1	RMC address setting mode							

※ You must set RMC address setting mode when using the centralized Control.

## ⚠ CAUTION

- When "A"~"F" is entered to SEG 4~6, the indoor unit MAIN ADDRESS is not changed.
  - If you set the SEG 3 as 0, the indoor unit will maintain the previous MAIN ADDRESS even if you input the option value of SEG 4~6.
  - If you set the SEG 9 as 0, the indoor unit will maintain previous RMC ADDRESS even if you input the option value of SEG 11~12.
- 5 The MAIN address is for communication between the indoor unit and the outdoor unit. Therefore, you must set it to operate the mini-split properly.

## Step 13 Cool and Heat modes operation test

After installing the outdoor and indoor units, test the **Cool** and **Heat** modes.

- When you test the **Cool** mode, set the set temperature of the indoor unit to the lowest setting. And when you test the **Heat** mode, set the set temperature of the indoor unit to the highest setting.
- Check if each indoor unit operates normally and then also check if all indoor units operate normally together.
  - Check both of the Cool and Heat modes.
- About 20 minutes after the mini-split is started, check the temperature difference between the air inlet and outlet of the indoor unit. If the temperature difference is larger than the value given in the following table, the operation is normal.

Mode	Temperature
Cool	Approximately 14.4 °F (8 °C)
Heat	Approximately 21.6 °F (12 °C)

## ⚠ CAUTION

- If the outdoor unit is turned off and then immediately turned on again, the compressor does not operate for about 3 minutes.
- During the Cool mode, frost may temporarily develop on valves and other parts.

## 📄 NOTE

- You can also test the Cool or Heat Try run using K1 button.
  - Cool mode try-run: Push the [K1] button twice.
  - Heat mode try-run: Push the [K1] button three times.
  - Auto mode try-run: Push the [K1] button six times. Automatically select mode according to outdoor temperature.

## Step 14 Optional: Setting to Cool or Heat only mode

This function enables the indoor units connected to the outdoor unit to operate in a specific mode.

You can set each mode with Keys on the Main PCB in the outdoor unit.

Set mode	SEG1	SEG2	SEG3	SEG4
Cooling and Heating	0	0	0	0
Only Cooling			0	1
Only Heating			0	2

- Default value: Cooling and Heating mode

# Extra Procedures

## Pumping down refrigerant

### WARNING

- After installing the product, perform a leak test on the piping connections. After pumping down refrigerant to inspect or relocate the outdoor unit, stop the compressor and remove the connected pipes.
  - Do not operate the compressor while a valve is open due to refrigerant leakage from a pipe or an unconnected or incorrectly connected pipe. Failure to do so may cause air to flow into the compressor and too high pressure to develop inside the refrigerant circuit, leading to an explosion or product malfunction.

Pump-down is an operation intended to collect all the system refrigerant in the outdoor unit. This operation must be carried out before disconnecting the refrigerant pipe to avoid refrigerant loss to the atmosphere.

- 1 Turn the system on in cooling with the fan operating at high velocity and then let the compressor run for more than 5 minutes. (Compressor will immediately start, provided 3 minutes have elapsed since the last stop.)
- 2 Release the valve caps on High and Low pressure sides.
- 3 Use an L-wrench to close the valve on the high pressure side.
- 4 After approximately 2 minutes, close the valve on the low pressure side.
- 5 Stop the mini-split's operation by pressing the  (Power) button on the indoor unit or remote control.
- 6 Disconnect the pipes.

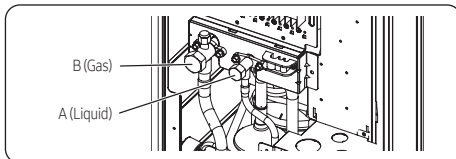

- The designs and shape are subject to change according to the model.

## Relocating the indoor and outdoor units

- 1 Pump down refrigerant. See Pumping down refrigerant on page 36.
- 2 Disconnect the power supply only after rendering the system powerless from the main power.
- 3 Disconnect the assembly cable from the indoor and outdoor units.
- 4 Remove the flare nuts connecting the indoor units and the pipes. At this time, cover the pipes of the indoor unit and the other pipes using a cap or vinyl plug to avoid foreign material entering.
- 5 Disconnect the pipes connected to the outdoor units. At this time, cover the valve of the outdoor units and the other pipes using a cap or vinyl plug to avoid foreign material entering.

### NOTE

- Make sure you do not bend the connection pipes in the middle and store them with the cables.
- 6 Move the indoor and outdoor units to a new location.
  - 7 Remove the mounting plate for the indoor unit and move it to a new location.

## Using the stop valve

### Opening the stop valve

- 1 Open the cap and turn the stop valve counterclockwise using a hexagonal wrench.
- 2 Turn it until the axis is stopped.

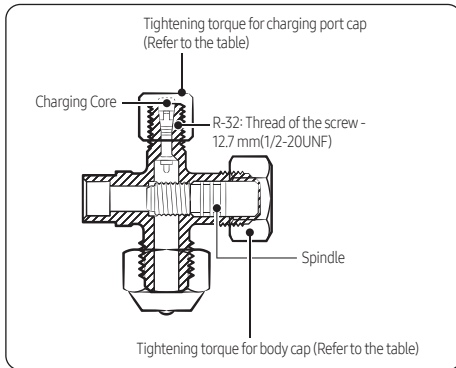

- 3 Tighten the cap securely.

Outer Diameter (mm)	Tightening torque	
	Body cap (N•m)	Charging port cap (N•m)
Ø 6.35	20 to 25	10 to 12
Ø 9.52	20 to 25	
Ø 12.70	25 to 30	
Ø 15.88	30 to 35	

- (1 N•m=10 kgf•cm)

### NOTE

- Do not apply excessive force to the stop valve always use special instruments. Otherwise, the stopping box can be damaged, and the back sheet can leak.
- If the watertight sheet leaks, turn the axis back by half, tighten the stopping box, and then check for leaks again. If there is no leakage, tighten the axis entirely.

### Closing the stop valve

- 1 Remove the cap.
- 2 Turn the stop valve clockwise by using a hexagonal wrench.
- 3 Tighten the axis until the valve reaches the sealing point.
- 4 Tighten the cap securely.

### CAUTION

- When you use the service port, always use a charging hose, too.
- Check the leakage of refrigerant gas after tightening the cap.
- Must use a spanner and wrench when you open/tighten the stop valve.

# Maintenance Procedures

---

## Performing the gas leak tests for repair

---

When repairing the refrigerant circuit, the following procedure must be followed to avoid flammability.

- 1 Remove the refrigerant.
- 2 Flush the system with nitrogen.
- 3 Repeat the previous step several times until no refrigerant is within the system.
- 4 Perform the repair work.
- 5 Conduct a pressure test.
- 6 Purge the refrigerant circuit with inert gas.
- 7 Perform vacuuming.
- 8 Charge with refrigerant.
- 9 Perform a leak test.
- 10 It is recommended to perform a second leak test within one month.



### CAUTION

- Compressed air or oxygen shall not be used.
- Flush the system with nitrogen, pressurize the refrigerant circuit until the working pressure is reached, ventilate to the atmosphere, and then pull down to a vacuum state.
- For the final nitrogen blowing charge, the system shall be ventilated down to atmospheric pressure.
- The procedure is vital in case of brazing on the piping.
- Make sure that the outlet of the vacuum pump is not close to any ignition sources and there is ventilation available.
- Do not apply any permanent inductive or capacitance loads to the circuit without ensuring that this will not exceed the permissible voltage and current permitted for the mini-split.

## Decommissioning

---

The following requirements must be fulfilled before and while taking the decommissioning procedure:

- Only qualified, licensed professionals shall perform refrigerant recovery and decommissioning. Before decommissioning, the worker shall become familiar with the product.
  - The entire refrigerant charge shall be recovered safely.
  - Before starting the process, oil and refrigerant samples shall be taken just in case analysis is required for reuse.
  - Before starting the process, a power supply must be available.
- 1 Be familiar with the equipment details.
  - 2 Isolate the system electrically.
  - 3 Before starting the process, make sure that:
    - Any mechanical equipment is available for handling refrigerant cylinders.
    - All PPE (personal protective equipment) is available for servicing.
    - The recovery process shall be supervised by a competent person.
    - The recovery equipment and cylinders comply with the standards. Only approved cylinders, with pressure relief valves, for the type of refrigerant shall be used.
  - 4 Pump down the refrigeration system, if possible.
  - 5 If vacuuming is not possible, make a manifold so that refrigerant can be easily removed from the parts of the system.
  - 6 Make sure that the cylinders are placed on the scales before recovery.
  - 7 Run the recovery system following the manufacturer's instructions.

- 
- 8 Do not overcharge the cylinders. (No more than 80 %)
  - 9 Keep the cylinder within the maximum working pressure, even temporarily.
  - 10 After charging, make sure that the cylinders and the equipment are promptly removed from the site and all isolation valves are closed.
  - 11 Recovered refrigerant shall not be mixed or reused. It shall be processed according to national, state, and local regulations.
  - 12 After decommissioning, the system shall be labeled stating that it has been decommissioned. The label shall be dated and signed.
  - 13 Ensure that there are labels on the equipment indicating the equipment contains flammable refrigerant.

# Appendix

## Troubleshooting

- The table below list the self-diagnostic routines. For some errors, you must contact an authorized service center.
- If an error occurs during the operation, it is displayed on the outdoor unit PCB MAIN-OUT.

PCB MAIN - OUT

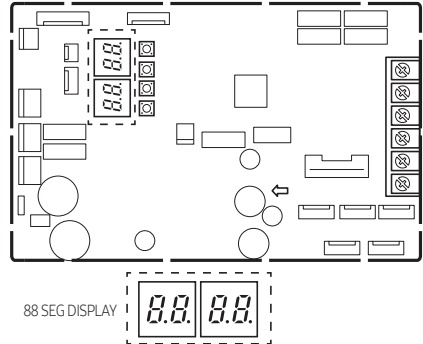

Error Code	Explanation	Remark
E108	Error due to repeated address setting(when 2 or more devices has the same address within the network)	
E116	R-32 detection sensor 'short' or 'open' or 'abnormal signal' error	
E118	Error due to Indoor fan PCB over heat	
E190	Pipe check error	
E199	Pipe check operation has not been completed	
E201	Communication error between indoor and outdoor unit (installation number setting error, repeated indoor unit address, indoor unit comm)	
E202	Communication error between indoor and outdoor unit (communication error on all indoor units, outdoor unit communication cable error)	
E203	Communication error between inverter pba and main pba	
E221	Error on ambient temperature sensor (short or open)	
E237	Error on condensor temperature sensor (short or open)	
E251	Error on discharge temperature sensor (short or open)	
E320	Error on compressor o/p temperature sensor (short or open)	
E330	Error on pipe in-a temperature sensor (short or open)	
E331	Error on pipe in-b temperature sensor (short or open)	
E332	Error on pipe in-c temperature sensor (short or open)	



Error Code	Explanation	Remark
E333	Error on pipe in-d temperature sensor (short or open)	
E334	Error on pipe in-e temperature sensor (short or open)	
E335	Error on pipe out-a temperature sensor (short or open)	
E336	Error on pipe out-b temperature sensor (short or open)	
E337	Error on pipe out-c temperature sensor (short or open)	
E338	Error on pipe out-d temperature sensor (short or open)	
E339	Error on pipe out-e temperature sensor (short or open)	
E381	Error due to Inverter PBA over heat	
E401	Outdoor unit freezing-safety control (compressor stop)	
E404	Outdoor unit overload-safety control (compressor stop)	
E416	Compressor operation stop due to discharge temperature protection control	
E422	High pressure blockage control	
E440	Heating mode restriction due to high air temperature	
E441	Cooling mode restriction due to low air temperature	
E458	Fan motor error	
E461	Operation failure of compressor	
E462	Compressor operation stop due to full load current control	
E463	Compressor operation stop due to olp temperature control	
E464	Error due to over-current of compressor	
E465	Voltage-limit error of compressor	
E466	Error due to low/over voltage of dc link in inverter pba	
E467	Abnormal rpm in compressor or wire for compressor has not been connected	
E468	Error due to output current sensor of inverter pba(short/open)	
E469	Error due to dc link voltage sensor of inverter pba(short/open)	
E470	Outdoor unit eeprom read/write error	
E471	Outdoor unit eeprom read/write error(otp)	
E474	Error on ipm/pfcm temperature sensor of inverter pba(short or open)	

# Appendix

---

Error Code	Explanation	Remark
E475	Fan2 motor error	
E483	Overvoltage of h/w detect dc link	
E484	Pfc overload(over current) error	
E485	Error due to input current sensor of inverter pba(short/open)	
E488	Incoming voltage sensor error	
E500	Ipm/pfcm overheat error	
E507	Error due to high pressure switch open or compressor down by high pressure	
E554	The refrigerant leaks completely from the outdoor unit	
E563	Error due to indoor unit software version combination(incompatible indoor unit software on a system	
E590	Inverter eeprom checksum error	
E695	R-32 detection sensor life unpredictable error	
E697	R-32 detection sensor 2nd detecting error	
E698	R-32 detection sensor failure error	
E699	R-32 detection sensor replacement notification error	
E700	R-32 detection sensor life-expiration error	

# Memo

---

