

THIS MANUAL MUST BE LEFT WITH THE BUILDING OWNER FOR FUTURE REFERENCE

⚠ WARNING

Horizontal application requires adjustment of the Refrigerant Detection sensor, drain pan and drip pan. Refer to instruction sections Horizontal Applications and Installing Condensate Drain.

⚠ WARNING

Improper installation, adjustment, alteration, service or maintenance can cause property damage, personal injury or loss of life. Installation and service must be performed by a licensed professional HVAC installer or equivalent, service agency, or the gas supplier.

⚠ CAUTION

As with any mechanical equipment, contact with sharp sheet metal edges can result in personal injury. Take care while handling this equipment and wear gloves and protective clothing.

⚠ IMPORTANT

The Clean Air Act of 1990 bans the intentional venting of refrigerant (CFCs, HCFCs and HFCs) as of July 1, 1992. Approved methods of recovery, recycling or reclaiming must be followed. Fines and/or incarceration may be levied for noncompliance.

⚠ WARNING

To prevent serious injury or death:

1. Lock-out/tag-out before performing maintenance.
2. If system power is required (e.g., smoke detector maintenance), disable power to blower, remove fan belt where applicable, and ensure all controllers and thermostats are set to the "OFF" position before performing maintenance.
3. Always keep hands, hair, clothing, jewelry, tools, etc. away from moving parts.

NOTE – The ELKA is a PARTIAL UNIT AIR HANDLER, complying with PARTIAL UNIT requirements in this standard, and must only be connected to other units that have been confirmed as complying to corresponding PARTIAL UNIT requirements of this Standard, UL 60335-2-40/CSA C22.2 No. 60335-2-40, or UL 1995/CSA C22.2 No 236.

INSTALLATION INSTRUCTIONS

ELKA Series – 6 - 20 Tons

AIR HANDLERS
508670-01
1/2025

Table of Contents

Model Number Identification	6
EL072KA and EL090KA Unit Dimensions – Inches (mm) .	7
EL120KA and EL150KA Dimensions – Inches (mm).....	8
EL180KA and EL240KA Dimensions – Inches (mm).....	9
Unit Parts Arrangement	10
Unit Control Box Components Arrangement	11
Typical Installation Support Method	11
Refrigerant Piping Connections	13
Installation	15
Horizontal Applications	17
Upflow Applications	17
Sensor Installation / Relocation	18
Installing Condensate Drain	21
Freezestat Connections	22
Filter Rack Installation	23
Duct Connections	25
Sealing the Unit	26
Wiring	26
Blower Motor Belt Tensioning Adjustment	29
Air Volume Adjustment	30
Blower Data	30
Supply Air Inverter Startup.....	31
Thermostat Compatibility.....	31
Refrigerant Leak Detection System.....	32
Normal System Operation	33
Blower Drive Components	37
Blower Performance	38
Repairing or Replacing Cabinet Insulation	44
Preventive Maintenance / Repair	44
Sensor Maintenance	45
Decommissioning	45
Start-Up and Performance Checklist.....	46

General

This ELKA indoor air handler is designed for use with R-454B refrigerant only and optional field-installed electric heat. The air handler units are for indoor installation only and are designed for upflow or horizontal applications. This unit must be installed with an approved outdoor air conditioner and line set as outlined in the ELKA Engineering Handbook. These instructions are intended as a general guide and do not supersede local codes in anyway. Consult local authorities having jurisdiction before installation.

NOTE – Appliance intended only for indoor use (excluding laundry rooms).

NOTE – For installation only in locations NOT accessible to the general public, such as under a drop ceiling or within a mechanical closet.



WARNING

- The appliance shall be stored in a room without continuously operating ignition sources (for example: open flames, an operating gas appliance, or an operating electric heater).
- Do not pierce or burn.
- Be aware that refrigerants may not contain an odor.

CAUTION

Servicing shall be performed only as recommended by the manufacturer.

WARNING

Ducts connected to an appliance shall not contain a potential ignition source

WARNING

Every working procedure that affects safety means shall only be carried out by competent persons. This appliance is not to be used by persons (including children) with reduced physical, sensory or mental capabilities, or lack of experience and knowledge, unless they have been given supervision or instruction concerning use of the appliance by a person responsible for their safety. Children should be supervised to ensure they do not play with the appliance.

IMPORTANT

Ensure that the area is in the open or that it is adequately ventilated before breaking into the system or conducting any hot work. A degree of ventilation shall continue during the period that the work is carried out. The ventilation should safely disperse any released refrigerant and preferably expel it externally into the atmosphere.

IMPORTANT

Verify cabling will not be subject to wear, corrosion, excessive pressure, vibration, sharp edges or any other adverse environmental effects. The check shall also take into account the effects of aging or continual vibration from sources such as compressors or fans.

IMPORTANT

Pipe work, including piping material, pipe routing, and installation shall include protection from physical damage in operation and service, and be in compliance with national and local codes and standards, such as ASHRAE 15, ASHRAE 15.2, IAPMO Uniform Mechanical Code, ICC International Mechanical Code, or CSA B52. All field joints shall be accessible for inspection prior to being covered or enclosed.

CAUTION

Under no circumstances shall potential sources of ignition be used in the searching for or detection of refrigerant leaks. A halide torch (or any other detector using a naked flame) shall not be used.

The following leak detection methods are deemed acceptable for all refrigerant systems.

Electronic leak detectors may be used to detect refrigerant leaks but, in the case of flammable refrigerants, the sensitivity may not be adequate, or may need recalibration. (Detection equipment shall be calibrated in a refrigerant-free area.) Ensure that the detector is not a potential source of ignition and is suitable for the refrigerant used. Leak detection equipment shall be set at a percentage of the LFL of the refrigerant and shall be calibrated to the refrigerant employed, and the appropriate percentage of gas (25 % maximum) is confirmed. Leak detection fluids are also suitable for use with most refrigerants but the use of detergents containing chlorine shall be avoided as the chlorine may react with the refrigerant and corrode the copper pipe-work. If a leak is suspected, all naked flames shall be removed/extinguished. If a leakage of refrigerant is found which requires brazing, all of the refrigerant shall be recovered from the system, or isolated (by means of shut off valves) in a part of the system remote from the leak.

CAUTION

Some soaps used for leak detection are corrosive to certain metals. Carefully rinse piping thoroughly after leak test has been completed. Do not use matches, candles, flame or other sources of ignition to check for gas leaks.

WARNING

PARTIAL UNITS shall only be connected to an appliance suitable for the same refrigerant.

IMPORTANT

When breaking into the refrigerant circuit to make repairs – or for any other purpose – conventional procedures shall be used. However, for flammable refrigerants it is important that best practice be followed and, since flammability is a consideration, procedures such as safely remove refrigerant following local and national regulations, purging the circuit with inert gas, evacuating (optional for A2L), purging with inert gas (optional for A2L), or opening the circuit by cutting or brazing be adhered to. The refrigerant charge shall be recovered into the correct recovery cylinders if venting is not allowed by local and national codes. For appliances containing flammable refrigerants, the system shall be purged with oxygen-free nitrogen to render the appliance safe for flammable refrigerants.

This process might need to be repeated several times. Compressed air or oxygen shall not be used for purging refrigerant systems. For appliances containing flammable refrigerants, refrigerants purging shall be achieved by breaking the vacuum in the system with oxygen-free nitrogen and continuing to fill until the working pressure is achieved, then venting to atmosphere, and finally pulling down to a vacuum (optional for A2L). This process shall be repeated until no refrigerant is within the system (optional for A2L). When the final oxygen-free nitrogen charge is used, the system shall be vented down to atmospheric pressure to enable work to take place. Ensure that the outlet for the vacuum pump is not close to any potential ignition sources and that ventilation is available.

IMPORTANT

In addition to conventional charging procedures, the following requirements shall be followed.

- Ensure that contamination of different refrigerants does not occur when using charging equipment. Hoses or lines shall be as short as possible to minimize the amount of refrigerant contained in them.
- Cylinders shall be kept in an appropriate position according to the instructions.
- Ensure that the REFRIGERATING SYSTEM is earthed prior to charging the system with refrigerant.
- Label the system when charging is complete (if not already).
- Extreme care shall be taken not to overfill the REFRIGERATING SYSTEM.

Prior to recharging the system, it shall be pressure-tested with the appropriate purging gas. The system shall be leak tested on completion of charging, but prior to commissioning. A follow up leak test shall be carried out prior to leaving the site.

IMPORTANT

When removing refrigerant from a system, either for servicing or decommissioning, it is recommended good practice that all refrigerants are removed safely.

When transferring refrigerant into cylinders, ensure that only appropriate refrigerant recovery cylinders are employed. Ensure that the correct number of cylinders for holding the total system charge is available. All cylinders to be used are designated for the recovered refrigerant and labelled for that refrigerant (i. e. special cylinders for the recovery of refrigerant). Cylinders shall be complete with pressure-relief valve and associated shut-off valves in good working order. Empty recovery cylinders are evacuated and, if possible, cooled before recovery occurs.

The recovery equipment shall be in good working order with a set of instructions concerning the equipment that is at hand and shall be suitable for the recovery of all appropriate refrigerants including, when applicable, flammable refrigerants. In addition, a set of calibrated weighing scales shall be available and in good working order. Hoses shall be complete with leak-free disconnect couplings and in good condition. Before using the recovery machine, check that it is in satisfactory working order, has been properly maintained and that any associated electrical components are sealed to prevent ignition in the event of a refrigerant release. Consult manufacturer if in doubt.

The recovered refrigerant shall be returned to the refrigerant supplier in the correct recovery cylinder, and the relevant waste transfer note arranged. Do not mix refrigerants in recovery units and especially not in cylinders.

If compressors or compressor oils are to be removed, ensure that they have been evacuated to an acceptable level to make certain that flammable refrigerant does not remain within the lubricant. The evacuation process shall be carried out prior to returning the compressor to the suppliers. Only electric heating to the compressor body shall be employed to accelerate this process. When oil is drained from a system, it shall be carried out safely.

IMPORTANT

After completion of field piping for split systems, the field pipework shall be pressure tested with an inert gas and then vacuum tested prior to refrigerant charging, according to the following requirements;

- Field-made refrigerant joints indoors shall be tightness tested. The test method shall have a sensitivity of .2 oz. (5 grams) per year of refrigerant or better, under pressure. No leak shall be detected.

CAUTION

Leak Detection System installed. Unit must be powered except for service.

WARNING

Maximum Altitude of application is 2000m above sea level.

WARNING

- Do not use means to accelerate the defrosting process or to clean, other than those recommended by the manufacturer.
- The appliance shall be stored in a room without continuously operating ignition sources (for example: open flames, an operating gas appliance, or an operating electric heater).
- Do not pierce or burn.
- Be aware that refrigerants may not contain an odor.

WARNING

For appliances using A2L refrigerants connected via an air duct system to one or more rooms, only auxiliary devices approved by the appliance manufacturer or declared suitable with the refrigerant shall be installed in connecting ductwork.

WARNING

Auxiliary devices which may be a potential ignition source shall not be installed in the duct work. Examples of such potential ignition sources are hot surfaces with a temperature exceeding 700°C and electric switching devices.

WARNING

For duct connected appliances, false ceilings or drop ceilings may be used as a return air plenum if a REFRIGERANT DETECTION SYSTEM is provided in the appliance and any external connections are also provided with a sensor immediately below the return air plenum duct joint.

CAUTION

Any service personnel installing, decommissioning, or performing maintenance on the unit must be properly trained with A2L refrigerants

WARNING

If this appliance is conditioning a space with an area smaller than T_{Amin} or stored in a space with an area smaller than T_{Amin} as defined by this instruction, then that space must be without continuously operating open flames (e.g. an operating gas appliance) or other potential ignition sources (e.g. an operating electric heater or similar hot surface). A flame-producing device may be installed in the same space if the device is provided with an effective flame arrest system.

APPLICATION CONSIDERATIONS

R-454B is a A2L refrigerant. The system installation must meet the following parameters based upon total refrigerant charge (line set included).

When a system has a single compressor, the total refrigerant charge (lb/kg) is the sum of the factory charge plus the field added charge. For multiple compressor systems, use the compressor circuit with the largest total refrigerant charge (lb/kg) calculated the same as single compressor.

T_{Amin} (Total minimum conditioned area) is the minimum allowable conditioned area based upon the total system charge at sea level. Values must be multiplied by altitude adjustment factor at installed altitude.

Q_{min} refers to minimum airflow requirements during refrigerant leak mitigation by the refrigerant detection system, based upon total system charge.

For applications where the final charge is greater than listed in the **T_{Amin} Table**, specific requirements in ANSI/ASHRAE Standard 15, Safety Standard for Refrigeration Systems, may be more stringent than those in UL 60335-2-40 standard. Refer to the ANSI/ASHRAE Standard 15, Safety Standard for Refrigeration Systems, to determine any additional requirements based on total system charge.

T_{Amin} Table

Charge (lb)	10.0	15.0	20.0	25.0	30.0
Charge (kg)	4.5	6.8	9.1	11.3	13.6
Minimum Conditioned Area (ft ²)	149.9	224.9	299.9	374.8	449.8
Minimum Conditioned Area (m ²)	13.9	20.9	27.9	34.8	41.8

NOTE – Multiply values in T_{Amin} table by the Altitude Adjustment Factors to correct T_{Amin} based on installed altitude.

Altitude Adjustment Factor

Altitude (m)	0	200	400	600	800	1000	1200	1400	1600	1800	2000
Altitude (ft)	0	660	1310	1970	2620	3280	3940	4590	5250	5910	6560
Adj. Factor	1	1	1	1	1.02	1.05	1.04	1.1	1.12	1.15	1.18

Q_{min} Table

Refrigerant Charge lb (kg)	CFM Required	Refrigerant Charge lb (kg)	CFM Required
5 (2.3)	135	18 (8.1)	487
6 (2.7)	162	19 (8.6)	514
7 (3.2)	189	20 (9.1)	541
8 (3.6)	216	21 (9.5)	568
9 (4.1)	244	22 (10)	595
10 (4.5)	271	23 (10.4)	622
11 (5)	298	24 (10.9)	649
12 (5.4)	325	25 (11.3)	676
13 (5.9)	352	26 (11.7)	704
14 (6.4)	379	27 (12.2)	731
15 (6.8)	406	28 (12.7)	758
16 (7.3)	433	29 (13.2)	785
17 (7.7)	460	30 (13.6)	812

NOTE – Q_{min} minimum airflow requirement for refrigerant leak mitigation.

Shipping and Packing List

Package contains the following:

- 1 – Assembled blower coil unit
- 1 – Filter rack (shipped inside unit)
- 8 – Supply and return air flanges (shipped inside unit) listed in table 2 on page 25

1 – Bag assembly that consists of the following:

- Installation instruction
- Six plastic grommets (various sizes) for line set knockouts

Check package contents for shipping damage; if found, immediately report damage to last carrier.

Model Number Identification

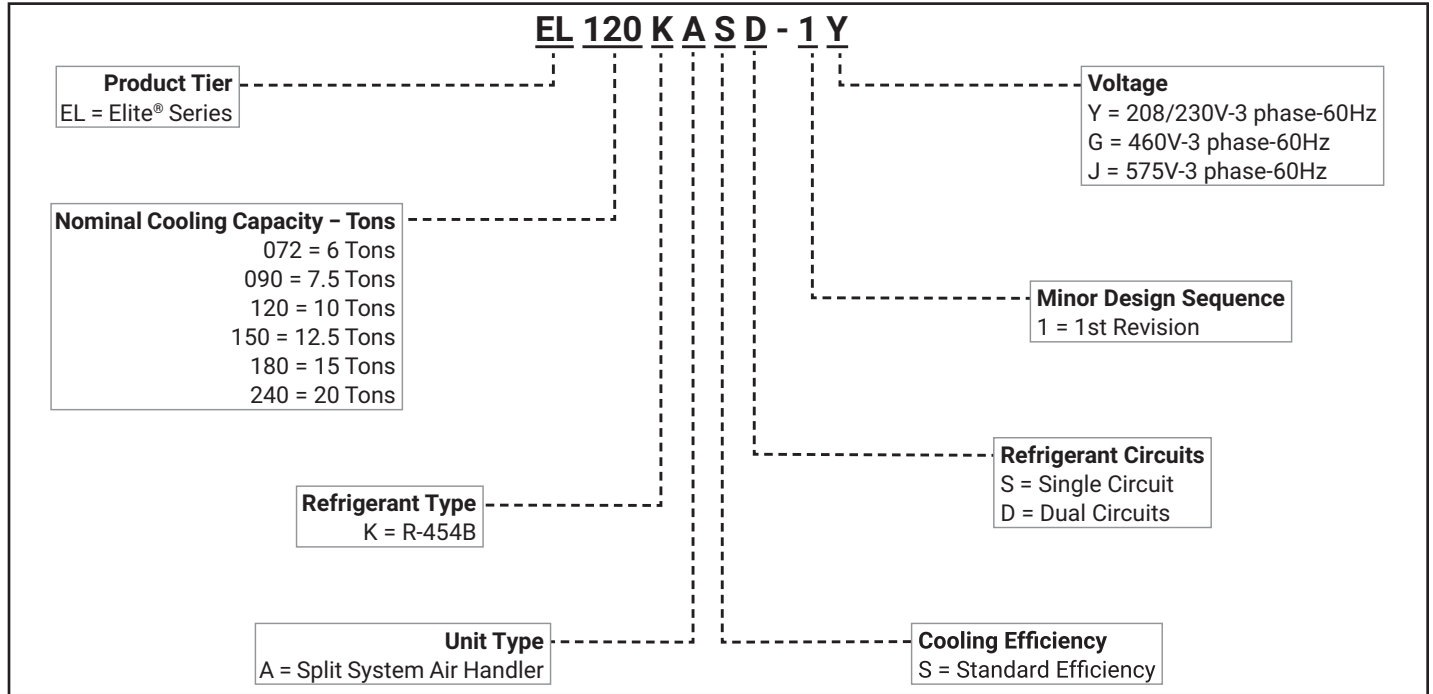

EL072KA and EL090KA Unit Dimensions – Inches (mm)

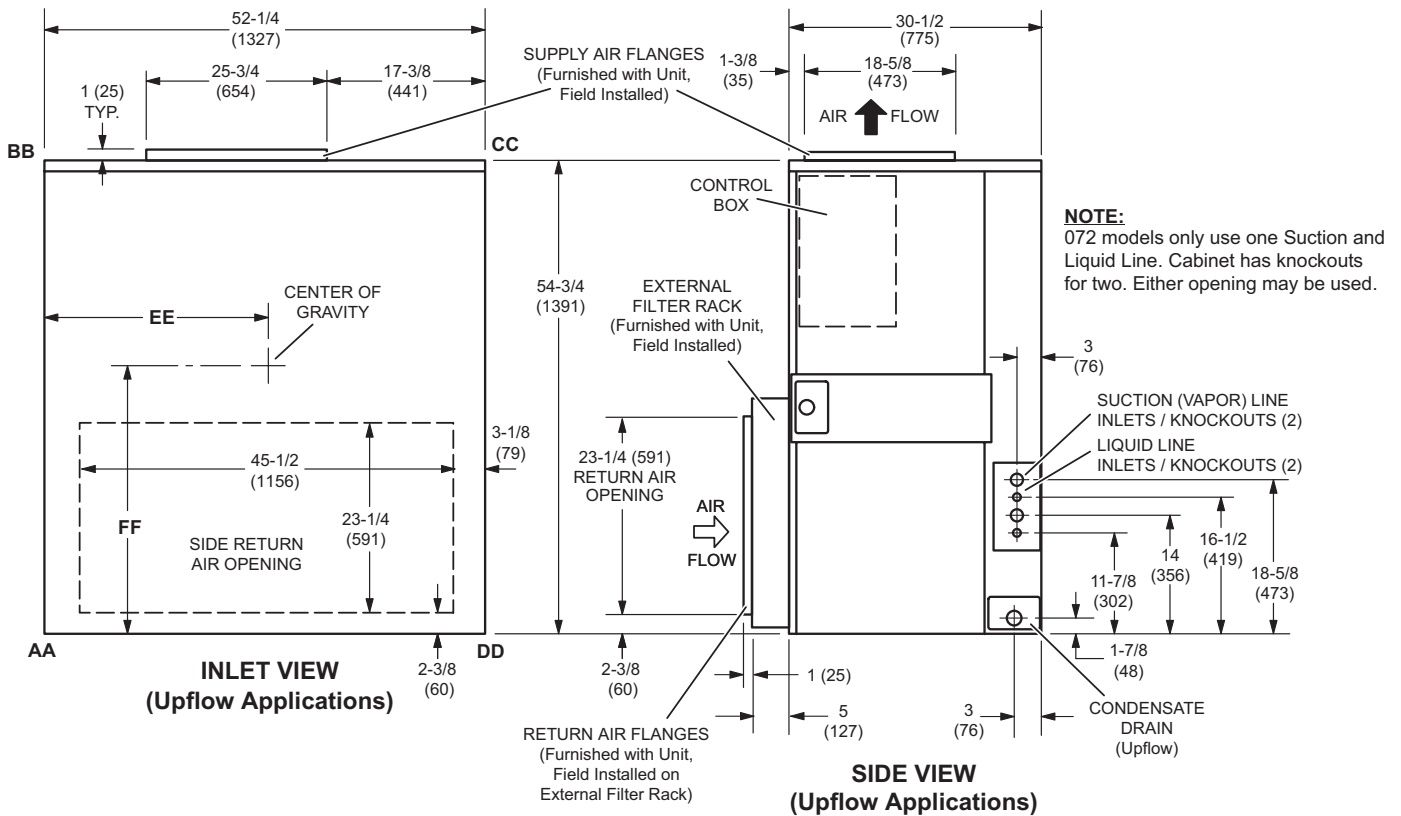
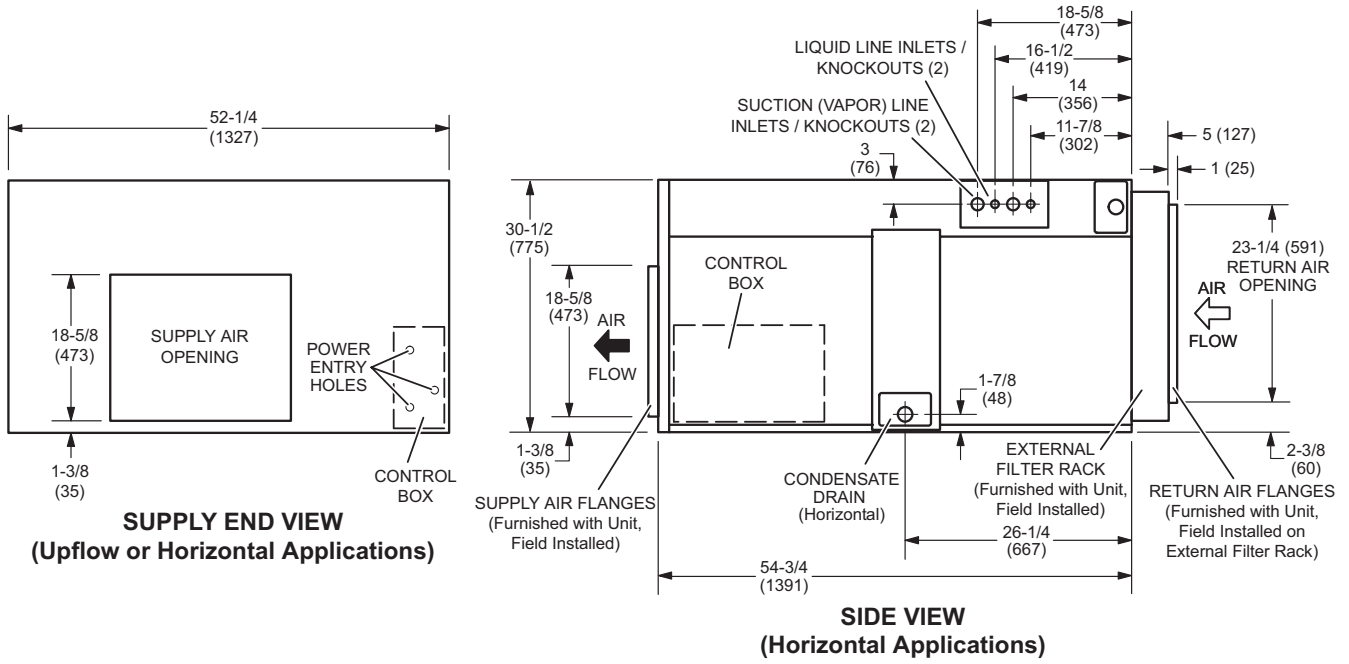

Model No.	CORNER WEIGHTS								CENTER OF GRAVITY			
	AA		BB		CC		DD		EE		FF	
	lbs.	kg	lbs	kg	lbs	kg	lbs	kg	lbs	kg	lbs	kg
EL072KA	102	46	102	46	102	46	102	46	26.1	640	27.4	671
EL090KA	108	49	108	49	108	49	108	49	26.1	640	27.4	671

EL120KA and EL150KA Dimensions – Inches (mm)

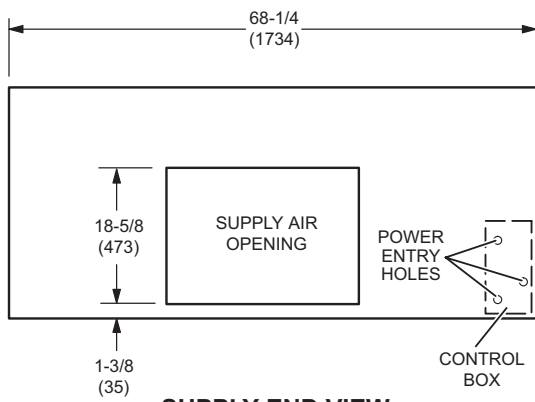

SUPPLY END VIEW
(Upflow or Horizontal Applications)

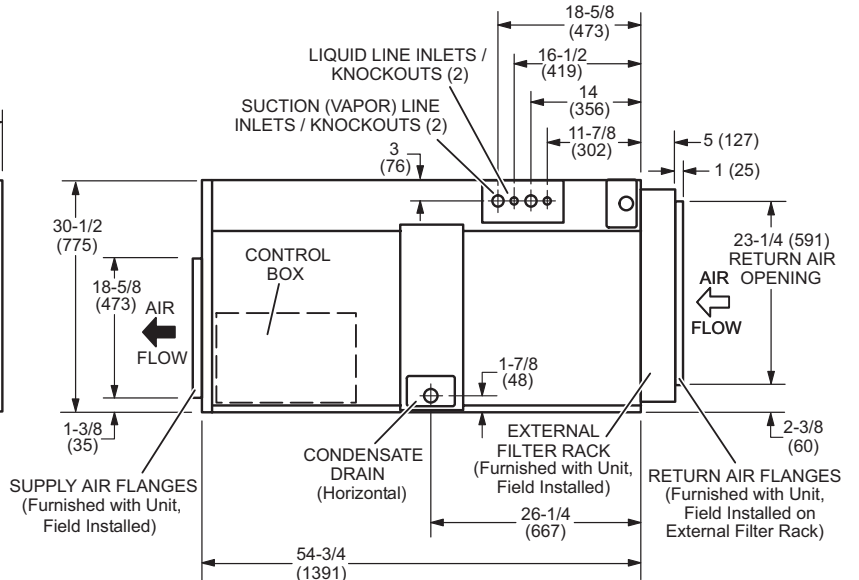

SIDE VIEW
(Horizontal Applications)

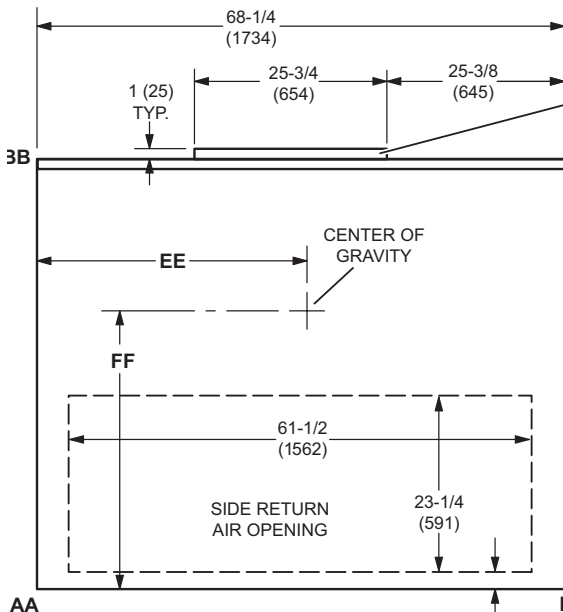

INLET VIEW
(Upflow Applications)

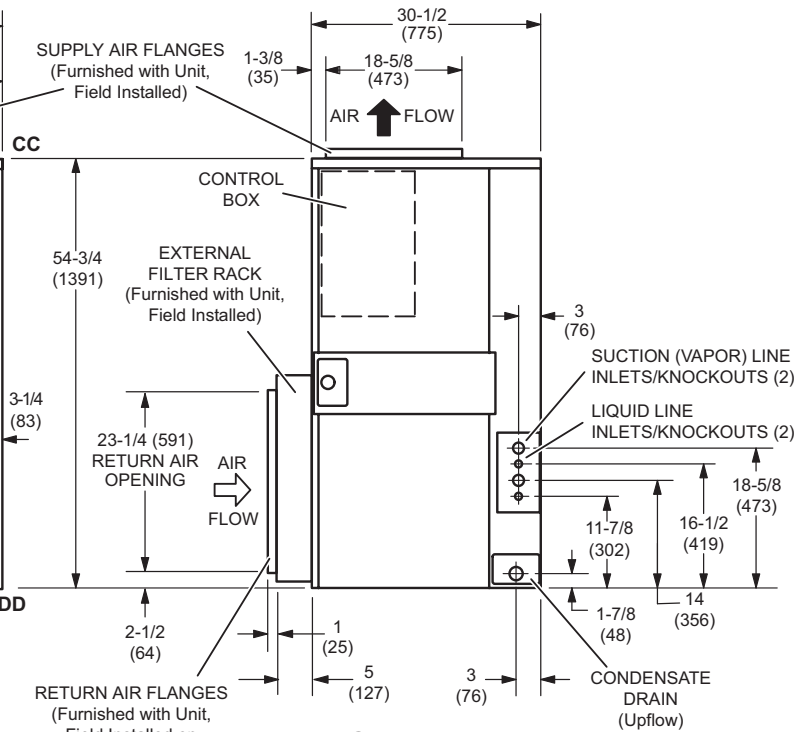

SIDE VIEW
(Upflow Applications)

CORNER WEIGHTS								CENTER OF GRAVITY				
Model No.	AA		BB		CC		DD		EE		FF	
	lbs.	kg	lbs	kg	lbs	kg	lbs	kg	lbs	kg	lbs	kg
EL120KA	126	57	121	55	121	55	126	57	34.1	836	25.9	635
EL150KA	130	59	125	57	125	57	130	59	34.1	836	25.9	635

EL180KA and EL240KA Dimensions – Inches (mm)

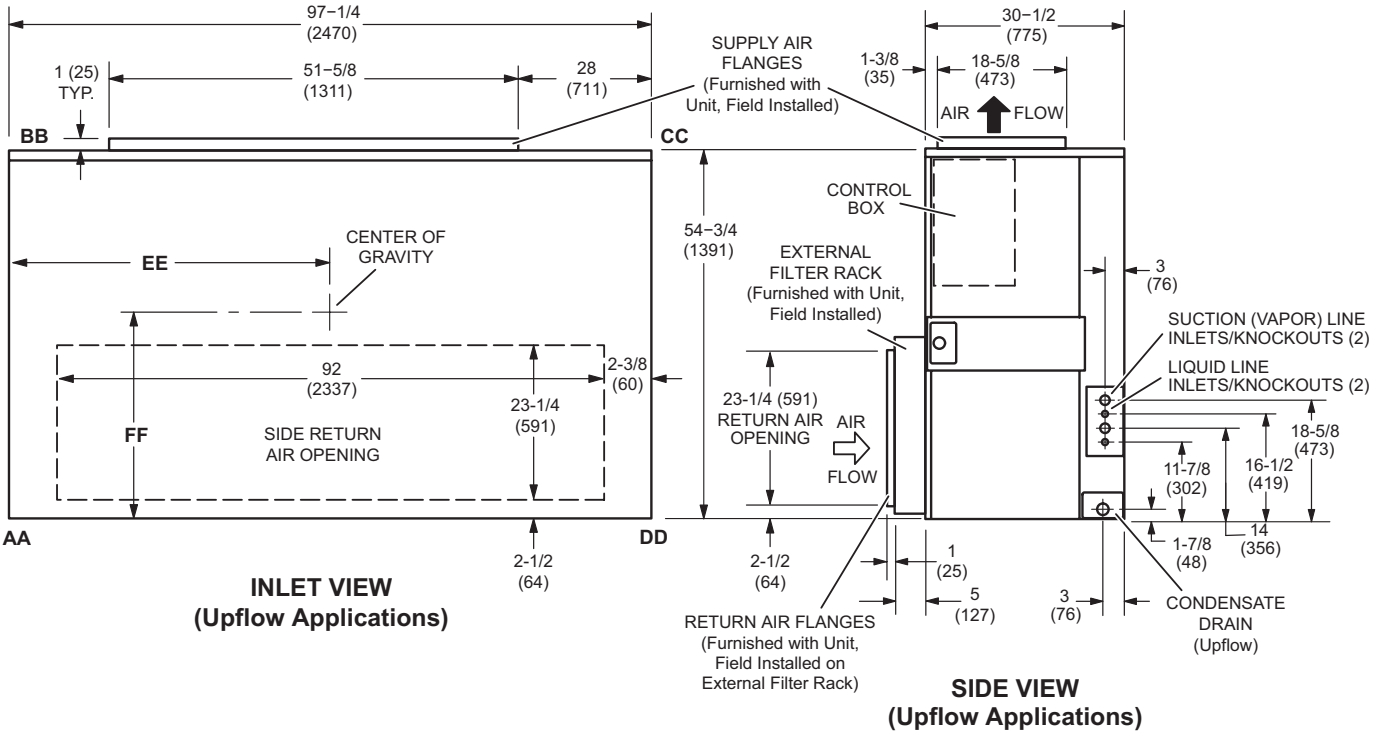
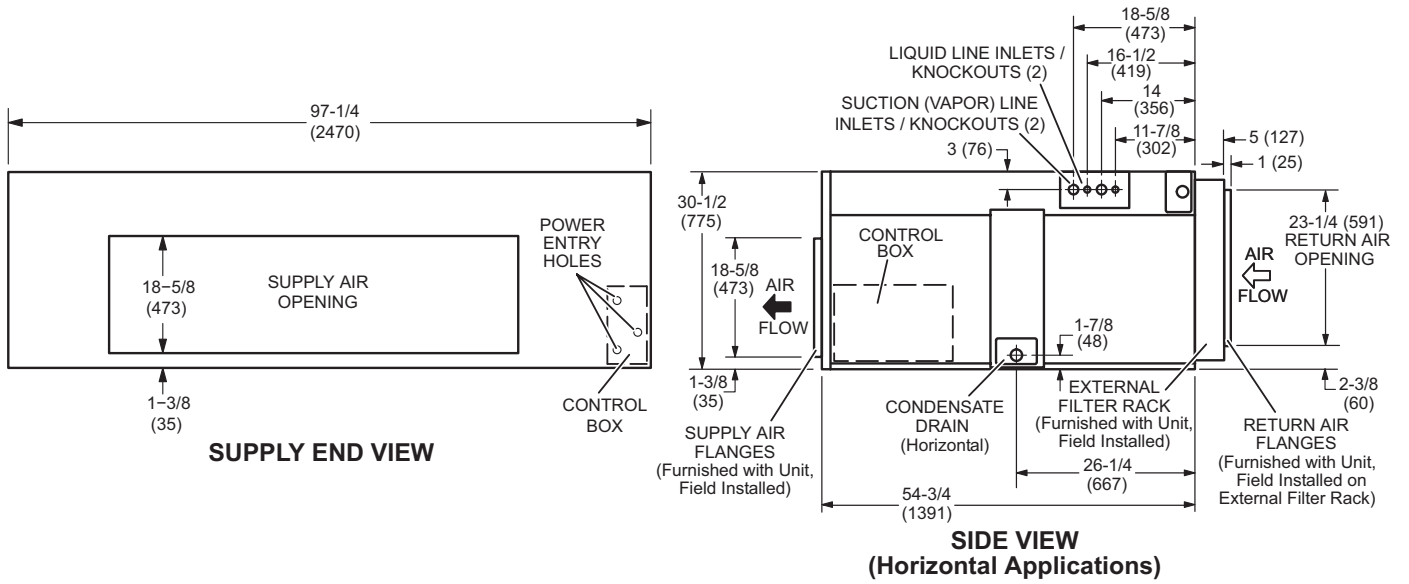

Model No.	CORNER WEIGHTS								CENTER OF GRAVITY			
	AA		BB		CC		DD		EE		FF	
	lbs.	kg	lbs.	kg	lbs.	kg	lbs.	kg	lbs.	kg	lbs.	kg
EL180KA	176	80	176	80	187	85	187	85	50.6	1240	27.4	671
EL240KA	189	86	189	86	211	96	211	96	52.1	1277	27.4	671

Unit Parts Arrangement

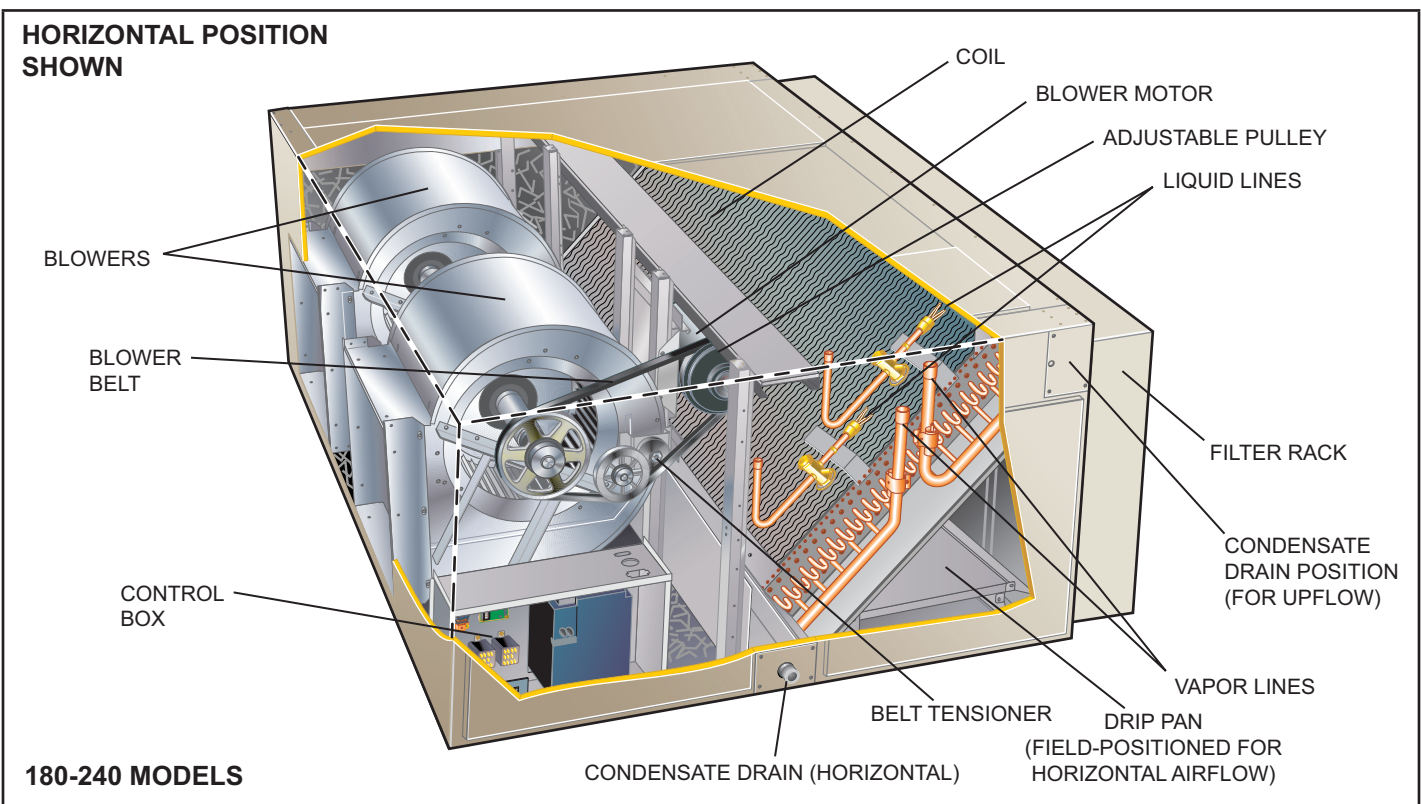
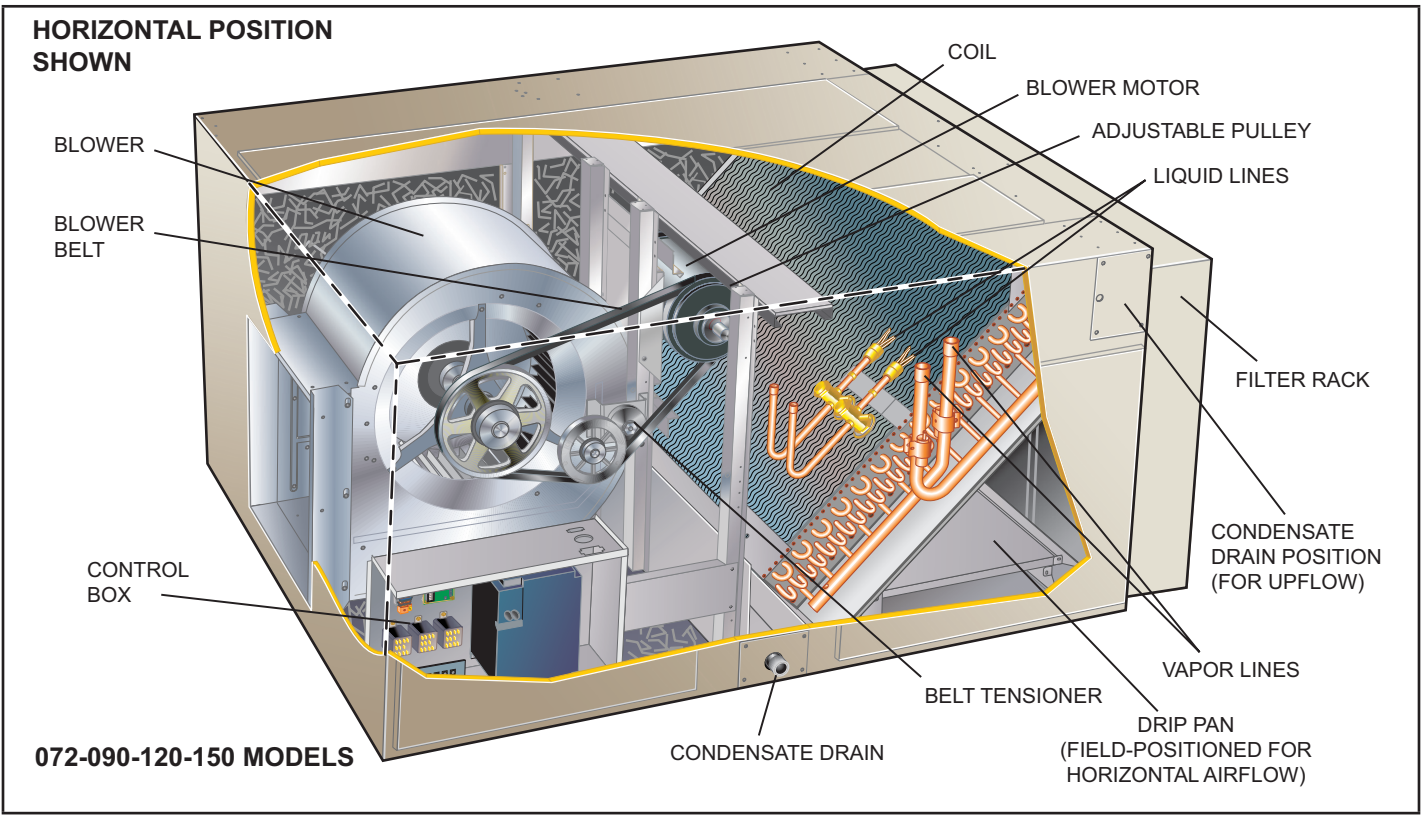

Unit Control Box Components Arrangement

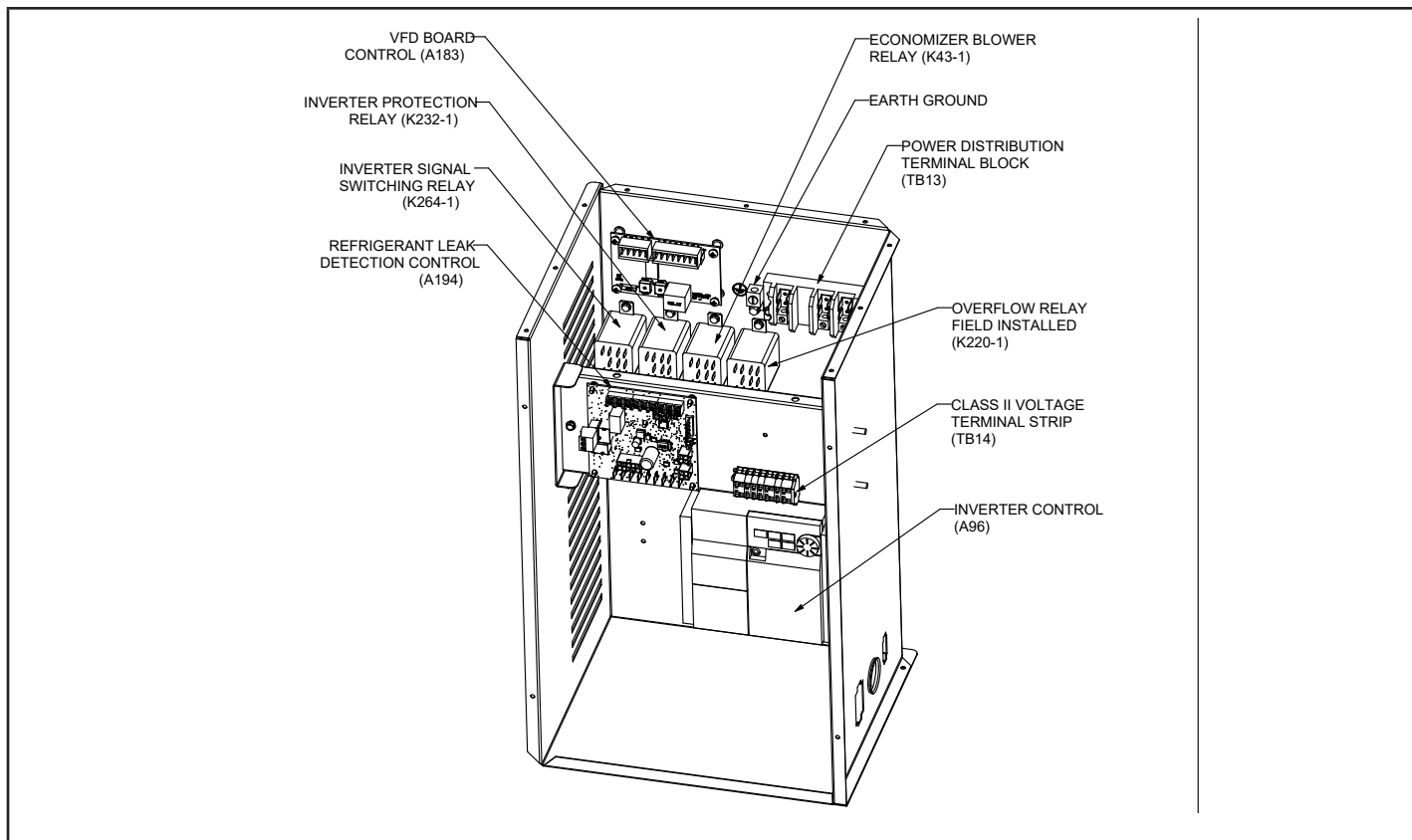

Typical Installation Support Method

TYPICAL SUPPORT METHOD FOR AIR HANDLER WITH HEAT SECTION IN HORIZONTAL POSITION

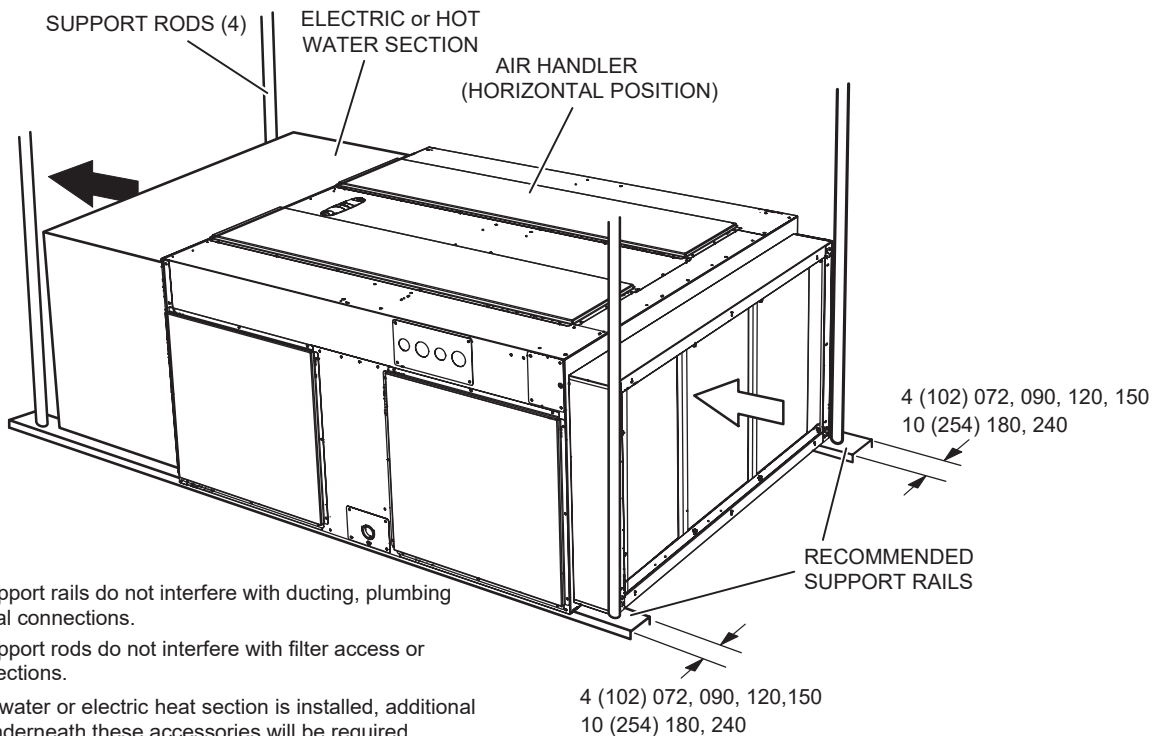

NOTES:

1. Ensure support rails do not interfere with ducting, plumbing or electrical connections.
2. Ensure support rods do not interfere with filter access or duct connections.
3. When hot water or electric heat section is installed, additional support underneath these accessories will be required.
4. Support rods and rails are field supplied.

INSTALLATION CLEARANCES

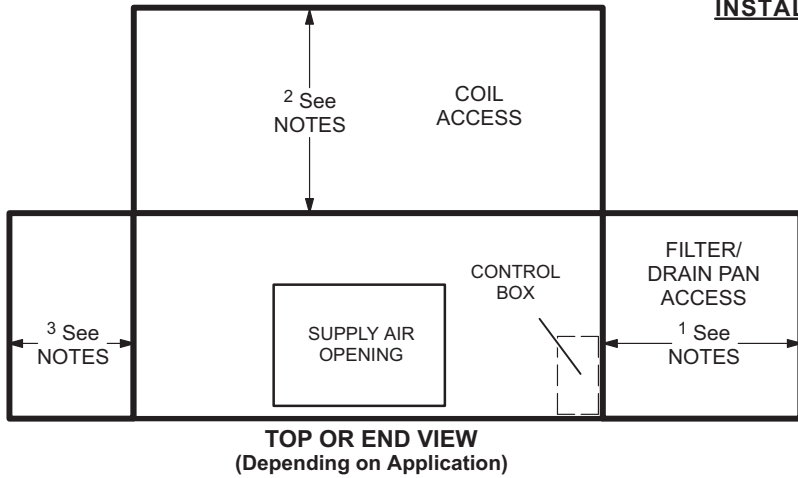

INSTALLATION CLEARANCES (WITH ELECTRIC HEAT)

- Cabinet – 0 in. (0 mm)
- To Plenum – 0 in. (0 mm)
- To Outlet Duct within 3 feet (914 mm) – 0 in. (0 mm)

RECOMMENDED SERVICE CLEARANCES

- 1 Filter Removal and Routine Maintenance:**
(Upflow/Horizontal)
36 in. (914 mm)
- 1 Service Clearance for Drain Pan Removal:**
(Upflow/Horizontal)
EL072KA, EL090KA – 57 in. (1448 mm)
EL120KA, EL150KA – 73 in. (1854 mm)
EL180KA, EL240KA – 102 in. (2590 mm)
- 2 Coil Cleaning and LDS Service (Upflow):**
All models – 36 in. (914 mm)
- 3 Alternate Coil Cleaning:**
Provide 36 in. (914 mm) on this side if top/rear access is obstructed
- 3 Alternate Drain/Refrigerant Line Location:**
Allow additional clearance if refrigerant or drain lines are routed from this side of cabinet
- 4 Freestanding Operation With Filter Rack But Without Return Air Duct**
All models - 24 in. (610 mm)

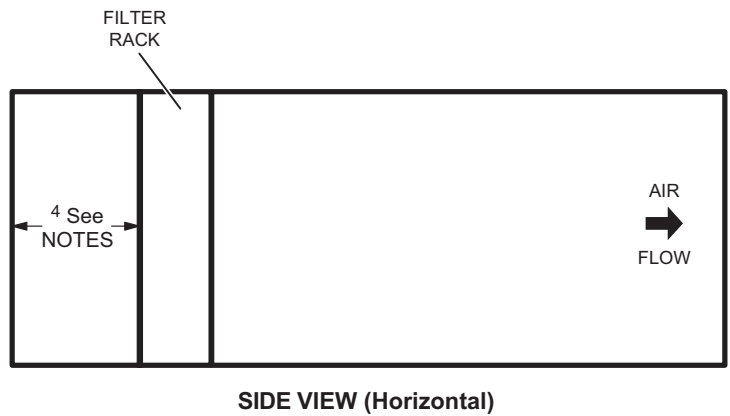
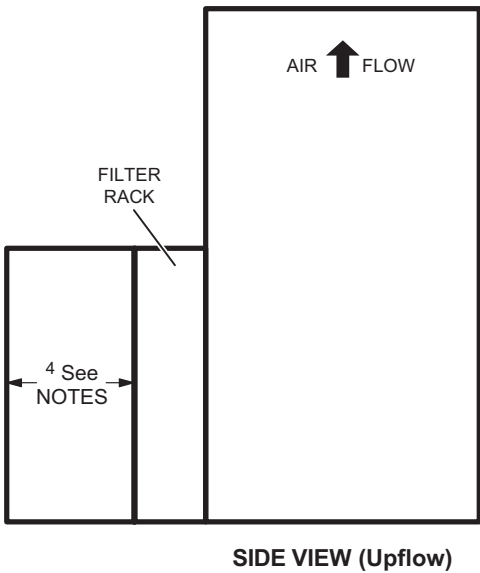

⚠ WARNING

To prevent personal injury, as well as damage to panels, unit or structure, observe the following: While installing or servicing this unit, carefully stow all removed panels so that the panels will not cause injury to personnel, objects or nearby structures. Also, take care to store panels where they will not be subject to damage (e.g., being bent or scratched). While handling or stowing the panels, consider any weather conditions (especially wind) that may cause panels to be blown around and damaged.

Requirements

These instructions are intended as a general guide and do not supersede local or national codes in any way. Consult authorities having jurisdiction before installation.

In addition to conforming to manufacturer's installation instructions and local municipal building codes, installation of ELKA air handler units (with or without optional electric heat), shall conform with the following National Fire Protection Association (NFPA) standards:

- NFPA No. 90A – Standard for Installation of Air Conditioning and Ventilation Systems
- NFPA No. 90B – Standard for Installation of Residence Type Warm Air Heating and Air Conditioning Systems

This unit is approved for installation clearance to combustible material as stated on the unit rating plate. Accessibility and service clearances must take precedence over combustible material clearances.

⚠ WARNING

Improper installation of the air handler can result in personal injury or death.

Do not allow external combustion products or other contaminants to enter the return air system or to be mixed with air that will be supplied to the living space. Use sheet metal screws and joint tape or duct mastic to seal return air system to air handler. In platform installations, the air handler should be sealed airtight to the return air plenum. A door must never be used as a portion of the return air duct system. The base must provide a stable support and an airtight seal to the air handler. Allow absolutely no sagging, cracks, gaps, etc.

For no reason should return and supply air duct systems ever be connected to or from other heating devices such as a fireplace or stove, etc. Fire, explosion, carbon monoxide poisoning, personal injury and/or property damage could result.

⚠ WARNING



Electric Shock Hazard.

Can cause injury or death.

Foil-faced insulation has conductive characteristics similar to metal. Be sure there are no electrical connections within 1/2" of the insulation. If the foil-faced insulation comes in contact with electrical voltage, the foil could provide a path for current to pass through to the outer metal cabinet. While the current produced may not be enough to trip existing electrical safety devices (e.g., fuses or circuit breakers), the current can be enough to cause an electrical shock hazard that could cause personal injury or death.

Refrigerant Piping Connections

ELKA series evaporator coils have a holding charge of nitrogen or dry air. If there is no pressure when the rubber plugs are removed, check the coil for leaks before installing. After installation, pull a vacuum on the coil and line set before releasing the outdoor unit charge into the system.

**TABLE 1. ELKA Refrigerant Connections
Size / Quantity**

Models	Liquid Line	Vapor / Suction Line
-072	5/8" (1)	7/8" (1)
-090, -120, -150	5/8" (2)	7/8" (2)
-180, -240	5/8" (2)	1-1/8" (2)

For single-compressor applications, pipe the upper and lower evaporator circuits together (does not apply to 072).

For dual-compressor applications, pipe the stage 1 system to the lower part of the evaporator and the stage 2 system to the upper part of the evaporator. Table 1 lists piping connection sizes at the evaporator coil. The line set between the air handler and outdoor unit should be sized per the Refrigerant Piping Design and Fabrication Guidelines (Corp. 9351-L9) or latest version.

- 1 - Route piping through either side of the unit.
- 2 - Remove the knockouts from the piping mullion. Install the rubber grommets into the piping holes.
- 3 - Remove the plugs from the vapor and liquid line stubs.
- 4 - Wrap a wet rag around each TXV before brazing to avoid overheating the valve.
- 5 - Remove protective coil cover between TXVs and evaporator coil as illustrated in Figure 1.

⚠ WARNING

Refrigerant can be harmful if it is inhaled. Refrigerant must be used and recovered responsibly.

Failure to follow this warning may result in personal injury or death.

WARNING



When using a high pressure gas such as nitrogen to pressurize a refrigeration or air conditioning system, use a regulator that can control the pressure down to 1 or 2 psig (6.9 to 13.8 kPa).

WARNING



Fire, Explosion and Personal Safety hazard. Failure to follow this warning could result in damage, personal injury or death.

Never use oxygen to pressurize or purge refrigeration lines. Oxygen, when exposed to a spark or open flame, can cause fire and/or an explosion, that could result in property damage, personal injury or death.

WARNING

Polyolester (POE) oils used with R-454B refrigerant absorb moisture very quickly. It is very important that the refrigerant system be kept closed as much as possible. DO NOT remove line set caps or service valve stub caps until you are ready to make connections.

WARNING

Every working procedure that affects safety means shall only be carried out by competent persons. This appliance is not to be used by persons (including children) with reduced physical, sensory or mental capabilities, or lack of experience and knowledge, unless they have been given supervision or instruction concerning use of the appliance by a person responsible for their safety. Examples of such working procedures are breaking into the refrigerating circuit, opening of sealed components, and opening of ventilated enclosures.

IMPORTANT

If this unit is being matched with an approved lineset that was previously charged with mineral oil, the line set must be flushed prior to installation.

Take care to empty all existing traps. Polyolester (POE) oils are used in Lennox units charged with R-454B refrigerant. Residual mineral oil can act as an insulator, preventing proper heat transfer. It can also clog the expansion device and reduce system performance and capacity. Failure to properly flush the system per this instruction and the detailed Installation and Service Procedures manual will void the warranty.

IMPORTANT

Braze-free fittings must conform with UL207 or ISO14903 (latest edition).

WARNING



Danger of fire. Bleeding the refrigerant charge from only the high side may result in pressurization of the low side shell and suction tubing. Application of a brazing torch to a pressurized system may result in ignition of the refrigerant and oil mixture. Check the high and low pressures before applying heat.

CAUTION

Brazing alloys and flux contain materials which are hazardous to your health.

Avoid breathing vapors or fumes from brazing operations. Perform operations only in well-ventilated areas.

Wear gloves and protective goggles or face shield to protect against burns.

Wash hands with soap and water after handling brazing alloys and flux.

IMPORTANT

Allow braze joint to cool. Apply additional water-saturated cloths to help cool brazed joint. Do not remove water-saturated cloths until piping has cooled. Temperatures above 250°F will damage valve seals.

WARNING



FIRE, PERSONAL INJURY OR PROPERTY DAMAGE may result if you do not wrap a water-saturated cloth around both liquid and suction line service valve bodies and copper tube stub while brazing the line set! The braze, when complete, must be quenched with water to absorb any residual heat.

Do not open service valves until refrigerant lines and indoor coil have been leak-tested and evacuated. Refer to Installation and Service Procedures manual found on LennoxPros.com

WARNING



Danger of explosion. Keep flammable materials and vapors, such as gasoline, away from air handler. Place air handler so that heating elements are at least 18 inches (46 cm) above the floor for a garage installation. Failure to follow these instructions can result in death, explosion, or fire.

IMPORTANT

Excessive condensation may occur if the unit is installed in a warm, humid place. When the unit is installed in an unconditioned space, apply sealant around electrical wires, refrigerant piping and condensate lines at the point where they enter the cabinet.

This will help prevent air leakage into, and condensation from forming inside of, the air handler, the control box, and on the electrical controls.

Installation

Every working procedure that affects safety means shall only be carried out by competent persons. This appliance is not to be used by persons (including children) with reduced physical, sensory or mental capabilities, or lack of experience and knowledge, unless they have been given supervision or instruction concerning use of the appliance by a person responsible for their safety. Examples of such working procedures are breaking into the refrigerating circuit, opening of sealed components, and opening of ventilated enclosures.

- Work shall be undertaken under a controlled procedure so as to minimize the risk of a flammable gas or vapor being present while the work is being performed.
- The area shall be checked with an appropriate refrigerant detector prior to and during work, to ensure the technician is aware of potentially toxic or flammable atmospheres. Ensure that the leak detection equipment being used is suitable for use with all applicable refrigerants, i. e. non-sparking, adequately sealed or intrinsically safe.
- If any hot work is to be conducted on the refrigerating equipment or any associated parts, the appropriate fire extinguishing equipment shall be available to hand. Have a dry powder or CO² fire extinguisher adjacent to the charging area.
- No person carrying out work in relation to a refrigerating system which involves exposing any pipe work shall use any sources of ignition in such a manner that it may lead to the risk of fire or explosion. All possible ignition sources, including cigarette smoking, should be kept sufficiently far away from the site of installation, repairing, removing and disposal, during which refrigerant can possibly be released to the surrounding space. Prior to work taking place, the area around the equipment is to be surveyed to make sure that there are no flammable hazards or ignition risks. "No Smoking" signs shall be displayed.
- Ensure that the area is in the open or that it is adequately ventilated before breaking into the system or conducting any hot work. A degree of ventilation shall continue during the period that the work is carried out. Ventilation should disperse any released refrigerant. When possible, expel refrigerant directly into the atmosphere.

- Pipe-work including piping material, pipe routing, and installation shall include protection from physical damage in operation and service, and be in compliance with national and local codes and standards
- All field joints shall be accessible for inspection prior to being covered or enclosed
- Where electrical components are being changed, they shall be fit for the purpose and to the correct specification. At all times the manufacturer's maintenance and service guidelines shall be followed. If in doubt, consult the manufacturer's technical department for assistance. The following checks shall be applied to installations using FLAMMABLE REFRIGERANTS as applicable:

1. The actual refrigerant charge is in accordance with the room size within which the refrigerant containing parts are installed.
 2. The ventilation machinery and outlets are operating adequately and are not obstructed.
 3. If an indirect refrigerating circuit is being used, the secondary circuit shall be checked for the presence of refrigerant.
 4. Markings on the equipment should be visible and legible. Markings and signs that are illegible shall be corrected.
 5. Refrigerating pipe or components are installed in a position where they are unlikely to be exposed to any substance which may corrode refrigerant containing components, unless the components are constructed of materials which are inherently resistant to being corroded or are suitably protected against being so corroded.
- For systems containing refrigerant, all repair and maintenance to electrical components shall include initial safety checks and component inspection procedures such as that capacitors are discharged in a safe manner to avoid possibility of sparking, that no live electrical components and wiring are exposed while charging, recovering, or purging the system, and that there is continuity of earth bonding. If a fault exists that could compromise safety, then no electrical supply shall be connected to the circuit until it is satisfactorily dealt with. If the fault cannot be corrected immediately but it is necessary to continue operation, an adequate temporary solution shall be used that is reported to the owner of the equipment, so all parties are advised.

NOTE – Sealed electrical components shall be replaced, not repaired.

NOTE – Intrinsically safe components must be replaced, not repaired.

NOTE – All maintenance staff and others working in the local area shall be instructed on the nature of work being carried out with work in confined spaces being avoided.

- Under no circumstances shall potential sources of ignition be used in the searching for or detection of refrigerant leaks. A halide torch (or any other detector using a naked flame) shall not be used. The following leak detection methods are deemed acceptable for all refrigerant systems. Electronic leak detectors may be used to detect refrigerant leaks but, in the case of flammable refrigerants, the sensitivity may not be adequate, or may need re-calibration. (Detection equipment shall be calibrated in a refrigerant-free area.) Ensure that the detector is not a potential source of ignition and is suitable for the refrigerant used. Leak detection equipment shall be set at a percentage of the LFL of the refrigerant and shall be calibrated to the refrigerant employed, and that 12.5 % refrigerant is confirmed. Leak detection fluids are also suitable for use with most refrigerants but the use of detergents containing chlorine shall be avoided as the chlorine may react with the refrigerant and corrode the copper pipe-work. If a leak is suspected, all naked flames shall be removed/ extinguished. If a leakage of refrigerant is found which requires brazing, all of the refrigerant shall be recovered from the system, or isolated (by means of shut off valves) in a part of the system remote from the leak.
- When breaking into the refrigerant circuit to make repairs – or for any other purpose – conventional procedures shall be used. However, for flammable refrigerants it is important that best practice be followed and, since flammability is a consideration, procedures such as safely remove refrigerant following local and national regulations, purging the circuit with inert gas, evacuating (optional for A2L), purging with inert gas (optional for A2L), or opening the

circuit by cutting or brazing be adhered to. The refrigerant charge shall be recovered into the correct recovery cylinders if venting is not allowed by local and national codes. For appliances containing flammable refrigerants, the system shall be purged with oxygen-free nitrogen to render the appliance safe for flammable refrigerants. This process might need to be repeated several times. Compressed air or oxygen shall not be used for purging refrigerant systems. For appliances containing flammable refrigerants, refrigerants purging shall be achieved by breaking the vacuum in the system with oxygen-free nitrogen and continuing to fill until the working pressure is achieved, then venting to atmosphere, and finally pulling down to a vacuum (optional for A2L). This process shall be repeated until no refrigerant is within the system (optional for A2L). When the final oxygen-free nitrogen charge is used, the system shall be vented down to atmospheric pressure to be able to perform the required work. Ensure that the outlet for the vacuum pump is not close to any potential ignition sources and working area is well ventilated.

Each unit consists of a blower assembly, refrigerant coil, and controls in an insulated galvanized steel factory-finished enclosure. Knockouts are provided for electrical wiring entrance.

For ease in installation, it is best to make any necessary coil configuration changes before setting air handler in place.

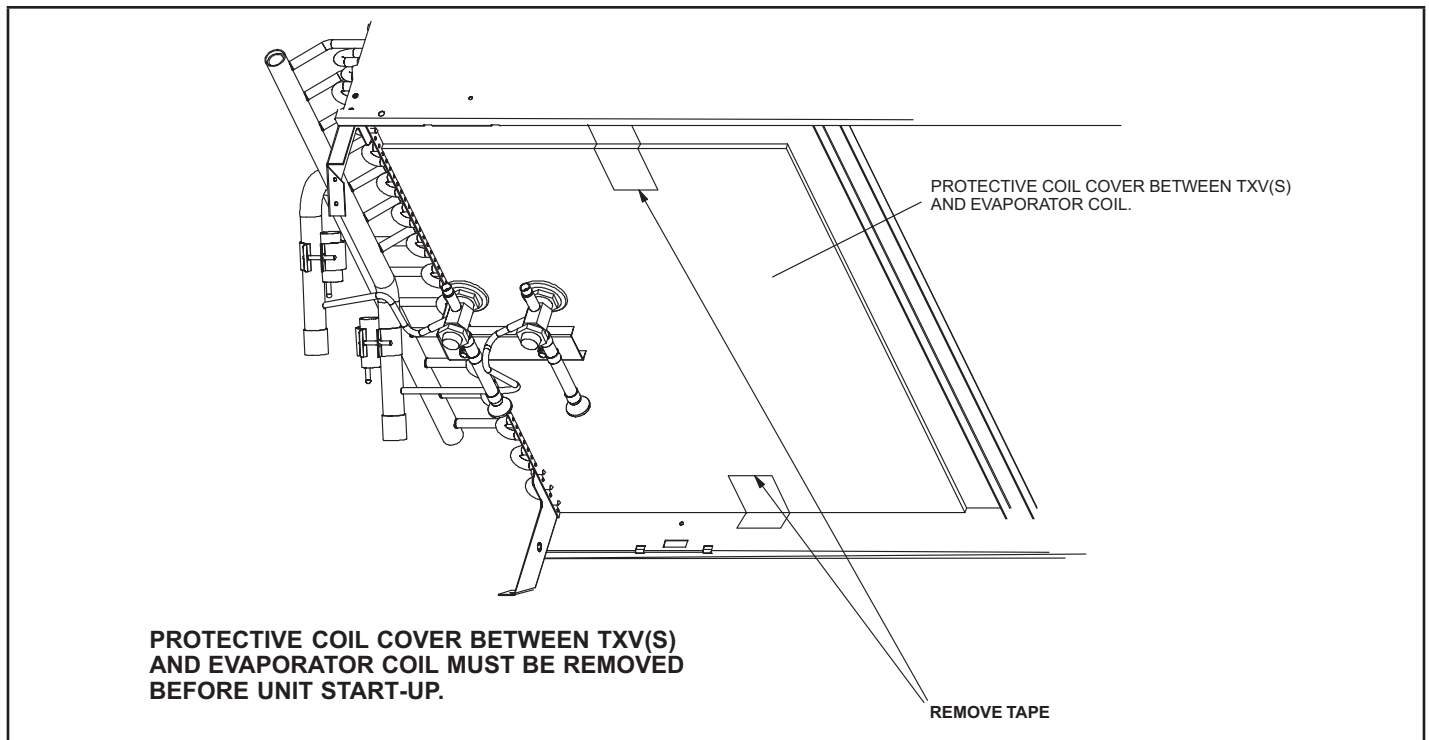

FIGURE 1. Protective Coil Cover Removal

Horizontal Applications

This section provides information regarding drip pan orientation and installation.

Drip Pan Orientation

If the unit is installed for horizontal airflow, the drip pan must be positioned as shown in figure 2, and the drain pan must be positioned as shown in figure 4.

Horizontal Position Drip Pan Installation

- 1 - Remove screws securing side covers. Remove side covers from unit.
- 2 - Remove screws securing the drip pan.
- 3 - Pull drip pan from the unit.
- 4 - Move drip pan to location shown in figure 2. Ensure that insulation parts remain on the bottom of drip pan.
- 5 - Reinstall screws to secure drip pan.
- 6 - Reinstall side covers with screws.

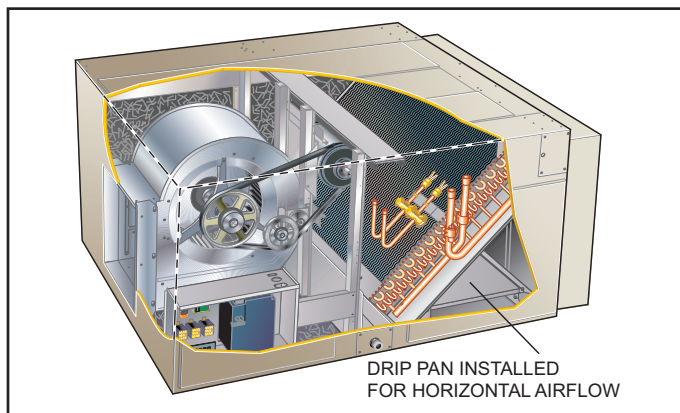

FIGURE 2. Drip Pan in Horizontal Airflow Position

Upflow Applications

This section provides information regarding drip pan orientation and installation.

Drip Pan Orientation

If the unit is installed for upflow airflow, the drip pan must be positioned as shown in figure 3, and the drain pan must be positioned as shown in figure 4.

Upflow Position Drip Pan Installation

- 1 - Remove screws securing side covers. Remove side covers from unit.
- 2 - Remove screws securing the drip pan.
- 3 - Pull drip pan from the unit.
- 4 - Move drip pan to location shown in figure 3. Ensure that insulation parts remain on the bottom of drip pan.
- 5 - Reinstall screws to secure drip pan.
- 6 - Reinstall side covers with screws.

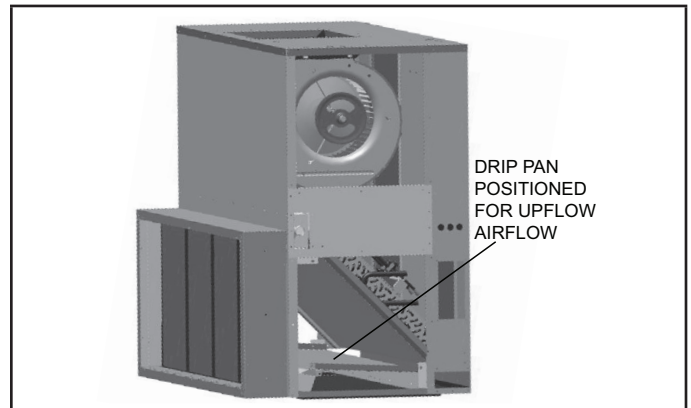

FIGURE 3. Drip Pan in Upflow Airflow Position

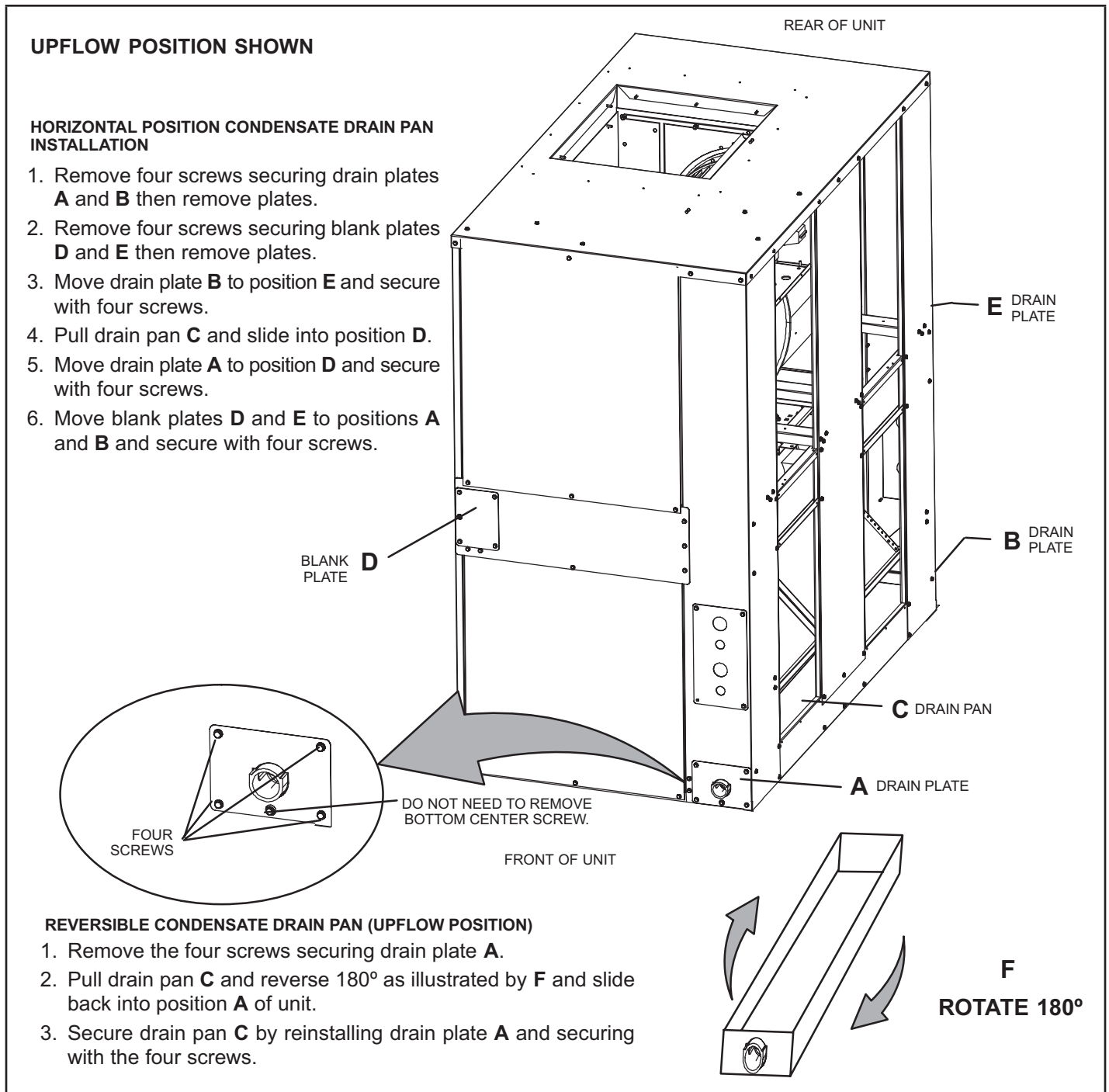

FIGURE 4. Reposition Drain Pan for Horizontal Applications

Sensor Installation / Relocation

Upflow Orientation

Leak detection sensor (LDS) and bracket are factory-installed for up-flow installation. No sensor relocation is required if installing in upflow configuration. Refer to figure 5 for factory-installed leak detection sensor detail.

NOTE – The leak detection sensor needs to be relocated for horizontal configuration.

Horizontal Orientation

- 1 - Remove blower access panel, control box cover and side access panel (See figures 5 and 6).

- 2 - Disconnect the 4-pin sensor cable plug from the A194 control board (see figure 15), then carefully remove the cable from the control box.
- 3 - Cut push-in wire tie securing cable to the mullion bracket.
- 4 - Remove sensor cable from the screw-in wire tie leaving the screw installed in the sheet metal.
- 5 - Remove sensor assembly (bracket, cabled sensor, screws securing bracket to mullion) from up-flow position (shown in figure 5). Do not remove sensor from the bracket, seal the two screw holes.

- 6 - Remove sensor assembly from the unit.
- 7 - With the access panels removed, install sensor assembly to the baffle channel by lining up the holes as shown in figure 6.

NOTE – Install sensor assembly so that the bracket lays between sensor and the coil.

- 8 - Install push-in wire tie on mullion bracket and support channel.

- 9 - Route sensor cable through the push-in ties as shown in figure 6.

NOTE – Pull any excess sensor cable away from blower belt/pulleys before tightening the wire ties.

- 10 - Route the plug end of the cable into the control box and reconnect to A194 control board (see figure 15).

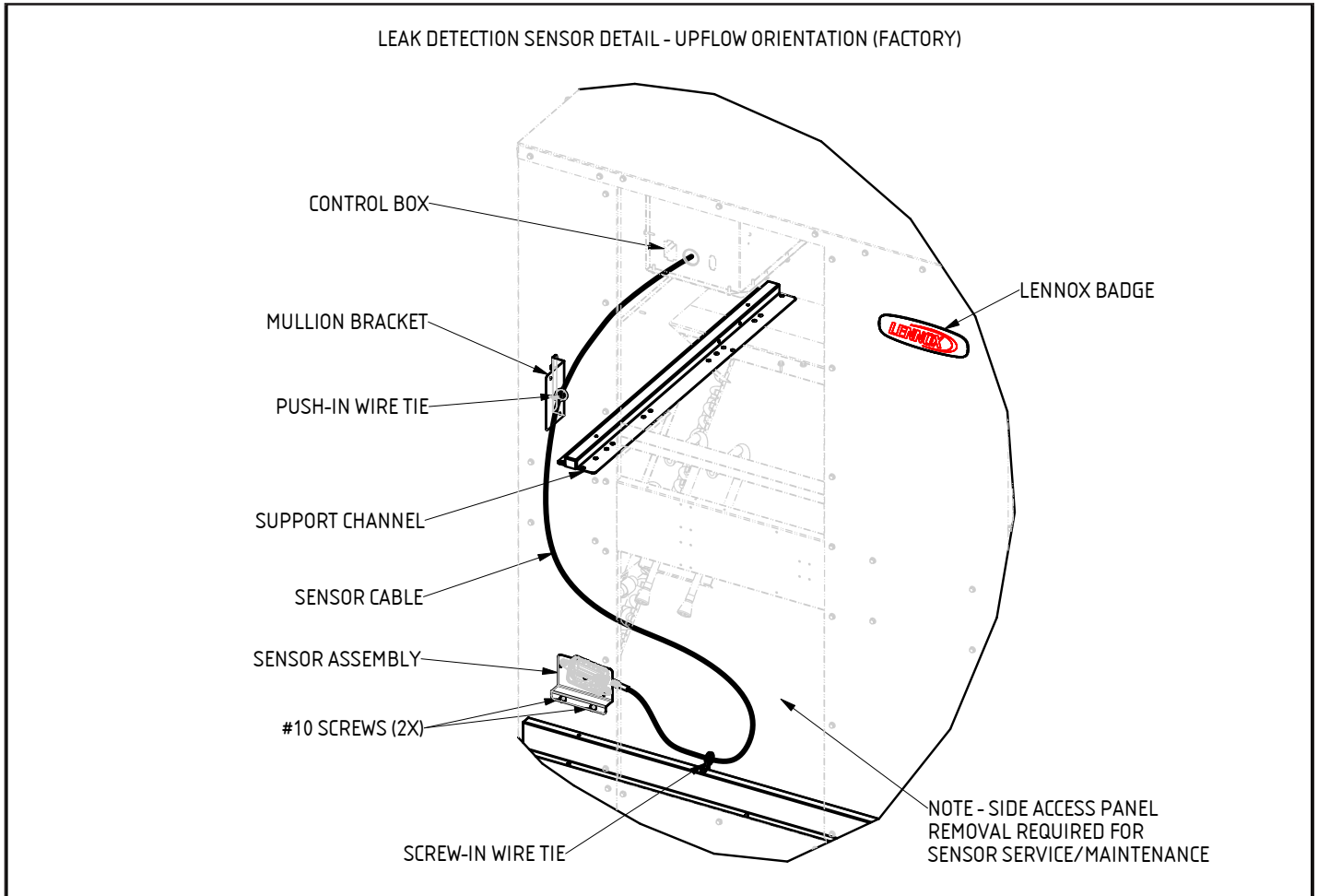
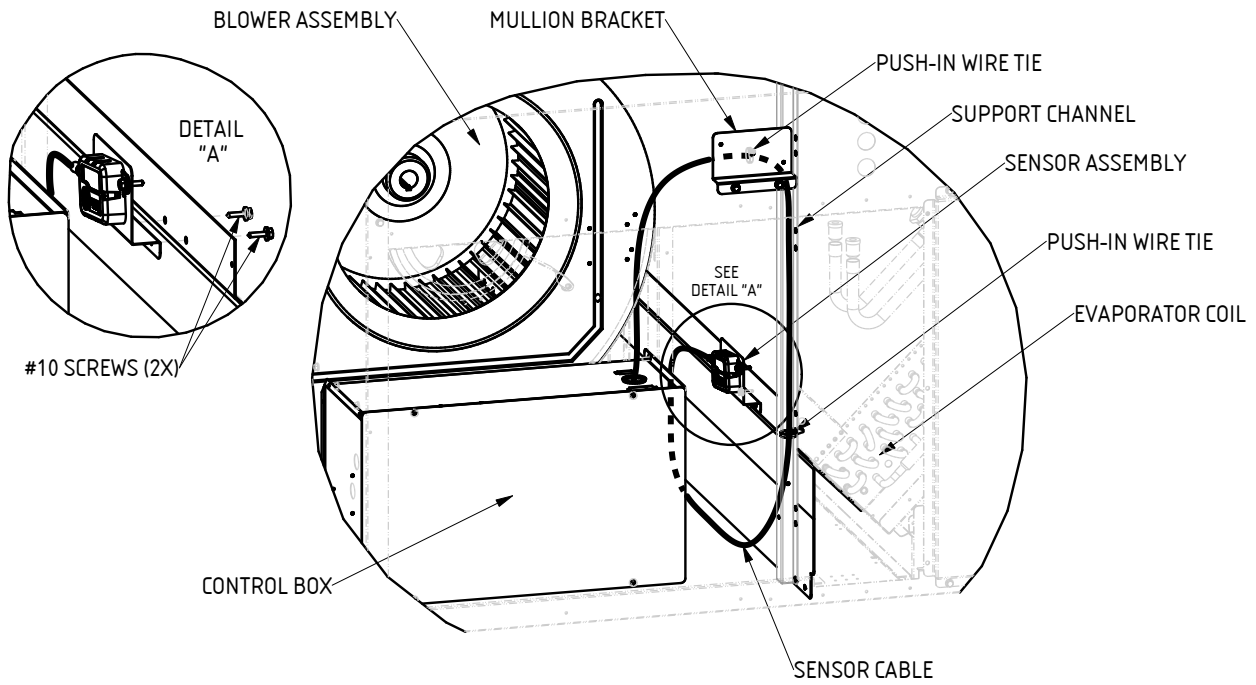

FIGURE 5. LDS Detail (Upflow)

LEAK DETECTION SENSOR DETAIL - HORIZONTAL ORIENTATION



NOTE - PANELS REMOVED FOR ILLUSTRATION PURPOSES ONLY

FIGURE 6. LDS Detail (Horizontal)

Installing Condensate Drain

Before connecting drain line, check drain hole to verify that drain opening is fully open and free of any debris. Also check to make sure that no debris has fallen into the drain pan during installation that may plug up the drain opening.

CONDENSATE DRAIN INSTALLATION

Connect main condensate drain (1 in. N.P.T.) and route downward to an open drain or sump. The drain pan is made with a glass reinforced engineered plastic capable of withstanding typical joint torque but can be damaged with excessive force. Tighten pipe nipple hand tight and turn an additional quarter turn. Do not connect drain to a closed waste system. See figure 7 for typical condensate trap configuration.

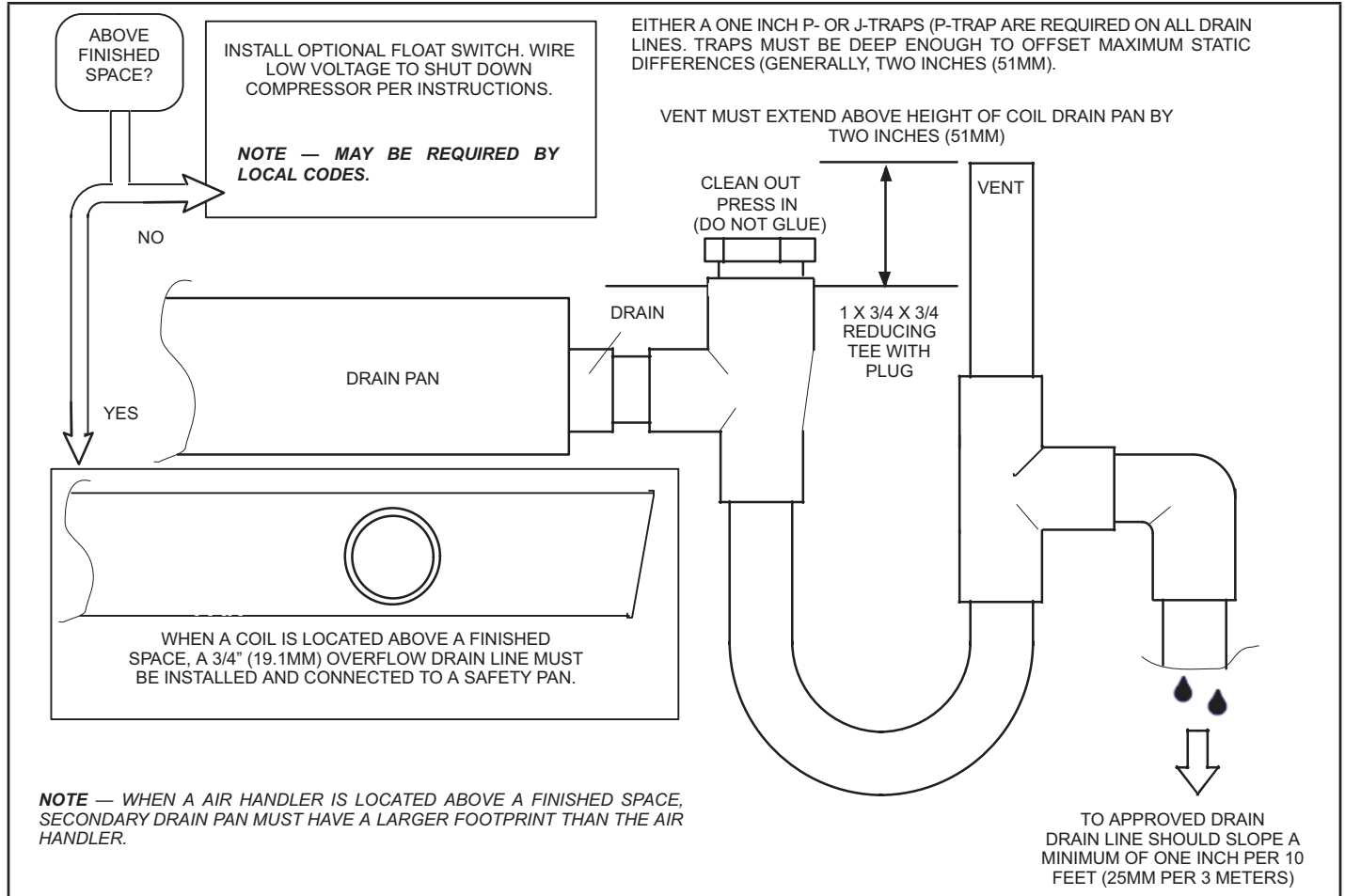

FIGURE 7. Typical Condensate Drain Connections

Freezestat Connections

Single-Compressor Units

- 1 - Leave jumper harness connected to main control harness and S50 jumper plug. Refer to figure 8.
- 2 - Connect S49 and S50 freezestats to appropriate harness connections. S49 will be located at lower end of coil, depending on upflow or horizontal orientation. Refer to figure A (Upflow Orientation) and figure B (Horizontal Orientation) for freezestat locations.

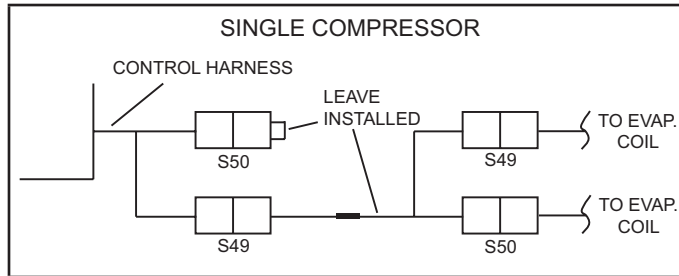

FIGURE 8. Jumper Harness Remains Installed

Two-Compressor Units

- 1 - Remove and discard jumper harness on control harness. Refer to figure 9.
- 2 - Connect S49 and S50 freezestats to appropriate connections in harness. S49 will be located at lower end of coil, depending on upflow or horizontal orientation. S50 will be located at the top of the coil. Refer to figure A (Upflow Orientation) and figure B (Horizontal Orientation) for freezestat locations.

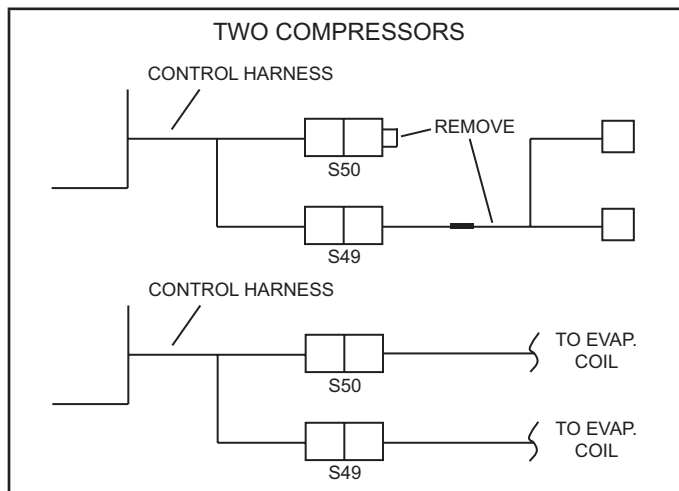

FIGURE 9. Remove and Discard Jumper Harness

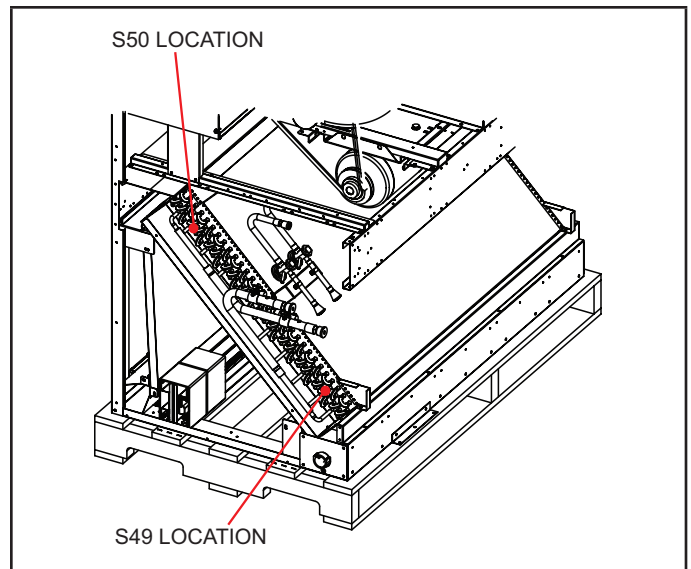

FIGURE A. Upflow Orientation

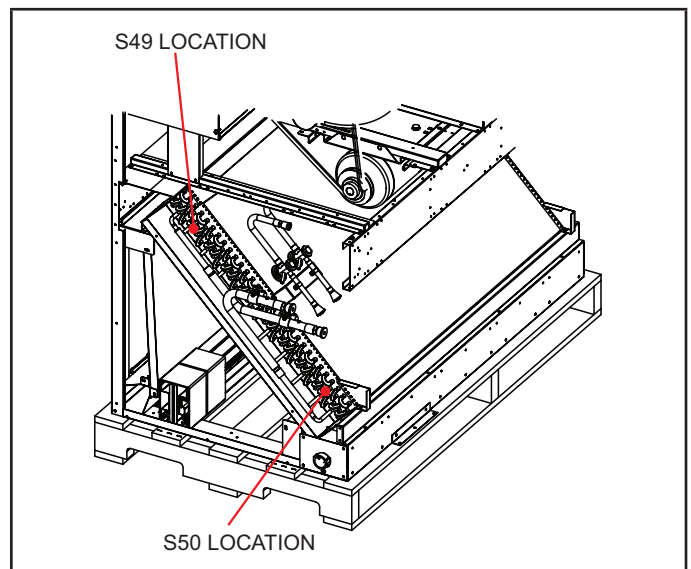

FIGURE B. Horizontal Orientation

Filter Rack Installation

The filter rack cabinet is shipped unassembled inside the unit and must be unpacked and assembled prior to use. Refer to figure 10 to ensure that all necessary components are included before assembly. The cabinet is designed to house 2" MERV 8 or MERV 13 filters, purchased separately.

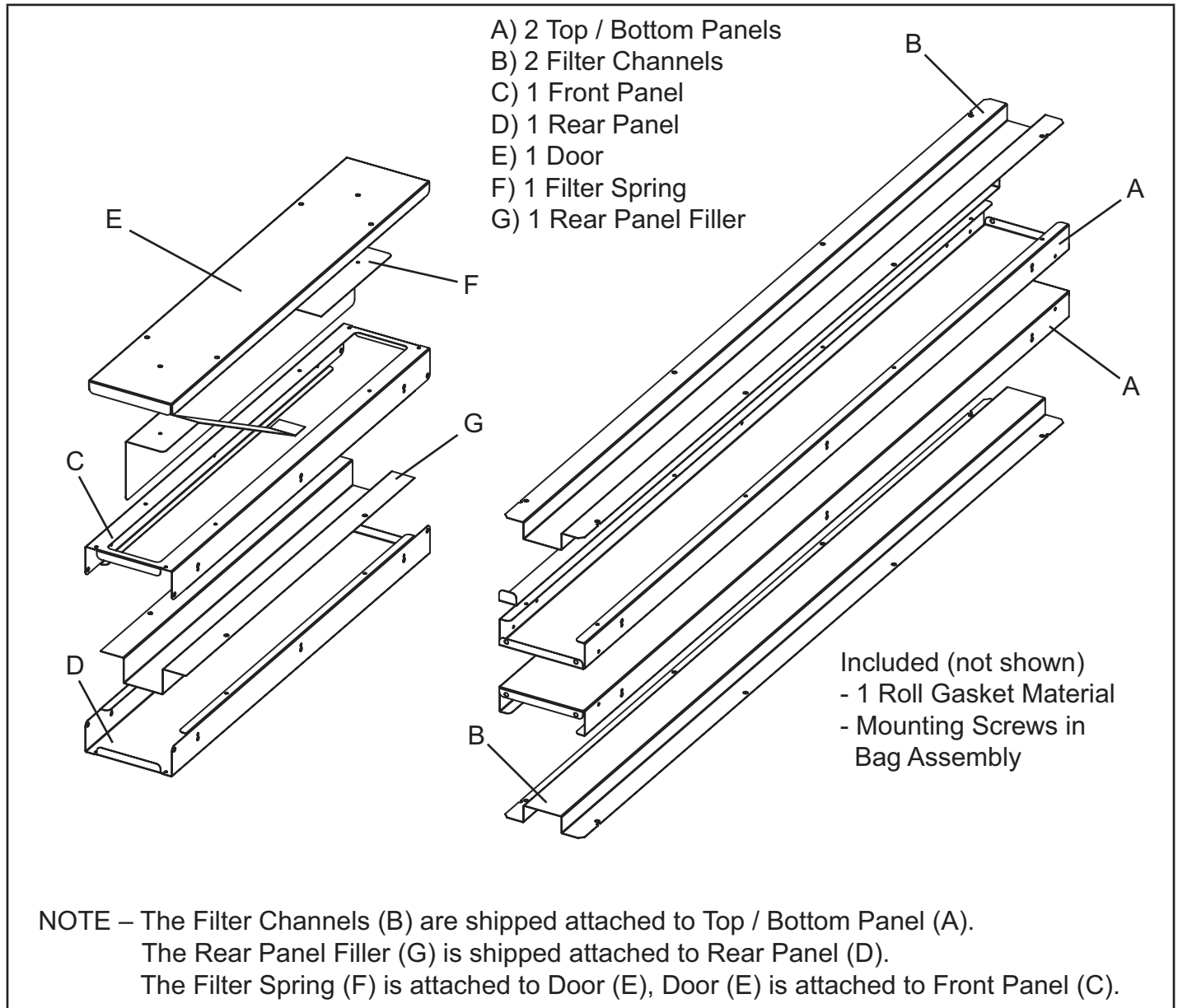

FIGURE 10. Filter Rack Components

Filter Cabinet Assembly

The cabinet sections are designed to be attached together. Align the edges as shown in figure 11.

NOTE – The screws provided to attach the filter rack (#10x16x5/8") are used only on one side. While mounting filter rack on unit, make sure that the side without screws is flush with the unit.

- 1 - Place one Top / Bottom Panel A on a firm surface. Align front panel C into one end of side panel A. Attach Panel C to Panel A as shown in figure 11 using provided screws.

- 2 - Align and attach rear panel D into Top / Bottom Panel A (see figure 12).
- 3 - Align and attach remaining Top / Bottom Panel A into front panel C and rear panel D. Verify that all screws are tight before attaching filter rack to unit (see figure 13).

NOTE – The Filter Channels and Rear Panel Filler are attached to the cabinet after the cabinet is installed on the unit.

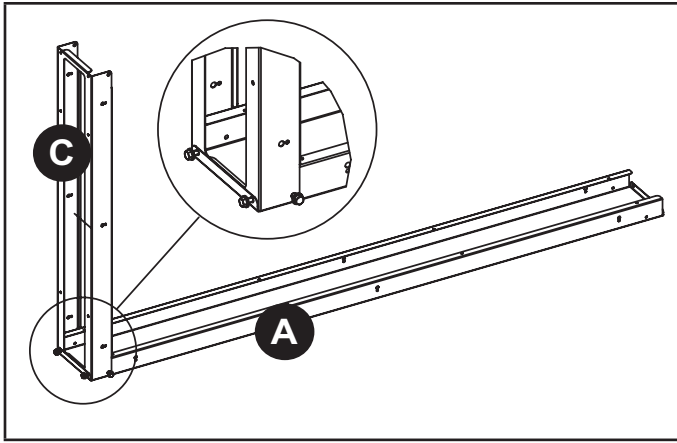

FIGURE 11. Assemble Front Panel (C) to Bottom Panel (A)

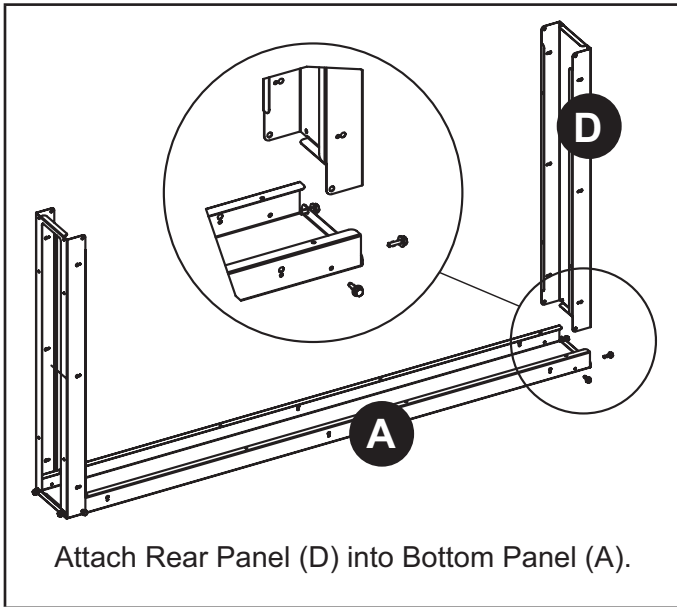

FIGURE 12. Assemble Rear Panel (D) to Bottom Panel (A)

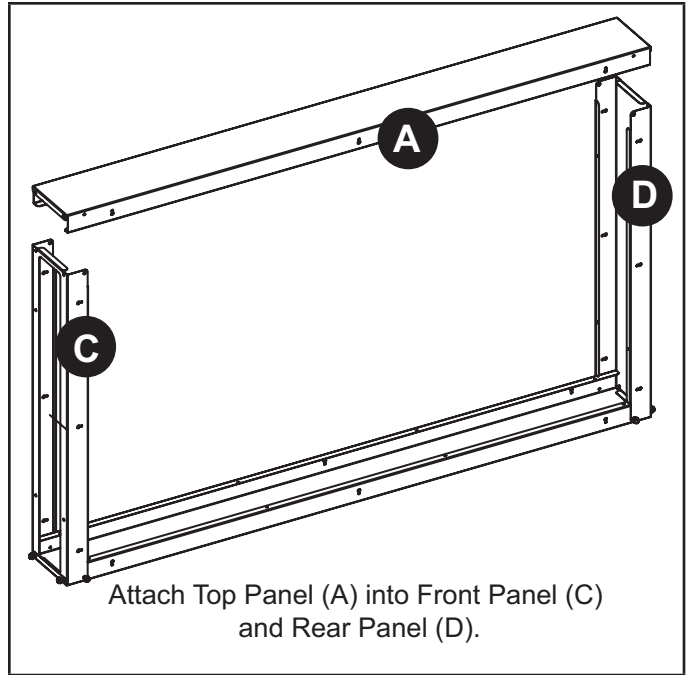

FIGURE 13. Install Top Panel (A)

Filter Cabinet Installation

- 1 - Align the cabinet with the return air opening on the air handler with the access door opening facing outward.
- 2 - Secure the cabinet to the unit using the screws provided (#10x16x5/8").
- 3 - Insert Filter Channel (B) into the cabinet and use the provided screws (#10x16x5/8") to secure them to the cabinet at both the top and bottom. Insert the Rear Panel Filler (G) and attach it to the Rear Panel with the screws provided.
- 4 - Attach the duct to the filter cabinet. Use foil tape to seal all duct joints to prevent dust from entering the air stream.
- 5 - Slide the filters into the filter channel.
- 6 - Attach the filter spring to the cabinet door using the provided (2) #10x16x3/8" screws. Secure the door to the front panel using the provided (4) #10x16x1 screws.
- 7 - Install provided gasket material on all sides of filter access door.

Duct Connections

SIDE RETURN AIR COVER PLATE RELOCATION

UNIT IS SHIPPED FOR INSTALLATION IN AN UPFLOW APPLICATION.

REMOVE SCREWS THAT SECURE SIDE COVER PLATE ON SIDE RETURN AIR OPENING. USE EXISTING SCREWS TO RE-SECURE COVER PLATE OVER BOTTOM OPENING.

INSTALL FILTER RACK PER INSTRUCTIONS BEFORE INSTALLING DUCT FLANGES.

072-090-120-150 MODELS

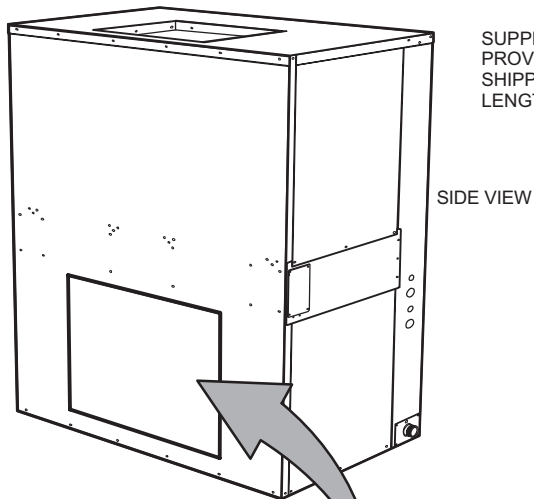

SIDE RETURN AIR COVER PLATE (SHIPPED FROM FACTORY INSTALLED)

NOTE — SIDE RETURN AIR COVER PLATE CAN BE RELOCATED TO BOTTOM RETURN AIR LOCATION.

SUPPLY AND RETURN AIR FLANGES ARE PROVIDED AND ARE STORED INSIDE UNIT FOR SHIPPING. SEE TABLE 2 FOR FLANGE LENGTHS.

180-240 MODELS

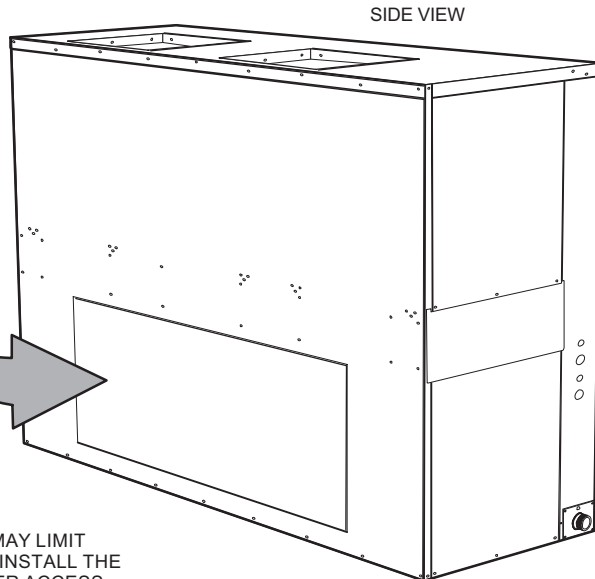

NOTE — ON DUAL-BLOWER UNITS, FLANGES ENCOMPASS BOTH OPENINGS.

INSTALLATION OF FLANGES

ALIGN PROVIDED FLANGES WITH PRE-DRILLED HOLES IN BOTH RETURN AND SUPPLY AIR LOCATIONS AND SECURE WITH FIELD-PROVIDED SHEET METAL SCREWS (#10-16 X 5/8").

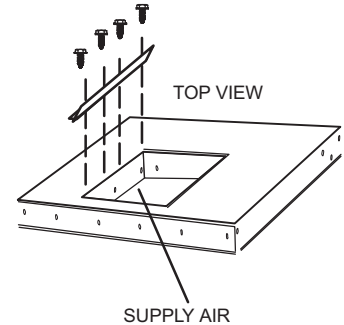

TOP VIEW

SUPPLY AIR

IF A RETURN AIR PLENUM IS NOT USED, INSTALLATION CODES MAY LIMIT INSTALLATION TO SINGLE-STORY STRUCTURES ONLY. DO NOT INSTALL THE SUPPLY AIR PLENUM WITHIN 18 INCHES (457 MM) OF THE BLOWER ACCESS PANEL.

NOTE — Use flexible duct to eliminate vibration.

FIGURE 14. Cover Plate Relocation and Installation of Flanges

TABLE 2. Air Handler Duct Flange Lengths – Inches (mm)

Models	072/090	120/150	180/240
Return air flanges - Common (2)	23-1/4" (591)	23-1/4" (591)	23-1/4" (591)
Return air flanges - Long (2)	45-1/2" (1158)	61-1/2" (1562)	92" (2337)
Discharge air flanges - Common (2)	18-1/2" (470)	18-1/2" (470)	18-1/2" (470)
Discharge air flanges - Long (2)	25-5/8" (651)	25-5/8" (651)	51-3/8" (1305)

Sealing the Unit

Seal the unit so that warm air is not allowed into the cabinet. Warm air introduces moisture, which results in water blow-off problems. This is especially important when the unit is installed in an unconditioned area.

WARNING

There must be an airtight seal between the bottom of the air handler and the return air plenum. Use fiberglass sealing strips, caulking, or equivalent sealing method between the plenum and the air handler cabinet to ensure a tight seal. Return air must not be drawn from a room where this air handler or any gas-fueled appliance (i.e., water heater), or carbon monoxide-producing device (i.e., wood fireplace) is installed.

Wiring

WARNING

Run 24V Class II wiring only through specified low voltage opening. Run line voltage wiring only through specified high voltage opening. Do not combine voltage in one opening.

NATIONAL AND LOCAL CODE RESTRICTIONS

- Wiring must conform to the current National Electric Code ANSI/NFPA No. 70, or Canadian Electric Code Part I, CSA Standard C22.1, and local building codes. Refer to following wiring diagrams. See unit nameplate for minimum circuit ampacity and maximum over-current protection size.
- Electrical wiring, disconnect means and over-current protection are to be supplied by the installer. Refer to the air handler rating plate for maximum over-current protection, minimum circuit ampacity, as well as operating voltage. Select the proper supply circuit conductors in accordance with tables 310-16 and 310-17 in the National Electric Code, ANSI/NFPA No. 70 or tables 1 through 4 in the Canadian Electric Code, Part I, CSA Standard C22.1.
- The power supply must be sized and protected according to the specifications supplied on the product.

Separate openings have been provided for 24V low voltage and line voltage. Refer to the dimension illustration for specific location.

Refer to wiring diagram installed on the cabinet access panel for unit wiring and thermostat connections. Refer to figure 15 for low voltage unit wiring connections.

CAUTION

USE COPPER CONDUCTORS ONLY.

WARNING

Fire Hazard. Use of aluminum wire with this product may result in a fire, causing property damage, severe injury or death. Use copper wire only with this product.

WARNING

ELECTROSTATIC
DISCHARGE
(ESD)
Precautions and
Procedures

Electrostatic discharge can affect electronic components. Take care during unit installation and service to protect the unit's electronic controls. Precautions will help to avoid control exposure to electrostatic discharge by putting the unit, the control and the technician at the same electrostatic potential. Touch hand and all tools on an unpainted unit surface before performing any service procedure to neutralize electrostatic charge.

WARNING



Electric Shock Hazard. Can cause injury or death. Unit must be properly grounded in accordance with national and local codes. Line voltage is present at all components when unit is not in operation on units with single-pole contactors. Disconnect all remote electric power supplies before opening access panel. Unit may have multiple power supplies.

WARNING

Failure to use properly sized wiring and circuit breaker may result in property damage. Size wiring and circuit breaker(s) per Product Specifications bulletin (EHB) and unit rating plate.

LOW VOLTAGE WIRING
FROM THERMOSTAT

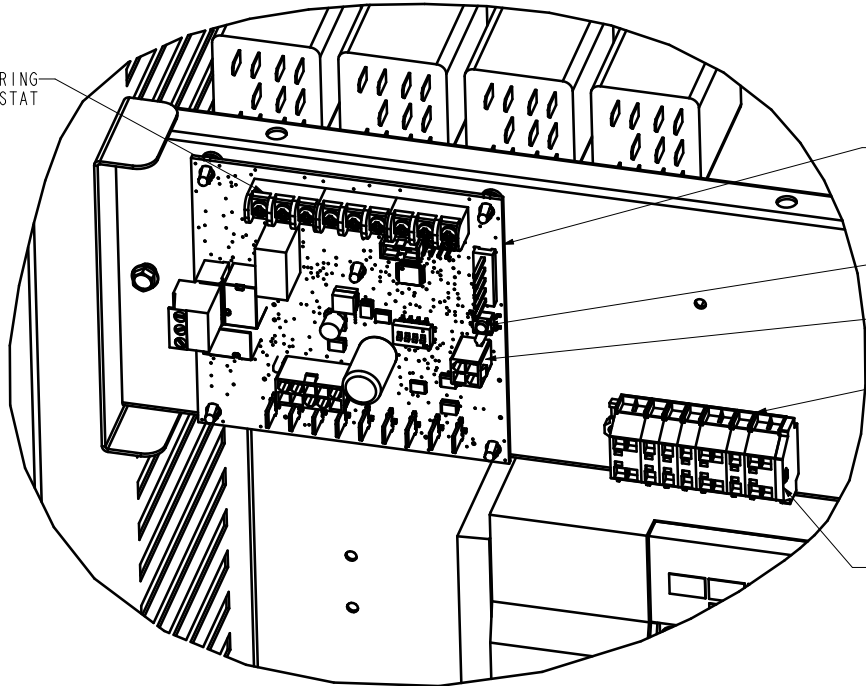

REFRIGERANT LEAK
DETECTION CONTROL
(A194)

TEST/RESET
BUTTON

LEAK DETECTION
SENSOR CONNECTION

LOW VOLTAGE WIRING
FROM OUTDOOR UNIT

TERMINAL STRIP
(TB14)

LOW VOLTAGE WIRING

FIGURE 15. Low Voltage Wiring

Blower Motor Belt Tensioning Adjustment

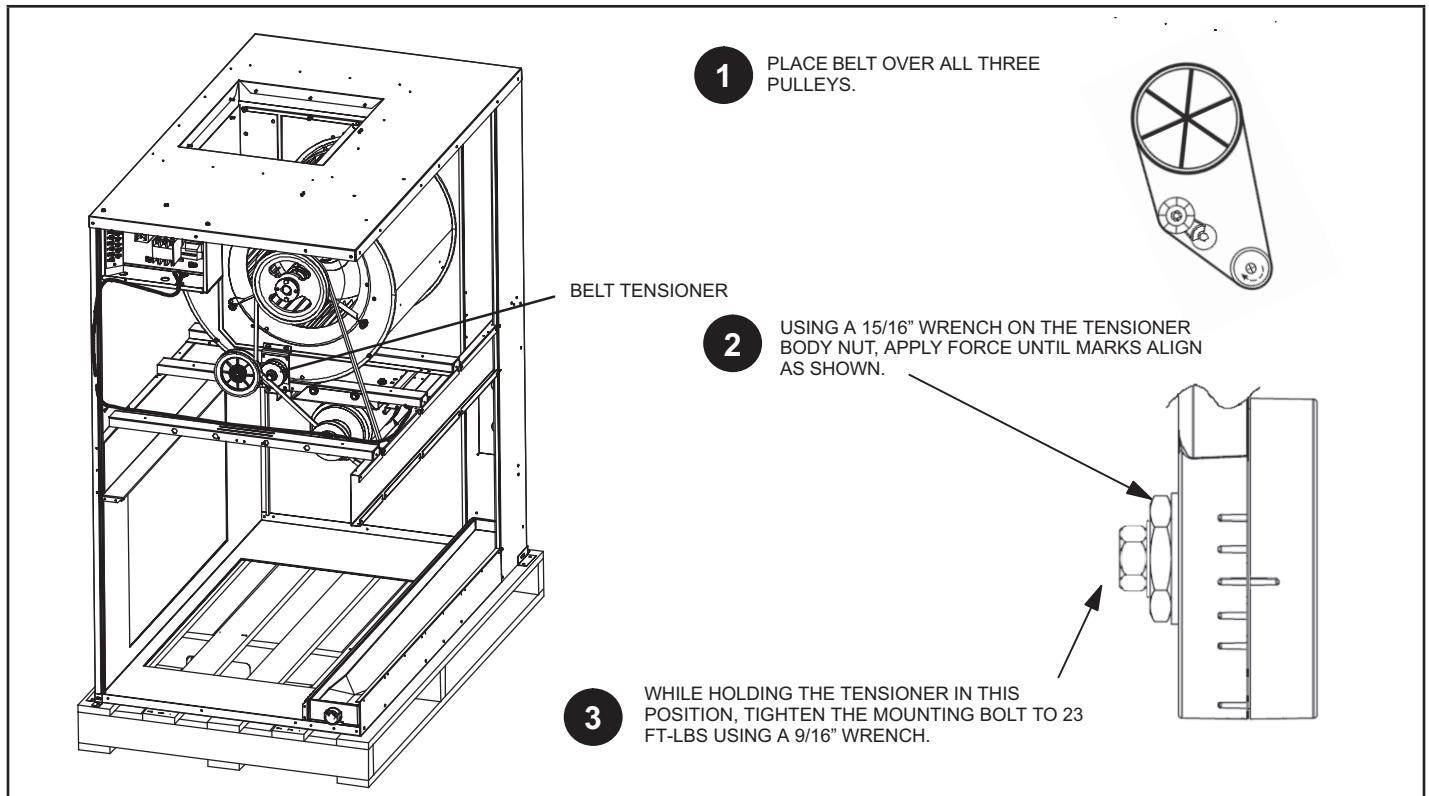

FIGURE 17. Typical Blower Belt Tensioner Adjustment Procedure

Pulley Alignment

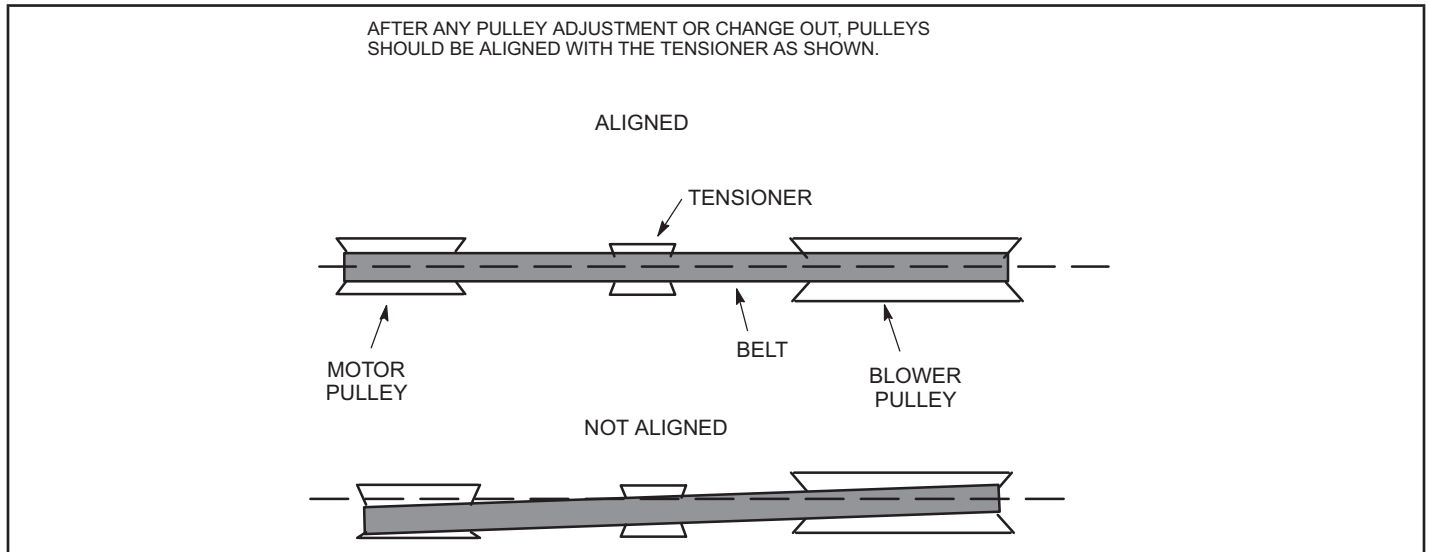

FIGURE 18. Typical Pulley Alignment

Air Volume Adjustment

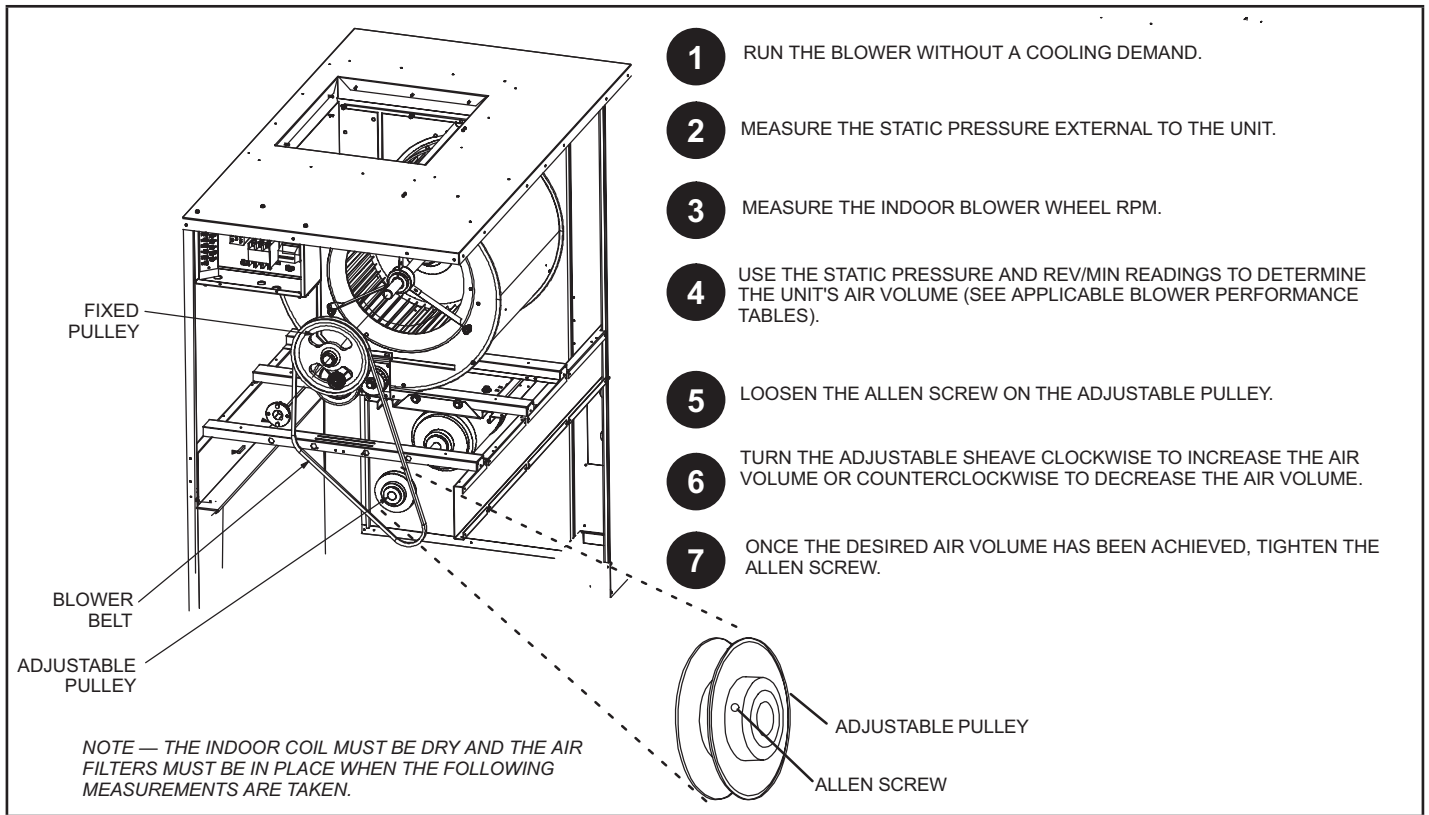

FIGURE 19. Typical Air Volume Adjustment Procedure

Air Volume Adjustment – Caution

Air flow exceeding the CFM per ton listed below for each unit is NOT RECOMMENDED in high humidity applications.

Model	CFM per Ton
090	450 CFM per ton
150	400 CFM per ton
240	400 CFM per ton

Blower Data

Blower Drive Specifications, 60Hz

Static*	RPM Range	Motor HP		072	090	120	150	180	240
		Nominal	Maximum						
Low	563 - 798	1.5	1.5	O					
Standard	798 - 1033	1.5	1.5	S					
Low	562 - 796	2	2		O				
Standard	796 - 1030	2	2		S				
Low	560 - 793	2	2			O			
Standard	793 - 1027	3	3			S			
Low	653 - 887	3	3				O		
Standard	846 - 1081	5	5				S		
Low	598 - 820	3	3					O	
Standard	820 - 1041	5	5					S	
Low	689 - 875	5	5						O
Standard	810 - 1036	7.5	7.5						S

*Low Static – 460V models only.

Supply Air Inverter Startup

A-General

Units equipped with a supply air inverter are available which provide three blower speeds. The blower will operate at lower speeds when cooling demand is low and higher speeds when cooling demand is high. This results in lower energy consumption.

Inverter-driven blowers will operate at high speed during ventilation (blower “G” only signal) but can be adjusted to operate at low speed.

Medium speed is approximately 3/4 of the full-speed rpm.

Low speed is approximately 2/3 of the full-speed RPM.

B-Set Maximum Blower CFM

- 1 - Initiate a blower (G) only signal from the room thermostat or control system.
- 2 - Adjust the blower pulley to deliver the full (high speed) CFM in the typical manner. See *Determining Unit CFM* in the Blower Operation and Adjustment section.

C-Set Blower Speed During Ventilation

To save energy during ventilation, the blower speed can be set to low. This is accomplished by changing the ventilation speed switch on the VFD control board to “LO”. See figure 17.

NOTE – On units equipped with an economizer, set damper minimum position as shown in the next section. After adjusting the low speed minimum position, the ventilation speed switch will be in the “LO” position.

D-Set Damper Minimum Position (Units with Economizer)

To maintain required minimum ventilation air volumes when the unit is in the occupied mode, two minimum damper positions must be set. A high and a low speed potentiometer are provided on the VFD control board to adjust minimum damper position. See figure 19.

Set High Speed Minimum Position

- 1 - Initiate a blower (G) only AND occupied demand from the room thermostat or control system.
- 2 - Set the ventilation speed switch on the VFD control board to “HI”.
- 3 - Rotate the high speed potentiometer on the VFD control board to set the high speed minimum damper position.
- 4 - Measure the intake air CFM. If the CFM is lower than the design specified CFM for ventilation air, use the potentiometer to increase the damper percent open. If the CFM is higher than specified, decrease the damper percent open.

NOTE – Intake air CFM can also be determined using the outdoor air temperature, return air temperature and mixed air temperature. Refer to the economizer or outdoor air damper installation instructions.

Set Low/Medium Speed Minimum Position

- 1 - Initiate a blower (G) only AND occupied demand from the room thermostat or control system.
- 2 - Set the ventilation speed switch on the VFD control board to “LO”.
- 3 - Rotate the low speed potentiometer on the VFD control board to set the low speed minimum damper position. This set point also applies to Medium blower speed.
- 4 - Measure the intake air CFM. If the CFM is lower than the design specified CFM for ventilation air, use the potentiometer to increase the damper percent open. If the CFM is higher than specified, decrease the damper percent open.

NOTE – Intake air CFM can also be determined using the outdoor air temperature, return air temperature and mixed air temperature. Refer to the economizer or outdoor air damper installation instructions.

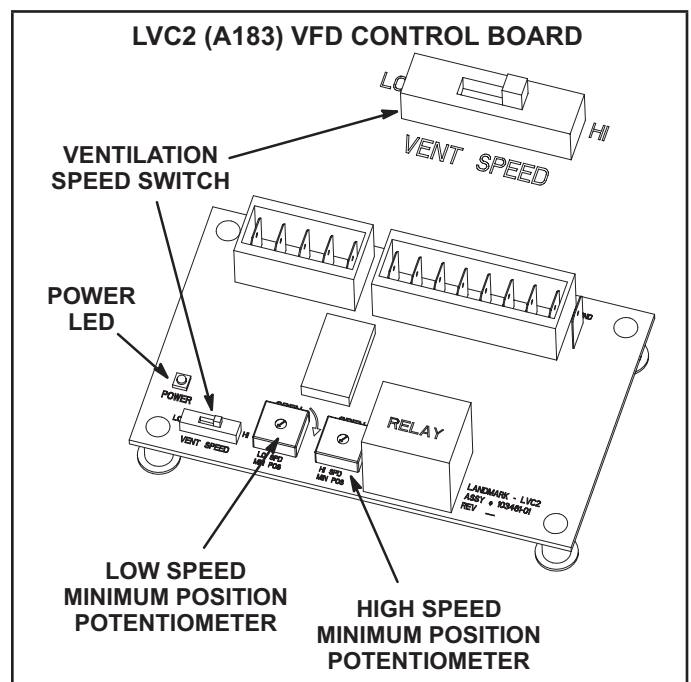

FIGURE 20

Thermostat Compatibility

Thermostats that preserve memory settings are compatible with the RDS Non-Communicating Blower Control Board. Examples include:

- Battery-powered thermostats
- Analog thermostats
- Smart thermostats
- Late-model programmable thermostats
- *Early-generation digital and programmable thermostats may not retain the operation mode and temperature set-points after a power outage.*

The following scenarios are likely to occur when occupants are not available to adjust the thermostat setpoints as the system is recovering from leak detection and resuming normal operation:

- Heating could be lost during a cold night
- Cooling could be lost during a hot day
- The thermostat could reset to an incorrect temperature setpoint

Compatibility Verification

Complete the following process to determine whether the thermostat is compatible with the RDS Non-Communicating Blower Control Board.

- 1 - Change the thermostat's current setpoint and operating mode.
- 2 - Power cycle the breaker to the air handler.

NOTE – Wait five (5) minutes before supplying power to the furnace breaker.

- 3 - Note whether the thermostat maintained its setpoints and operating mode.
 - a. If the thermostat maintained the settings, the thermostat is compatible with the RDS Non-Communicating Blower Control Board.
 - b. If the thermostat did not maintain its setpoint and/ or operating mode, the thermostat is not compatible with the RDS Non-Communicating Blower Control Board. Recommend replacing with a compatible thermostat.

Refrigerant Leak Detection System

This air handler is equipped with a Refrigerant Leak Detection System. The system consists of the RDS Non-Communicating Blower Control Board (RDSC) in the control compartment and a R454B Refrigerant Sensor near the coil. The Modes of Operation for the RDS Non-Communicating Blower Control Board are Initializing, Normal, Leak Detected, and Fault.

MODES OF OPERATION

Initializing

The RDS Non-Communicating Blower Control Board is establishing connection with the refrigerant detection sensor and sensor is “warming up”.

Normal

The HVAC system is functioning normally, i.e., responding to thermostat demand signals. The RDS Non-Communicating Blower Control Board has not detected a refrigerant leak.

Leak Detected (Mitigation)

When the RDS Non-Communicating Blower Control Board detects a refrigerant leak:

- 1 - The RDS Non-Communicating Blower Control Board shuts off the (R) output (24VAC power) to the thermostat, which de-energizes the outdoor unit compressor and heat sources, such as gas and/or electric strip heat. No heating or cooling demands will be met.
- 2 - The RDS Non-Communicating Blower Control Board activates the blower ventilation speed (G). The blower purges refrigerant from the cabinet, plenum, and ductwork.

NOTE – The blower ventilation (G) speed is determined by SW1 position on LVC2 (A183) control board (refer to the Supply Air Inverter Startup Section).

- 3 - After the RDS Non-Communicating Blower Control Board determines the refrigerant levels are below the safety threshold, the blower will continue to function for an additional seven (7) minutes.
- 4 - After the blower sequence is complete, the HVAC system resumes normal operation.

NOTE – The HVAC system may not maintain a cooling or heating setpoint if a significant leak exists. Any refrigerant leaks that remain unaddressed for an extended time may cause the HVAC system to shut down on a low refrigerant pressure limit condition.

Fault/Service

When a fault is detected within the RDS Non-Communicating Blower Control Board, the indoor unit blower engages and remains engaged at a constant output until the fault is cleared.

DIAGNOSTIC CODES / TROUBLESHOOTING

The RDS Non-Communicating Blower Control Board is equipped with a multicolor LED. The LED signals the operational state of the RDS Non-Communicating Blower Control Board. To review the operational states, refer to table 3, LED Operational Modes / Troubleshooting, for details. Red diagnostic codes indicate a specific RDS Non-Communicating Blower Control Board issue. To determine the issue and possible troubleshooting actions, refer to table 4, Red LED Diagnostic Codes / Troubleshooting.

The RDS Non-Communicating Blower Control Board is equipped with a Test/Reset button. The Test button can be used to complete several functions, depending on the mode of operation of the RDS Non-Communicating Blower Control Board. Table 5 lists the functions of the Test button during each mode of operation.

TABLE 3. LED Operational Modes / Troubleshooting

Operating Mode	LED Status	Action
Initializing	Flashing green	None
Monitoring	Solid green*	None
Mitigation (Leak Detected)	Flashing blue	Check coil tubes for leak. Repair the issue and restart the equipment.
Fault / Service	Solid blue, interrupted by red flash code	Refer to table for troubleshooting guidance.

*Solid green interrupted by a blue flash indicates the mitigation process has previously occurred.

TABLE 4. Red LED Diagnostic Codes / Troubleshooting

Red Wink	Applies to Individual Sensor(s)	Issue	Action
1	Yes	RDS Sensor Fault	Replace sensor
2	No	VFD alarm / Drain pan overflow	Check VFD for alarms, remedy alarms present. If float switch is installed, verify proper switch mounting location, depth in pan, unobstructed condensate drain line; correct as needed.
3	Yes	Incompatible sensor installed	Replace sensor
4	Yes	Sensor communication issue	Check sensor connection. Ensure connection is clean and tight.
5	No	R-input not available	Check for 24VAC power connected to thermostat R terminal on the RDSC. 24VAC power should only be provided at A194-R quick connection for the RDSC to function.
6	No	Invalid configuration of sensor count	Not applicable

TABLE 5. Test Button Functions

Operation Mode	Press the Test Button to...	Press	Action
Monitoring	Trigger a leak detection response. Verify all equipment is wired correctly into the RDSC (after installation).	Short	Clear purge-counter if prior mitigation has occurred; test mitigation
		Long	Reset control
Mitigating (Leak Detected)	Reset the RDSC to a normal mode of operation after a previous leak has been detected and purged from the HVAC system.	Short	If testing mitigation, end test
Fault/Service	Reset the RDSC after troubleshooting and resolving a fault condition. If the fault is not resolved, the RDSC will enter the Fault mode again.	Short	Reevaluate fault condition - if cleared, return to monitoring, otherwise update indicator.
		Long	Reset control

Normal System Operation

When the RDS Non-Communicating Blower control is in Monitoring Mode, the indoor unit and outdoor unit cycle on demand from the room thermostat. Refer to interconnect diagrams (figures 21 and 22) for demand signals passed from the indoor unit to the outdoor unit.

For details on the indoor unit component operation based on thermostat demand and the outdoor unit type, see appropriate table:

1. Single-Compressor Cooling Matchups (up to 2 COOL and 2 HEAT) - tables 6 and 7.
2. Two-Compressor Matchups (up to 3 COOL and 2 HEAT) - tables 8, 9 and 10.

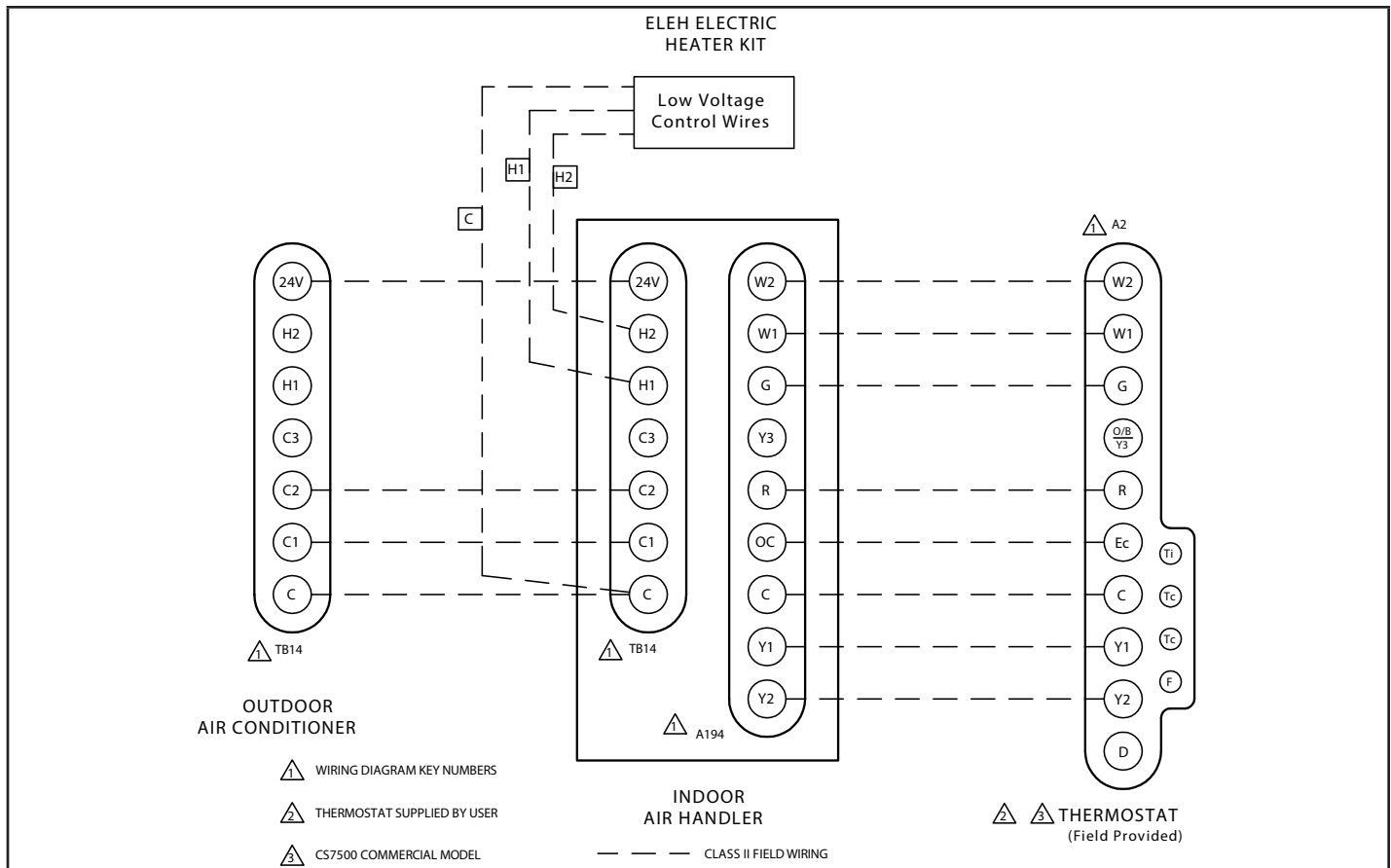

FIGURE 21. Typical Field Wiring – Single Compressor

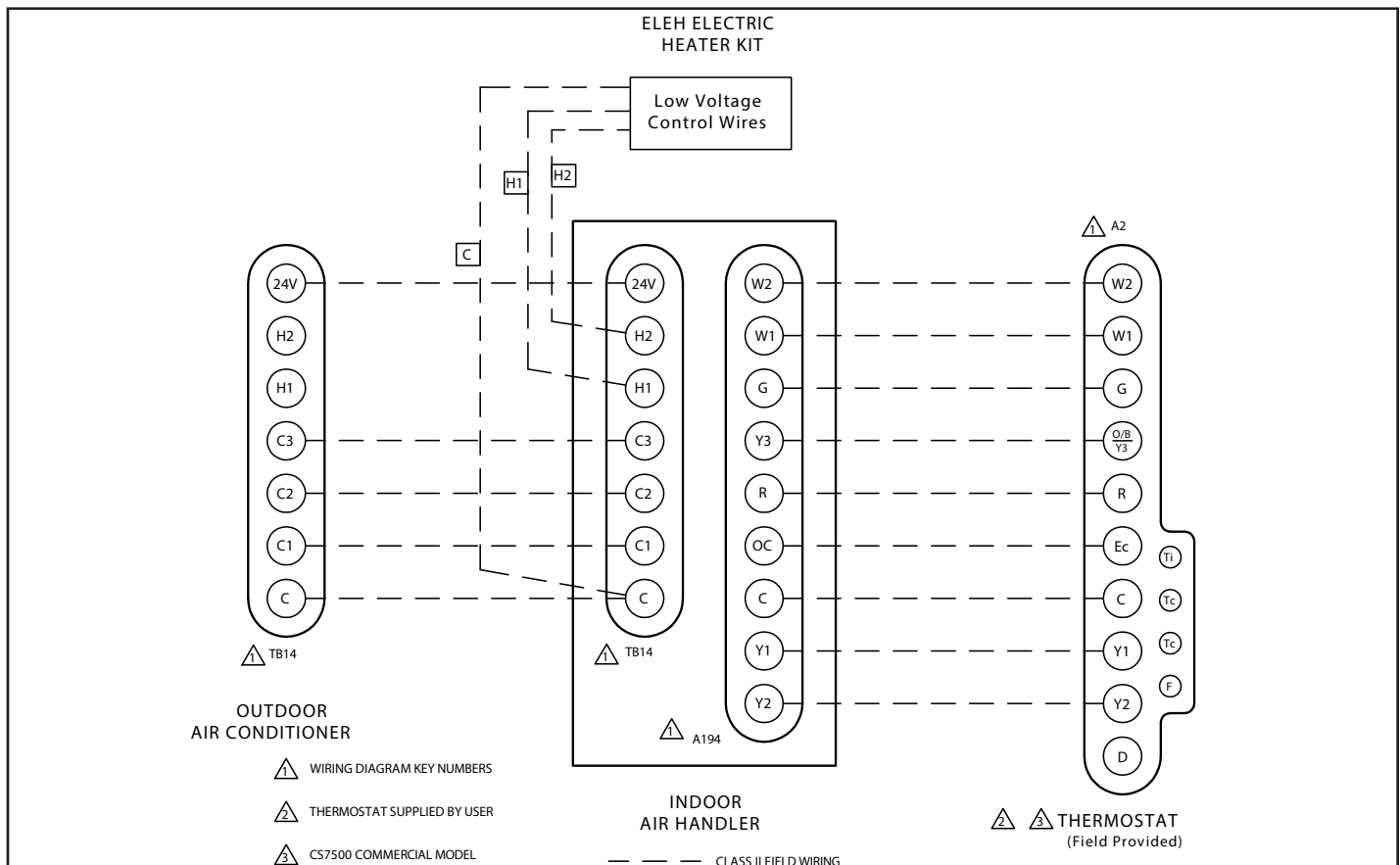

FIGURE 22. Typical Field Wiring – Two Compressors

Single-Compressor Cooling Matchups (up to 2 COOL and 2 HEAT)

Table 6. EL072KA-EL072KCSS; EL090KA-EL090KCSS

Demands	Condition	Unit Operation											Damper (Economizer)	
		T'stat, DDC ⁴ (TB1)	Outdoor Air Suitability ³	Outputs to EL_XC (TB1)	Indoor Unit Blower Speeds (B3)			Outdoor Unit Compressor		Outdoor Unit Fans				
					LOW	MED	HIGH	(B1)	(B2)	(B4)	(B5)	(B21)	(B22)	OCC
G	----	----	X ¹	----	X ¹	OFF	----	OFF	----	----	----	----	VENT ¹	CLOSED
Y1	NO	C1	X	----	----	LOW	----	ON	----	----	----	----	MIN LO	CLOSED
Y1+Y2	NO	C1+C2	----	----	----	HIGH	----	ON	----	----	----	----	MIN LO	CLOSED
W1 or W2	----	----	----	----	X	OFF	----	OFF	----	----	----	----	MIN HI	CLOSED
Y1	YES	----	----	----	X	OFF	----	OFF	----	----	----	----	MOD ²	MOD ²
Y1+Y2	YES	C1	----	----	X	LOW	----	ON	----	----	----	----	MOD ²	MOD ²

Footnotes:

¹VENT = Ventilation speed and damper position selectable using LVC2 control board, Switch SW1.

²MOD = Damper Modulating

³Suitability for Free Cooling with Damper Installed

⁴Field installed jumper wire required between TB1-C2 and TB1-C3

 <- Unit Operation without Damper installed

Table 7. EL120KA-EL120KCSS

Demands	Condition	Unit Operation											Damper (Economizer)	
		T'stat, DDC ⁴ (TB1)	Outdoor Air Suitability ³	Outputs to EL_XC (TB1)	Indoor Unit Blower Speeds (B3)			Outdoor Unit Compressor		Outdoor Unit Fans				
					LOW	MED	HIGH	(B1)	(B2)	(B4)	(B5)	(B21)	(B22)	OCC
G	----	----	X ¹	----	X ¹	OFF	----	OFF	OFF	----	----	----	VENT ¹	CLOSED
Y1	NO	C1	X	----	----	LOW	----	ON	ON	----	----	----	MIN LO	CLOSED
Y1+Y2	NO	C1+C2	----	----	X	HIGH	----	ON	ON	----	----	----	MIN LO	CLOSED
W1 or W2	----	----	----	----	X	OFF	----	OFF	OFF	----	----	----	MIN HI	CLOSED
Y1	YES	----	----	----	X	OFF	----	OFF	OFF	----	----	----	MOD ²	MOD ²
Y1+Y2	YES	C1	----	----	X	LOW	----	ON	ON	----	----	----	MOD ²	MOD ²

Footnotes:

¹VENT = Ventilation speed and damper position selectable using LVC2 control board, Switch SW1.

²MOD = Damper Modulating

³Suitability for Free Cooling with Damper Installed

⁴Field installed jumper wire required between TB1-C2 and TB1-C3

 <- Unit Operation without Damper installed

Two-Compressor Matchups (up to 3 COOL and 2 HEAT)

Table 8. EL120KA-EL120KCSD

Demands	Condition	Unit Operation											Damper (Economizer)	
		T'stat, DDC ⁴ (TB1)	Outdoor Air Suitability ³	Outputs to EL_XC (TB1)	Indoor Unit Blower Speeds (B3)			Outdoor Unit Compressor		Outdoor Unit Fans				
					LOW	MED	HIGH	(B1)	(B2)	(B4)	(B5)	(B21)	(B22)	OCC
G	----	----	X ¹	----	X ¹	OFF	OFF	OFF	OFF	----	----	----	VENT ¹	CLOSED
Y1	NO	C1	X	----	----	LOW	OFF	ON	ON	----	----	----	MIN LO	CLOSED
Y1+Y2	NO	C1+C2	----	X	----	LOW	LOW	ON	ON	----	----	----	MIN LO	CLOSED
Y1+Y2+Y3	NO	C1+C2+C3	----	----	X	HIGH	HIGH	ON	ON	----	----	----	MIN HI	CLOSED
W1 or W2	----	----	----	----	X	OFF	OFF	OFF	OFF	----	----	----	MIN HI	CLOSED
Y1	YES	----	----	----	X	OFF	OFF	OFF	OFF	----	----	----	MOD ²	MOD ²
Y1+Y2	YES	C1	----	X	----	LOW	OFF	ON	ON	----	----	----	MOD ²	MOD ²
Y1+Y2+Y3	YES	C1+C3	----	----	X	HIGH	OFF	ON	ON	----	----	----	MOD ²	MOD ²

Footnotes:

¹VENT = Ventilation speed and damper position selectable using LVC2 control board, Switch SW1.

²MOD = Damper Modulating

³Suitability for Free Cooling with Damper Installed

 <- Unit Performance without Damper installed

Table 9. EL150KA-EL150KCSD

Demands	Condition	Unit Operation													
		T'stat, DDC (TB1)	Outdoor Air Suitability ³	Outputs to EL_XC (TB1)	Indoor Unit Blower Speeds (B3)			Outdoor Unit Compressor		Outdoor Unit Fans				Damper (Economizer)	
					LOW	MED	HIGH	(B1)	(B2)	(B4)	(B5)	(B21)	(B22)	OCC	UNOCC
G	----	----	X ¹	----	X ¹	OFF	OFF	OFF	OFF	----	----	VENT ¹	CLOSED		
Y1	NO	C1	X	----	----	LOW	OFF	ON	OFF	----	----	MIN LO	CLOSED		
Y1+Y2	NO	C1+C2	----	X	----	LOW	LOW	ON	ON	----	----	MIN LO	CLOSED		
Y1+Y2+Y3	NO	C1+C2+C3	----	----	X	HIGH	HIGH	ON	ON	----	----	MIN HI	CLOSED		
W1 or W2	----	----	----	----	X	OFF	OFF	OFF	OFF	----	----	MIN HI	CLOSED		
Y1	YES	----	----	----	X	OFF	OFF	OFF	OFF	----	----	MOD ²	MOD ²		
Y1+Y2	YES	C1	----	X	----	LOW	OFF	ON	OFF	----	----	MOD ²	MOD ²		
Y1+Y2+Y3	YES	C1+C3	----	----	X	HIGH	OFF	ON	OFF	----	----	MOD ²	MOD ²		

Footnotes:

¹VENT = Ventilation speed and damper position selectable using LVC2 control board, Switch SW1.

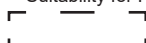
²MOD = Damper Modulating

³Suitability for Free Cooling with Damper Installed

 <- Unit Operation without Damper installed

Table 10. EL180KA-EL180KCSD; EL240KA-EL240KCSD

Demands	Condition	Unit Operation													
		T'stat, DDC (TB1)	Outdoor Air Suitability ³	Outputs to EL_XC (TB1)	Indoor Unit Blower Speeds (B3)			Outdoor Unit Compressor		Outdoor Unit Fans				Damper (Economizer)	
					LOW	MED	HIGH	(B1)	(B2)	(B4)	(B5)	(B21)	(B22)	OCC	UNOCC
G	----	----	X ¹	----	X ¹	OFF	OFF	OFF	OFF	OFF	OFF	OFF	VENT ¹	CLOSED	
Y1	NO	C1	X	----	----	LOW	OFF	ON	ON	OFF	OFF	MIN LO	CLOSED		
Y1+Y2	NO	C1+C2	----	X	----	LOW	LOW	ON	ON	ON	ON	MIN LO	CLOSED		
Y1+Y2+Y3	NO	C1+C2+C3	----	----	X	HIGH	HIGH	ON	ON	ON	ON	MIN HI	CLOSED		
W1 or W2	----	----	----	----	X	OFF	OFF	OFF	OFF	OFF	OFF	MIN HI	CLOSED		
Y1	YES	----	----	----	X	OFF	OFF	OFF	OFF	OFF	OFF	MOD ²	MOD ²		
Y1+Y2	YES	C1	----	X	----	LOW	OFF	ON	ON	OFF	OFF	MOD ²	MOD ²		
Y1+Y2+Y3	YES	C1+C3	----	----	X	HIGH	OFF	ON	ON	OFF	OFF	MOD ²	MOD ²		

Footnotes:

¹VENT = Ventilation speed and damper position selectable using LVC2 control board, Switch SW1.

²MOD = Damper Modulating

³Suitability for Free Cooling with Damper Installed

 <- Unit Operation without Damper installed

Blower Drive Components

Blower Drive Components, 60Hz

Unit	Static*	Adjustable Sheave		Fixed Sheave		Belt		Bushing		Key		Motor HP
		OEM No	MFG No	OEM No	MFG No	OEM No	MFG No	OEM No	MFG No	OEM No	Dimensions	
072	Low	79J0301	1VP40 x 7/8	49K4101	BK85 x 1	100245-25	AX54	-	-	LB-21259	1/4x1/4x1-1/2	1.5
	Standard	P-8-2187	1VP50 x 7/8	49K4101	BK85 x 1	100245-26	AX55	-	-	LB-21259	1/4x1/4x1-1/2	1.5
090	Low	79J0301	1VP40 x 7/8	49K4101	BK85 x 1	100245-25	AX54	-	-	LB-21259	1/4x1/4x1-1/2	2
	Standard	P-8-2187	1VP50 x 7/8	49K4101	BK85 x 1	100245-26	AX55	-	-	LB-21259	1/4x1/4x1-1/2	2
120	Low	79J0301	1VP40 x 7/8	49K4101	BK85 x 1	100245-25	AX54	-	-	LB-21259	1/4x1/4x1-1/2	2
	Standard	P-8-2187	1VP50 x 7/8	49K4101	BK85 x 1	100245-26	AX55	-	-	LB-21259	1/4x1/4x1-1/2	3
150	Low	P-8-1488	1VP44 x 7/8	49K4101	BK85 x 1	100245-25	AX54	-	-	LB-21259	1/4x1/4x1-1/2	3
	Standard	41C1301	1VP60 x 1-1/8	79J2701	BK95 x 1	100245-10	BX60	-	-	LB-21259	1/4x1/4x1-1/2	5
180	Low	79J0301	1VP40 x 7/8	105617-04	BK85 x 1-3/16	100245-52	BX54	-	-	105594-01	1/4x1/4x1-3/4	3
	Standard	P-8-1977	1VP50 x 1-1/8	105617-04	BK85 x 1-3/16	78L5301	BX57	-	-	105594-01	1/4x1/4x1-3/4	5
240	Low	P-8-1977	1VP50 x 1-1/8	100788-05	BK100H	59A5001	BX59	105616-02	H-1-3/16	105594-01	1/4x1/4x1-3/4	5
	Standard	78L5501	1VP60 x 1-3/8	100788-05	BK100H	93J9801	BX61	105616-02	H-1-3/16	105594-01	1/4x1/4x1-3/4	7.5

*Low static - 460V models only.

Blower Performance

NOTE - All data is measured external to the unit with dry coil and standard 2 in. air filters in place.

072 BLOWER PERFORMANCE

Air Volume CFM	STATIC PRESSURE EXTERNAL – Inches Water Gauge																	
	0.2		0.3		0.4		0.5		0.6		0.7		0.8		0.9		1	
CFM	RPM	BHP	RPM	BHP	RPM	BHP	RPM	BHP	RPM	BHP	RPM	BHP	RPM	BHP	RPM	BHP	RPM	BHP
1200	411	0.11	453	0.2	494	0.26	535	0.31	584	0.32	638	0.31	688	0.32	729	0.37	762	0.46
1300	416	0.14	458	0.23	499	0.29	541	0.34	589	0.36	642	0.35	692	0.36	733	0.41	765	0.5
1400	421	0.16	463	0.25	505	0.32	546	0.37	594	0.39	647	0.38	696	0.4	736	0.45	768	0.54
1500	427	0.19	468	0.28	510	0.35	551	0.4	599	0.42	651	0.42	699	0.44	739	0.49	771	0.58
1600	432	0.22	473	0.3	515	0.38	556	0.44	604	0.46	656	0.46	703	0.48	742	0.53	774	0.62
1700	438	0.24	479	0.33	520	0.41	561	0.47	609	0.49	660	0.5	707	0.52	745	0.58	777	0.67
1800	444	0.27	485	0.36	526	0.44	567	0.5	614	0.53	665	0.54	711	0.56	749	0.62	780	0.71
1900	450	0.3	491	0.39	532	0.47	573	0.53	619	0.57	670	0.58	715	0.6	752	0.67	783	0.76
2000	457	0.33	497	0.42	538	0.5	579	0.57	625	0.6	674	0.62	719	0.65	756	0.71	786	0.8
2100	464	0.36	504	0.45	544	0.53	585	0.6	631	0.64	679	0.66	723	0.69	759	0.76	790	0.85
2200	471	0.4	511	0.49	551	0.57	591	0.64	636	0.68	684	0.7	728	0.74	763	0.81	794	0.9
2300	478	0.43	518	0.52	558	0.61	598	0.68	643	0.72	690	0.75	732	0.79	767	0.86	797	0.95
2400	485	0.47	525	0.56	565	0.65	605	0.72	649	0.77	695	0.79	737	0.83	771	0.91	802	1.01
2500	493	0.51	533	0.6	572	0.69	612	0.76	655	0.81	701	0.84	742	0.88	776	0.96	806	1.06
2600	500	0.55	540	0.64	580	0.73	619	0.8	662	0.85	707	0.89	747	0.93	780	1.01	810	1.12
2700	508	0.59	548	0.68	588	0.77	627	0.84	670	0.9	713	0.93	752	0.99	785	1.07	815	1.18
2800	516	0.63	556	0.72	596	0.81	635	0.88	678	0.94	720	0.98	758	1.04	790	1.13	820	1.25
2900	523	0.67	564	0.76	604	0.85	644	0.92	686	0.98	727	1.03	763	1.1	795	1.19	826	1.31
3000	531	0.71	573	0.8	613	0.89	653	0.96	694	1.03	734	1.08	769	1.15	801	1.26	831	1.38

Air Volume CFM	STATIC PRESSURE EXTERNAL – Inches Water Gauge																			
	1.1		1.2		1.3		1.4		1.5		1.6		1.7		1.8		1.9		2	
CFM	RPM	BHP	RPM	BHP	RPM	BHP	RPM	BHP	RPM	BHP	RPM	BHP	RPM	BHP	RPM	BHP	RPM	BHP	RPM	BHP
1200	790	0.55	817	0.64	844	0.7	871	0.75	897	0.8	924	0.85	951	0.9	979	0.96	1008	1.01	1036	1.07
1300	793	0.59	820	0.68	847	0.74	874	0.79	900	0.85	927	0.9	954	0.95	982	1.01	1011	1.06	1039	1.12
1400	796	0.63	823	0.72	850	0.78	877	0.84	903	0.89	930	0.95	958	1	986	1.06	1014	1.11	1043	1.18
1500	799	0.68	827	0.76	853	0.82	880	0.88	906	0.94	933	0.99	961	1.05	989	1.11	1018	1.17	1046	1.23
1600	802	0.72	830	0.8	857	0.87	883	0.93	909	0.99	936	1.04	964	1.1	992	1.16	1021	1.23	1050	1.29
1700	805	0.76	833	0.84	860	0.91	886	0.97	913	1.03	940	1.1	967	1.16	996	1.22	1025	1.28	1054	1.35
1800	808	0.81	837	0.89	864	0.96	890	1.02	916	1.08	943	1.15	971	1.21	999	1.28	1029	1.35	1058	1.42
1900	812	0.85	840	0.94	867	1.01	894	1.07	920	1.14	946	1.2	974	1.27	1003	1.34	1032	1.41	1062	1.48
2000	815	0.9	844	0.98	871	1.06	898	1.12	924	1.19	950	1.26	978	1.33	1007	1.4	1036	1.47	1066	1.55
2100	819	0.95	848	1.04	876	1.11	902	1.18	928	1.25	954	1.32	982	1.39	1011	1.47	1040	1.54	1070	1.62
2200	823	1	852	1.09	880	1.16	907	1.24	932	1.31	958	1.38	986	1.46	1015	1.54	1045	1.61	1074	1.69
2300	827	1.06	857	1.14	885	1.22	912	1.3	937	1.37	962	1.45	990	1.53	1020	1.61	1049	1.69	1078	1.77
2400	832	1.11	862	1.2	890	1.28	917	1.36	942	1.44	967	1.52	995	1.6	1024	1.68	1053	1.76	1083	1.85
2500	836	1.17	867	1.26	896	1.34	923	1.43	949	1.51	973	1.59	1000	1.67	1029	1.76	1058	1.84	1087	1.92
2600	841	1.23	872	1.32	901	1.41	929	1.49	955	1.58	979	1.66	1006	1.75	1034	1.83	1063	1.92	1091	2.01
2700	846	1.29	877	1.39	907	1.48	935	1.57	962	1.66	986	1.74	1012	1.83	1039	1.91	1067	2	1096	2.09
2800	852	1.36	883	1.46	913	1.55	941	1.64	968	1.73	992	1.82	1017	1.91	1044	2	1072	2.08	1100	2.17
2900	857	1.43	889	1.52	919	1.62	947	1.71	974	1.81	998	1.9	1023	1.99	1049	2.08	1077	2.17	1105	2.26
3000	863	1.49	894	1.6	925	1.69	953	1.79	979	1.89	1004	1.99	1028	2.08	1054	2.17	1081	2.26	1109	2.35

090 BLOWER PERFORMANCE

Air Volume CFM	STATIC PRESSURE EXTERNAL – Inches Water Gauge																	
	0.2		0.3		0.4		0.5		0.6		0.7		0.8		0.9		1	
CFM	RPM	BHP	RPM	BHP	RPM	BHP	RPM	BHP	RPM	BHP	RPM	BHP	RPM	BHP	RPM	BHP	RPM	BHP
1600	444	0.24	485	0.33	527	0.4	568	0.45	617	0.47	669	0.46	715	0.49	752	0.55	782	0.65
1700	451	0.27	492	0.36	534	0.43	575	0.49	623	0.51	674	0.5	719	0.53	756	0.6	786	0.7
1800	458	0.3	499	0.39	541	0.46	582	0.52	630	0.54	680	0.55	724	0.58	760	0.65	790	0.75
1900	466	0.33	507	0.42	548	0.5	589	0.56	636	0.58	686	0.59	729	0.62	764	0.7	794	0.8
2000	474	0.37	514	0.46	555	0.53	596	0.6	643	0.62	691	0.63	734	0.67	769	0.75	799	0.85
2100	482	0.4	522	0.49	563	0.57	603	0.64	650	0.67	697	0.68	739	0.72	773	0.8	803	0.9
2200	490	0.44	531	0.53	571	0.61	611	0.68	657	0.71	704	0.73	745	0.77	778	0.85	808	0.95
2300	499	0.48	539	0.57	579	0.65	619	0.72	664	0.75	710	0.77	750	0.82	783	0.9	814	1.01
2400	508	0.52	548	0.61	588	0.69	627	0.76	672	0.8	717	0.82	756	0.87	788	0.96	819	1.07
2500	517	0.56	557	0.65	597	0.73	636	0.8	680	0.84	724	0.87	762	0.93	794	1.02	825	1.13
2600	526	0.61	566	0.69	606	0.77	645	0.84	688	0.88	731	0.92	768	0.98	800	1.08	831	1.2
2700	535	0.65	576	0.74	615	0.81	655	0.88	697	0.93	738	0.97	774	1.04	806	1.15	837	1.26
2800	545	0.69	586	0.78	625	0.85	665	0.92	706	0.97	746	1.02	781	1.1	812	1.21	844	1.33
2900	555	0.73	596	0.82	636	0.9	675	0.97	715	1.02	754	1.08	788	1.17	819	1.28	850	1.4
3000	566	0.78	606	0.86	646	0.94	685	1.01	725	1.07	762	1.14	795	1.24	826	1.35	857	1.47
3100	577	0.82	618	0.91	657	0.98	696	1.06	734	1.13	770	1.2	802	1.31	833	1.43	864	1.55
3200	589	0.87	629	0.95	668	1.03	706	1.11	744	1.19	778	1.27	810	1.38	840	1.5	872	1.62
3300	601	0.93	641	1	679	1.08	717	1.17	753	1.25	787	1.35	817	1.46	848	1.58	879	1.7
3400	614	0.98	653	1.06	691	1.14	727	1.23	763	1.32	795	1.42	825	1.54	855	1.66	886	1.78
3500	627	1.05	665	1.13	702	1.21	738	1.3	772	1.4	803	1.51	833	1.63	863	1.75	894	1.86
3600	641	1.11	678	1.19	714	1.28	749	1.37	782	1.48	812	1.59	841	1.71	871	1.83	901	1.95

Air Volume CFM	STATIC PRESSURE EXTERNAL – Inches Water Gauge																			
	1.1		1.2		1.3		1.4		1.5		1.6		1.7		1.8		1.9		2	
CFM	RPM	BHP	RPM	BHP	RPM	BHP	RPM	BHP	RPM	BHP	RPM	BHP	RPM	BHP	RPM	BHP	RPM	BHP	RPM	BHP
1600	811	0.75	838	0.82	865	0.88	891	0.94	918	1	945	1.06	973	1.12	1001	1.18	1030	1.25	1059	1.31
1700	815	0.79	842	0.87	869	0.93	895	0.99	922	1.06	949	1.12	977	1.18	1006	1.24	1035	1.31	1063	1.38
1800	819	0.84	847	0.92	873	0.98	899	1.04	926	1.11	953	1.17	981	1.24	1010	1.31	1039	1.37	1068	1.44
1900	823	0.89	851	0.97	878	1.03	904	1.1	930	1.16	958	1.23	986	1.3	1015	1.37	1044	1.44	1073	1.51
2000	828	0.94	856	1.02	883	1.08	909	1.15	935	1.22	962	1.29	991	1.36	1020	1.44	1049	1.51	1078	1.58
2100	833	0.99	861	1.07	888	1.14	914	1.21	939	1.28	967	1.36	995	1.43	1025	1.5	1054	1.58	1083	1.66
2200	838	1.05	867	1.13	893	1.2	919	1.27	945	1.35	972	1.42	1000	1.5	1030	1.58	1059	1.65	1088	1.73
2300	844	1.11	872	1.19	899	1.26	925	1.34	950	1.41	977	1.49	1006	1.57	1035	1.65	1064	1.73	1093	1.81
2400	849	1.17	878	1.25	906	1.32	931	1.4	956	1.48	983	1.56	1012	1.65	1041	1.73	1070	1.81	1099	1.89
2500	855	1.23	885	1.32	912	1.39	939	1.47	963	1.56	989	1.64	1018	1.72	1046	1.81	1075	1.89	1104	1.97
2600	862	1.3	891	1.38	919	1.46	946	1.55	971	1.63	996	1.72	1024	1.8	1052	1.89	1081	1.97	1110	2.06
2700	868	1.37	898	1.45	927	1.54	953	1.63	978	1.71	1003	1.8	1030	1.89	1058	1.97	1087	2.06	1115	2.15
2800	875	1.44	905	1.53	934	1.61	961	1.71	985	1.8	1010	1.88	1037	1.97	1064	2.06	1092	2.15	1121	2.24
2900	882	1.51	912	1.6	941	1.69	968	1.79	992	1.88	1017	1.97	1043	2.06	1070	2.15	1098	2.24	1126	2.33
3000	889	1.58	919	1.68	948	1.77	974	1.87	999	1.97	1024	2.06	1049	2.15	1076	2.24	1104	2.33	1132	2.43
3100	896	1.65	926	1.75	955	1.86	981	1.96	1006	2.05	1030	2.15	1055	2.24	1082	2.33	1110	2.43	1138	2.53
3200	903	1.73	933	1.84	962	1.94	988	2.04	1012	2.14	1036	2.24	1061	2.33	1088	2.43	1116	2.53	1144	2.63
3300	910	1.81	940	1.92	968	2.03	994	2.13	1018	2.23	1042	2.33	1067	2.43	1094	2.53	1122	2.63	1150	2.74
3400	917	1.89	947	2.01	975	2.12	1000	2.23	1024	2.33	1048	2.43	1074	2.53	1100	2.63	1128	2.74	1156	2.84
3500	924	1.98	954	2.09	981	2.21	1006	2.32	1030	2.43	1055	2.53	1080	2.63	1106	2.74	1134	2.84	1162	2.95
3600	932	2.07	960	2.19	987	2.3	1012	2.42	1036	2.53	1061	2.63	1086	2.74	1113	2.84	1140	2.95	1169	3.05

120 BLOWER PERFORMANCE

Air Volume CFM	STATIC PRESSURE EXTERNAL – Inches Water Gauge																	
	0.2		0.3		0.4		0.5		0.6		0.7		0.8		0.9		1	
CFM	RPM	BHP	RPM	BHP	RPM	BHP	RPM	BHP	RPM	BHP	RPM	BHP	RPM	BHP	RPM	BHP	RPM	BHP
2000	484	0.31	515	0.39	547	0.47	582	0.55	618	0.63	657	0.71	695	0.8	732	0.87	766	0.94
2200	492	0.38	523	0.46	555	0.54	589	0.62	626	0.7	665	0.78	703	0.87	738	0.95	772	1.02
2400	501	0.46	531	0.54	563	0.61	598	0.69	635	0.77	673	0.86	710	0.94	745	1.02	778	1.1
2600	511	0.54	541	0.62	573	0.69	607	0.77	644	0.85	681	0.94	718	1.03	752	1.11	785	1.19
2800	521	0.63	551	0.7	583	0.78	617	0.85	653	0.94	690	1.02	726	1.11	760	1.2	792	1.28
3000	532	0.72	562	0.79	594	0.87	628	0.94	664	1.03	700	1.12	735	1.21	768	1.3	800	1.38
3200	544	0.81	574	0.88	606	0.96	640	1.04	675	1.12	710	1.22	744	1.31	777	1.41	808	1.49
3400	556	0.9	586	0.98	618	1.06	652	1.14	687	1.23	721	1.33	754	1.43	786	1.52	816	1.61
3600	570	1.01	600	1.09	632	1.17	665	1.26	699	1.35	732	1.44	764	1.54	795	1.64	825	1.73
3800	585	1.12	615	1.21	647	1.29	679	1.38	712	1.47	744	1.56	775	1.66	806	1.76	835	1.86
4000	600	1.25	631	1.34	662	1.42	694	1.51	725	1.59	757	1.69	787	1.79	817	1.9	845	2
4200	617	1.38	647	1.47	678	1.55	709	1.64	739	1.73	769	1.82	799	1.93	828	2.04	856	2.15
4400	635	1.53	664	1.61	694	1.69	724	1.78	754	1.87	783	1.96	812	2.07	840	2.19	867	2.32
4600	653	1.68	682	1.76	711	1.84	740	1.92	768	2.01	797	2.11	825	2.23	852	2.36	879	2.51
4800	672	1.83	700	1.91	728	1.99	756	2.08	783	2.17	811	2.28	838	2.41	865	2.56	891	2.71

Air Volume CFM	STATIC PRESSURE EXTERNAL – Inches Water Gauge																			
	1.1		1.2		1.3		1.4		1.5		1.6		1.7		1.8		1.9		2	
CFM	RPM	BHP	RPM	BHP	RPM	BHP	RPM	BHP	RPM	BHP	RPM	BHP	RPM	BHP	RPM	BHP	RPM	BHP	RPM	BHP
2000	798	1.01	828	1.07	857	1.13	885	1.19	912	1.26	938	1.33	963	1.4	987	1.47	1012	1.54	1035	1.62
2200	804	1.09	834	1.15	863	1.22	890	1.29	917	1.36	943	1.43	968	1.5	992	1.58	1017	1.66	1040	1.74
2400	810	1.17	840	1.24	869	1.31	896	1.38	922	1.46	948	1.54	973	1.62	998	1.7	1022	1.78	1045	1.87
2600	816	1.26	846	1.33	875	1.41	902	1.49	928	1.57	954	1.66	978	1.75	1003	1.83	1027	1.92	1051	2.01
2800	823	1.36	853	1.43	881	1.52	908	1.6	934	1.69	959	1.79	984	1.88	1008	1.97	1032	2.07	1056	2.16
3000	830	1.46	859	1.54	887	1.63	914	1.73	940	1.83	965	1.93	990	2.03	1014	2.13	1038	2.22	1062	2.32
3200	838	1.57	867	1.66	894	1.76	920	1.86	946	1.97	971	2.08	996	2.18	1020	2.29	1044	2.39	1068	2.49
3400	846	1.69	874	1.79	901	1.89	927	2	953	2.12	978	2.24	1002	2.35	1026	2.46	1050	2.57	1074	2.68
3600	854	1.82	882	1.92	909	2.04	935	2.16	960	2.29	984	2.41	1008	2.53	1032	2.65	1056	2.76	1080	2.87
3800	864	1.96	891	2.07	917	2.2	942	2.33	967	2.46	991	2.59	1015	2.72	1039	2.84	1062	2.96	1086	3.07
4000	873	2.11	900	2.24	925	2.37	950	2.51	975	2.65	998	2.79	1022	2.92	1045	3.04	1069	3.16	1092	3.28
4200	883	2.28	909	2.41	934	2.56	959	2.7	982	2.85	1006	2.99	1029	3.13	1052	3.25	1075	3.38	1099	3.5
4400	894	2.46	919	2.61	944	2.76	967	2.91	991	3.06	1014	3.21	1037	3.35	1059	3.48	1083	3.6	1106	3.73
4600	905	2.66	930	2.82	953	2.98	977	3.14	1000	3.29	1022	3.44	1045	3.58	1067	3.71	1090	3.84	1114	3.97
4800	916	2.88	941	3.05	964	3.22	987	3.38	1009	3.54	1031	3.69	1053	3.83	1076	3.97	1099	4.1	1123	4.23

150 BLOWER PERFORMANCE

Air Volume CFM	STATIC PRESSURE EXTERNAL – Inches Water Gauge																	
	0.2		0.3		0.4		0.5		0.6		0.7		0.8		0.9		1	
CFM	RPM	BHP	RPM	BHP	RPM	BHP	RPM	BHP	RPM	BHP	RPM	BHP	RPM	BHP	RPM	BHP	RPM	BHP
2600	511	0.54	541	0.62	573	0.69	607	0.77	644	0.85	681	0.94	718	1.03	752	1.11	785	1.19
2800	521	0.63	551	0.7	583	0.78	617	0.85	653	0.94	690	1.02	726	1.11	760	1.2	792	1.28
3000	532	0.72	562	0.79	594	0.87	628	0.94	664	1.03	700	1.12	735	1.21	768	1.3	800	1.38
3200	544	0.81	574	0.88	606	0.96	640	1.04	675	1.12	710	1.22	744	1.31	777	1.41	808	1.49
3400	556	0.9	586	0.98	618	1.06	652	1.14	687	1.23	721	1.33	754	1.43	786	1.52	816	1.61
3600	570	1.01	600	1.09	632	1.17	665	1.26	699	1.35	732	1.44	764	1.54	795	1.64	825	1.73
3800	585	1.12	615	1.21	647	1.29	679	1.38	712	1.47	744	1.56	775	1.66	806	1.76	835	1.86
4000	600	1.25	631	1.34	662	1.42	694	1.51	725	1.59	757	1.69	787	1.79	817	1.9	845	2
4200	617	1.38	647	1.47	678	1.55	709	1.64	739	1.73	769	1.82	799	1.93	828	2.04	856	2.15
4400	635	1.53	664	1.61	694	1.69	724	1.78	754	1.87	783	1.96	812	2.07	840	2.19	867	2.32
4600	653	1.68	682	1.76	711	1.84	740	1.92	768	2.01	797	2.11	825	2.23	852	2.36	879	2.51
4800	672	1.83	700	1.91	728	1.99	756	2.08	783	2.17	811	2.28	838	2.41	865	2.56	891	2.71
5000	691	1.99	719	2.07	745	2.16	772	2.25	799	2.36	826	2.48	852	2.62	879	2.77	904	2.94
5200	711	2.16	737	2.24	763	2.33	789	2.44	815	2.55	841	2.69	867	2.84	893	3.01	917	3.2
5400	731	2.34	756	2.43	781	2.53	806	2.64	832	2.78	857	2.93	882	3.09	907	3.28	931	3.47
5600	751	2.53	775	2.63	799	2.74	824	2.87	849	3.02	874	3.19	898	3.37	922	3.57	946	3.77
5800	770	2.74	794	2.85	818	2.98	842	3.13	866	3.29	891	3.47	915	3.68	938	3.89	961	4.1
6000	790	2.97	813	3.1	837	3.25	860	3.41	884	3.59	908	3.79	932	4.01	955	4.23	977	4.45

Air Volume CFM	STATIC PRESSURE EXTERNAL – Inches Water Gauge																			
	1.1		1.2		1.3		1.4		1.5		1.6		1.7		1.8		1.9		2	
CFM	RPM	BHP	RPM	BHP	RPM	BHP	RPM	BHP	RPM	BHP	RPM	BHP	RPM	BHP	RPM	BHP	RPM	BHP	RPM	BHP
2600	816	1.26	846	1.33	875	1.41	902	1.49	928	1.57	954	1.66	978	1.75	1003	1.83	1027	1.92	1051	2.01
2800	823	1.36	853	1.43	881	1.52	908	1.6	934	1.69	959	1.79	984	1.88	1008	1.97	1032	2.07	1056	2.16
3000	830	1.46	859	1.54	887	1.63	914	1.73	940	1.83	965	1.93	990	2.03	1014	2.13	1038	2.22	1062	2.32
3200	838	1.57	867	1.66	894	1.76	920	1.86	946	1.97	971	2.08	996	2.18	1020	2.29	1044	2.39	1068	2.49
3400	846	1.69	874	1.79	901	1.89	927	2	953	2.12	978	2.24	1002	2.35	1026	2.46	1050	2.57	1074	2.68
3600	854	1.82	882	1.92	909	2.04	935	2.16	960	2.29	984	2.41	1008	2.53	1032	2.65	1056	2.76	1080	2.87
3800	864	1.96	891	2.07	917	2.2	942	2.33	967	2.46	991	2.59	1015	2.72	1039	2.84	1062	2.96	1086	3.07
4000	873	2.11	900	2.24	925	2.37	950	2.51	975	2.65	998	2.79	1022	2.92	1045	3.04	1069	3.16	1092	3.28
4200	883	2.28	909	2.41	934	2.56	959	2.7	982	2.85	1006	2.99	1029	3.13	1052	3.25	1075	3.38	1099	3.5
4400	894	2.46	919	2.61	944	2.76	967	2.91	991	3.06	1014	3.21	1037	3.35	1059	3.48	1083	3.6	1106	3.73
4600	905	2.66	930	2.82	953	2.98	977	3.14	1000	3.29	1022	3.44	1045	3.58	1067	3.71	1090	3.84	1114	3.97
4800	916	2.88	941	3.05	964	3.22	987	3.38	1009	3.54	1031	3.69	1053	3.83	1076	3.97	1099	4.1	1123	4.23
5000	929	3.12	952	3.3	975	3.47	997	3.64	1019	3.8	1041	3.95	1063	4.1	1085	4.23	1108	4.37	1132	4.5
5200	941	3.38	964	3.57	987	3.75	1008	3.92	1030	4.08	1051	4.23	1073	4.38	1095	4.51	1118	4.65	1142	4.78
5400	955	3.67	977	3.86	999	4.04	1020	4.21	1041	4.37	1063	4.53	1084	4.67	1106	4.81	1129	4.94	1153	5.08
5600	969	3.97	990	4.17	1012	4.35	1033	4.52	1054	4.68	1074	4.84	1096	4.98	1117	5.11	1140	5.25	1165	5.38
5800	983	4.3	1005	4.5	1025	4.68	1046	4.85	1066	5.01	1087	5.16	1108	5.3	1130	5.43	1153	5.57	1177	5.7
6000	998	4.65	1019	4.84	1040	5.03	1060	5.2	1080	5.35	1100	5.5	1121	5.63	1143	5.76	1166	5.89	1190	6.03

180 BLOWER PERFORMANCE

Air Volume CFM	STATIC PRESSURE EXTERNAL – Inches Water Gauge																	
	0.2		0.3		0.4		0.5		0.6		0.7		0.8		0.9		1	
CFM	RPM	BHP	RPM	BHP	RPM	BHP	RPM	BHP	RPM	BHP	RPM	BHP	RPM	BHP	RPM	BHP	RPM	BHP
3200	421	0.48	471	0.62	521	0.74	573	0.85	624	0.96	663	1.11	692	1.28	724	1.44	756	1.57
3400	428	0.53	478	0.67	528	0.79	580	0.9	630	1.02	668	1.18	697	1.35	729	1.51	761	1.65
3600	436	0.58	485	0.72	535	0.85	587	0.96	636	1.08	673	1.25	701	1.42	733	1.59	766	1.73
3800	444	0.63	493	0.78	542	0.91	594	1.02	642	1.15	678	1.32	706	1.5	738	1.67	770	1.82
4000	452	0.69	501	0.84	550	0.97	601	1.08	648	1.22	683	1.39	711	1.58	743	1.75	775	1.9
4200	461	0.75	509	0.9	558	1.03	608	1.15	655	1.29	688	1.47	715	1.66	748	1.83	781	1.99
4400	470	0.82	518	0.96	566	1.1	616	1.22	662	1.36	694	1.55	720	1.75	753	1.92	786	2.08
4600	480	0.89	527	1.03	575	1.17	624	1.29	669	1.44	700	1.63	726	1.84	758	2.01	792	2.18
4800	490	0.96	537	1.11	584	1.24	633	1.37	676	1.52	706	1.72	731	1.93	764	2.11	798	2.27
5000	501	1.04	547	1.18	594	1.32	642	1.45	684	1.61	712	1.81	736	2.02	769	2.21	804	2.37
5200	512	1.13	557	1.26	604	1.4	651	1.53	692	1.7	719	1.91	742	2.13	775	2.31	810	2.48
5400	524	1.22	568	1.35	614	1.48	662	1.62	701	1.8	726	2.01	749	2.23	781	2.42	816	2.59
5600	536	1.31	580	1.44	625	1.58	672	1.72	710	1.9	734	2.12	755	2.35	788	2.54	823	2.71
5800	549	1.41	592	1.54	637	1.67	683	1.81	720	2	742	2.24	763	2.47	795	2.66	830	2.84
6000	562	1.52	605	1.64	650	1.77	695	1.92	730	2.11	750	2.36	770	2.61	802	2.8	837	2.98
6200	577	1.61	618	1.74	662	1.88	706	2.03	739	2.24	759	2.5	778	2.75	810	2.94	844	3.12
6400	592	1.71	632	1.85	675	2	717	2.17	748	2.39	767	2.65	787	2.9	819	3.09	852	3.27
6600	607	1.81	646	1.98	687	2.15	727	2.34	757	2.56	776	2.82	797	3.06	829	3.25	861	3.43
6800	622	1.93	659	2.12	697	2.32	736	2.53	764	2.75	785	3	807	3.23	838	3.41	870	3.59
7000	636	2.07	671	2.29	707	2.52	743	2.74	771	2.96	793	3.18	817	3.4	848	3.58	879	3.76
7200	649	2.25	682	2.49	716	2.74	750	2.97	778	3.18	802	3.38	828	3.58	858	3.76	889	3.93

Air Volume CFM	STATIC PRESSURE EXTERNAL – Inches Water Gauge																			
	1.1		1.2		1.3		1.4		1.5		1.6		1.7		1.8		1.9		2	
CFM	RPM	BHP	RPM	BHP	RPM	BHP	RPM	BHP	RPM	BHP	RPM	BHP	RPM	BHP	RPM	BHP	RPM	BHP	RPM	BHP
3200	789	1.7	822	1.82	856	1.93	888	2.06	918	2.2	947	2.34	976	2.49	1003	2.64	1029	2.8	1054	2.97
3400	794	1.78	827	1.9	860	2.02	892	2.15	922	2.29	951	2.43	979	2.59	1006	2.74	1032	2.91	1057	3.07
3600	799	1.86	832	1.99	864	2.11	896	2.24	926	2.38	954	2.53	982	2.69	1009	2.85	1035	3.01	1060	3.18
3800	803	1.95	836	2.08	869	2.2	900	2.34	930	2.48	958	2.64	985	2.79	1012	2.96	1038	3.12	1063	3.29
4000	808	2.04	841	2.17	874	2.3	905	2.44	934	2.59	962	2.74	989	2.9	1015	3.07	1040	3.23	1066	3.4
4200	814	2.13	847	2.26	879	2.4	909	2.54	938	2.69	965	2.85	992	3.02	1018	3.18	1043	3.35	1068	3.52
4400	820	2.23	853	2.36	884	2.5	914	2.65	942	2.8	969	2.97	995	3.14	1021	3.3	1046	3.47	1071	3.64
4600	826	2.32	858	2.46	890	2.61	919	2.76	947	2.92	973	3.09	999	3.26	1024	3.43	1049	3.6	1074	3.77
4800	832	2.42	865	2.57	895	2.72	924	2.87	951	3.04	977	3.21	1002	3.39	1027	3.56	1052	3.73	1077	3.89
5000	838	2.53	871	2.68	901	2.83	929	3	955	3.17	981	3.34	1006	3.52	1031	3.69	1056	3.86	1080	4.03
5200	844	2.64	877	2.8	907	2.96	934	3.12	960	3.3	985	3.47	1010	3.65	1034	3.82	1059	3.99	1084	4.16
5400	851	2.76	883	2.92	912	3.08	939	3.26	964	3.43	989	3.61	1014	3.79	1038	3.96	1063	4.13	1088	4.3
5600	857	2.88	889	3.05	918	3.22	944	3.39	969	3.58	993	3.75	1018	3.93	1043	4.11	1067	4.28	1092	4.45
5800	863	3.01	895	3.18	924	3.36	950	3.54	974	3.72	998	3.9	1023	4.08	1047	4.26	1072	4.44	1097	4.61
6000	870	3.15	901	3.32	929	3.5	955	3.69	979	3.87	1003	4.06	1028	4.24	1052	4.42	1077	4.6	1102	4.78
6200	877	3.3	908	3.47	935	3.65	961	3.84	984	4.04	1009	4.23	1033	4.41	1058	4.6	1083	4.78	1107	4.96
6400	885	3.45	914	3.62	942	3.81	967	4.01	990	4.21	1015	4.41	1039	4.6	1064	4.78	1088	4.97	1113	5.15
6600	892	3.6	921	3.78	948	3.98	973	4.18	996	4.39	1021	4.59	1045	4.79	1070	4.98	1095	5.16	1119	5.35
6800	900	3.76	929	3.95	954	4.15	979	4.37	1003	4.58	1027	4.79	1052	4.99	1076	5.18	1101	5.37	1126	5.55
7000	909	3.93	936	4.12	961	4.33	985	4.56	1009	4.78	1034	4.99	1058	5.19	1083	5.39	1108	5.57	1132	5.76
7200	917	4.11	943	4.31	968	4.53	992	4.75	1016	4.98	1040	5.2	1065	5.4	1090	5.6	1114	5.78	1139	5.97

240 BLOWER PERFORMANCE

Air Volume CFM	STATIC PRESSURE EXTERNAL – Inches Water Gauge																	
	0.2		0.3		0.4		0.5		0.6		0.7		0.8		0.9		1	
CFM	RPM	BHP	RPM	BHP	RPM	BHP	RPM	BHP	RPM	BHP	RPM	BHP	RPM	BHP	RPM	BHP	RPM	BHP
4200	483	0.82	532	0.96	581	1.08	630	1.21	674	1.36	705	1.56	731	1.75	763	1.93	796	2.08
4400	494	0.88	543	1.02	591	1.15	640	1.28	681	1.45	711	1.65	737	1.85	769	2.02	803	2.17
4600	506	0.95	554	1.09	601	1.22	649	1.36	689	1.54	717	1.74	743	1.94	775	2.12	809	2.27
4800	518	1.02	566	1.16	612	1.3	658	1.45	696	1.64	724	1.85	749	2.04	782	2.22	816	2.37
5000	531	1.1	578	1.24	623	1.38	668	1.55	704	1.75	730	1.96	756	2.14	789	2.32	823	2.48
5200	545	1.18	590	1.32	635	1.47	677	1.66	711	1.87	737	2.07	763	2.25	796	2.43	830	2.59
5400	559	1.27	603	1.41	646	1.58	686	1.78	719	2	744	2.2	770	2.37	803	2.55	837	2.71
5600	573	1.36	615	1.51	657	1.69	695	1.91	726	2.13	752	2.33	778	2.5	811	2.68	845	2.84
5800	587	1.47	628	1.62	668	1.81	705	2.04	735	2.27	760	2.46	787	2.63	819	2.81	853	2.98
6000	601	1.58	640	1.74	679	1.94	714	2.18	744	2.41	769	2.6	796	2.78	828	2.96	861	3.13
6200	615	1.69	653	1.87	690	2.09	724	2.33	752	2.56	778	2.75	805	2.92	837	3.11	870	3.28
6400	629	1.82	665	2.02	700	2.25	733	2.5	761	2.72	788	2.91	815	3.08	847	3.26	879	3.43
6600	643	1.96	676	2.19	710	2.43	742	2.68	771	2.9	798	3.08	826	3.24	857	3.42	889	3.59
6800	655	2.13	688	2.37	720	2.63	752	2.88	780	3.08	808	3.25	837	3.41	868	3.59	898	3.76
7000	667	2.32	699	2.58	730	2.84	761	3.08	790	3.27	819	3.43	849	3.59	879	3.76	908	3.94
7200	679	2.52	710	2.79	741	3.06	771	3.3	801	3.47	830	3.62	860	3.77	889	3.94	918	4.12
7400	691	2.75	721	3.02	752	3.29	782	3.52	812	3.67	842	3.81	871	3.96	900	4.13	927	4.32
7600	704	2.98	733	3.25	763	3.52	793	3.73	823	3.88	853	4	882	4.15	910	4.33	937	4.52
7800	716	3.21	745	3.48	775	3.74	805	3.94	835	4.08	864	4.2	893	4.35	920	4.53	946	4.73
8000	730	3.44	758	3.7	787	3.95	817	4.15	846	4.29	876	4.41	904	4.56	930	4.74	955	4.95
8200	743	3.68	771	3.93	800	4.16	829	4.36	858	4.49	887	4.62	914	4.78	940	4.96	965	5.17
8400	757	3.92	784	4.16	812	4.38	841	4.57	870	4.71	898	4.84	925	5	950	5.19	974	5.4
8600	770	4.16	798	4.39	825	4.61	854	4.79	882	4.93	910	5.06	936	5.22	960	5.42	983	5.63

Air Volume CFM	STATIC PRESSURE EXTERNAL – Inches Water Gauge																			
	1.1		1.2		1.3		1.4		1.5		1.6		1.7		1.8		1.9		2	
CFM	RPM	BHP	RPM	BHP	RPM	BHP	RPM	BHP	RPM	BHP	RPM	BHP	RPM	BHP	RPM	BHP	RPM	BHP	RPM	BHP
4200	829	2.21	862	2.33	893	2.46	923	2.61	950	2.76	977	2.93	1003	3.1	1029	3.26	1054	3.43	1079	3.6
4400	836	2.31	868	2.44	899	2.57	928	2.72	955	2.88	982	3.05	1008	3.22	1033	3.39	1058	3.56	1083	3.73
4600	843	2.41	875	2.54	906	2.69	934	2.84	960	3.01	986	3.18	1012	3.35	1037	3.52	1062	3.69	1087	3.86
4800	850	2.52	882	2.66	912	2.8	939	2.97	965	3.14	991	3.31	1016	3.48	1041	3.66	1066	3.82	1091	3.99
5000	857	2.63	889	2.77	918	2.93	945	3.1	970	3.27	995	3.45	1020	3.62	1045	3.79	1070	3.96	1095	4.13
5200	864	2.74	895	2.9	924	3.06	950	3.23	975	3.41	1000	3.59	1025	3.76	1050	3.93	1075	4.1	1099	4.27
5400	871	2.87	902	3.03	930	3.2	956	3.38	980	3.56	1005	3.73	1030	3.91	1055	4.08	1079	4.25	1104	4.42
5600	878	3	909	3.17	937	3.34	962	3.52	986	3.71	1011	3.89	1035	4.06	1060	4.24	1085	4.41	1110	4.58
5800	886	3.15	916	3.31	943	3.49	968	3.68	992	3.86	1016	4.05	1041	4.22	1066	4.4	1091	4.57	1115	4.75
6000	893	3.29	923	3.47	950	3.65	974	3.84	998	4.03	1023	4.22	1047	4.4	1072	4.58	1097	4.75	1122	4.93
6200	901	3.45	931	3.62	957	3.81	981	4.01	1005	4.21	1029	4.4	1054	4.58	1079	4.76	1103	4.94	1128	5.12
6400	910	3.6	938	3.79	964	3.99	988	4.19	1012	4.4	1036	4.59	1061	4.77	1086	4.96	1110	5.13	1135	5.32
6600	919	3.77	946	3.96	971	4.17	995	4.38	1019	4.59	1044	4.79	1068	4.98	1093	5.16	1117	5.34	1142	5.52
6800	927	3.94	954	4.15	979	4.36	1003	4.58	1027	4.8	1051	5	1076	5.19	1100	5.37	1125	5.55	1150	5.73
7000	936	4.13	962	4.34	986	4.56	1010	4.79	1034	5.01	1059	5.21	1084	5.4	1108	5.58	1132	5.76	1157	5.94
7200	945	4.32	970	4.54	994	4.77	1018	5	1042	5.22	1067	5.43	1091	5.62	1116	5.8	1140	5.98	1165	6.16
7400	953	4.52	978	4.75	1002	4.99	1026	5.22	1050	5.44	1075	5.65	1099	5.84	1124	6.02	1148	6.2	1172	6.38
7600	962	4.73	986	4.97	1010	5.21	1034	5.44	1058	5.66	1083	5.87	1107	6.06	1132	6.25	1156	6.43	1180	6.61
7800	970	4.95	994	5.19	1018	5.43	1042	5.67	1066	5.89	1091	6.1	1116	6.29	1140	6.48	1164	6.65	1188	6.84
8000	979	5.17	1002	5.41	1026	5.66	1050	5.9	1075	6.12	1099	6.33	1124	6.52	1148	6.71	1172	6.89	1196	7.07
8200	988	5.4	1011	5.64	1034	5.89	1058	6.13	1083	6.36	1108	6.56	1132	6.76	1156	6.94	1180	7.12	1204	7.3
8400	997	5.63	1019	5.88	1043	6.13	1067	6.37	1092	6.59	1116	6.8	1141	7	1165	7.18	1188	7.36	1212	7.54
8600	1006	5.87	1028	6.12	1051	6.37	1075	6.61	1100	6.84	1125	7.05	1149	7.24	1173	7.42	1197	7.6	1221	7.78

Repairing or Replacing Cabinet Insulation

⚠ IMPORTANT

DAMAGED INSULATION MUST BE REPAIRED OR REPLACED before the unit is put back into operation. Insulation loses its insulating value when wet, damaged, separated or torn.

Matte- or foil-faced insulation is installed in indoor equipment to provide a barrier between outside air conditions (surrounding ambient temperature and humidity) and the varying conditions inside the unit. If the insulation barrier is damaged (wet, ripped, torn or separated from the cabinet walls), the surrounding ambient air will affect the inside surface temperature of the cabinet. The temperature/humidity difference between the inside and outside of the cabinet can cause condensation on the inside or outside of the cabinet which leads to sheet metal corrosion and subsequently, component failure.

REPAIRING DAMAGED INSULATION

Areas of condensation on the cabinet surface are an indication that the insulation is in need of repair.

If the insulation in need of repair is otherwise in good condition, the insulation should be cut in an X pattern, peeled open, glued with an appropriate all-purpose glue and placed back against the cabinet surface, being careful to not overly compress the insulation so the insulation can retain its original thickness (see figure 23). If such repair is not possible, replace the insulation.

If using foil-faced insulation, any cut, tear, or separations in the insulation surface must be taped with a similar foil-faced tape.

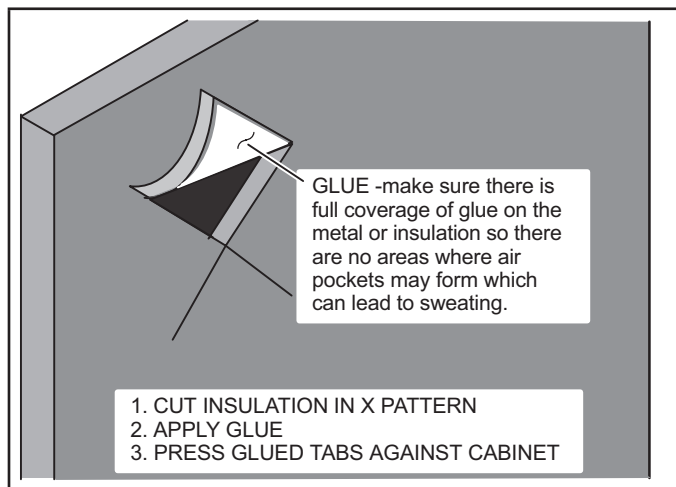

FIGURE 23. Repairing Insulation

Preventive Maintenance / Repair

IMPORTANT MAINTENANCE / REPAIR SAFETY INSTRUCTIONS

Prior to beginning work on systems containing **FLAMMABLE REFRIGERANTS**, safety checks are necessary to ensure that the risk of ignition is minimized.

Work shall be undertaken under a controlled procedure to minimize the risk of a flammable gas or vapor being present while the work is being performed.

All maintenance staff and others working in the local area shall be instructed on the nature of work being carried out. Work in confined spaces shall be avoided.

The area shall be checked with an appropriate refrigerant detector prior to and during work, to ensure the technician is aware of potentially toxic or flammable atmospheres. Ensure that the leak detection equipment being used is suitable for use with all applicable refrigerants, i.e. non-sparking, adequately sealed or intrinsically safe.

If any hot work is to be conducted on the refrigerating equipment or any associated parts, appropriate fire extinguishing equipment shall be available to hand. Have a dry powder or CO2 fire extinguisher adjacent to the charging area.

No person carrying out work in relation to a **REFRIGERATING SYSTEM** which involves exposing any pipe work shall use any sources of ignition in such a manner that it may lead to the risk of fire or explosion. All possible ignition sources, including cigarette smoking, should be kept sufficiently far away from the site of installation, repairing, removing and disposal, during which refrigerant can possibly be released to the surrounding space. Prior to work taking place, the area around the equipment is to be surveyed to make sure that there are no flammable hazards or ignition risks. "No Smoking" signs shall be displayed.

Where electrical components are being changed, they shall be fit for the purpose and to the correct specification. At all times, the manufacturer's maintenance and service guidelines shall be followed. If in doubt, consult the manufacturer's technical department for assistance.

The following checks shall be applied to installations using **FLAMMABLE REFRIGERANTS**:

- the actual **REFRIGERANT CHARGE** is in accordance with the room size within which the refrigerant containing parts are installed;
- the ventilation machinery and outlets are operating adequately and are not obstructed;
- if an indirect refrigerating circuit is being used, the secondary circuit shall be checked for the presence of refrigerant;
- marking to the equipment continues to be visible and legible. Markings and signs that are illegible shall be corrected;
- refrigerating pipe or components are installed in a position where they are unlikely to be exposed to any substance which may corrode refrigerant containing components, unless the components are constructed of materials which are inherently resistant to being corroded or are suitably protected against being so corroded.

Repair and maintenance to electrical components shall include initial safety checks and component inspection procedures. If a fault exists that could compromise safety, then no electrical supply shall be connected to the circuit until it is satisfactorily dealt with. If the fault cannot be corrected immediately but it is necessary to continue operation, an adequate temporary solution shall be used.

This shall be reported to the owner of the equipment so all parties are advised.

Initial safety checks shall include:

- that capacitors are discharged: this shall be done in a safe manner to avoid possibility of sparking;
- that no live electrical components and wiring are exposed while charging, recovering or purging the system;
- that there is continuity of earth bonding.

During repairs to sealed electrical components, the components shall be replaced. Replacement parts shall be in accordance with the manufacturer's specifications.

During repairs to intrinsically safe components, the components must be replaced. Replace components only with parts specified by the manufacturer. Other parts may result in the ignition of refrigerant in the atmosphere from a leak.

⚠ CAUTION

Before attempting to perform any service or maintenance, turn the electrical power to unit OFF at disconnect switch.

At the beginning of each heating and cooling season, the system should be checked as follows:

INDOOR UNIT

- 1 - Verify condensate drain line is unobstructed, freely flowing.
- 2 - Visually inspect the air handler coil; clean as needed, taking care not to overflow condensate drain.
- 3 - Visually inspect connecting lines and indoor coil for evidence of oil leaks.
- 4 - Visually inspect blower fan belt for excessive wear and verify proper belt tension. Replace or re-tension, as needed. Refer to Blower Motor Belt Tensioning Adjustment / Pulley Alignment sections for details.
- 5 - Check wiring for loose connections.
- 6 - Verify correct voltage at unit while operating, and measure amp draw of the indoor air handler.

Unit Nameplate _____ **Actual** _____

- 7 - Perform sensor maintenance (refer to Sensor Maintenance section for details).
- 8 - Review RDS for any trouble codes (See table 4). Take corrective action as required.
- 9 - Initiate Test of Mitigation system using RDS test button and verify proper system response. Refer to Refrigerant Leak Detection System section for details.

Sensor Maintenance

It is recommended to check the state of the sensor every 6 months, at the beginning of each cooling and heating season.

- Check that the sensor cable is in good condition.
- Ensure that the sensor opening is clear and free of debris.
 - o DO NOT use abrasive cleaning solutions or detergents to clean sensor opening.

- o DO NOT use flammable compressed air solutions to clean the sensor opening.
- o DO NOT vacuum sensor inlet opening, as this could cause damage to the sensor internal components.
- Replace sensor if the opening is not clean or free of debris.

NOTE – When cleaning the evaporator coil, remove the sensor from the coil. Recommended method is removal of bracket with sensor attached.



FIGURE 24. Example of Clear, Unobstructed Sensor Inlet

Decommissioning

Before carrying out this procedure, it is essential that the technician is completely familiar with the equipment and all its detail. It is recommended good practice that all refrigerants are recovered safely.

Prior to the task being carried out, an oil and refrigerant sample shall be taken in case analysis is required prior to re-use of recovered refrigerant. It is essential that electrical power is available before starting decommissioning.

- a) Become familiar with the equipment and its operation.
- b) Isolate system electrically.
- c) Before attempting the procedure, ensure that:
 - mechanical handling equipment is available, if required, for handling refrigerant cylinders;
 - all personal protective equipment is available and being used correctly;
 - the recovery process is supervised at all times by a competent person;
 - recovery equipment and cylinders conform to the appropriate standards.
- d) Pump down refrigerant system, if possible.
- e) If a vacuum is not possible, make a manifold so that refrigerant can be removed from various parts of the system.
- f) Make sure that cylinder is situated on the scales before recovery takes place.
- g) Start the recovery machine and operate in accordance with instructions.

- h) Do not overfill cylinders (no more than 80% volume liquid charge).
- i) Do not exceed the maximum working pressure of the cylinder, even temporarily.
- j) When the cylinders have been filled correctly and the process completed, make sure that the cylinders and the equipment are removed from site promptly and all isolation valves on the equipment are closed off.
- k) Recovered refrigerant shall not be charged into another REFRIGERATING SYSTEM unless it has been cleaned and checked.

 IMPORTANT
Equipment shall be labelled stating that it has been decommissioned and emptied of refrigerant. The label shall be signed and dated. Ensure that there are labels on the equipment that state the flammability of the refrigerant used.

Start-Up and Performance Checklist

Job Name _____	Job no. _____	Date _____
Job Location _____	City _____	State _____
Installer _____	City _____	State _____
Unit Model No. _____	Serial No. _____	Service Technician _____
Nameplate Voltage _____		
Rated Load Ampacity _____ Compressor Amperage: _____		
Maximum Fuse or Circuit Breaker _____		
Electrical Connections Tight? <input type="checkbox"/>	Indoor Filter clean? <input type="checkbox"/>	Supply Voltage (Unit Off) _____
Indoor Blower RPM _____	S.P. Drop Over Indoor (Dry) _____	Outdoor Coil Entering Air Temp. _____
Vapor Pressure; _____		
Refrigerant Lines: - Leak Checked? <input type="checkbox"/>	Properly Insulated? <input type="checkbox"/>	Outdoor Fan Checked? <input type="checkbox"/>
Service Valves: --- Fully Opened? <input type="checkbox"/>	Caps Tight? <input type="checkbox"/>	Voltage With Compressor Operating _____
SEQUENCE OF OPERATION		THERMOSTAT
Heating Correct? <input type="checkbox"/>	Cooling Correct? <input type="checkbox"/>	Calibrated? <input type="checkbox"/> Properly Set? <input type="checkbox"/> Level? <input type="checkbox"/>