



# INSTALLATION AND MAINTENANCE INSTRUCTIONS

\*RP16AC AND \*RP16HP SERIES UNITS

RESIDENTIAL PACKAGED UNITS  
Air Conditioners and Heat Pumps  
507635-05  
11/2022

THIS MANUAL MUST BE LEFT WITH THE HOMEOWNER FOR FUTURE REFERENCE

## Table of Contents

Unit Dimensions .....	2
Roof Curb Dimensions .....	4
Adjustable Roof Curb Dimensions.....	6
Installation .....	9
Electrical Wiring.....	11
Duct System .....	12
Condensate Drain.....	12
Sequence of Operation.....	14
Defrost System.....	15
System Performance .....	18
Maintenance .....	18
Wiring Diagrams.....	21

### **WARNING**

Installation and servicing of air conditioning equipment can be hazardous due to internal refrigerant pressure and live electrical components. Only trained and qualified service personnel should install or service this equipment. Installation and service performed by unqualified persons can result in property damage, personal injury, or death.

### **WARNING**

For your safety, do not store or use gasoline or other flammable vapors and liquids in the vicinity of this or any other appliance. Such actions could result in property damage, personal injury, or death.

See Unit Nameplate for Manufacturer



(P) 507635-05

### **CAUTION**

The installation of this appliance must conform to the requirements of the National Fire Protection Association; the National Electrical Code, ANSI/NFPA No. 70 (latest edition) in the United States; the Canadian Electrical Code Part 1, CSA 22.1 (latest edition) in Canada; and any state or provincial laws or local ordinances. Local authorities having jurisdiction should be consulted before installation is made. Such applicable regulations or requirements take precedence over the general instructions in this manual.

**Save these instructions for future reference**

# Unit Dimensions - Small Base Air Conditioners & Heat Pumps

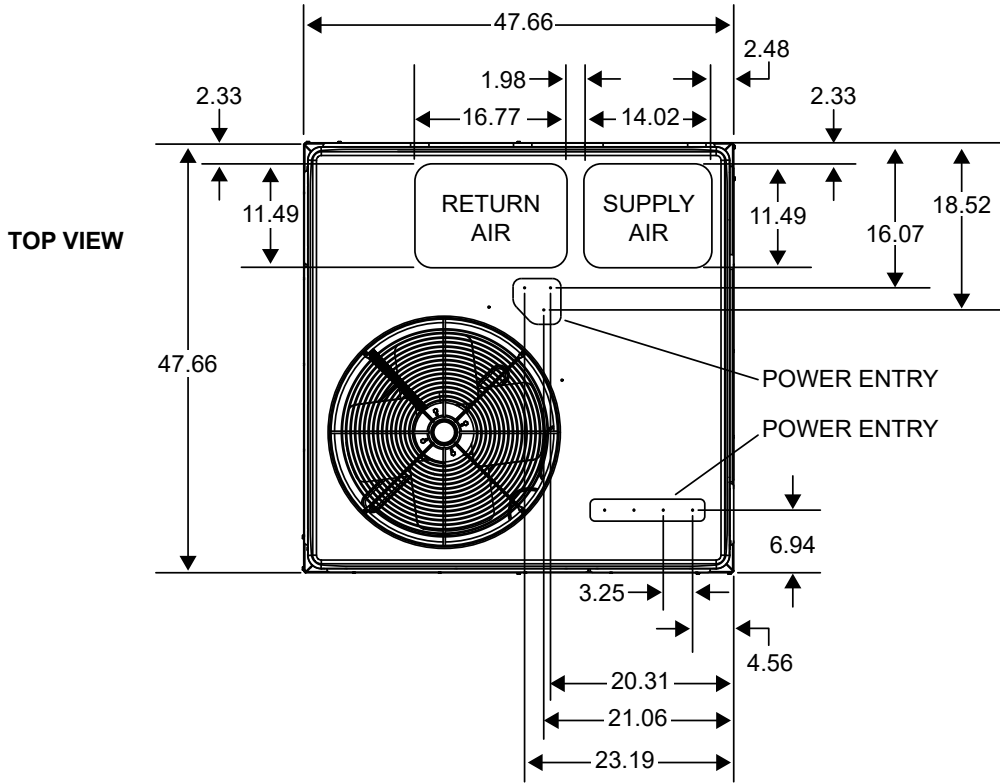

## SIDE VIEWS

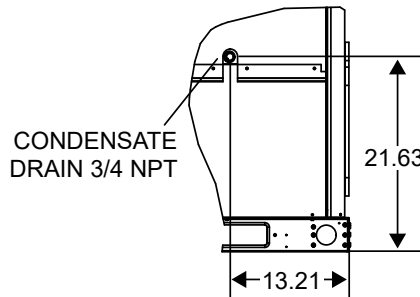
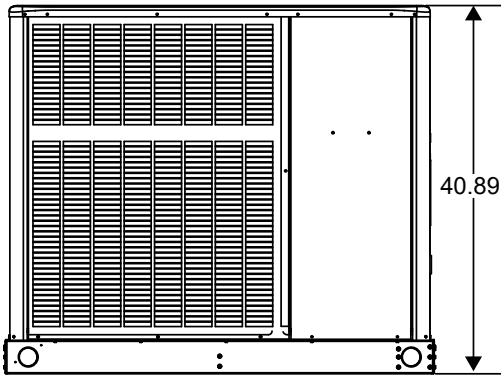

TYPICAL DRAIN LOCATION

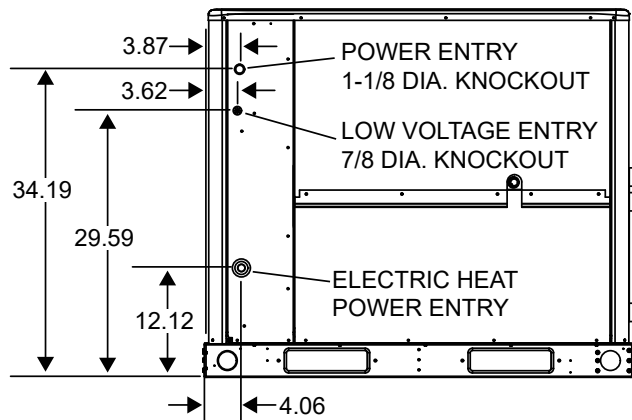
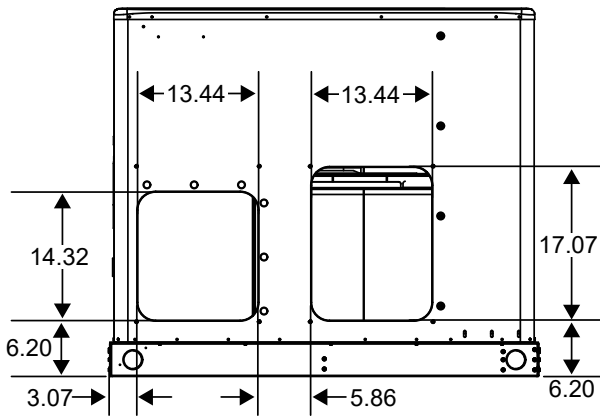

# Unit Dimensions - Large Base Air Conditioners & Heat Pumps

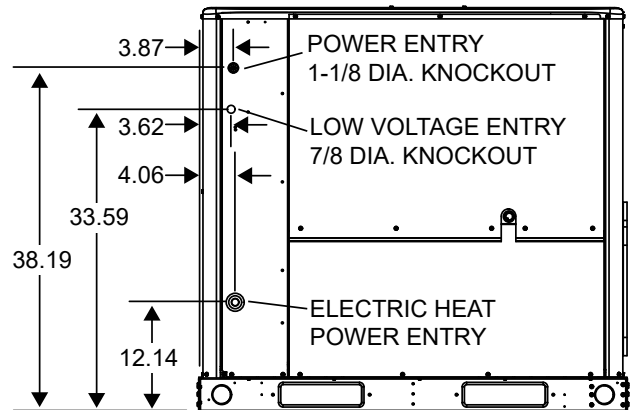
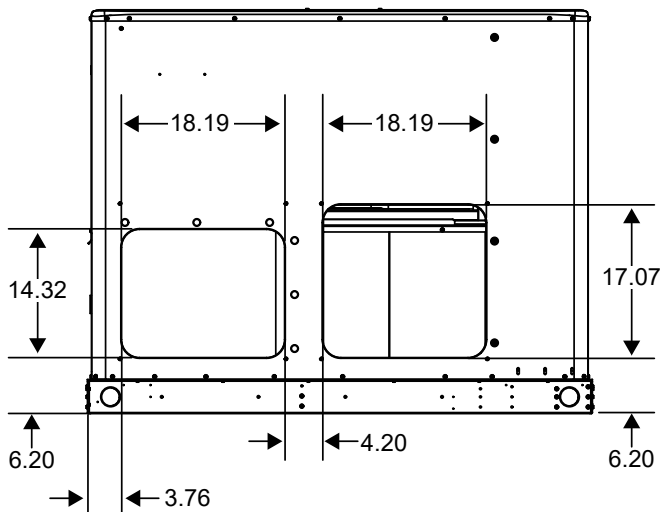
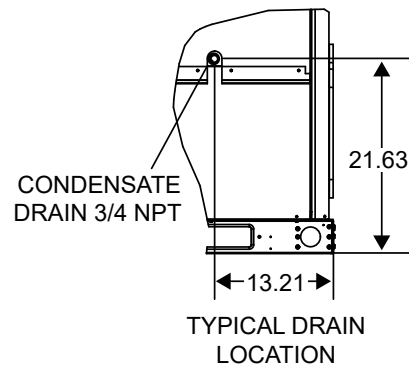
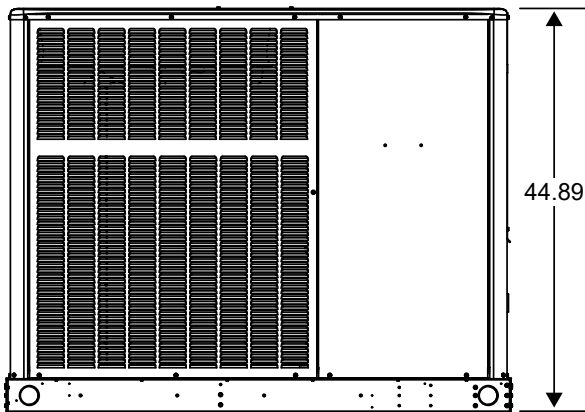
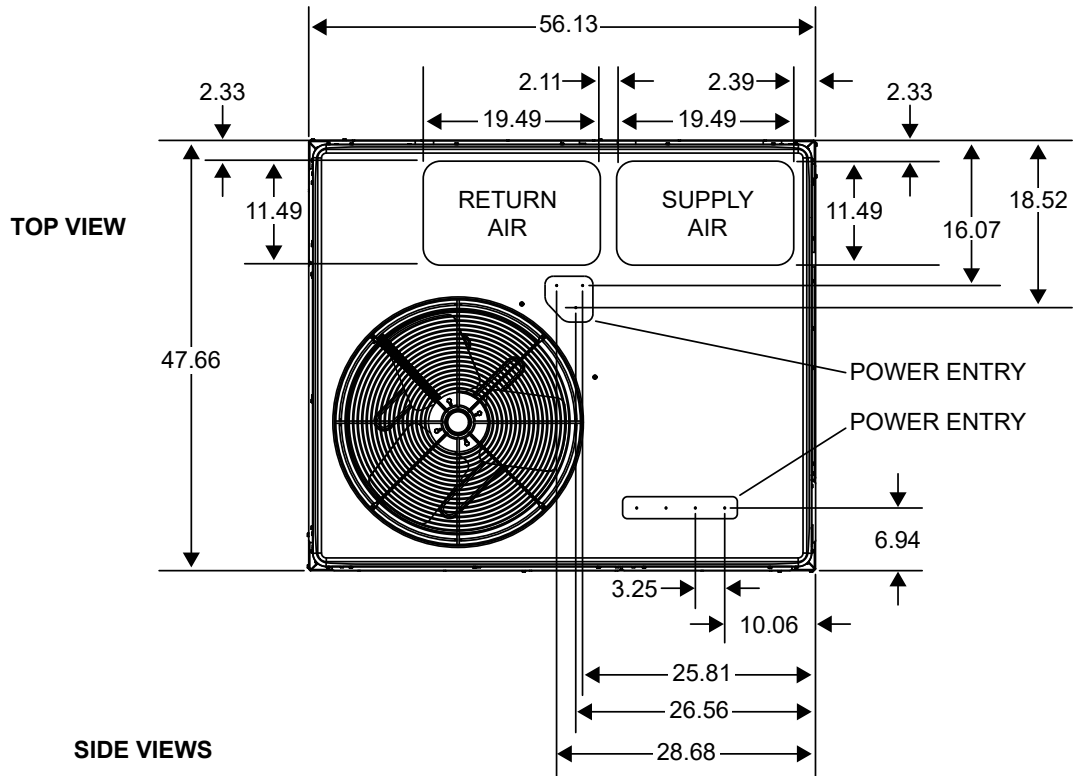

# Roof Curb Dimensions - Small Base Air Conditioners & Heat Pumps

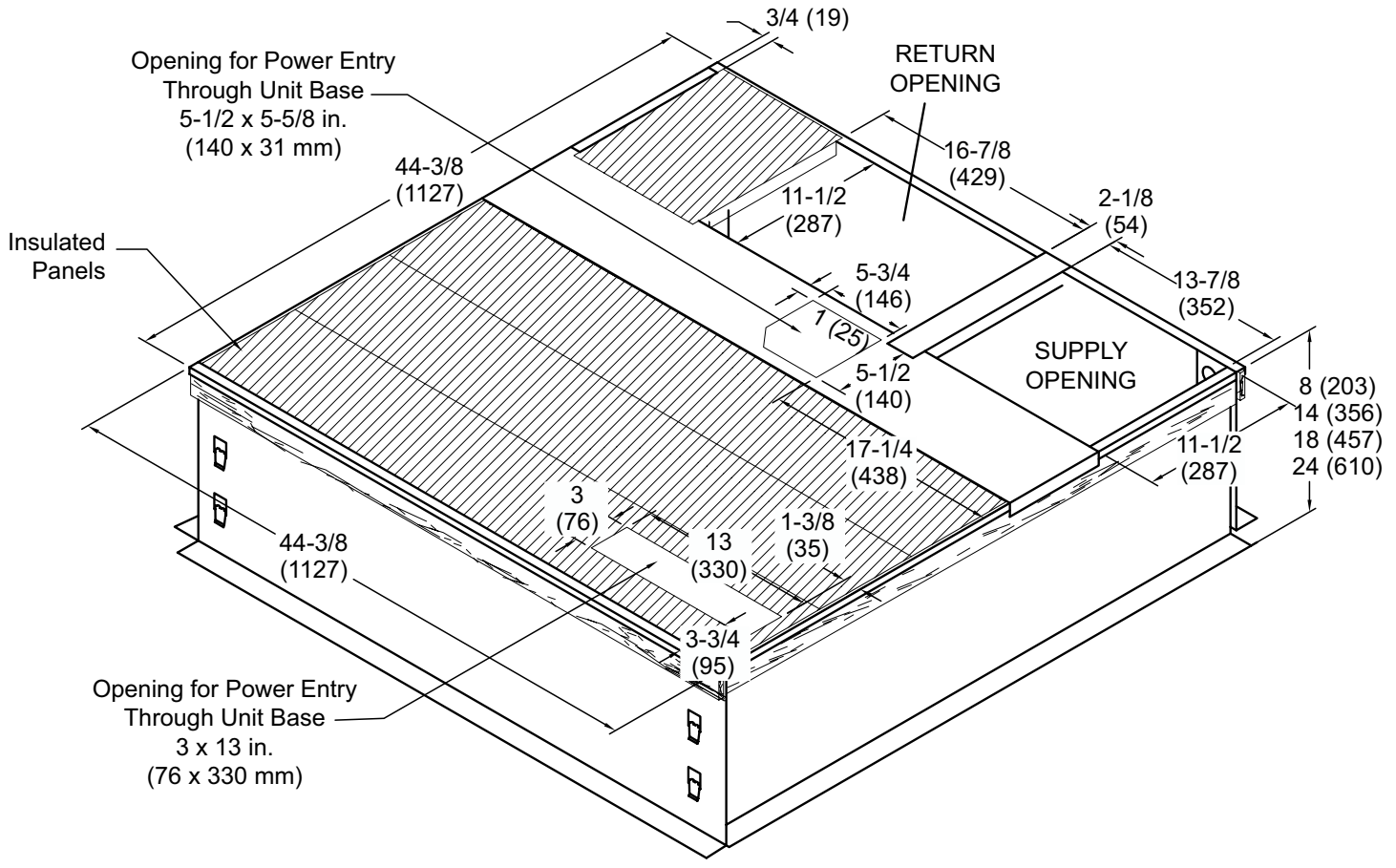

NOTE - Roof deck may be omitted within confines of curb.

# Roof Curb Dimensions - Large Base Air Conditioners & Heat Pumps

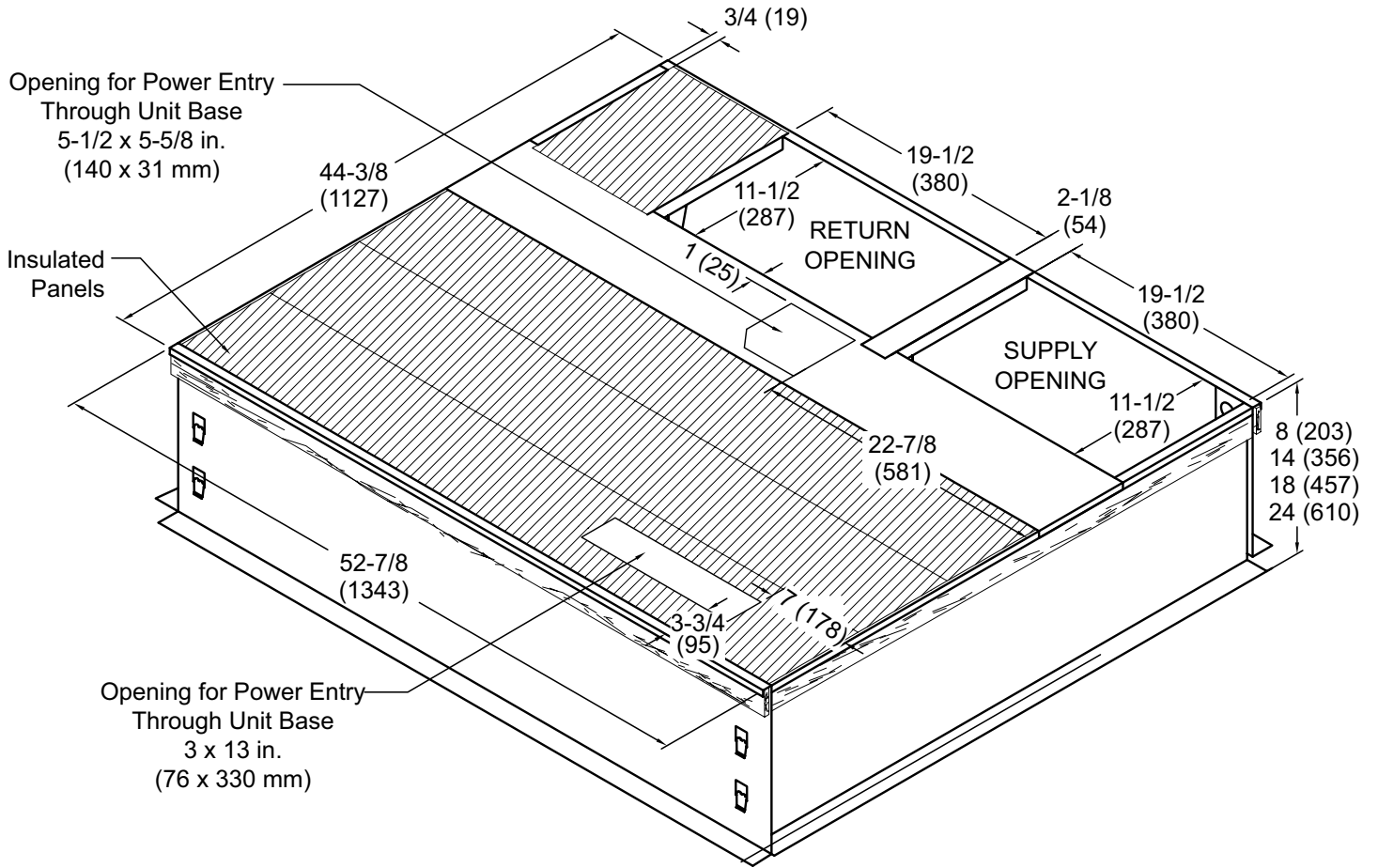

NOTE - Roof deck may be omitted within confines of curb.

# Adjustable Roof Curb Dimensions - Small Base Air Conditioners & Heat Pumps (Knock-Down Style)

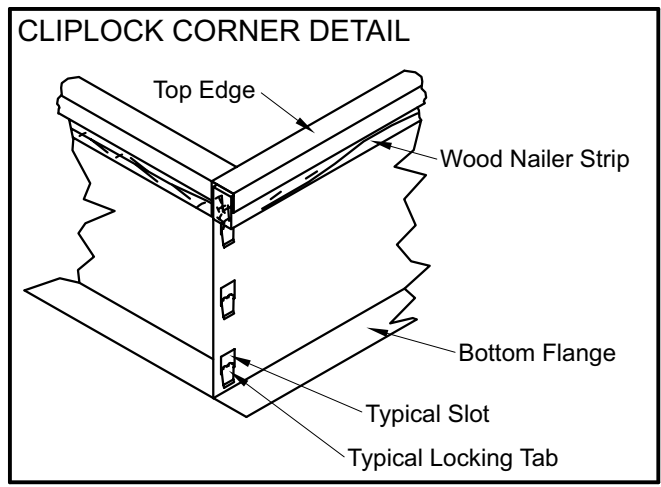

NOTE: See Cliplock 1000 installation instructions for complete assembly and installation procedures and requirements.

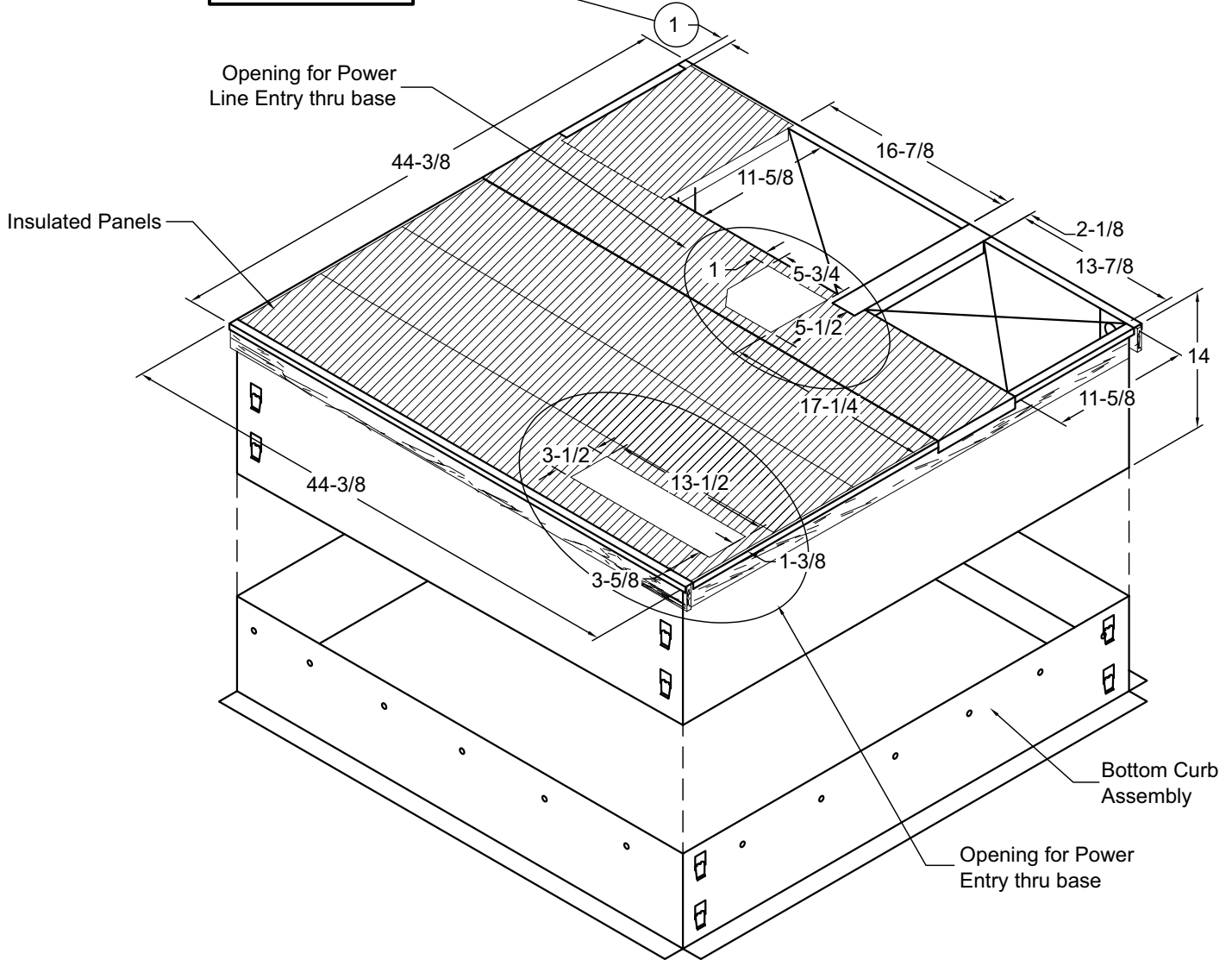
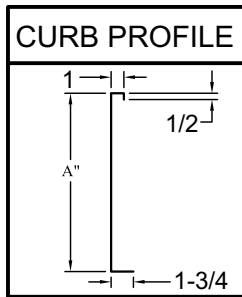

NOTE - Roof deck may be omitted within confines of curb.

# Adjustable Roof Curb Dimensions - Large Base Air Conditioners & Heat Pumps (Knock-Down Style)

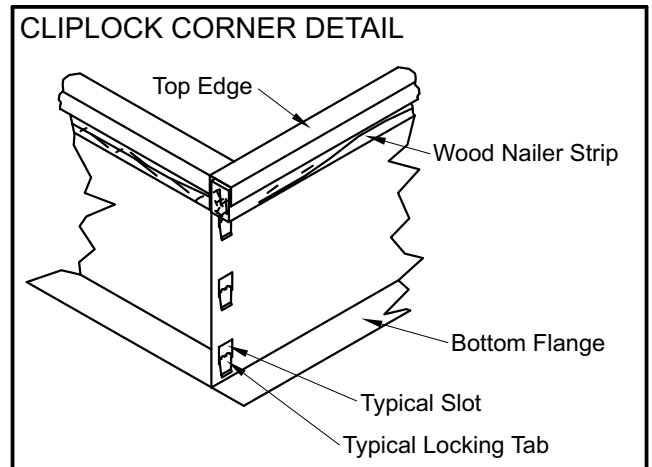

NOTE: See Cliplock 1000 installation instructions for complete assembly and installation procedures and requirements.

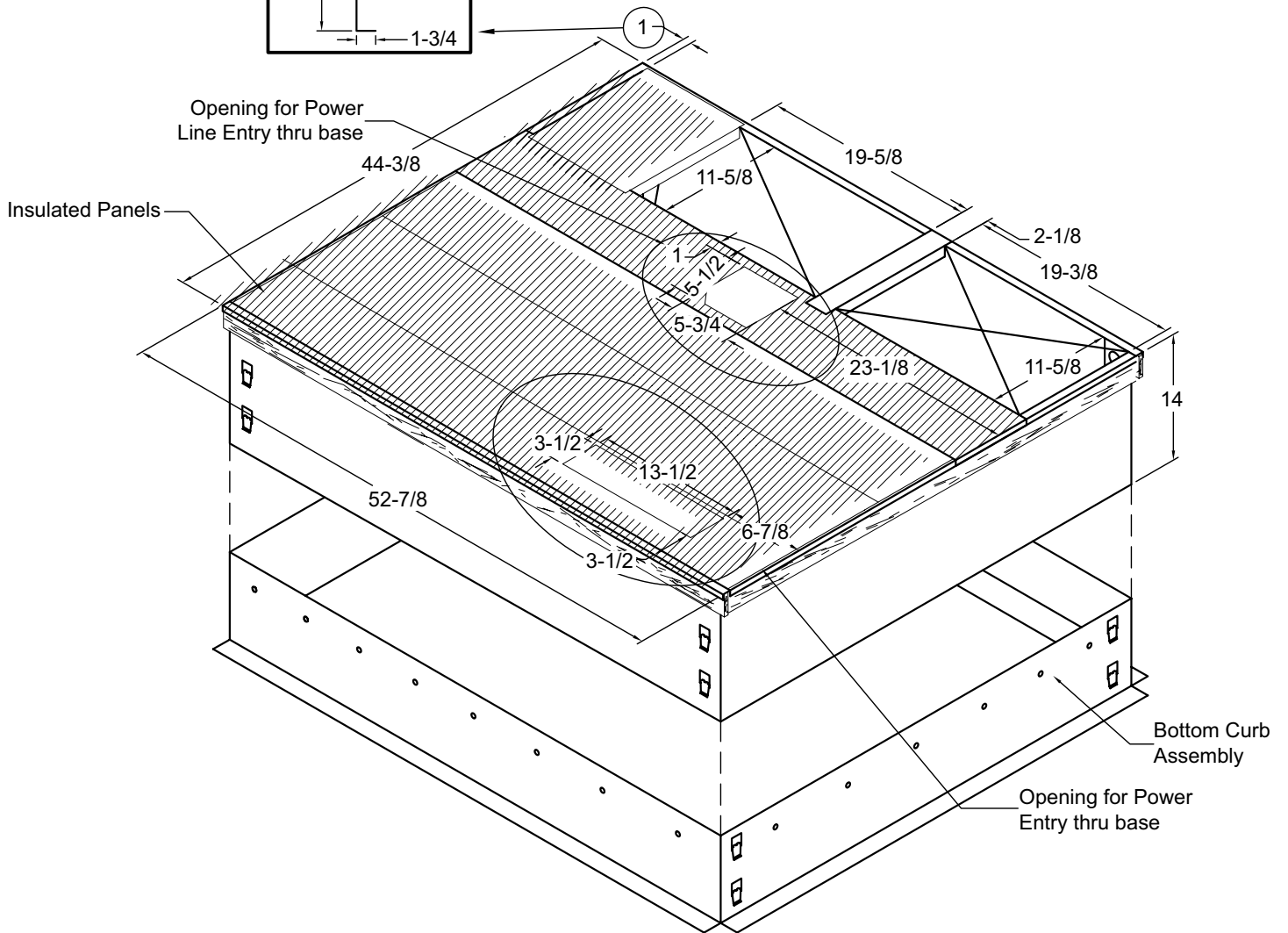
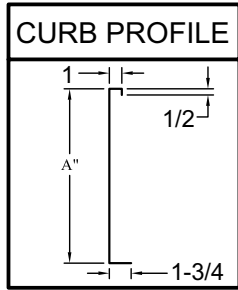

NOTE - Roof deck may be omitted within confines of curb.

# Adjustable Roof Curb Dimensions - Air Conditioners & Heat Pumps (Welded Style)

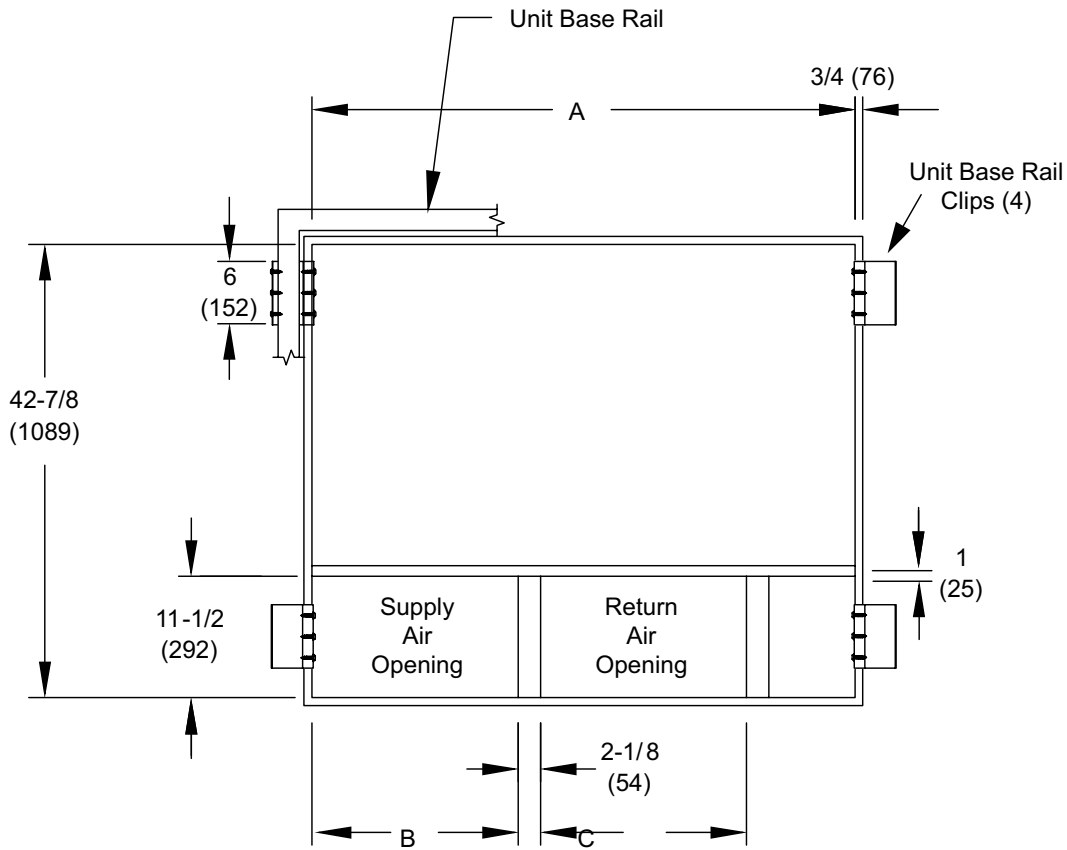
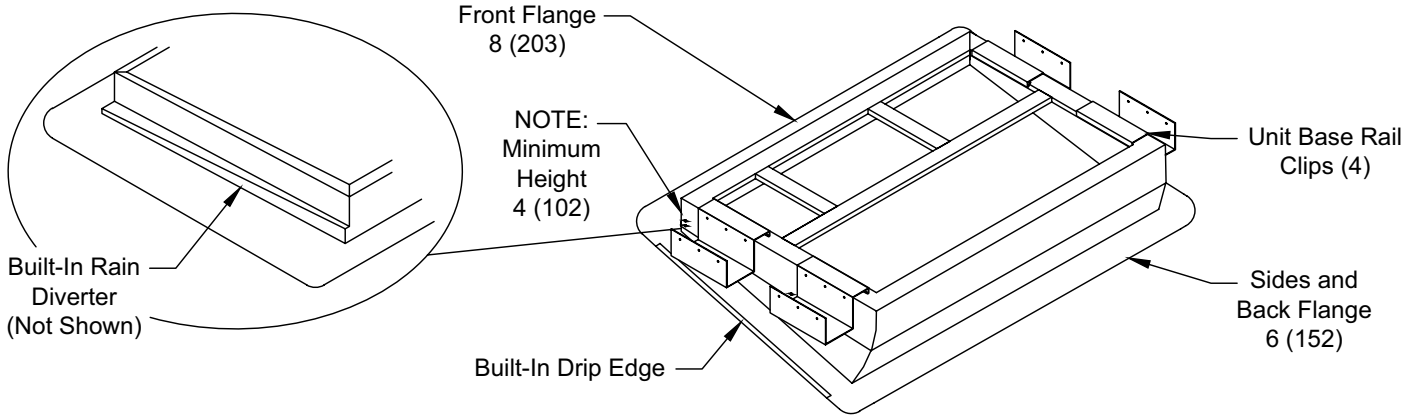

Usage	A		B		C	
	in.	mm	in.	mm	in.	mm
24,30,36	42-7/8	1089	13-7/8	352	16-7/8	429
42,48,60	51-3/8	1305	19-1/2	495	19-1/2	495



## **WARNING**

Improper installation, adjustment, alteration, service, or maintenance can cause injury or property damage. Refer to this manual. For assistance or additional information, consult a qualified installer or service agency.

## **Installation**

These instructions explain the recommended method of installation of the packaged heat pump and/or air conditioner units and associated electrical wiring.

This unit is designed and approved for use as a self-contained air-to-air outdoor heat pump and air conditioner system.

The units are factory-equipped with a transformer and blower control for applications without auxiliary heat. Electric heat accessory kits (PHK-) can be ordered for field installation of additional heat where required.

These instructions, and any instructions packaged with mating components and/or accessories, should be carefully read prior to beginning installation. Note particularly any **CAUTIONS** or **WARNINGS** in these instructions and all labels on the units.

These instructions are intended as a general guide only, for use by qualified personnel and do not supersede any national or local codes in any way. Compliance with all local, state, provincial, or national codes pertaining to this type of equipment should be determined prior to installation.

### **Inspection of Shipment**

Upon receipt of equipment, carefully inspect it for possible shipping damage. If damage is found, it should be noted on the carrier's freight bill. Take special care to examine the unit inside the carton if the carton is damaged. If damaged, file a claim with the transportation company.

If any damages are discovered and reported to the carrier, **DO NOT INSTALL THE UNIT, as claim may be denied.**

**Check the unit rating plate to confirm specifications are as ordered.**

### **Limitations**

The unit should be installed in accordance with all national and local safety codes.

Limitations of the unit and appropriate accessories must also be observed.

The unit must not be installed with any ductwork in the outdoor air stream. The outdoor fan is not designed to operate against any additional static pressure.

## **Location**

The unit is designed to be located outdoors with sufficient clearance for free entrance to the air inlet and discharge air openings. The location must also allow for adequate service access.

The unit must be installed on a solid foundation that will not settle or shift. Adequate structural support must be provided. Install the unit in level position. Isolate the base from the building structure to avoid possible transmission of sound or vibration into the conditioned space.

**The heat pump unit foundation should be raised to a minimum of 3" above finish grade.** In areas which have prolonged periods of temperature below freezing and snowfall, the heat pump unit should be elevated above the average snow line. Extra precaution should be taken to allow free drainage of condensate from defrost cycles to prevent ice accumulation. The unit should not be located near walkways, to prevent possible icing of surface from defrost condensate.

**Avoid placing the unit near quiet areas, such as sleeping quarters or study rooms.** Normal operating sound levels may be objectionable if the unit is placed near certain rooms.

**For improved start-up performance, the condenser coil should be washed with suitable detergent to remove any residue from manufacturing processes.**

## **Use of Unit During Construction**

Use of this unit as a construction heater or air conditioner is not recommended during any phase of construction. Very low return air temperatures, harmful vapors and operation of the unit with clogged or misplaced filters will damage the unit.

If this unit has been used for heating or cooling of buildings or structures under construction, the following conditions must be met or the warranty will be void:

- A room thermostat must control the unit. The use of fixed jumpers that will provide continuous heating or cooling is not allowed.
- A pre-filter must be installed at the entry to the return air duct.
- The return air duct must be provided and sealed to the unit.
- Return air temperature range between 55°F (13°C) and 80°F (27°C) must be maintained.
- Air filters must be replaced and pre-filters must be removed upon construction completion.
- The input rate and temperature rise must be set per the unit rating plate.
- The heat exchanger, components, duct system, air filters and evaporator coil must be thoroughly cleaned following final construction clean-up.

- The unit operating conditions (including airflow, cooling operation, ignition, input rate, temperature rise and venting) must be verified according to these installation instructions.

### Clearances

All units require certain clearances for proper operation and service. Refer to Table 1 for the minimum clearances to combustibles required for construction, servicing, and proper unit operation.

In the U.S., units may be installed on combustible floors made from wood or class A, B, or C roof covering material.

In Canada, units may be installed on combustible floors. Units must be installed outdoors.

**Do not permit overhanging structures or shrubs to obstruct condenser air discharge outlet.**

	Clearance to Combustibles	Clearance for Service Access
Front of unit	0 in.	24 in.
Back of unit	0 in.	0 in.
Left side	0 in.	24 in.
Right side	0 in.	24 in.
Base of unit	0 in.	0 in.
Top of unit	0 in.	48 in.

For any future service, installer must provide access to screws of top and rear panels.

**Table 1. Minimum Clearances**

### Compressor

Units are shipped with compressor mountings factory adjusted and ready for operation. Do not loosen compressor mounting bolts.

### Roof Curb Installation

If a roof curb is used, follow the manufacturer's installation instructions and be sure that all required clearances are observed (see Clearances section).

Prior to setting the unit on the roof curb, the shipping bracket located underneath the unit must be removed. Remove the two screws in the base rail (located on the front and rear sides of the unit). The four screws and the bracket can be discarded. See Figure 1.

### Rigging Unit

Exercise care when moving the unit. Do not remove any packaging until the unit is near the place of installation.

1. Connect rigging to the unit base rails using both holes in each corner.
2. All panels must be in place for rigging.
3. Place field-provided spreaders in place. Spreaders must be of adequate strength and length (must exceed unit dimension by 6 inches).

Units may also be moved or lifted with a forklift. **The lengths of the forks of the forklift must be a minimum of 42 inches.**

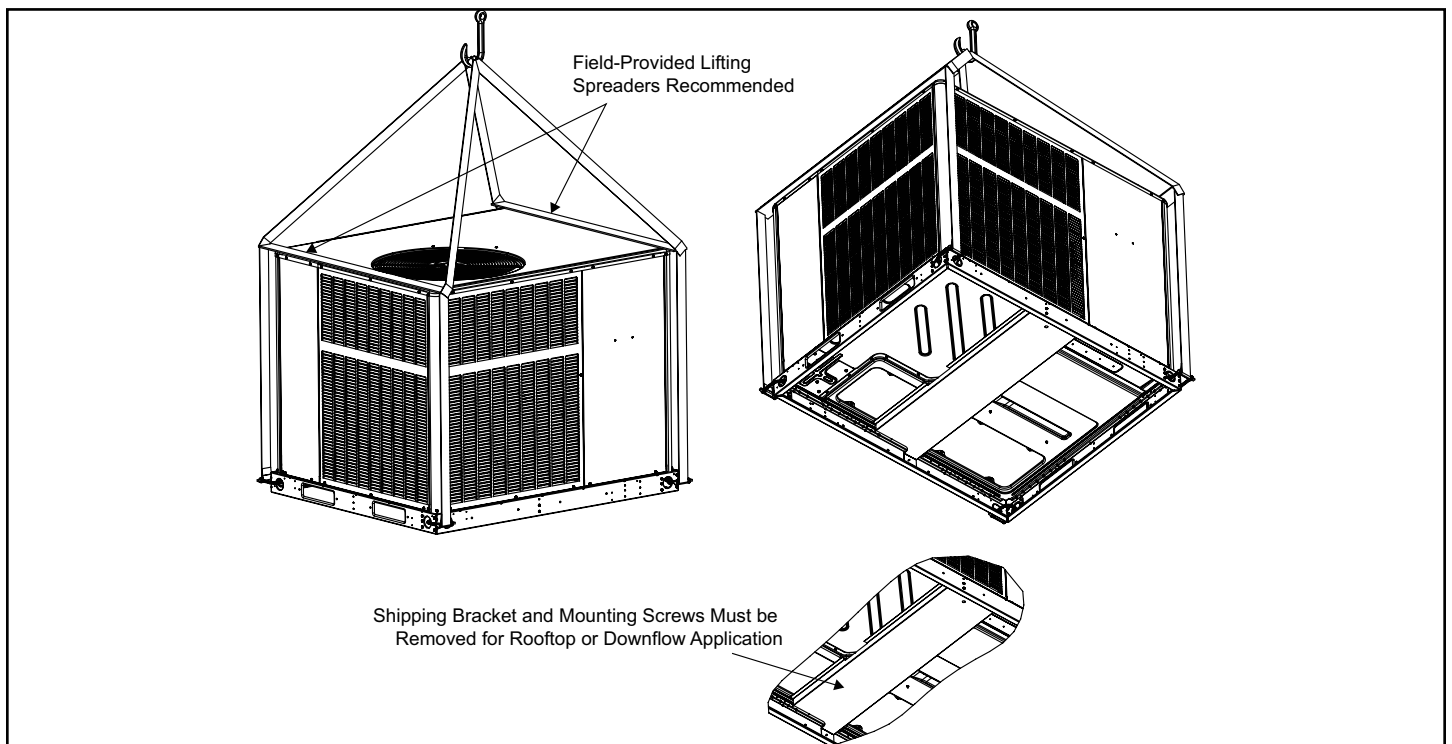

**Figure 1.**

## ⚠ CAUTION

Before lifting a unit, make sure that the weight is distributed equally on the cables so that it will lift evenly.

### Unpacking

Locate the four stacking brackets at each corner of the top panel. Remove the screws and washers that secure these brackets. All screws must be re-installed. The washers and stacking brackets can be discarded. Remove the bag and remaining packaging material, which can be discarded. Locate the four plastic fork slot bumpers on the base rails. Remove the fasteners and bumpers and discard.

## ⚠ CAUTION

As with any mechanical equipment, personal injury can result from contact with sharp sheet metal edges. Be careful when you handle this equipment.

### Service Access

Access to all serviceable components is provided by four removable panels: upper access panel (for blower, ID coil, and optional filter), Aux heat access, control access panel, and compressor access.

## ⚠ WARNING

This unit is charged with HFC-410A refrigerant. Operating pressures for units charged with HFC-410A are higher than pressures in units charged with HCFC-22. All service equipment **MUST** be rated for use with HFC-410A refrigerant.

## Electrical Wiring

All field wiring must be done in accordance with National Electrical Code recommendations, local codes, and applicable requirements of UL Standards, or in accordance with Canadian Electrical Code recommendations, local codes, or CSA Standards.

Power wiring, disconnect means, and over-current protection are to be supplied by the installer. Refer to the unit rating plate for maximum over-current protection and minimum circuit ampacity, as well as operating voltage. The power supply must be sized and protected according to specifications supplied.

The unit must be grounded with a separate ground conductor. See Figure 2 for typical field wiring connection. The wiring diagram can be found on the unit inside the access panel. Low voltage control wiring are terminal strip or pigtail leads located on the main control box and are

color-coded to match the connection called out on the wiring schematic.

**NOTE:** An optional bottom-entry power kit is available for these units. See the kit instructions for proper installation details.

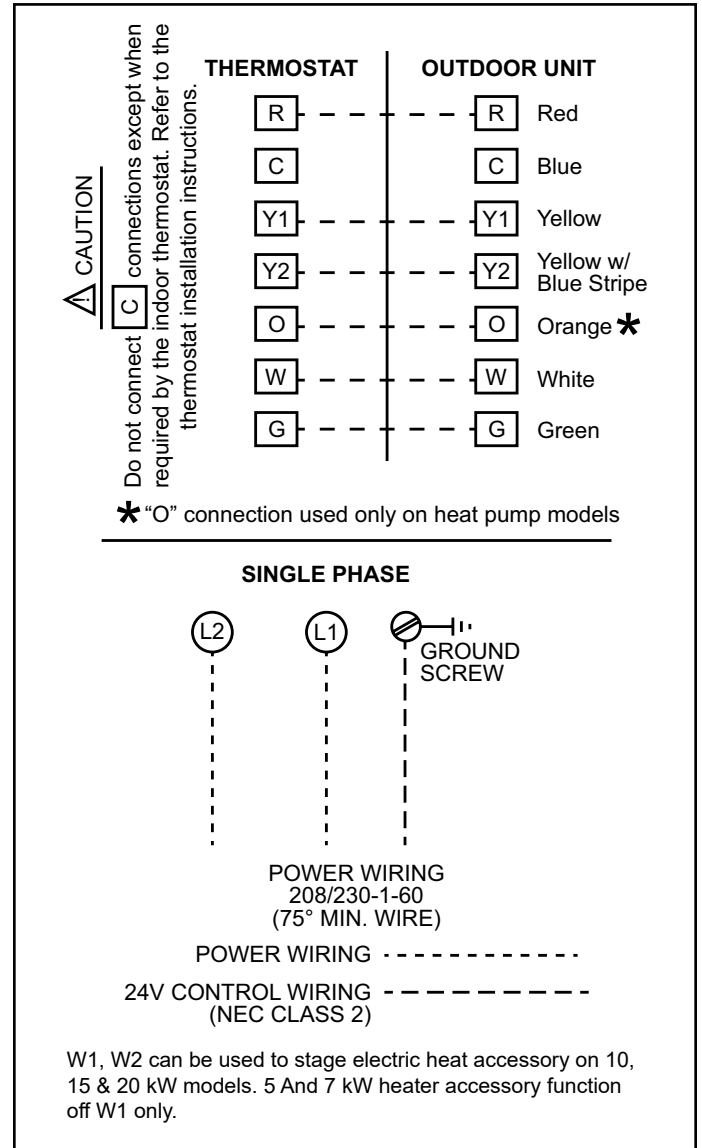

**Figure 2. Typical Wiring Connections**

## ⚠ CAUTION

When connecting electrical power and control wiring to the unit, waterproof-type connectors must be used so that water or moisture cannot be drawn into the unit during normal operation.

**Units are factory wired for a 230-volt power supply. If power supply is 208 volts, it will be necessary to change a wire connection on the unit transformer from 240V terminal to 208V terminal as shown on the wiring diagram.**

**Use only copper conductors.**

If any of the original unit wiring is replaced, the same size and type wire must be used.

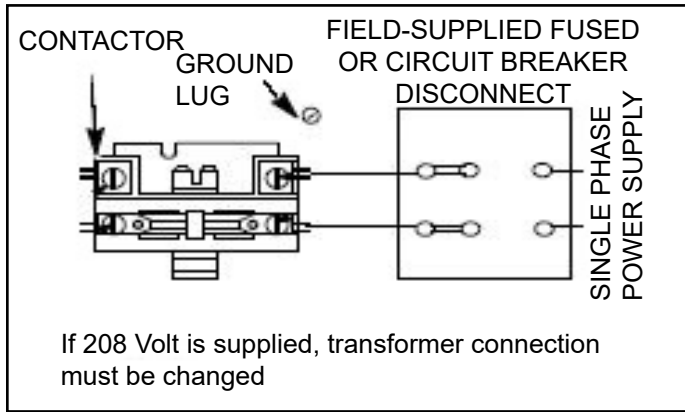

**Figure 3. 208 / 230 Line Voltage Wiring**

**Thermostat**

The room thermostat should be located on an inside wall where it will not be subject to drafts, sun exposure, or heat from electrical fixtures or appliances. Follow the manufacturer's instructions enclosed with the thermostat for general installation procedure. Color-coded insulated wires (#18 AWG) should be used to connect the thermostat to the unit. A minimum of five wires are required for proper installation.

**Duct System**

The duct system should be designed and sized according to the methods in the Air Conditioning Contractors of America (ACCA) manual that is most appropriate to the installation application.

A closed return duct system shall be used. This shall not preclude use of economizers or outdoor fresh air intake. It is recommended that supply and return duct connections at the unit be made with flexible joints.

The supply and return air duct systems should be designed for the CFM and static requirements of the job. They should not be sized to match the dimensions of the duct connections on the unit.

The unit is shipped ready for horizontal flow (side duct connections) or downflow (bottom duct connections). All units are equipped with a drain pan overflow switch that is installed and wired at the factory. Duct attachment screws are intended to go into the duct panel flanges. Duct to unit connections must be sealed and weather proofed.

For horizontal duct systems:

1. Remove the duct covers on side of the unit. They can be discarded.
2. Install the duct system to the unit.

For downflow duct systems:

1. Remove the duct covers on side of the unit. Keep the screws and the covers as they will be re-installed later.
2. Remove the downflow duct covers located inside unit. Remove the four screws securing each cover. Remove the covers from the unit. They can be discarded.
3. Remove screws located between the supply and return air openings that attach the blower deck to the base pan. These screws can interfere with bottom duct connections or roof curb seals. Discard these screws.
4. Install the duct system to the unit.
5. Re-install the duct covers removed in Step 1.

**Filters**

Air filters are not supplied with the unit. A field-provided air filter must always be installed ahead of the evaporator coil and must be kept clean or replaced. Dirty filters will reduce the airflow of the unit.

An optional filter rack kit may be purchased separately for installation inside the unit's coil compartment. Air filter sizes are shown in Table 2 for use with filter rack kit.

**NOTE:**

The filter rack must be installed prior to installation of the unit in applications where access to the rear panel is limited.

Unit Model	Filter 1	Filter 2
24,36	14 x 20 x 1	20 x 20 x 1
48,60	20 x 20 x 1	

**Table 2. Unit Air Filter Sizes - inches**

A Photocatalytic Oxidation (PCO) air purification system is available as a field-installed accessory for this product. A wiring harness for the installation of this accessory has been factory installed. If this accessory is going to be installed, it becomes critical that the system filter be installed ahead of this unit's return. Therefore, see the PCO accessory for filter requirements, plan the installation of filter ahead of this unit, and **do not use the internal filter rack described above.**

**Condensate Drain**

**CAUTION**

Drain lines should be hand-tightened only. Do not use tools to tighten fitting into drain.

This package unit is equipped with a 3/4" FPT coupling for condensate line connection. Plumbing must conform

to local codes. Use a sealing compound on male pipe threads.

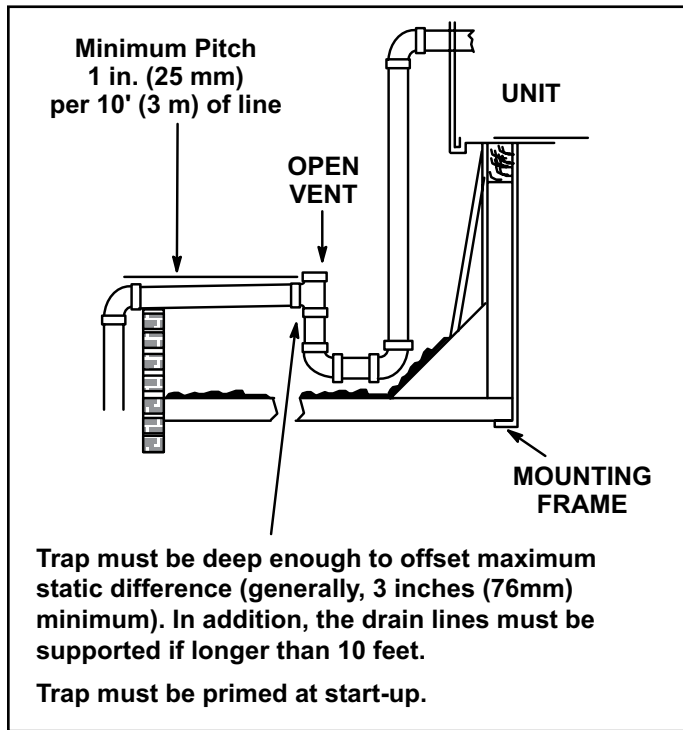

Figure 4. Typical Condensate Drain Connection

**Do not** operate unit without a drain trap. The condensate drain is on the negative pressure side of the blower; therefore, air being pulled through the condensate line will prevent positive drainage without a proper trap.

**The condensate drain line must be properly trapped, routed to a suitable drain and primed prior to unit commissioning.**

**NOTE:** Install drain lines and trap so they do not block service access to the unit.

See Figure 4 for proper drain arrangement. The drain line must pitch to an open drain or pump to prevent clogging of the line. Seal around the drain connection with suitable material to prevent air leakage into the return air system.

To prime trap, pour several quarts of water into drain, enough to fill drain trap and line.

### Crankcase Heater (if used)

Some models may be equipped with a crankcase heater to prevent excessive migration of liquid refrigerant into the compressor during off cycles. Power must be maintained to the unit to keep this feature active.

Except as required for safety while servicing, **do not open the system disconnect switch.**

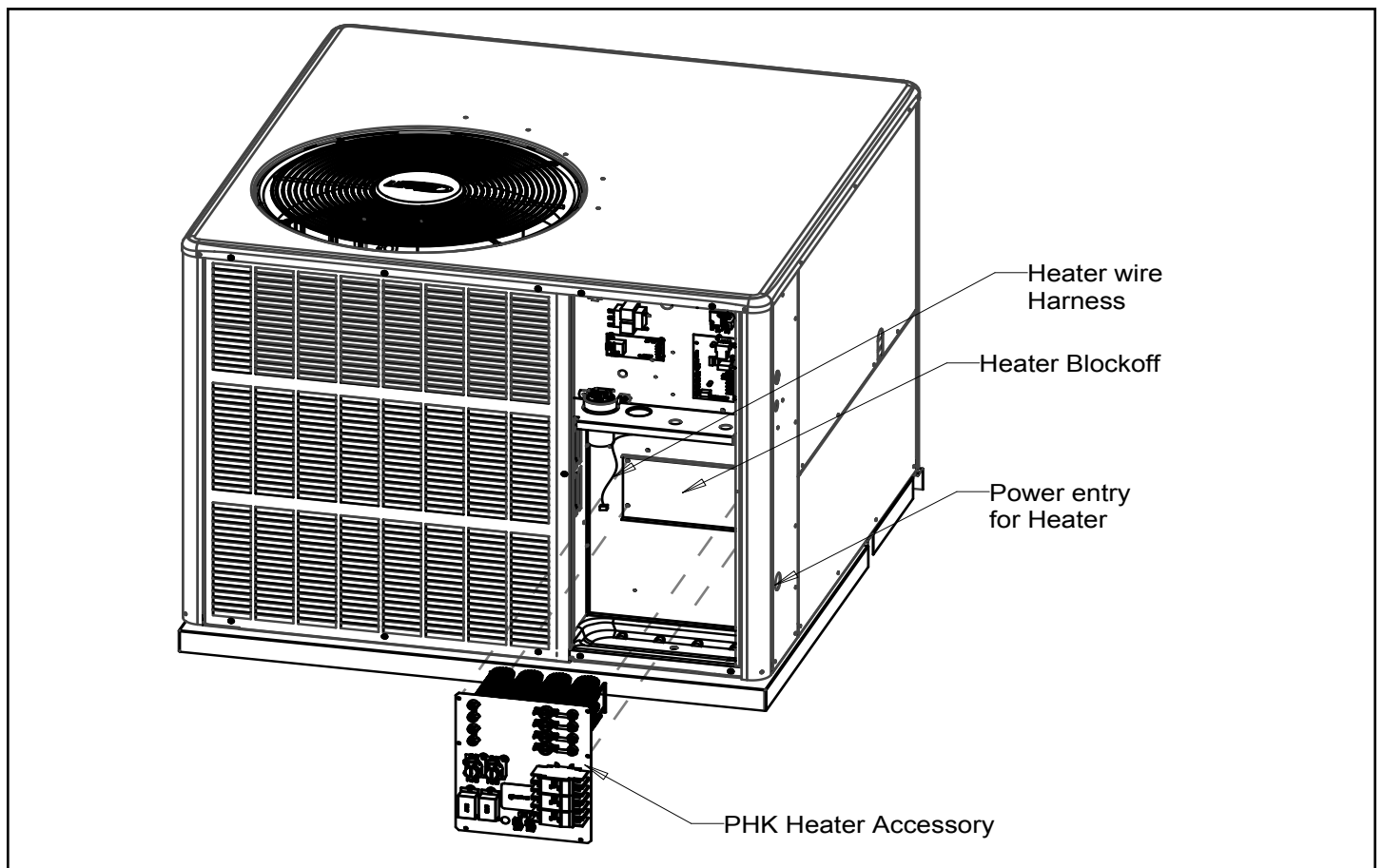

Figure 5.

### Heater Kit Accessory (if used)

The unit is fully equipped for operation without auxiliary heat. A heater kit accessory may also be used. To install the heater kit accessory (see Figure 5):

1. Disconnect the power and open the main control access.
2. Disconnect the plug separating the high voltage wire harness. Remove the high voltage wire harness plug and discard.
3. Remove the heater blockoff by removing the four screws holding it in place.
4. Insert the heater into the control panel and fasten in the same mounting holes.
5. Plug the heater wiring harness into the wire harness on the control assembly. Field wiring of the auxiliary heater is separate from the unit power supply. Wire the power supply wiring for the heater to the appropriate connections on the heater kit.

## Sequence of Operation

### Blower Control

Units are equipped with a variable speed motor that is capable of maintaining a specified CFM throughout the external static range. A particular CFM can be obtained by positioning jumpers (COOL, HEAT, and ADJUST) on the blower control. The HEAT and COOL jumpers are labeled A, B, C and D. Each of the numbers corresponds with an air volume (CFM) setting. The ADJUST jumper is labeled Test, -, +, and Norm. The + and - pin settings are used to add or subtract a percentage of the CFM selected. The Test jumper is used to operate the motor in the test mode. Figure 7 shows the blower control.

The **CFM LED** located on the blower control flashes one time per 100 cfm to indicate selected blower speed. For example, if the unit is operating at 1200 CFM, the CFM LED will flash 12 times. If the CFM is 1150, the CFM LED will flash 11 full times plus one fast or half flash. At times, the light may appear to flicker or glow. This takes

place when the control is communicating with the motor between cycles. This is normal operation. Read through the jumper settings section before adjusting the jumper to obtain the appropriate blower speed. To change jumper positions, gently pull the jumper off the pins and place it on the desired set of pins. The following section outlines the different jumper selections available and conditions associated with each one. Refer to Figure 7.

From the engineering handbook and/or specification sheet, determine which row most closely matches the desired CFM. Once a specific row has been chosen (+, NORMAL, or -), CFM volumes from other rows cannot be used. Below are descriptions of the jumper selections. The variable speed motor slowly ramps up to and down from the selected air flow during both cooling and heating demand. This minimizes noise and eliminates the initial blast of air when the blower is initially energized.

### ADJUST

The ADJUST pins allow the motor to run at normal speed, approximately 10 percent higher, or approximately 10 percent lower than normal speed.

The TEST pin is available to bypass the blower control and run the motor at approximately 70 percent to make sure that the motor is operational. This is used mainly in troubleshooting. The G terminal must be energized for the motor to run.

### COOL

The COOL jumper is used to determine the CFM during cooling operation. In AC units, this jumper selection is activated for cooling when Y1/Y2 is energized. In heat pump units, the selection is activated for cooling when Y1/Y2 and O are energized.

The blower motor runs at 80 percent of the selected air flow for the first 7-1/2 minutes of each cooling demand. This feature allows for greater humidity removal and saves energy.

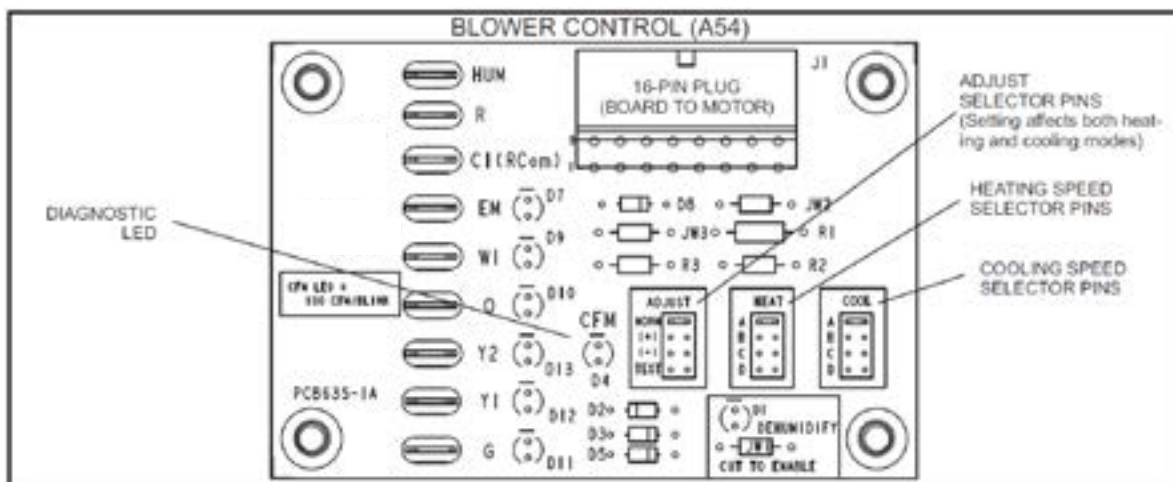

Figure 7.

In the cooling mode, the blower control delays blower operation for 5 seconds after the compressor starts. The blower continues to operate for 90 seconds after the compressor is de-energized. The delay is 5 minutes on the first start.

## HEAT

The HEAT jumper is used to determine CFM during electric heat operation only. These jumper selections are activated only when W1/W2 is energized.

## CONTINUOUS FAN

When the thermostat is set for "Continuous Fan" operation and there is no demand for heating or cooling, the blower control will provide 50 percent of the COOL CFM selected.

## DEHUMIDIFICATION

The blower control includes an HUM terminal, which provides for connection of a humidistat. The JV1 resistor on the blower control must be cut to activate the HUM terminal. The humidistat must be wired to open on humidity rise. When the dehumidification circuit is used, the variable speed motor will reduce the selected air flow rate by 25 percent when humidity levels are high. An LED (D1) lights when the blower is operating in the dehumidification mode.

## Cooling System

The cooling system is factory-charged with HFC-R-410A. The compressor is hermetically sealed and base-mounted with rubber-insulated bolts.

## Cooling

When the thermostat calls for cooling, R is closed to Y1 and O (see the wiring diagrams starting on Page 21). This action completes the low voltage control circuit, energizing the compressor, condenser fan motor, and blower motor. Second-stage cooling is initiated by the thermostat energizing Y2 in AC units and Y2 and O in heat pumps.

Unit compressors have internal protection. In the event there is an abnormal rise in the temperature of the compressor, the protector will open and cause the compressor to stop.

The thermostat automatically closes the R to G circuit, which brings on the indoor blower. Upon satisfying cooling demand, the thermostat will open the above circuits and open the main contactor, stopping the compressor and outdoor fan. If the unit is equipped with a delay timer, the blower will continue to operate for 60 to 90 seconds, which improves system efficiency.

## Heating - Heat Pump Stage

Upon heating demand, the thermostat closes circuit R to Y1, which closes the unit contactor, starting the compressor and outdoor fan. Second-stage heating is initiated when the thermostat energizes Y2, or when the outdoor ambient

temperature is below the lock-in temperature (see Second-Stage Lock-In section). The reversing valve is not energized in the heating mode. The thermostat again automatically brings on the indoor fan at the same time. Upon satisfying heating demand, the thermostat opens above circuits and stops unit operation.

**NOTE:** *O is de-energized in heating mode.*

## Heating - Auxiliary Electric Heat

Upon heating demand for auxiliary electric heat, the thermostat closes circuit R to W, which energizes the heater sequencers as well as the indoor blower. Upon satisfying auxiliary heat demand, the thermostat opens above circuits and heating elements sequence off; the blower continues to operate until all heating elements have turned off.

Auxiliary electric heat can be staged using W1, W2 on 10, 15 and 20 kW models. Staged wiring diagrams are included with the installation instructions of electric heater kits.

## Heating - Emergency Mode

When the thermostat calls for emergency heat, the R to W circuit is closed. Upon satisfying heat demand, the circuit is open and the blower continues to operate through an off delay period. The primary function of emergency mode is to provide emergency heat should the heat pump operation fail.

## Defrost System

### Defrost System

#### **Demand Defrost System**

The demand defrost system measures differential temperatures to detect when the system is performing poorly because of ice build-up on the outdoor coil. The system "self-calibrates" when the defrost system starts and after each system defrost cycle. The demand defrost components on the control board are listed below.

**NOTE:** *The demand defrost system accurately measures the performance of the system as frost accumulates on the outdoor coil. This typically will translate into longer running time between defrost cycles as more frost accumulates on the outdoor coil before the board initiates defrost cycles.*

#### **Defrost System Sensors**

Sensors connect to the defrost board through a field-replaceable harness assembly that plugs into the board. Through the sensors, the board detects outdoor ambient and coil fault conditions. As the detected temperature changes, the resistance across the sensor changes. Sensor resistance values can be checked by ohming across pins.

**NOTE:** *When checking the ohms across a sensor, be aware that a sensor showing a resistance value that is not*

within the range shown, may be performing as designed. However, if a shorted or open circuit is detected, then the sensor may be faulty and the sensor harness will need to be replaced.

Sensor	Temperature Range °F (°C)	Red LED (DS1)	Pins / Wire Color
Outdoor (ambient)	-35 (-37) to 120 (48)	280,000 to 3750	3 & 4 (black)
Coil	-35 (-37) to 120 (48)	280,000 to 3750	5 & 6 (brown)

**NOTE:** Sensor resistance decreases as sensed temperature increases.

**Table 3. Sensor Temp. / Resistance Range**

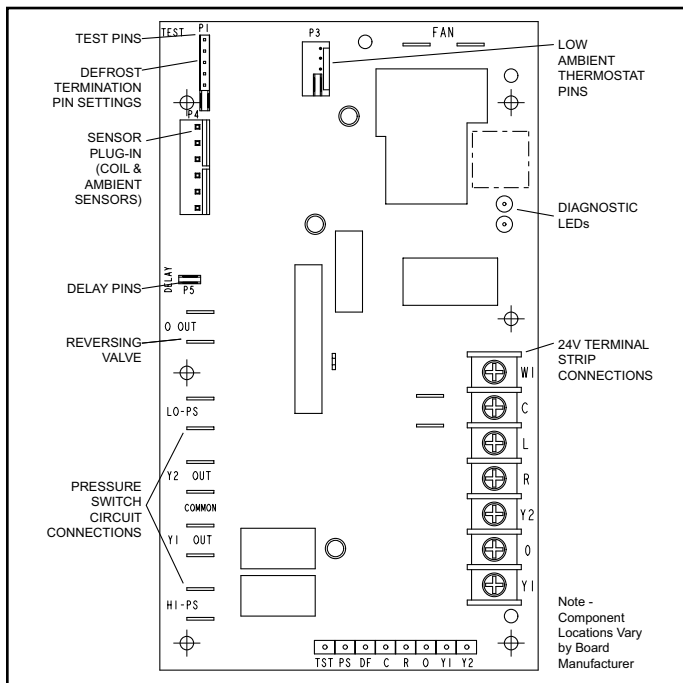

**Figure 6. Defrost Control Board (2-Ton Units)**

### Coil Sensor

The coil temperature sensor considers outdoor temperatures below -35°F (-37°C) or above 120°F (48°C) as a fault. If the coil temperature sensor is detected as being open, shorted or out of the temperature range of the sensor, the board will not perform demand or time/temperature defrost operation and will display the appropriate fault code. Heating and cooling operation will be allowed in this fault condition.

**NOTE:** The coil temperature probe is designed with a spring clip to allow mounting to the outside coil tubing. Coil sensor location is important for proper defrost operation.

### Ambient Sensor

The ambient sensor considers outdoor temperatures below -35°F (-37°C) or above 120°F (48°C) as a fault. If the ambient sensor is detected as being open, shorted or out of the temperature range of the sensor, the board will not perform demand defrost operation. The board will revert to time/temperature defrost operation and will display the appropriate fault code. Heating and cooling operation will be allowed in this fault condition.

**NOTE:** Within a single room thermostat demand, if 5-strikes occur, the board will lockout the unit. Control board 24 volt power "R" must be cycled "OFF" or the "TEST" pins on board must be shorted between 1 to 2 seconds to reset the board.

### Defrost Temperature Termination Shunt (Jumper) Pins

The defrost board selections are: 50, 70, 90, and 100°F (10, 21, 32 and 38°C). The shunt termination pin is factory set at 50°F (10°C). If the temperature shunt is not installed, the default termination temperature is 90°F (32°C).

### Delay Mode

The defrost system has a field-selectable function to reduce occasional sounds that may occur while the unit is cycling in and out of the defrost mode. When a jumper is installed on the DELAY pins, the compressor will be cycled off for 30 seconds going in and out of the defrost mode. Units are shipped with jumper installed on DELAY pins.

**NOTE:** The 30 second compressor delay feature (known as the quiet shift) **must** be deactivated during any unit performance testing. The feature is deactivated by removing the jumper located on the compressor delay pins on the control board mounted inside the unit control box. This feature is optional for the homeowner, but may impact testing performance.

### Defrost Operation

The defrost control system has three basic operational modes: normal, calibration, and defrost.

- **Normal Mode**—The demand defrost system monitors the O line, to determine the system operating mode (heat/cool), outdoor ambient temperature, coil temperature (outdoor coil) and compressor run time to determine when a defrost cycle is required.
- **Calibration Mode**—The board is considered uncalibrated when power is applied to the board, after cool mode operation, or if the coil temperature exceeds the termination temperature when it is in heat mode.

Calibration of the board occurs after a defrost cycle to ensure that there is no ice on the coil. During calibration, the temperature of both the coil and the ambient sensor are measured to establish the temperature differential which is required to allow a defrost cycle.



- **Defrost Mode**—The following paragraphs provide a detailed description of the defrost system operation.

### **Defrost Cycles**

The control board initiates a defrost cycle based on either frost detection or time.

- **Frost Detection**—If the compressor runs longer than 30 minutes and the actual difference between the clear coil and frosted coil temperatures exceeds the maximum difference allowed by the control, a defrost cycle will be initiated.

**IMPORTANT** - *The control board will allow a greater accumulation of frost and will initiate fewer defrost cycles than a time/ temperature defrost system.*

- **Time**—If 6 hours of heating mode compressor run time has elapsed since the last defrost cycle while the coil temperature remains below 35°F (2°C), the control board will initiate a defrost cycle.

### **Actuation**

When the reversing valve is de-energized, the Y1 circuit is energized, and the coil temperature is below 35°F (2°C), the board logs the compressor run time. If the board is not calibrated, a defrost cycle will be initiated after 30 minutes of heating mode compressor run time. The control will attempt to self-calibrate after this (and all other) defrost cycle(s).

Calibration success depends on stable system temperatures during the 20-minute calibration period. If the board fails to calibrate, another defrost cycle will be initiated after 45 minutes of heating mode compressor run time. Once the control board is calibrated, it initiates a demand defrost cycle when the difference between the clear coil and frosted coil temperatures exceeds the maximum difference allowed by the control OR after 6 hours of heating mode compressor run time has been logged since the last defrost cycle.

**NOTE:** *If ambient or coil fault is detected, the board will not execute the “TEST” mode.*

### **Termination**

The defrost cycle ends when the coil temperature exceeds the termination temperature or after 14 minutes of defrost operation. If the defrost is terminated by the 14-minute timer, another defrost cycle will be initiated after 30 minutes of run time.

### **5-Strike Lockout Feature**

The internal control logic of the board counts the pressure switch trips only while the Y1 (Input) line is active. If a pressure switch opens and closes four times during a Y1 (Input), the control logic will reset the pressure switch trip counter to zero at the end of the Y1 (Input). If the pressure switch opens for a fifth time during the current Y1 (Input), the control will enter a lockout condition.

The 5-strike pressure switch lockout condition can be reset by cycling OFF the 24-volt power to the control board or by shorting the TEST pins between 1 and 2 seconds. All timer functions (run times) will also be reset.

If a pressure switch opens while the Y1 Out line is engaged, a 5-minute short cycle will occur after the switch closes.

## Diagnostic LEDs

The defrost board uses two LEDs for diagnostics. The LEDs flash a specific sequence according to the condition as shown in Table 4.

Defrost Board Diagnostic LEDs		
Green LED (DS2)	Red LED (DS1)	Condition
OFF	OFF	No Power to Control
Simultaneous Slow FLASH		Normal Operation / Power to Control
Alternating Slow FLASH		5-min Anti-Short-Cycle Delay
ON	Slow FLASH	Low Pressure Switch Ignored (Low Ambient)
Fault & Lockout Codes		
OFF	Slow FLASH	Low Pressure Switch Fault
OFF	ON	Low Pressure Switch Lockout
Slow FLASH	OFF	High Pressure Switch Fault
ON	OFF	High Pressure Switch Lockout

**Table 4. Defrost Control (CMC1) Diagnostic LEDs**

## System Performance

This equipment is a self-contained, factory optimized refrigerant system, and should not require adjustments to system charge when properly installed. If unit performance is questioned, perform the following checks.

Ensure unit is installed per manufacturer's instructions and that line voltage and air flow is correct. Refer to Table 5 through Table 7 for proper performance value. The indoor metering device varies by model.

If the measured performance value varies from table value allowance, check internal seals, service panels and duct work for air leaks, as well as restrictions and blower speed settings. If unit performance remains questionable, remove system charge, evacuate to 500 microns, and weigh in refrigerant to nameplate charge. It is critical that the exact charge is re-installed. Failure to comply will compromise system performance.

If unit performance is still questionable, check for refrigerant-related problems, such as blocked coil or circuits, malfunctioning metering device or other system components.

## Maintenance

### WARNING

Before performing maintenance operations on the system, shut off all electrical power to the unit. Turn off accessory heater power switch if applicable. Electrical shock could cause personal injury or death.

Periodic inspection and maintenance normally consists of changing or cleaning the filters and cleaning the evaporator coil. On occasion, other components may also require cleaning.

### Filters

Filters are not supplied with the unit. Inspect once a month. Replace disposable or clean permanent type as necessary. Do not replace permanent type with disposable.

### Motors

Indoor and outdoor fan and vent motors are permanently lubricated and require no maintenance.

Some models may be equipped with a permanent magnet, constant torque indoor blower motor. These motors remain energized and are controlled by 24V signals. For high static applications, use tap 3 for cooling speed and tap 5 for heating speed. Refer to the heater installation label for limitations to blower tap selection on heating speeds.

### Evaporator Coil

Dirt and debris should not be allowed to accumulate on the evaporator coil surface or other parts in the air circuit. Cleaning should be as often as necessary to keep coil clean. Use a brush, vacuum cleaner attachment, or other suitable means. If water is used to clean the coil, be sure the power to unit is shut off prior to cleaning. **Care should be used when cleaning the coil so that the coil fins are not damaged.**

**Do not permit the hot condenser air discharge to be obstructed by overhanging structures or shrubs.**

### Condenser Coil

Clean condenser coil annually with water and inspect monthly during the cooling season.

Condenser coil may need to be cleaned at startup in case oil from the manufacturing process is found on the condenser coil.

**Table 5. Cooling Performance - AC Models**

80 DB / 67 WB Deg. Return Air		Air Temperature Entering Evaporator Coil, Degree F																				
		65°	70°	75°	80°	85°	90°	95°	100°	105°	110°	115°										
COOLING INPUT (1000 BTU)	Pressure																					
	Suction	24	148	147	147	147	147	147	147	147	148	149	151	153	155	157						
		36	140	141	142	143	144	145	146	147	145	146	147	149	150	152						
		48	143	143	143	143	143	144	146	148	144	146	148	150	152	155						
60	139	139	138	139	139	140	142	143	143	140	142	143	145	147	150							
Liquid	24	212	238	264	289	313	337	360	382	404	425	445										
	36	248	267	287	308	331	355	380	407	435	465	496										
	48	252	273	295	318	342	366	392	419	446	475	504										
	60	258	277	298	319	341	365	391	415	442	470	499										

**Table 6. Cooling Performance - HP / DF Models**

80 DB / 67 WB Deg. Return Air		Air Temperature Entering Evaporator Coil, Degree F																				
		65°	70°	75°	80°	85°	90°	95°	100°	105°	110°	115°										
COOLING INPUT (1000 BTU)	Pressure																					
	Suction	24	144	145	146	147	148	149	151	153	154	156	159									
		36	136	138	139	140	142	144	146	147	149	152	154									
		48	143	141	141	141	141	142	144	146	148	151	155									
60	138	138	139	139	140	141	143	144	145	147	149											
Liquid	24	232	251	270	291	312	335	358	382	407	434	461										
	36	242	260	279	299	321	344	369	394	422	450	480										
	48	238	257	277	299	321	344	368	394	420	448	476										
	60	247	267	288	310	333	357	381	408	434	462	491										

**Table 7. Heating Performance - HP / DF Models**

70 Deg. F Return Air		Air Temperature Entering Evaporator Coil, Degree F											
COOLING INPUT (1000 BTU)	Pressure	0°	5°	10°	17°	20°	25°	35°	40°	47°	50°	55°	60°
24	Suction	39	43	48	56	60	67	82	90	102	108	118	129
36		27	32	38	46	50	56	71	79	91	96	106	115
48		34	38	43	50	54	61	76	84	97	103	113	124
60	Liquid	36	41	46	55	58	65	80	87	99	104	113	123
24		309	304	300	299	299	301	310	317	330	336	348	362
36		284	292	300	311	316	324	341	350	363	369	378	388
48		272	278	284	294	299	308	328	339	356	364	377	392
60		326	325	326	330	332	337	352	361	374	384	397	412

# Wiring Diagrams

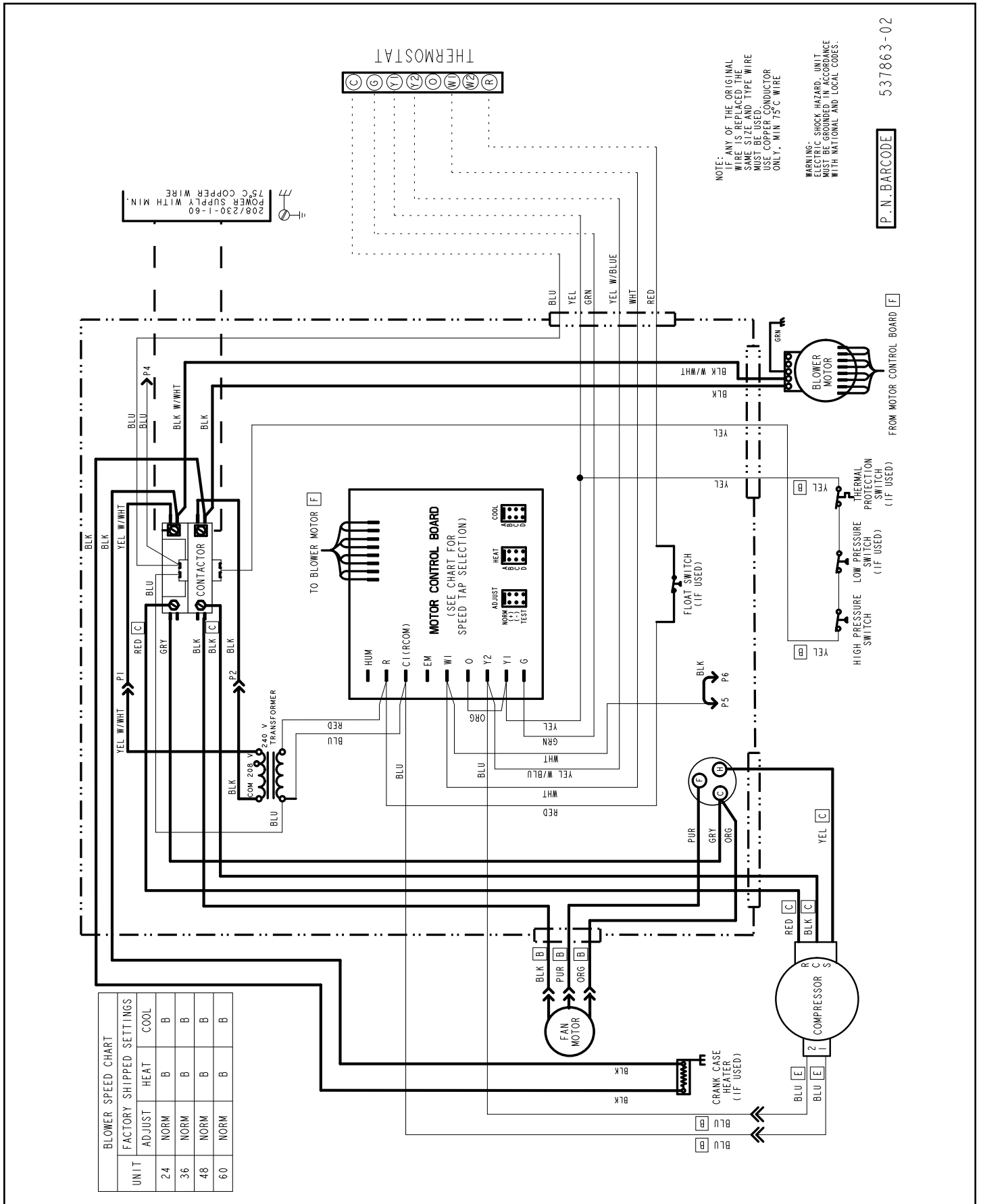

BLOWER SPEED CHART	
UNIT	FACTORY SHIPPED SETTINGS
	ADJUST    HEAT    COOL
24	NORM    B    B
36	NORM    B    B
48	NORM    B    B
60	NORM    B    B

**Figure 8. AC Wiring Diagram**

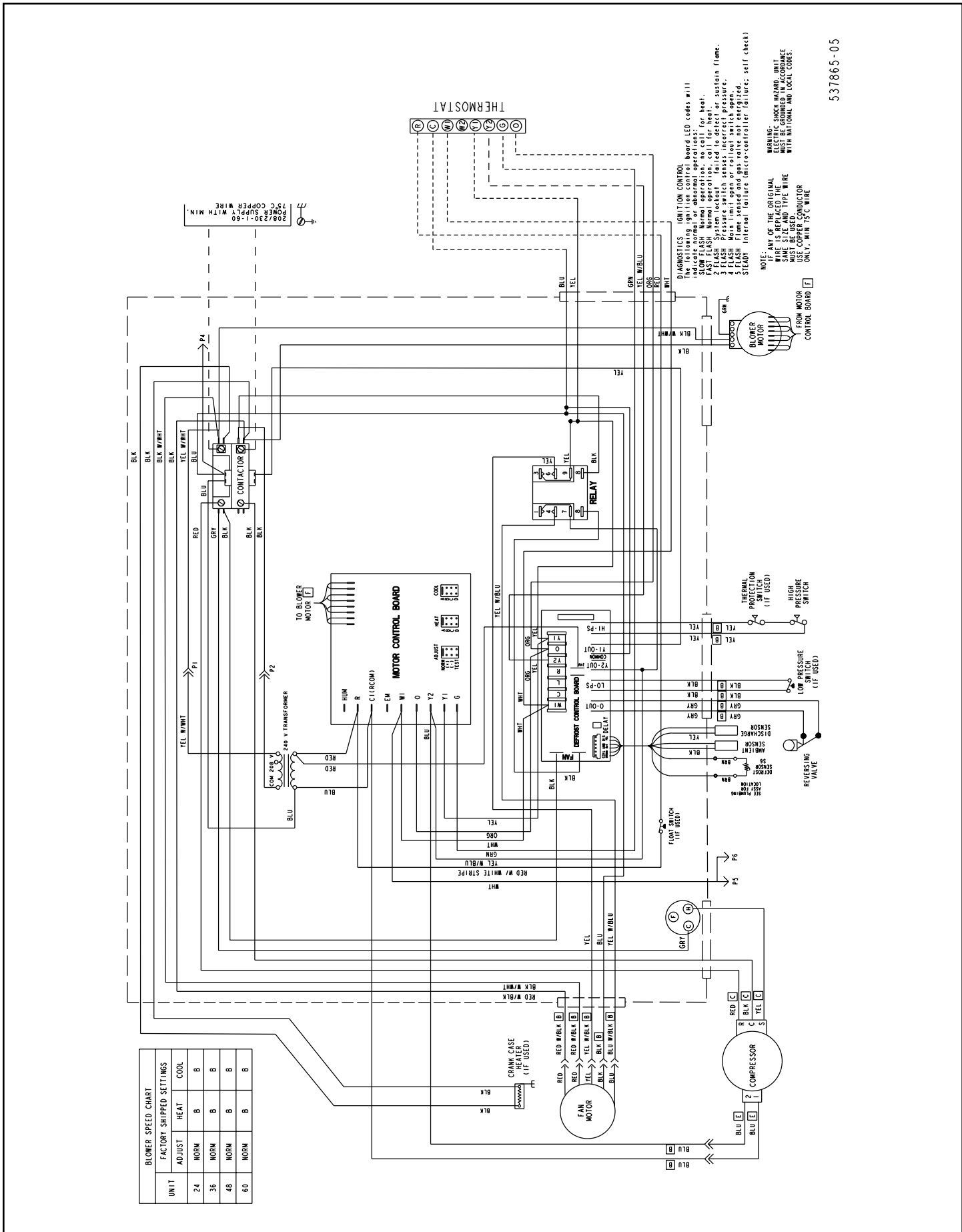

Figure 9. HP Wiring Diagram