

WHES**LIGHT-DUTY COMMERCIAL ELECTRIC WATER HEATER**

Surface Mounted Thermostats | Top Connect | 60Hz

**COMMERCIAL
PRODUCT SPECIFICATIONS (EHB)****80 Gallons
240/277V-1/3Ph****FEATURES****Terminal Block**

- Allows for easy field conversion from simultaneous to non-simultaneous and single-phase to three-phase wiring

Fully Automatic Surface Mounted Thermostats

- Controls temperature, combined with a manual energy cut-off to prevent overheating

Dual Heating Elements

- Screw in, Incoloy superalloy
- Low wattage density
- Ensures more efficient operation and longer element life

SediMotion™ Turbulence-Inducing Dip Tube

- Engineered to reduce sediment buildup inside the tank

Factory Installed Heat Traps

- Reduces standby heat loss caused by heat mitigation to water pipes

Full Flow Brass Drain Valve

- Allows easy and quick drainage

Temperature And Pressure Relief Valve

- Factory provided and installed on side of tank

PERFORMANCE**HFO Foam Insulated**

- Two-inch thick, environmentally-friendly insulation foam
- Saves energy, reduces fuel cost by maximizing heat retention
- Contributes to overall energy efficiency

QUALITY**Heavy Gauge Steel Tank**

- Extra years of trouble-free service

Permaclad™ Glass-Lined Tank

- Lined and fired at 1600°F for optimum protection from the effects of corrosion

Magnesium Anode Rod

- Prolongs tank life

WARRANTY

- Tank - Limited six years in residential applications, one year in non-residential applications
- Components - Limited six years in residential applications, one year in non-residential applications

NOTE - Refer to Lennox® Basic Limited Warranty at www.Lennox.com for additional details.

**APPROVALS**

- Certified to UL 1453
- Tested in accordance with U.S. DOE test procedures
- AHRI Certified
- Meets or Exceeds DOE Efficiency Requirements

MODEL NUMBER IDENTIFICATION

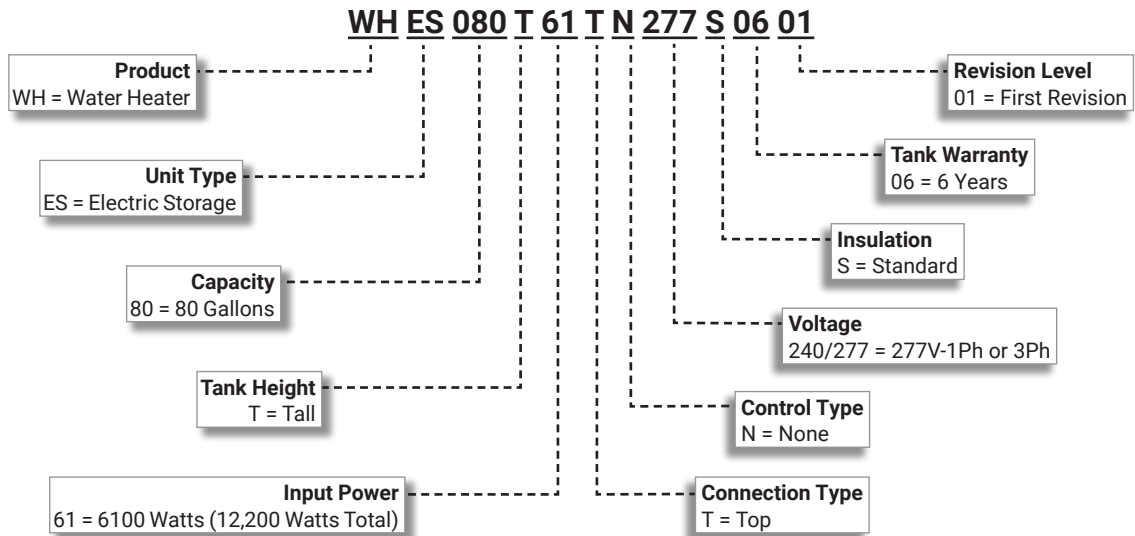

SPECIFICATIONS

Model		WHES080T61TN277S06
Insulation		Standard
Nominal Capacity	Gallons	80
DOE Rated Capacity	Gallons	73
Line voltage data (Volts-Phase-Hz)		240/277-1-60 240/277-3-60
Element Wattage (total)		12,200
Shipping Weight	lbs.	212

NOTES - All models are certified at 300 PSI test pressure and 150 PSI working pressure.

RECOVERY RATES / CAPACITIES

Input (Watts)	Recovery - U.S. Gallons/Hr. (GPH) and Liters/Hr. (LPH) at Various Temperature Rises									
	Temperature - °F	40	50	60	70	80	90	100	110	120
12,200	Gallons/Hour	126	101	84	72	63	56	50	46	42
	Temperature - °C	22.2	27.8	33.3	38.9	44.4	50	55.6	61.1	66.7
	Liters/Hour	477	382	318	273	239	212	191	173	159

DIMENSIONS

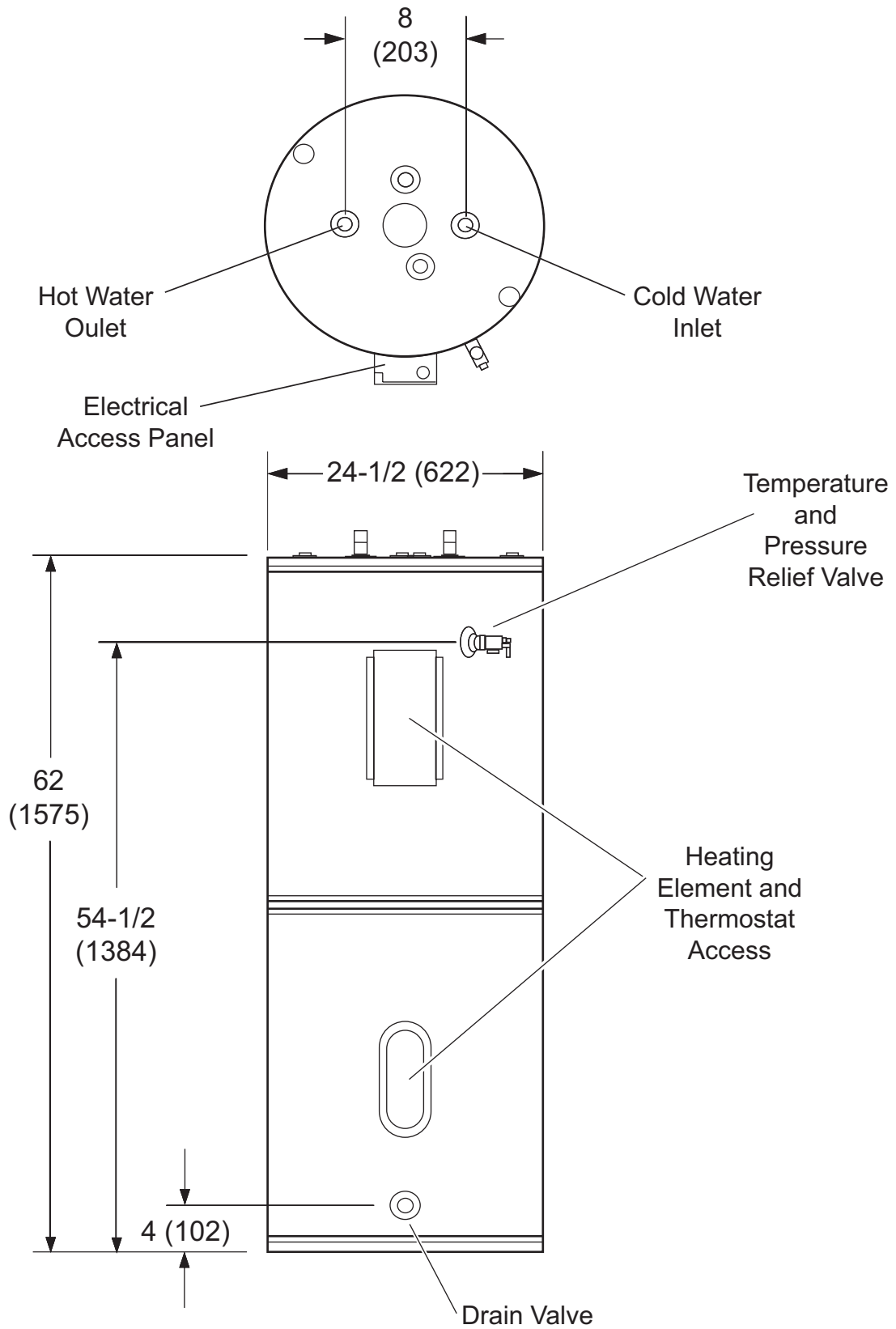



Visit us at www.Lennox.com

For the latest technical information, www.LennoxPros.com

Contact us at 1-800-9-LENNOX

NOTE - Due to Lennox' ongoing commitment to quality, Specifications, Ratings and Dimensions subject to change without notice and without incurring liability. Improper installation, adjustment, alteration, service or maintenance can cause property damage or personal injury. Installation and service must be performed by a qualified installer and servicing agency.

©2026 Lennox Industries, Inc.