

# ML14KC1

MERIT® SERIES

Single-Stage | Quantum™ Coil | **R-454B** | 1-Phase | 60Hz

RESIDENTIAL  
PRODUCT SPECIFICATIONS (EHB)



1.5 to 5 Tons

SEER2 up to 17.0

Cooling Capacity | 17,000 to 60,000 Btuh



**MERIT**®  
SERIES



2025 COMPLIANT  
REFRIGERANT

## MODEL NUMBER IDENTIFICATION

**ML 14 K C 1 - 036 - 230 A 01**

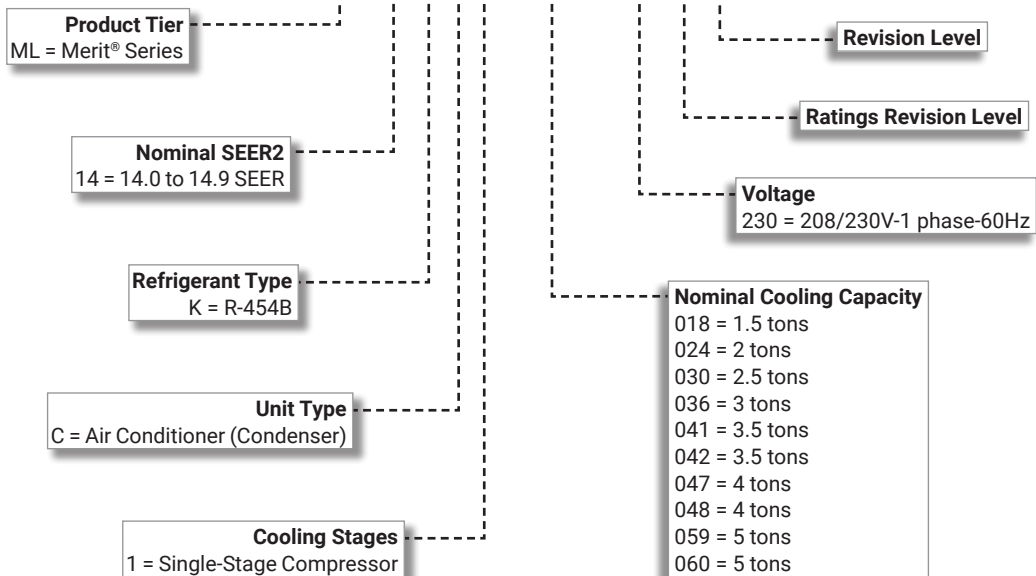

## FEATURE HIGHLIGHTS

1. Outdoor Coil Fan
2. Quantum™ Coil
3. Scroll Compressor
4. Heavy Gauge Steel Cabinet
5. Refrigerant Line Connections and Access

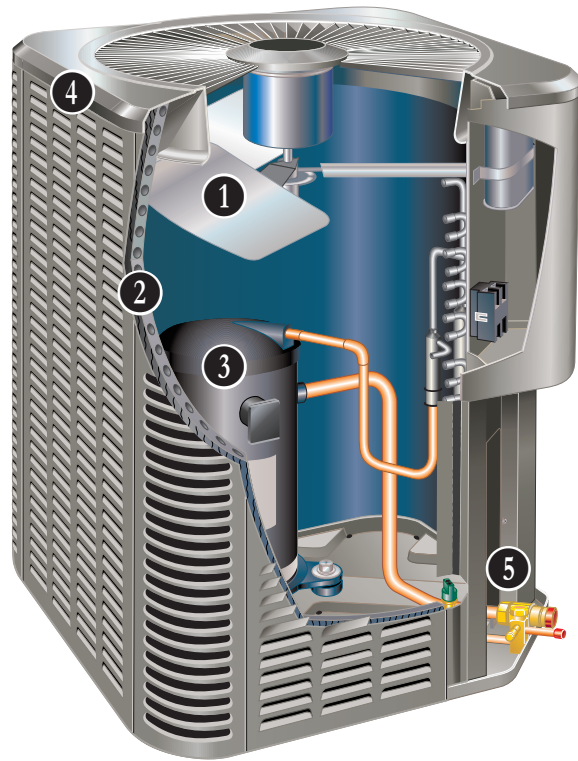

## CONTENTS

Approvals And Warranty . . . . .	3
Control Options . . . . .	6
Dimensions - Unit . . . . .	9
Electrical Data . . . . .	7
Expanded Sound Data . . . . .	10
Features . . . . .	3
Field Wiring . . . . .	10
Installation Clearances . . . . .	10
Model Number Identification. . . . .	1
Optional Accessories - Order Separately . . . . .	7
Specifications . . . . .	7
TXV Substitution - R-454B . . . . .	11
TXV Usage. . . . .	11

## APPROVALS AND WARRANTY

### **APPROVALS**

- AHRI Standard 210/240-2023 certified
- AHRI Certified system match-ups and expanded ratings, visit [www.LennoxPros.com](http://www.LennoxPros.com)
- Sound rated to AHRI Standard 270-2008 test conditions
- Tested in Lennox' Research Laboratory environmental test room
- Rated According to U.S. Department of Energy (DOE) test procedures
- Region specific models meet the minimum efficiency requirements for U.S. DOE Federal Regional Standards in that area
- Unit and components ETL, NEC and CEC bonded for grounding to meet safety standards for servicing
- ETL certified (U.S. and Canada)
- ISO 9001 Registered Manufacturing Quality System

### **WARRANTY**

- Compressor:
  - Limited five years in residential installations
  - Limited five years in non-residential installations
- All other covered components:
  - Limited five years in residential installations
  - Limited one year in non-residential installations

**NOTE** - Refer to Lennox® Basic Limited Warranty at [www.Lennox.com](http://www.Lennox.com) for additional details.

## FEATURES

### **APPLICATIONS**

- 1.5 through 5 tons
- Sound levels as low as 73 dBA
- Single-phase power supply
- Vertical air discharge
- Applicable to indoor air handlers or gas furnaces with indoor add-on coils
- Shipped completely factory assembled, piped and wired

### **REFRIGERATION SYSTEM**

#### **R-454B Refrigerant**

- Low GWP (Global Warming Potential)
- Zero ODP (Ozone Depletion Potential)
- Low Toxicity/Lower Flammability - A2L
- Unit is factory pre-charged

**NOTE** - Total system refrigerant charge is dependent on outdoor unit size, indoor unit size and refrigerant line length.

**NOTE** - Refer to the unit-mounted charging sticker to determine correct amount of charge required.

#### **1 Outdoor Coil Fan**

- Direct drive fan
- Vertical air discharge
- Totally enclosed fan motor
- Ball bearings
- Inherently protected
- Motor rain shield
- Louvered steel fan guard

#### **2 Quantum™ Coil**

- Lennox designed and fabricated coil
- Enhanced aluminum alloy tube/enhanced fin coil
- Superior corrosion resistance
- Ripple-edged aluminum fins
- Aluminum tube construction
- Lanced fins for maximum fin surface exposure
- Fin collars grip tubing for maximum contact area
- Flared shoulder tubing connections
- Factory tested under high pressure
- Entire coil is accessible for cleaning

#### **High Capacity Liquid Line Drier**

- Furnished with unit for field installation
- Traps any moisture or dirt that could contaminate the refrigerant system
- 100% molecular-sieve, bead type

#### **High Pressure Switch**

- Protects the system from high pressure conditions that can be a result of fan failure or a blocked/dirty coil
- Automatic reset

#### **Low Pressure Switch**

- Shuts off unit if suction pressure falls below setting
- Provides loss of charge and freeze-up protection
- Automatic reset

## FEATURES

### **REFRIGERATION SYSTEM (Continued)**

#### **Optional Accessories**

##### **Expansion Valve Kits**

- Field installed on indoor units (if required)
- See TXV Usage table
- Chatleff-style fitting

##### **Freezestat**

- Senses suction line temperature
- Cycles compressor off when suction line temperature falls below freezestat setpoint
- Opens at 29°F and closes at 58°F
- Installs on or near the discharge line of the evaporator or on the suction line

##### **Loss of Charge Switch Kit**

- Protects compressor from damage from low refrigerant charge conditions
- SPST, normally-closed
- Automatic reset

##### **Refrigerant Line Kits**

- Refrigerant lines are shipped refrigeration clean
- Lines are cleaned, dried, pressurized and sealed at factory
- Suction line fully insulated
- Lines are stubbed at both ends

### **INDOOR REFRIGERANT DETECTION SYSTEM (RDS)**

- Complies with UL 60335-2-40 approved standard
- Required for all systems using R-454B refrigerant
- Factory or field installed on all indoor units
- Consists of a RDS refrigerant detection sensor and a mitigation control in the indoor unit
- Ensures safe operation for systems equipped with R-454B refrigerant
- Indoor sensor will detect any R-454B refrigerant
- If R-454B refrigerant is detected, the refrigerant detection system will stop compressor operation and operate the blower to reduce concentrations in the conditioned space
- Once safe levels are reached the HVAC system will resume normal operation
- Refer to indoor unit Product Specifications documents for additional details

### **COMPRESSOR**

#### **3 Single-Stage Scroll Compressor**

- High volumetric efficiency
- Uniform suction flow
- Constant discharge flow
- Quiet operation
- Low gas pulses during compression reduces operational sound levels
- Compressor motor is internally protected from excessive current and temperature
- Muffler in discharge line reduces operating sound levels
- Compressor is installed in the unit on resilient rubber mounts for vibration free operation

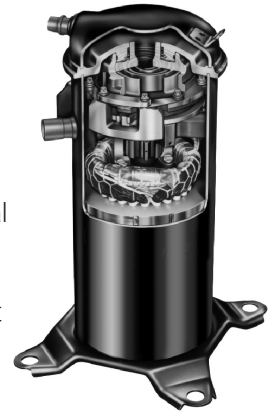

#### **Scroll Compressor Operation**

- Two involute spiral scrolls matched together generate a series of crescent-shaped gas pockets between them
- During compression, one scroll remains stationary while the other scroll orbits around it
- Gas is drawn into the outer pocket, the pocket is sealed as the scroll rotates
- As the spiral movement continues, gas pockets are pushed to the center of the scrolls. Volume between the pockets is simultaneously reduced
- When the pocket reaches the center, gas is now at high pressure and is forced out of a port located in the center of the fixed scrolls
- During compression, several pockets are compressed simultaneously resulting in a smooth continuous compression cycle
- Continuous flank contact, maintained by centrifugal force, minimizes gas leakage and maximizes efficiency
- Compressor is tolerant to the effects of slugging and contaminants. If this occurs, scrolls separate, allowing liquid or contaminants to be worked toward the center and discharged

#### **Compressor Crankcase Heater (041 through 060 Models)**

- Prevents migration of liquid refrigerant into compressor and ensures proper compressor lubrication

#### **Optional Accessories**

#### **Compressor Crankcase Heater (018 through 036 Models)**

- Prevents migration of liquid refrigerant into compressor and ensures proper compressor lubrication

#### **Compressor Sound Cover**

- Reinforced vinyl compressor cover
- 1-1/2 inch thick batt fiberglass insulation
- All open edges are sealed with a one-inch wide hook and loop fastening tape

## FEATURES

### **COMPRESSOR (continued)**

#### Optional Accessories (continued)

##### **Compressor Hard Start Kit**

- Single-phase units are equipped with a PSC compressor motor
- This type of motor normally does not need a potential relay and start capacitor
- For conditions such as low voltage, kit may be required to increase the compressor starting torque

##### **Compressor Low Ambient Cut-Off Switch**

- Non-adjustable switch (low ambient cut-out)
- Prevents compressor operation when outdoor temperature is below 35°F

##### **Compressor Time-Off Control**

- Kit prevents compressor short-cycling
- Allows time for suction and discharge pressure to equalize.
- Permits compressor start-up in an unloaded condition.
- Automatic reset with 5 minute delay between compressor shut-off and start-up

### **CONTROLS**

#### Optional Accessories

##### **Thermostat**

- Thermostat is not furnished with unit
- See Page 6

##### **Indoor Blower Off Delay Relay**

- Delays the indoor blower-off time during the cooling cycle

##### **Low Ambient Kit**

- Air conditioners can operate down to 45°F outdoor air temperature without additional controls
- Allows unit to operate properly down to 30°F

**NOTE** - Crankcase heater and freezestat should be installed on compressors equipped with a low ambient kit.

**NOTE** - A compressor lock-out thermostat should be added to terminate compressor operation below recommended operation conditions.

### **CABINET**

- 4 • Heavy gauge steel construction
- Louvered heavy gauge steel panels surround unit on all four sides
- Pre-painted powder paint cabinet finish
- Control box is conveniently located with all controls factory wired
- Corner patch plate allows access to compressor components
- Drainage holes are provided in base section for moisture removal

#### **Zinc-Coated Steel Unit Base**

- Resists rust and corrosion

#### 5 **Refrigerant Line Connections, Electrical Inlets, Service Valves**

- Sweat connection suction and liquid lines
- Located on corner of unit cabinet
- Suction valve can be fully shut off, while liquid valve may be front seated to manage refrigerant charge while servicing system
- Refrigerant line connections and field wiring inlets are located in one central area of the cabinet
- See dimension drawing

#### **Braze-Free/Press Fitting Flexibility**

- Units can accommodate braze-free or press fittings for installation versatility

#### Optional Accessories

##### **Unit Stand-Off Kit**

- Black high density polyethylene feet raise unit off of mounting surface
- Four feet are furnished per order number

## CONTROL OPTIONS

### E30 Smart Wi-Fi Thermostat

- 4 Htg.-2 Clg.
- 7-day, universal, programmable, touchscreen thermostat
- Controls dehumidification during cooling mode and humidification during heating mode
- Smooth Setback Recovery and compressor short-cycle protection
- One-Touch Away Mode, Smart Away™ (geo-fencing), equipment maintenance reminders and scheduling
- Smart home automation compatible with Apple HomeKit™, Amazon Alexa® and Google Assistant
- Lennox® Home App controls temperature, fan operation, set programs/schedules and set Away mode on a smartphone
- Lennox Smart Tech App allows the installer to commission the system and remotely turn the system on and off during setup or service call on a smartphone



### M30 Smart Wi-Fi Thermostat

- 4 Htg.-2 Clg.
- 7-day, universal, programmable, touchscreen thermostat
- Humidification / dehumidification / dewpoint measurement and control, Humiditrol® control
- Smooth Setback Recovery and compressor short-cycle protection
- One-Touch Away Mode, Smart Away™ (geo-fencing), equipment maintenance reminders and scheduling
- Smart home automation compatible with Apple HomeKit™, Amazon Alexa® and Google Assistant
- Lennox® Home App controls temperature, fan operation, set programs/schedules and set Away mode on a smartphone
- Lennox Smart Tech App allows the installer to commission the system and remotely turn the system on and off during setup or service call on a smartphone



**NOTE** - Please refer to the individual Product Specifications for these products for full information.

## CONTROLS - ORDERING

E30 Smart Wi-Fi Thermostat	5 x 7-1/2 x 1	<b>20A65</b>
M30 Smart Wi-Fi Thermostat	3-5/16 x 4-5/16 x 7/8	<b>15Z69</b>
<b>Thermostat Accessories</b>		
<sup>1</sup> Discharge Air Temperature Sensor (For E30)		<b>88K38</b>
<sup>2</sup> Remote Outdoor Air Temperature Sensor (For dual-fuel and Humiditrol®)		<b>X2658</b>

<sup>1</sup> Optional for service diagnostics (E30).

<sup>2</sup> Remote Outdoor Air Temperature Sensor is used with conventional (non-Lennox® Communicating) outdoor units (sensor is furnished with Lennox® Communicating outdoor units). Allows the thermostat to display outdoor temperature. Required in dual-fuel and Humiditrol® applications.

SPECIFICATIONS				ALL REGIONS		
Size		018	024	030	036	041
<b>Nominal Tonnage</b>		1.5	2	2.5	3	3.5
<b>Sound Rating Number</b> dBA		73	75	76	76	75
<b>Connections</b> Liquid line (OD) - in.		3/8	3/8	3/8	3/8	3/8
<b>(Sweat)</b> Suction line (OD) - in.		3/4	3/4	3/4	7/8	7/8
<b>Compressor Type</b>		1-Stage Scroll	1-Stage Scroll	1-Stage Scroll	1-Stage Scroll	1-Stage Scroll
<b>Refrigerant (15 ft. Line Set)</b> <sup>1</sup> R-454B charge furnished		4 lbs. 14 oz.	4 lbs. 14 oz.	5 lbs. 10 oz.	6 lbs. 13 oz.	7 lbs. 7 oz.
<b>Refrigerant (30 ft. Line Set)</b> <sup>1</sup> R-454B charge furnished		5 lbs. 7 oz.	5 lbs. 7 oz.	6 lbs. 3 oz.	7 lbs. 6 oz.	8 lbs. 0 oz.
<b>Indoor Unit Expansion Valve (TXV)</b>		<b>26Z70</b>	<b>26Z70</b>	<b>26Z70</b>	<b>26Z70</b>	<b>26Z71</b>
<b>Outdoor Coil</b> Net face area - ft. <sup>2</sup> Outer coil		16.33	21.00	16.33	21.00	22.17
		Inner coil	---	15.75	20.25	21.33
		Tube diameter - in.	5/16	5/16	5/16	5/16
		Rows	1	1	2	2
		Fins - in.	26	26	22	22
<b>Outdoor Fan</b> HP		1/8	1/8	1/8	1/6	1/3
		Diameter - in.	22	22	22	26
		Blades	2	3	3	3
		Cfm	2610	2990	2820	3040
		Rpm	825	825	825	825
		Watts	160	160	160	190
<b>Shipping Data - lbs.</b>		155	170	180	200	225
ELECTRICAL DATA						
Line voltage data (Volts-Phase-Hz)		208/230-1-60	208/230-1-60	208/230-1-60	208/230-1-60	208/230-1-60
<sup>2</sup> Maximum overcurrent protection (MOCP) amps		15	20	25	30	30
<sup>3</sup> Minimum circuit ampacity (MCA)		11.2	13.6	16.6	21.8	21
<b>Compressor</b> Rated load amps		8.3	10.3	12.7	16.7	14.7
		Locked rotor amps	45	60.2	75.6	93.5
<b>Fan Motor</b> Full load amps		0.74	0.74	0.74	1.0	2.6
		Locked rotor amps	1.65	1.65	1.65	1.9
						---
OPTIONAL ACCESSORIES - ORDER SEPARATELY						
<b>Compressor</b> Copeland <b>27V63</b>		•	•	•	•	Factory
<b>Crankcase Heater</b> LG <b>27U16</b>		•	•	•	•	Factory
<b>Compressor Hard Start Kit</b> Copeland <b>63W22</b>		•				
		<b>10J42</b>	•	•	•	•
		LG <b>10J42</b>	•	•	•	•
<b>Compressor Low Ambient Cut-Off Switch</b> <b>45F08</b>		•	•	•	•	•
<b>Compressor Sound Cover</b> <b>18J42</b>		•	•	•	•	•
<b>Compressor Timed-Off Control</b> <b>47J27</b>		•	•	•	•	•
<b>Freezestat</b> 3/8 in. <b>93G35</b>		•	•	•	•	•
<b>Indoor Blower Off Delay Relay</b> <b>58M81</b>		•	•	•	•	•
<b>Loss of Charge Switch Kit</b> <b>84M23</b>		•	•	•	•	•
<sup>4</sup> <b>Low Ambient Kit (Fan Cycling)</b> <b>34M72</b>		•	•	•	•	•
<b>Refrigerant Line Sets</b> 3/8 x 3/4   3/8   20 ft. <b>89J56</b>						
		3/8 x 3/4   3/8   30 ft. <b>89J57</b>				
Liquid x Suction OD   Insulation Thickness   Length		3/8 x 3/4   3/8   40 ft. <b>89J58</b>	•	•	•	
		3/8 x 3/4   3/8   50 ft. <b>89J59</b>				
		3/8 x 7/8   3/8   30 ft. <b>89J60</b>				
		3/8 x 7/8   3/8   40 ft. <b>89J61</b>			•	•
		3/8 x 7/8   3/8   50 ft. <b>89J62</b>				
<b>Unit Stand-Off Kit</b> <b>94J45</b>		•	•	•	•	•

NOTE - Extremes of operating range are plus 10% and minus 5% of line voltage.

<sup>1</sup> Refrigerant charge sufficient for the line set length listed in parenthesis. For longer line set requirements see the Installation Instructions or unit Charging Label for information about line set length and additional refrigerant charge required.

<sup>2</sup> HACR type breaker or fuse.

<sup>3</sup> Refer to National or Canadian Electrical Code manual to determine wire, fuse and disconnect size requirements.

<sup>4</sup> Crankcase Heater and Freezestat are recommended with Low Ambient Kit.

SPECIFICATIONS	ALL REGIONS				
----------------	-------------	--	--	--	--

<b>Size</b>		<b>042</b>	<b>047</b>	<b>048</b>	<b>059</b>	<b>060</b>
<b>Nominal Tonnage</b>		3.5	4	4	5	5
<b>Sound Rating Number</b>	dBA	76	76	78	78	80
<b>Connections (Sweat)</b>	Liquid line (OD) - in.	3/8	3/8	3/8	3/8	3/8
	Suction line (OD) - in.	7/8	7/8	7/8	1-1/8	1-1/8
<b>Compressor Type</b>		1-Stage Scroll	1-Stage Scroll	1-Stage Scroll	1-Stage Scroll	1-Stage Scroll
<b>Refrigerant (15 ft. Line Set)</b>	<sup>1</sup> R-454B charge furnished	7 lbs. 2 oz.	7 lbs. 13 oz.	8 lbs. 14 oz.	9 lbs. 8 oz.	8 lbs. 14 oz.
<b>Refrigerant (30 ft. Line Set)</b>	<sup>1</sup> R-454B charge furnished	7 lbs. 11 oz.	8 lbs. 6 oz.	9 lbs. 7 oz.	10 lbs. 1 oz.	9 lbs. 7 oz.
<b>Indoor Unit Expansion Valve (TXV)</b>		<b>26Z71</b>	<b>26Z71</b>	<b>26Z71</b>	<b>26Z72</b>	<b>26Z72</b>
<b>Outdoor Coil</b>	Net face area - ft. <sup>2</sup> Outer coil	22.17	22.17	24.93	29.09	29.09
	Inner coil	21.33	21.33	24.13	28.16	28.16
	Tube diameter - in.	5/16	5/16	5/16	5/16	5/16
	Rows	2	2	2	2	2
	Fins - in.	22	22	22	22	22
<b>Outdoor Fan</b>	HP	1/4	1/3	1/4	1/3	1/4
	Diameter - in.	26	26	22	26	26
	Blades	3	3	4	4	4
	Cfm	4060	3920	3700	4050	4180
	Rpm	825	825	825	825	825
	Watts	260	180	290	220	290
<b>Shipping Data - lbs.</b>		225	225	235	260	260

ELECTRICAL DATA					
-----------------	--	--	--	--	--

Line voltage data (Volts-Phase-Hz)	208/230-1-60	208/230-1-60	208/230-1-60	208/230-1-60	208/230-1-60	
<sup>2</sup> Maximum overcurrent protection (MOCP) amps	35	40	45	55	50	
<sup>3</sup> Minimum circuit ampacity (MCA)	23.2	25.2	29.7	31.8	31.2	
<b>Compressor</b>	Rated load amps	17.3	18.1	22.4	23.3	23.7
	Locked rotor amps	123	126	126	143	157
<b>Fan Motor</b>	Full load amps	1.56	2.6	1.7	2.6	1.56
	Locked rotor amps	3.2	---	3.2	---	3.2

OPTIONAL ACCESSORIES - ORDER SEPARATELY					
---	--	--	--	--	--

<b>Compressor Hard Start Kit</b>	Copeland	<b>10J42</b>	•	•	•	•	•
	LG	<b>10J42</b>	•				
	LG	<b>88M91</b>		•	•	•	•
<b>Compressor Low Ambient Cut-Off Switch</b>		<b>45F08</b>	•	•	•	•	•
<b>Compressor Sound Cover</b>		<b>18J42</b>	•	•	•	•	•
<b>Compressor Timed-Off Control</b>		<b>47J27</b>	•	•	•	•	•
<b>Freezestat</b>	3/8 in.	<b>93G35</b>	•	•	•	•	•
<b>Indoor Blower Off Delay Relay</b>		<b>58M81</b>	•	•	•	•	•
<b>Loss of Charge Switch Kit</b>		<b>84M23</b>	•	•	•	•	•
<sup>4</sup> <b>Low Ambient Kit (Fan Cycling)</b>		<b>34M72</b>	•	•	•	•	•
<b>Refrigerant Line Sets</b>	3/8 x 7/8   3/8   30 ft.	<b>89J60</b>					
	3/8 x 7/8   3/8   40 ft.	<b>89J61</b>	•	•	•		
Liquid x Suction OD   Insulation Thickness   Length	3/8 x 7/8   3/8   50 ft.	<b>89J62</b>					
	3/8 x 1-1/8   3/8   50 ft.	<b>73P91</b>				•	•
<b>Unit Stand-Off Kit</b>		<b>94J45</b>	•	•	•	•	•

NOTE - Extremes of operating range are plus 10% and minus 5% of line voltage.

<sup>1</sup> Refrigerant charge sufficient for the line set length listed in parenthesis. For longer line set requirements see the Installation Instructions or unit Charging Label for information about line set length and additional refrigerant charge required.

<sup>2</sup> HACR type breaker or fuse.

<sup>3</sup> Refer to National or Canadian Electrical Code manual to determine wire, fuse and disconnect size requirements.

<sup>4</sup> Crankcase Heater and Freezestat are recommended with Low Ambient Kit.

# DIMENSIONS - UNIT

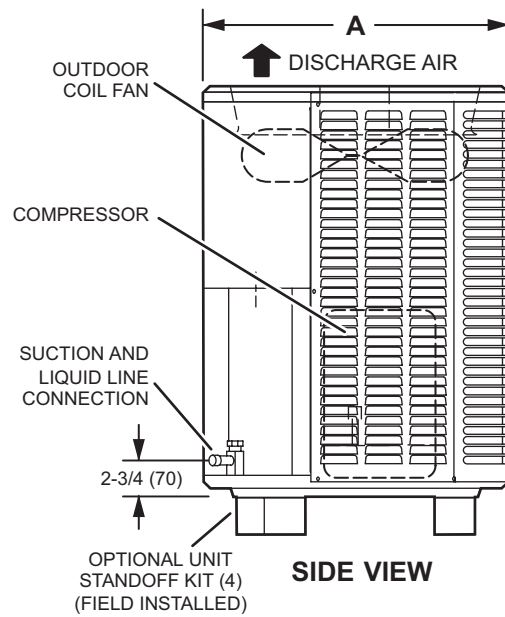
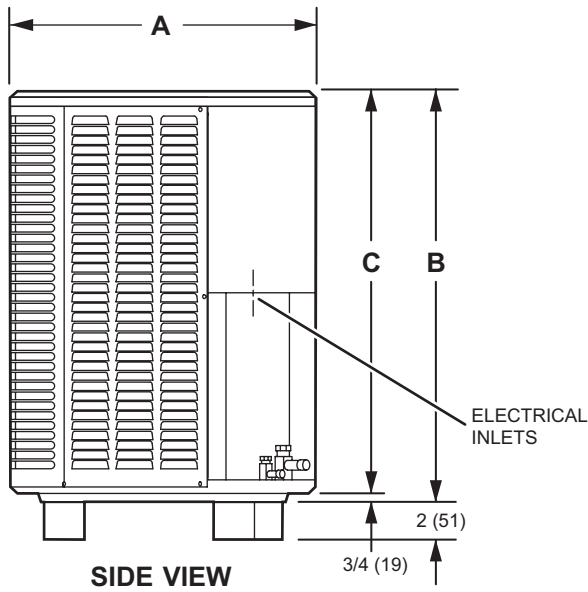
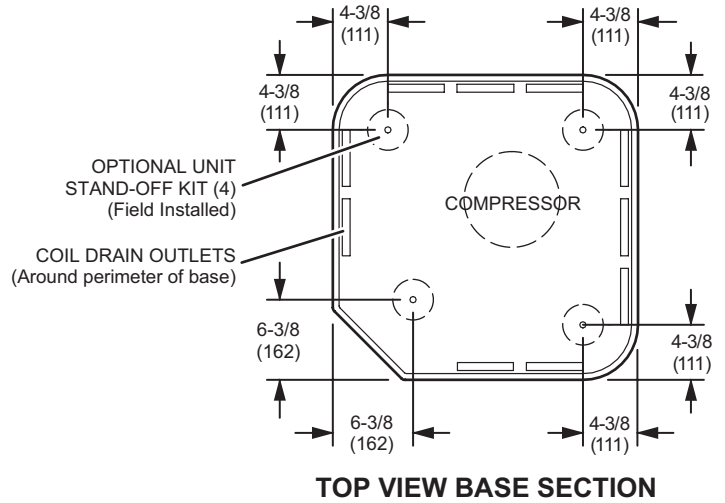
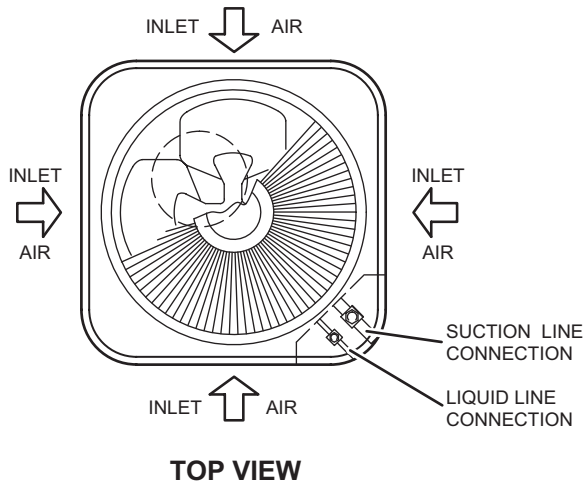

Size	A Width and Depth		B Height		C	
	inches	mm	inches	mm	inches	mm
018	28-1/4	718	29-1/4	743	28-1/2	724
024	28-1/4	718	37-1/4	946	36-1/2	927
030	28-1/4	718	29-1/4	743	28-1/2	724
036	28-1/4	718	37-1/4	946	36-1/2	927
041	32-1/4	819	33-1/4	845	32-1/2	826
042	32-1/4	819	33-1/4	845	32-1/2	826
047	32-1/4	819	33-1/4	845	32-1/2	826
048	28-1/4	718	43-1/4	1099	42-1/2	1080
059	32-1/4	819	43-1/4	1099	42-1/2	1080
060	32-1/4	819	43-1/4	1099	42-1/2	1080

## EXPANDED SOUND DATA

Size	Octave Band Sound Power Levels dBA, re 10 <sup>-12</sup> Watts Center Frequency - HZ							1 Sound Rating Number (dBA)	2 Estimated Sound Pressure Level at Distance From Unit (dBA at distance in ft.)				
	125	250	500	1000	2000	4000	8000		3	5	10	15	50
018	55.5	64.5	69	67.5	65	61	56	73	66	61	55	52	41
024	61.5	64	70	69.5	66	62.5	54.5	75	68	63	57	54	43
030	60	67	72	70.5	67.5	62.5	56	76	69	64	58	55	44
036	58	67.5	72.5	71.5	66.5	62	54.5	76	69	64	58	55	44
041	63	66.5	69	69.5	66.5	61	54	75	68	63	57	54	43
042	59.5	67.5	71.5	70	69	63.5	57.5	76	69	64	58	55	44
047	61	66	72	71	66.5	63	63.5	76	69	64	58	55	44
048	60	70.5	73.5	72.5	70.5	67	60.5	78	71	66	60	57	46
059	63	69.5	73.5	71.5	69.5	64.5	56.5	78	71	66	60	57	46
060	63.5	69.5	75	75	73	68	62.5	80	73	68	62	59	48

NOTE - the octave sound power data does not include tonal correction.

<sup>1</sup> Tested according to AHRI Standard 270-2008 test conditions.

<sup>2</sup> Estimated sound pressure level at distance based on AHRI Standard 275-2010 method for equipment located on the ground, roof, or on side of building wall with no adjacent reflective surface within 9.8 feet. Sound pressure levels will increase based on changes to assumptions. For other applications, refer to AHRI Standard 275.

## FIELD WIRING

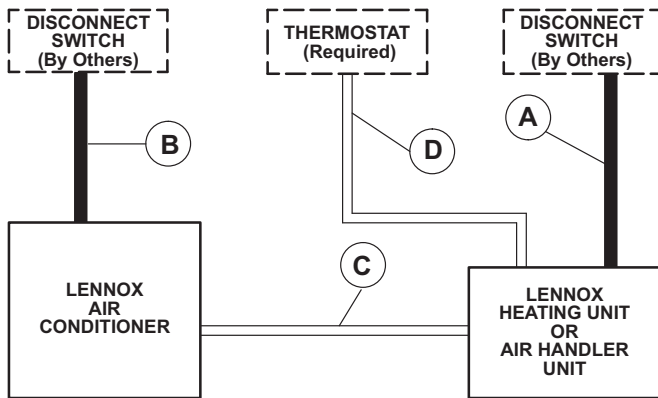

A - Two Wire Power (not furnished). See Indoor Unit Electrical Data  
 B - Two Wire Power (not furnished). See Electrical Data  
 C - Four Wire Low Voltage (not furnished). 18 ga. minimum  
 D - Five Wire Low Voltage (not furnished). 18 ga. minimum

All wiring must conform to NEC or CEC and local electrical codes.

## INSTALLATION CLEARANCES

### NOTES:

- Service Clearance – 30 in. (762 mm) on one of the sides adjacent to the Control Box.
- One of other three sides must be 36 in. (914 mm).
- One of the two remaining sides may be 12 in. (305 mm).
- The remaining side may be 6 in. (152 mm).
- 48 in. (1219 mm) clearance required on top of unit
- 24 in. (610 mm) required between two units

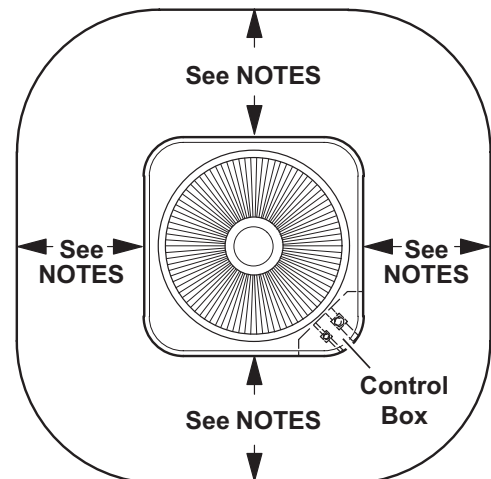

## TXV USAGE

All Lennox coils and air handlers are shipped with a factory installed TXV. In most cases, no substitution is needed.

If a different size TXV is required, it will be listed in the "TXV SUBSTITUTION" table by size. The correct TXV must be ordered separately and field installed.

Size	Order Number
018	<b>26Z70</b>
024	<b>26Z70</b>
030	<b>26Z70</b>
036	<b>26Z70</b>
041	<b>26Z71</b>
042	<b>26Z71</b>
047	<b>26Z71</b>
048	<b>26Z71</b>
059	<b>26Z72</b>
060	<b>26Z72</b>

## AHRI STANDARD 210/240-2023

Standard Ratings relating to cooling or heating capacities shall be net values, including the effects of circulating-fan heat, but not including supplementary electric heat. Power input used for calculating efficiency shall be the Total Power.

Standard Ratings of units which do not have indoor air-circulating fans furnished as part of the model, i.e., Coil-only System, shall be established by subtracting from the total cooling capacity 1,505 Btu/h per 1,000 SCFM, and by adding the same amount to the heating capacity for non-mobile-home, non-Space Constrained units. Total Power for both heating and cooling shall be increased by 441 W per 1,000 SCFM of indoor air circulated.

## TXV SUBSTITUTION - R-454B

A general guide for replacing the factory installed R-454B TXV if the indoor unit (coil/air handler) is larger or smaller than the outdoor unit.

Outdoor Unit		Indoor Unit		Indoor TXV Furnished	Indoor TXV Replacement
Size	Tons	Size	Tons		
018	1.5	42	3.5	<b>26Z71</b>	<b>26Z70</b>
018	1.5	48	4	<b>26Z71</b>	<b>26Z70</b>
018	1.5	49	4	<b>26Z71</b>	<b>26Z70</b>
018	1.5	50/60	4/5	<b>26Z71</b>	<b>26Z70</b>
018	1.5	51/61	4/5	<b>26Z71</b>	<b>26Z70</b>
018	1.5	60	5	<b>26Z72</b>	<b>26Z70</b>
024	2	42	3.5	<b>26Z71</b>	<b>26Z70</b>
024	2	48	4	<b>26Z71</b>	<b>26Z70</b>
024	2	49	4	<b>26Z71</b>	<b>26Z70</b>
024	2	50/60	4/5	<b>26Z71</b>	<b>26Z70</b>
024	2	51/61	4/5	<b>26Z71</b>	<b>26Z70</b>
024	2	60	5	<b>26Z72</b>	<b>26Z70</b>
030	2.5	42	3.5	<b>26Z71</b>	<b>26Z70</b>
030	2.5	48	4	<b>26Z71</b>	<b>26Z70</b>
030	2.5	49	4	<b>26Z71</b>	<b>26Z70</b>
030	2.5	50/60	4/5	<b>26Z71</b>	<b>26Z70</b>
030	2.5	51/61	4/5	<b>26Z71</b>	<b>26Z70</b>
030	2.5	60	5	<b>26Z72</b>	<b>26Z70</b>
036	3	42	3.5	<b>26Z71</b>	<b>26Z70</b>
036	3	48	4	<b>26Z71</b>	<b>26Z70</b>
036	3	49	4	<b>26Z71</b>	<b>26Z70</b>
036	3	50/60	4/5	<b>26Z71</b>	<b>26Z70</b>
036	3	51/61	4/5	<b>26Z71</b>	<b>26Z70</b>
036	3	60	5	<b>26Z72</b>	<b>26Z70</b>
041/042	3.5	24	2	<b>26Z70</b>	<b>26Z71</b>
041/042	3.5	30	2.5	<b>26Z70</b>	<b>26Z71</b>
041/042	3.5	30/36	2.5/3	<b>26Z70</b>	<b>26Z71</b>
041/042	3.5	36	3	<b>26Z70</b>	<b>26Z71</b>
041/042	3.5	60	5	<b>26Z72</b>	<b>26Z71</b>
047/048	4	30/36	2.5/3	<b>26Z70</b>	<b>26Z71</b>
047/048	4	36	3	<b>26Z70</b>	<b>26Z71</b>
047/048	4	60	5	<b>26Z72</b>	<b>26Z71</b>
059/060	5	50/60	4/5	<b>26Z71</b>	<b>26Z72</b>
059/060	5	51/61	4/5	<b>26Z71</b>	<b>26Z72</b>

### TXV Ranges:

- 26Z70** - 1.5 to 3 ton systems - Use on 3 ton (036) and lower systems.
- 26Z71** - 3.5-4 ton systems - Use on 4 ton (047/048) and down to 3.5 ton (041/042) systems.
- 26Z72** - 5 ton systems - Use on 5 ton (059/060) systems only.

## REVISIONS

Sections	Description of Change
Approvals and Warranty	Removed ENERGY STAR® Certification.



Visit us at [www.Lennox.com](http://www.Lennox.com)

For the latest technical information, [www.LennoxPros.com](http://www.LennoxPros.com)

Contact us at 1-800-4-LENNOX

NOTE - Due to Lennox' ongoing commitment to quality, Specifications, Ratings and Dimensions subject to change without notice and without incurring liability. Improper installation, adjustment, alteration, service or maintenance can cause property damage or personal injury. Installation and service must be performed by a qualified installer and servicing agency.

©2026 Lennox Industries, Inc.