

SLP99UHV

DAVE LENNOX SIGNATURE® COLLECTION

Upflow / Horizontal - Variable Capacity - Variable Speed Blower - 60Hz



**RESIDENTIAL
PRODUCT SPECIFICATIONS**

Bulletin No. 210915

July 2024

Supersedes all previous versions



S40 Smart Wi-Fi
Communicating Thermostat
(Not Furnished)



AFUE - Up to 99%
Input - 66,000 to 132,000 Btuh
Nominal Add-on Cooling - 2 to 5 Tons

MODEL NUMBER IDENTIFICATION

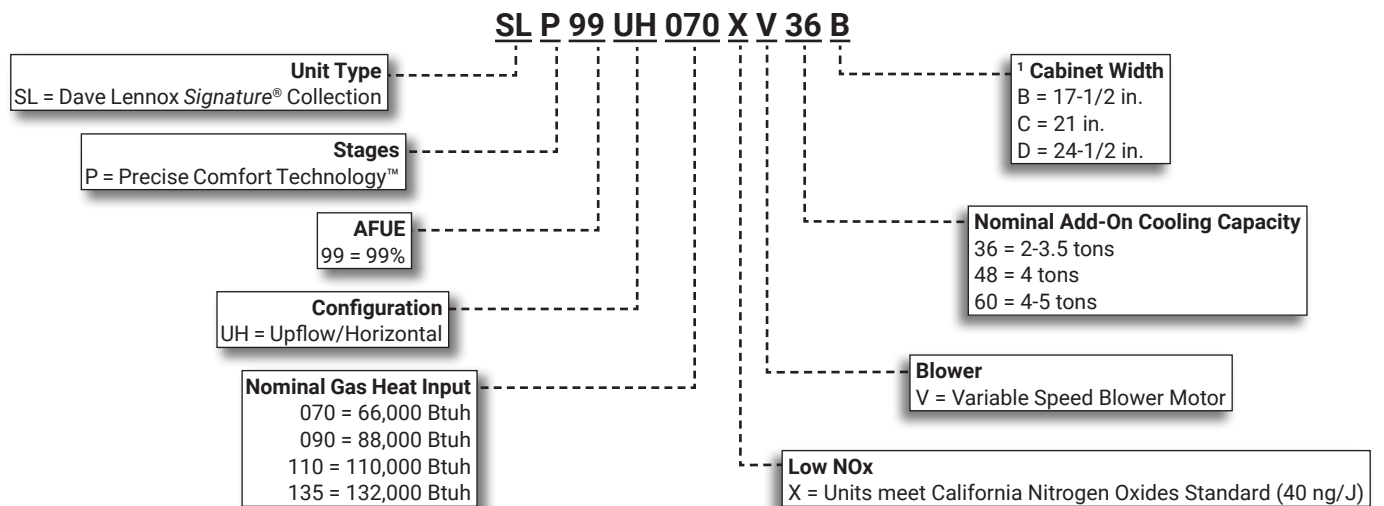

¹ Indoor coils with the same letter designation physically matches the furnace.

FEATURE HIGHLIGHTS

1. SilentComfort™ Technology
2. Lennox Duralok Plus™ Heat Exchanger
3. Secondary Heat Exchanger
4. Inshot Burners
5. Variable Capacity Gas Control Valve
6. Variable-Speed Combustion Air Inducer
7. SureLight® Integrated Furnace Control
8. Variable Speed Direct Drive Blower
9. Insulated Cabinet
10. Safety Interlock Switch
11. Gas Piping And Electrical Inlets

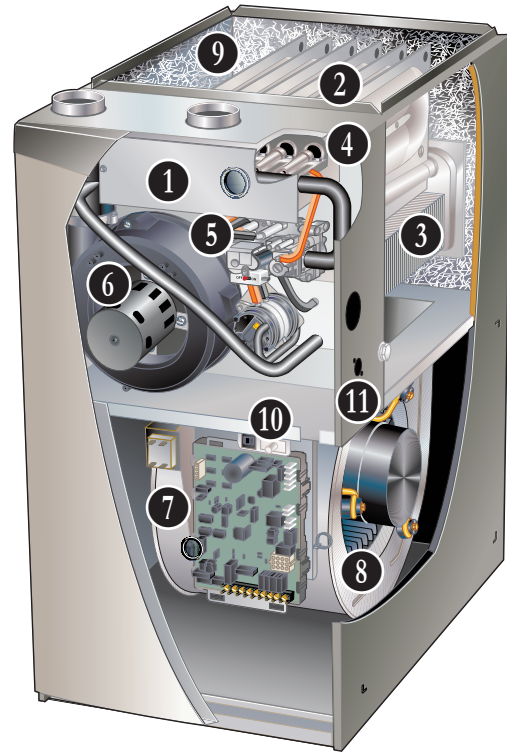

NOTE - SLP99V FURNACES CANNOT BE TWINNED!

CONTENTS

Approvals And Warranty	3
Blower Data	21
Dimensions - Furnace/Coil Combined Dimensions	17
Dimensions - Optional Accessories	16
Dimensions - Optional Accessories - Venting	18
Dimensions - Unit - Horizontal Position	15
Dimensions - Unit - Upflow Position	14
Features	3
Gas Heat Accessories	10
Installation Clearances	13
Optional Accessories - Order Separately	10
Outdoor Termination Kit Usage	11
Specifications	9
Vent Lengths	12
Vent Lengths - Uninsulated Exhaust Pipe In Unconditioned Space	11

APPROVALS AND WARRANTY

APPROVALS

- AHRI Certified
- CSA International Certified
- Tested and rated according to US DOE test procedures and FTC labeling regulations
- Units are approved for installations from 0 - 4500 ft.
- ENERGY STAR® certified units are designed to use less energy, help save money on utility bills, and help protect the environment
- ISO 9001 Registered Manufacturing Quality System
- Blower data from unit tests conducted in Lennox Laboratory air test chamber

NOTE - This furnace has not been CSA International design certified for installation in mobile homes, recreational vehicles, or outdoors.

California Only

- These furnaces **do not meet** the South Coast Air Quality Management District (SCAQMD) Rule 1111 and San Joaquin Valley Air Pollution Control District (SJVAPCD) Rule 4905 NOx emission limit (14 ng/J) and cannot be installed within the SCAQMD, SJVAPCD and Bay Area
- These furnaces **are** approved by the California Energy Commission and meets California Nitrogen Oxides Standard (NOx) limits of 40 ng/J

WARRANTY

- Duralok Plus™ Aluminized Steel Heat Exchanger:
 - Limited lifetime (twenty year transferable) in residential applications
 - Limited ten years in non-residential applications
- All other covered components:
 - Limited ten years in residential installations
 - Limited one year in non-residential installations

NOTE - Refer to Lennox® Basic Limited Warranty at www.Lennox.com for additional details.

FEATURES

APPLICATIONS

- Input capacities of 66,000, 88,000, 110,000 and 132,000 Btuh
- Variable heat capacity in increments as small as 1% or as large as needed within minimum/maximum input range
- Energy efficiency (AFUE) - Up to 99%
- Compact cabinet for upflow, horizontal-right or horizontal-left applications without any modifications
- Variable speed blower ideal for zoning applications
- Lennox add-on indoor coils, high-efficiency air cleaners and humidifiers can easily be added to furnace
- Shipped factory assembled with controls installed and wired
- Each unit factory test operated to ensure proper operation

ZONING APPLICATIONS

- The SLP99V furnace is designed to work with the Lennox® Smart Zoning System with the Lennox® Communicating Thermostat
- The Lennox® Smart Zoning System provides direct feedback to the SLP99V, controlling both airflow and heat output to precisely match the comfort requirements for up to four zones

HEATING SYSTEM

- 1 **SilentComfort™ Technology**
 - Patented burner sound enclosure and extra cabinet insulation reduces operating sound levels
- 2 **Lennox Duralok Plus™ Heat Exchanger Assembly**
 - Lennox developed heat exchanger assembly consists of primary heat exchanger and secondary condenser coil assembly
 - Main multi-pass crimped seam design clamshell type
 - Constructed of heavy-gauge, aluminized steel
 - Designed for normal expansion and contraction with maximum efficiency and minimum resistance to air flow
- 3 **Secondary heat exchanger condenser coil constructed of aluminum fins fitted to stainless steel tubes**
 - Coil is factory tested for leaks
 - Condensate drain header box assembly located on front of coil
 - Compact size permits low overall design of furnace cabinet
 - Laboratory life cycle tested in excess of industry standards

FEATURES

HEATING SYSTEM (continued)

Lennox Designed Header Box

- Header box on end of condenser coil collects flue condensate for disposal through condensate drains
- Drains are located on each side of the cabinet for easy field installation of condensate drain trap
- Only one drain is used, the other drain is sealed
- Condensate drain trap is included with the unit for field installation

Lennox Designed Flue Condensate Trap Assembly

- Field installed outside the conditioned air stream
- Assembly can be mounted on either side of cabinet in upflow applications
- Assembly is mounted below the cabinet in horizontal applications
- Can also be mounted remotely (up to 5 ft. away) from unit
- See Dimension Drawing and Installation Instructions
- 90° street elbow furnished for ease of drain trap installation
- Drain connection can be made with field provided PVC pipe or PVC coupling
- Drain cap on trap allows easy cleaning and winterizing

4 Inshot Burners

- Aluminized steel inshot burners provide efficient, trouble-free operation
- Burner venturi mixes air and gas in correct proportion for proper combustion
- Burner assembly is removable from the unit as a single component for ease of service

5 Variable Capacity Gas Control Valve

- Variable capacity gas control valve adjusts capacity output in increments as small as 1% or as large as needed
- 24 volt redundant combination valve combines manual shut off switch (On-Off), automatic electric valve (dual) and gas pressure regulation into a compact combination control

Flame Rollout Switch

- Factory installed on burner box
- Switch provides protection from abnormal operating conditions
- Manual reset

SureLight® Hot Surface Ignitor

- Tough, reliable, long-life, trouble-free performance
- Silicon nitride ignitor
- Cemented to steatite block for protection against current leakage
- Ignition leads are constructed of nickel plated copper and are enclosed in high temperature Teflon® insulation for dependable operation

6 Variable Speed Combustion Air Inducer

- Three-phase variable speed inducer motor is controlled by the SureLight Control
- Overload protected (auto-reset)
- Heavy-duty blower prepurges heat exchanger and safely vents flue products
- Operates only during heating cycle

7 Pressure Switches (Two-Stage)

- Prove Combustion Air Inducer operation before allowing gas valve to open

Limit Control

- Primary limit is accurately located on vestibule panel
- Automatic reset

Optional Accessories

High Altitude Pressure Switch Kit/High Altitude Conversion Kit

- Required for proper unit operation on installations above 7500 ft. (Switch Kit) or 4500 ft. (Conversion Kit)

Natural Gas to LPG/Propane Conversion Kit

- Required for field changeover from natural gas to LPG/Propane
- Includes gas valve and orifices

LPG/Propane to Natural Gas Conversion Kit

- Required for field changeover from LPG/Propane to natural gas

Muffler (US Only)

- Significantly reduces outdoor operating sound levels
- Two-inch diameter muffler is optional for 070 through 110 input models

NOTE - Two-inch muffler is optional for the 110 input model with a maximum vent pipe length of up to 29 ft. Three-inch diameter muffler is optional for 110 and 135 input models.

NOTE - Three-inch muffler is optional for the 110 input model with a minimum vent pipe length of 30 ft.

- Installed vertically in the exhaust piping
- See Optional Accessory Dimension Drawing

DIRECT VENT SEALED COMBUSTION SYSTEM

- Furnace features a "sealed combustion" system and can only be installed in Direct Vent applications
- In Direct Vent applications, combustion air is supplied from outdoors and flue gases are discharged outdoors

NOTE - Lennox has approved the use of DuraVent® PolyPro® and Centrotherm InnoFlue® manufactured vent pipe and terminations as an alternative to PVC vent pipe. Must be ordered separately. Tested and listed to the ULC S636 standard in Canada

- The polypropylene venting system must follow the uninsulated and unconditioned space vent lengths listed in the table on Page 13
- Refer to the Installation Instructions for additional details

FEATURES

DIRECT VENT SEALED COMBUSTION SYSTEM

(continued)

Flue Coupling (furnished)

- Assists with exhaust flue piping connection and servicing
- Includes flexible one 2-inch rubber coupling and two adjustable bands
- Approved for all Lennox 90% furnaces

Optional Accessories

Vent Termination Kits

- Facilitates installation of combustion air intake pipe and flue exhaust pipe
- Refer to venting table in this bulletin to determine pipe size needed and proper termination kit required
- See Optional Accessories table and dimension drawings

Concentric Termination Kit

- 2 or 3 inch kit contains concentric termination assembly, reducer bushing and 45° elbow
- 2 inch kit for -070 model contains an outdoor exhaust accelerator
- Kit requires single hole penetration of roof or wall for installation
- Roof Termination Flashing Kit available for use 2 inch Kits
- CSA certified

Flush-Mount Termination Kit

- Kit contains flush-mount termination, accelerator, mounting template and hardware
- Kit may be used with 2, 2-1/2 or 3 inch pipe

Wall Assembly Termination Kits

Close Couple (US Only)

- 2 or 3 inch kit consists of close-couple, side-by-side PVC piping with galvanized steel wall cover plate
- Seals and isolates intake and exhaust piping penetration of wall
- Piping spacing and length is sized for proper wall installations
- CSA certified

Close Couple WTK (Canada Only)

- 2 or 3 inch kit contains one insulated faceplate, one insulated exhaust pipe, elbow and fittings

NOTE - Maintain a maximum of 6 inches between the inlet and outlet openings in the installation of the pipes.

Roof Termination Flashing Kit

- For vertical venting through a roof
- 2 or 3 inch kit contains two neoprene rubber roof flashings
- Vent pipe and insulation not furnished
- Flashing Kit can also be used with Concentric Vent Termination Kits used in vertical venting rooftop applications

BLOWER

8 Variable Speed Direct Drive Blower

- Each blower assembly statically and dynamically balanced
- Blower assembly easily removed for servicing

Variable Speed Blower Motor

- Variable speed motor maintains specified air volume from 0 though 0.8 in. w.g. (heating) and 0 through 1.0 in. w.g. (Cooling) static range
- Variable speed operation is achieved by the use of an ECM (Electronically Commutated Motor) motor
- Motor is controlled by furnace control
- Change in blower speed is easily accomplished by simple DIP switch change on furnace control
- See Blower Data tables
- Motor is resiliently mounted

NOTE - When furnaces are used with the Lennox® Smart Zoning System and the Lennox® Communicating Thermostat, the blower motor operates from predetermined minimum - maximum air volumes to satisfy zone requirements.

CONTROLS

9 SureLight® Integrated Furnace Control (Lennox® Communicating)

- Advanced control communicates information about various operating parameters in the furnace to the optional Lennox® Communicating Thermostat to constantly maintain the highest level of comfort, performance and efficiency available
- **Auto Configuration** - On start-up the control automatically sends a description of the unit to the optional Lennox® Communicating Thermostat to automatically configure the number of stages and features available
- Terminals for connecting a conventional heating/cooling thermostat are also provided on the control
- Control also features:
 - Innovative AirFlex™ technology allows custom blower settings based on the application.
 - Precise Comfort Technology™ automatically adjusts blower speed and heat input in increments as small as 1% or as large as needed for greater temperature control
 - Variable-speed combustion air inducer is controlled by the SureLight Control. Prior to ignition, a pre-purge cycle for 15 seconds is initiated. After the main burners are turned off, a post-purge cycle for 20 seconds is run
- **Thermostat Control** - Designed to operate in a variable capacity mode automatically adjusting firing rate based on demand and changing conditions

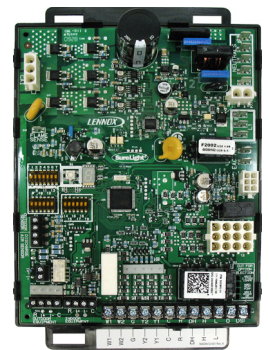

FEATURES

CONTROLS (continued)

NOTE - For optimal performance, the use of a high-quality, digital two-stage thermostat with adjustable settings for first stage/second stage, on/off differentials and adjustable stage timers is recommended.

Furnace Input Staging Options

Thermostat Type	Input Staging Available
Lennox® Communicating Thermostat	Variable Capacity (increments as small as 1%)
	Four Stage (35, 60, 80, 100%)
Two-Stage (Conventional)	Variable Capacity (increments as small as 1%)
	Two-stage (70% and 100%)
Single-Stage (Conventional)	Three-Stage (35%, 70% and 100%)

- **SureLight® Ignition Control** - Ignition control continuously monitors line voltage and maintains the igniter power at a constant level to provide consistent lighting and maximum igniter life
- **Safety Controls** - Flame sensor utilizes flame rectification for safe and reliable operation
- Should flame fail to ignite, control will initiate 4 re-attempts at ignition before locking out unit operation for 60 minutes
- Watchguard type circuit automatically resets ignition controls after one hour of continuous thermostat demand after unit lockout, eliminating nuisance calls for service
- **Display LED** - Seven segment LED displays alpha-numeric information related to diagnostics as well as system operation and status
- Diagnostic codes are held in non-volatile memory, immune from power interruptions
- Holds up to ten diagnostic codes in order of occurrence for recall on demand
- Port on blower door allows for easy viewing

DIP Switch Settings

NOTE - DIP switches settings are not used with Lennox® Communicating Thermostat.

- **Select Thermostat Used** - Single-Stage or Two-Stage
- **Select Operation Mode** - Two-Stage, Three-Stage or Variable Capacity
- Two selectable second stage recognition times (7 and 12 minutes) are available on the control when the furnace is used with a single-stage thermostat
- When used with a two-stage thermostat, furnace will only initiate second stage operation with a second stage thermostat demand
- **Heating Speeds** - A combination of DIP switch settings allow Normal, 7.5% increase, 15% increase, 7.5% decrease or 15% decrease motor speed selection within heating speed selected for fine tuning air volume

- **Cooling Speeds** - A combination of DIP switch settings allow Normal, 10% increase or 10% decrease motor speed selection within cooling speed selected for fine tuning air volume
- See Blower Performance tables
- **Blower Speed Ramping (Cooling Mode)** - DIP switch settings allow one of four blower speed profiles during cooling operation
 - **Profile A (factory setting)** - Motor runs at 50% for 30 seconds, then at 82% for 7-1/2 minutes, then at 100% (if needed) until demand is satisfied. Once demand is met, motor runs at 50% for 30 seconds, then ramps down to stop.
 - **Profile B** - Motor runs at 82% for 7-1/2 minutes and then at 100% (if needed) until demand is satisfied. Once demand is met, motor ramps down to stop.
 - **Profile C** - Motor runs at 100% until demand is satisfied. Once demand is met, motor runs at 100% for 60 seconds, then ramps down to stop.
 - **Profile D** - Motor runs at 100% until demand is satisfied. Once demand is met, motor ramps down to stop.
- **Dehumidification (Active or Humiditrol® Option)** - A jumper on the control must be clipped to enable active dehumidification and/or operation with a Humiditrol® Whole-Home Dehumidification System
 - A humidity controlling thermostat or device is also required
 - During a call for cooling, air volume is automatically reduced, forcing humidity removal by the air conditioner or heat pump system
 - After the humidity has reached the desired set-point the cooling air volume returns to its designed rate
 - A dehumidification signal from the thermostat reduces the cooling cfm to 70% of the requested cooling cfm
- **Dual-Fuel Operation** - A jumper on the control must be clipped to enable operation with a single or two-stage heat pump. The indoor blower is started without delay when a call for heat is received
- **Two-Stage Compressor Operation** - A jumper on the control must be clipped to enable operation with a two-stage compressor
 - The cooling blower speeds for first and second stage cooling will be dictated by the applicable DIP switch settings
- **Lennox System Operations Monitor Connection** - Monitors outdoor unit operation (communicating mode)
- **Blower On Time (Heating)** - Blower on time is fixed at 30 seconds, blower off time is adjustable from 60, 90, 120 and 180 seconds (factory setting - 90 seconds)
- **Blower Off Time (Cooling)** - For air-conditioning applications, blower on time is 2 seconds following thermostat demand for cooling
 - Blower off delay is 30 seconds at 50% of high cool cfm (factory default)
- Controls evaporator humidity by controlling blower and compressor speed on two-stage outdoor units when used with Lennox® Communicating Thermostat

FEATURES

CONTROLS (continued)

- **Continuous Blower Speed** - Adjustable continuous blower speed is a percentage of the high cooling speed selection
- There are four selectable options (via DIP switch settings) of 28%, 38% (default setting), 70% and 100%
- **Accessory Terminals** - Two accessory terminals furnished for additional power supply requirements for 120 volt (less than 1 amp) power humidifiers and powered air cleaners
- One 24 volt humidifier output furnished for non-powered humidifiers
- Control is factory installed in the unit control box

Discharge Air Averaging Sensor

- Shipped with furnace for field installation in the supply air plenum for "enhanced" commissioning at startup (S40 thermostat only) if required
- Measures temperature rise (heating low/high fire mode) and temperature drop (cooling low/high mode)

24 Volt Transformer (40VA)

- Furnished and factory installed on outside of control box
- Circuit breaker (furnished) is wired in series

Field Wiring Make-up Box

- Furnished for line voltage wiring
- Factory installed internally on left side of furnace
- Box may be installed internally on right side of furnace

Optional Accessories

S40 Smart Wi-Fi Thermostat (part of the Lennox® Residential Communicating Control System)

- Recognizes and connects to all Lennox® Communicating products to automatically configure and control the heating/cooling system (based on user-specified settings) for the highest level of comfort, performance and efficiency
- Recognizes model and serial number information for Lennox® Communicating products to simplify system setup
- Lennox Smart Room Sensors, Lennox Wireless Extenders and Lennox Smart Air Quality Monitor can be added to the system
- Smart home automation compatible with Amazon Alexa®, Google Assistant, Control4® and Building36®
- Sends service alerts and reminders
- Lennox Smart Thermostat App features Wi-Fi remote temperature monitoring and adjustment through a home wireless network apps for smartphones or tablets
- Lennox Smart Technician App allows installer to manage systems in the home
- Service Dashboard features online real-time monitoring and advanced diagnostics of installed Lennox® Communicating systems
- Simple easy-to-use touchscreen allows complete system configuration



- Scheduled maintenance alerts, system warnings and troubleshooting are also displayed on thermostat screen
- Easy to read 7 inch high definition color display (measured diagonally)
- Conventional outdoor units (not Lennox® Communicating) can easily be added and controlled by the S40 Thermostat
- Installer setup screens allow quick and simple system configuration without a manual, Installer can also run tests on complete system or individual components for easy maintenance and troubleshooting
- Serial communications bus (RSBus), with less wiring than a conventional heating/cooling system, allows system communication
- Uses standard 4-wire unshielded thermostat wiring
- High Definition Color Display with Subbase and wallplate furnished for easy installation

NOTE - See the Lennox® S40 Thermostat Product Specifications bulletin in the Controls section for more information.

Remote Outdoor Temperature Sensor

- Allows thermostat to display outdoor temperature
- Automatically detected when connected to thermostat

NOTE - Sensor is required for the Enhanced Dehumidification Accessory (EDA).

NOTE - Sensor is furnished as standard with Lennox® Communicating outdoor units, optional for conventional units.



Thermostat

- Thermostat is not furnished with unit
- See Lennox Price Book for selection

Transformer (75VA)

- Recommended when furnace is used with zoning or defrost thermostats and other 24V accessories requiring a higher VA rating
- Circuit breaker (furnished) is wired in series
- Replaces the standard 40VA transformer

CABINET

- Low-profile, narrow width allows easy installation
- Heavy-gauge, cold rolled steel construction
- Pre-painted finish
- Flanges provided on supply air opening for ease of plenum connection or alignment with indoor coil

FEATURES

CABINET (continued)

- 10 • Insulated with foil faced insulation on sides and back of heating compartment and mat faced insulation in blower compartment
- Sealed blower compartment
- Inner blower compartment access panel seals blower compartment from air leakage
- Cabinet door can be removed without any tools
- Complete service access
- Safety interlock switch automatically shuts off power to unit when blower compartment access door is removed
- 11 • Gas piping and electrical inlets are provided in both sides of cabinet

Bottom/Side Return Air Entry

- Upflow/horizontal with bottom return air entry:
 - Remove furnished bottom seal panel from cabinet
- Upflow only with side return-air entry:
 - Corners are marked on either side of cabinet for return air cut-out
- See dimension drawings

NOTE - 60C and 60D size units that require air volumes over 1800 cfm must have one of the following:

- Single side return air and Optional Return Air Base with transition that must accommodate required 20 x 25 x 1 inch air filter to maintain proper velocity
- Bottom return air
- Return air from both sides
- Bottom and one side return air
- See Blower Performance Tables for additional information

Coil Match-Up

- All furnaces exactly match Lennox cased upflow indoor coils and horizontal indoor coils with same letter designation (A, B, C, D) in model number
- No adaptor required
- Engaging holes furnished on cabinet for alignment
- Lennox uncased coils match furnaces without any overhang but require an optional adaptor base or field fabricated transition to match furnace opening
- See coil bulletin for additional information

Low Leakage Cabinet

- All models have less than 2% air leakage
- Meets ANSI/ASHRAE Standard 193-2010 "Method of Test for Determining the Air Tightness of HVAC Equipment"

Optional Accessories

Condensate Drain Heat Cable Kits

- Self-limiting wattage heat cable prevents condensate drain from freezing in unconditioned areas
- Available in 6 or 24 ft. lengths

Horizontal Suspension Kit

- Provides suspension of unit and indoor coil in horizontal applications
- Allows complete service access
- Consists of corner mounted hanging brackets with vibration isolators, return air end support rail and hardware for assembly
- Metal hanging straps must be field provided

Crawl Space Vent Drain Kit

- Allows venting through a crawl space for upflow and horizontal applications
- Includes 2 or 3 inch sanitary tee, 2 inch PVC assembly, PVC boot and clamp
- Kit for Canada is certified to ULC S636

Return Air Base

NOTE - On furnaces with side return air and condensate trap on the same side of the cabinet, a field fabricated transition or Return Air Base is required when using an IAQ product higher than 14-3/16 inches installed next to the unit and serviced from the front. IAQ products higher than 20 inches require a field fabricated transition.

NOTE - Must be used for 60C and 60D size models with air volumes over 1800 cfm in upflow applications when only one side return is required.

- Cabinet is shipped flat for easy field assembly
- Pre-painted steel to match the furnace
- See Dimension Drawing

High Performance Economizer (Commercial Applications Only)

- Designed for applications requiring outdoor air to be utilized in a commercial HVAC system
- Allows the entry of fresh outdoor air for free cooling, reducing the requirement for mechanical cooling
- Heavy gauge galvanized steel cabinet lined with thick fiberglass insulation
- Mixed air sensor, outdoor air sensor and 24VAC transformer furnished
- Approved for California Title 24 building standards
- ASHRAE 90.1-2010 compliant
- See separate Product Specifications bulletin for additional information and available control and sensor options

NOTE - Economizer is not Lennox® communicating compatible.

FEATURES

FILTER (not furnished)

- Filter and provisions for external mounting must be field provided

Optional Accessories

Air Filter and Rack Kit for Horizontal Return Air (End)

Applications

- Washable or vacuum cleanable polyurethane frame type filter and external end return air rack
- Rack has filter door for servicing
- Flanges on rack for duct connection
- Field installed
- See dimension drawing

Air Filter and Rack Kit for Upflow Side Return Air

NOTE - Not for use with Return Air Base

- Washable or vacuum cleanable polyurethane frame type filter and external side return air rack available for field installation
- Available in single and ten pack kits
- Rack has filter door for servicing
- Flanges on rack for duct connection
- Field installs on either side of unit cabinet
- See dimension drawing

REFRIGERATION DETECTION SYSTEM (RDS)

Optional Accessories

Refrigerant Detection System (RDS) Coil Sensor Kit

- Complies with UL 60335-2-40 approved standard
- Required for field installation for all systems using R-454B refrigerant if sensor is not furnished with coil
- Consists of Refrigerant Detection System (RDS) sensor, lineset sleeves, mounting brackets and A2L labeling
- Sensor ensures safe operation for systems equipped with R-454B refrigerant
- Sensor will detect any refrigerant leaks if they occur

Refrigerant Detection System (RDS) Blower Control Board Communicating Blower Control Board (Universal)

- Communicating Blower Control Board and Sensor can be used universally with any Lennox® communicating furnace or any non-communicating 24 volt furnace

Non-Communicating Blower Control Board

- Non-Communicating Blower Control Board and Sensor can be used with any non-communicating 24 volt furnace

Standard Features

- Complies with UL 60335-2-40 approved standard
- Required for all systems using R-454B refrigerant
- Connects to the RDS sensor furnished with the RDS Coil Sensor Kit
- Supports up to two RDS Sensors (factory setting)
- Used as an interface between indoor unit and thermostat to control system in case of a refrigerant leak

- Ensures safe operation for systems equipped with R-454B refrigerant
- If a leak is detected, the refrigerant detection system will stop compressor and/or heating operation and operate the blower to reduce concentrations in the conditioned space
- Once safe levels are reached the HVAC system will resume normal operation
- Multi-color LED for system status and as an aid in troubleshooting
 - Flashing LED codes for system status (Green/Blue) and diagnosing Sensor errors (Red)
- Alarm relay can trigger an external alarm if a leak is detected
- Zone relay opens all zone dampers (if part of a zoning system) if a leak is detected
- Power is disabled to non-communicating thermostats to prevent demand if a leak is detected
- On system start-up blower will run for five minutes and any thermostat demands are disabled
- Dimensions (H x W x D): 7-7/16 x 7-7/16 x 2-1/2 (189 x 189 x 127 mm)

NOTE - See Refrigerant Detection System (RDS) Components Table on page <?>.

See the CK40 Indoor Coil Product Specifications bulletins for more information.

Refer to the Installation Instructions for additional information.

SPECIFICATIONS

Gas	Model No.	SLP99UH070XV36B	SLP99UH090XV36C	SLP99UH090XV48C	
Heating Performance	¹ AFUE	98.1%	98.1%	98.2%	
Maximum	Input - Btuh	66,000	88,000	88,000	
	Output - Btuh	64,000	86,000	85,000	
	Temperature rise range - °F	50 - 80	60 - 90	50 - 80	
	Gas Manifold Pressure (in. w.g.) Nat. Gas / LPG/Propane	3.5 / 10.0	3.5 / 10.0	3.5 / 10.0	
	Minimum	Input - Btuh	23,000	31,000	31,000
		Output - Btuh	22,000	30,000	30,000
		Temperature rise range - °F	35 - 65	35 - 65	35 - 65
		Gas Manifold Pressure (in. w.g.) Nat. Gas / LPG/Propane	0.5 / 1.5	0.5 / 1.5	0.5 / 1.5
		High static - in. w.g.	0.8	0.8	0.8
	Connections in.	Intake / ² Exhaust Pipe (PVC)	2 / 2	2 / 2	2 / 2
Gas pipe size IPS		1/2	1/2	1/2	
Condensate Drain Trap (PVC pipe) - i.d.		3/4	3/4	3/4	
with furnished 90° street elbow with field supplied (PVC coupling) - o.d.		3/4 slip x 3/4 Mipt 3/4 slip x 3/4 MPT	3/4 slip x 3/4 Mipt 3/4 slip x 3/4 MPT	3/4 slip x 3/4 Mipt 3/4 slip x 3/4 MPT	
Indoor Blower	Wheel nominal diameter x width - in.	10 x 9	10 x 9	11 x 11	
	Motor output - hp	1/2	1/2	3/4	
	Tons of add-on cooling	2 - 3	2 - 3.5	2.5 - 4	
	Air Volume Range - cfm	339 - 1365	520 - 1360	528 - 1770	
Electrical Data	Voltage (Maximum Amps)	120 volts - 60 Hertz - 1 phase			
	Blower motor full load amps	7.7	7.7	10.1	
	Maximum overcurrent protection	15	15	15	
Shipping Data	lbs. - 1 package	139	156	166	

NOTE - Filters and provisions for mounting are not furnished and must be field provided.

¹ Annual Fuel Utilization Efficiency based on DOE test procedures and according to FTC labeling regulations. Isolated combustion system rating for non-weatherized furnaces.

² 2 in. Rubber Flue Coupling is furnished for exhaust pipe connection to unit.

SPECIFICATIONS

Gas	Model No.	SLP99UH090XV60C	SLP99UH110XV60C	SLP99UH135XV60D	
Heating Performance	¹ AFUE	99%	98.1%	98.4%	
Maximum	Input - Btuh	88,000	110,000	132,000	
	Output - Btuh	87,000	106,000	128,000	
	Temperature rise range - °F	50 - 80	50 - 80	55 - 85	
	Gas Manifold Pressure (in. w.g.) Nat. Gas / LPG/Propane	3.5 / 10.0	3.5 / 10.0	3.5 / 10.0	
	Minimum	Input - Btuh	31,000	39,000	46,000
		Output - Btuh	30,000	38,000	45,000
		Temperature rise range - °F	25 - 55	35 - 65	35 - 65
		Gas Manifold Pressure (in. w.g.) Nat. Gas / LPG/Propane	0.5 / 1.5	0.5 / 1.5	0.5 / 1.5
		High static - in. w.g.	0.8	0.8	0.8
	Connections in.	Intake / ² Exhaust Pipe (PVC)	2 / 2	2 / 2	2 / 2
Gas pipe size IPS		1/2	1/2	1/2	
Condensate Drain Trap (PVC pipe) - i.d.		3/4	3/4	3/4	
with furnished 90° street elbow with field supplied (PVC coupling) - o.d.		3/4 slip x 3/4 Mipt 3/4 slip x 3/4 MPT	3/4 slip x 3/4 Mipt 3/4 slip x 3/4 MPT	3/4 slip x 3/4 Mipt 3/4 slip x 3/4 MPT	
Indoor Blower	Wheel nominal diameter x width - in.	11 x 11	11 x 11	11 x 11	
	Motor output - hp	1	1	1	
	Tons of add-on cooling	3 - 5	3 - 5	3.5 - 5	
	Air Volume Range - cfm	530 - 2195	580 - 2125	646 - 2190	
Electrical Data	Voltage (Maximum Amps)	120 volts - 60 Hertz - 1 phase			
	Blower motor full load amps	12.8	12.8	12.8	
	Maximum overcurrent protection	20	20	20	
Shipping Data	lbs. - 1 package	166	176	191	

NOTE - Filters and provisions for mounting are not furnished and must be field provided.

¹ Annual Fuel Utilization Efficiency based on DOE test procedures and according to FTC labeling regulations. Isolated combustion system rating for non-weatherized furnaces.

² 2 in. Rubber Flue Coupling is furnished for exhaust pipe connection to unit.

OPTIONAL ACCESSORIES - ORDER SEPARATELY

NOTE - FURNACES CANNOT BE TWINNED!

		"B" Width Models	"C" Width Models	"D" Width Models	
CABINET ACCESSORIES					
Horizontal Suspension Kit - Horizontal only		51W10	51W10	51W10	
Return Air Base - Upflow only		50W98	50W99	51W00	
High Performance Economizer (Commercial Only)		10U53	10U53	10U53	
CONDENSATE DRAIN KITS					
Condensate Drain Heat Cable	6 ft.	26K68	26K68	26K68	
	24 ft.	26K69	26K69	26K69	
Crawl Space Vent Drain Kit	US	51W18	51W18	51W18	
	Canada	15Z70	15Z70	15Z70	
CONTROLS					
S40 Smart Wi-Fi Thermostat		22V24	22V24	22V24	
¹ Remote Outdoor Air Temperature Sensor		X2658	X2658	X2658	
Transformer (75VA)		27J32	27J32	27J32	
FILTER KITS					
² Air Filter and Rack Kit	Horizontal (end)	Size of filter - in.	87L96	87L97	87L98
		18 x 25 x 1	20 x 25 x 1	25 x 25 x 1	
	Side Return	Single	44J22	44J22	44J22
		Ten Pack	66K63	66K63	66K63
		Size of filter - in.	16 x 25 x 1	16 x 25 x 1	16 x 25 x 1
TERMINATION KITS					
Direct Vent Applications Only. See Installation Instructions for specific venting information.					
Direct Vent	Concentric	US - 2 in.	71M80	69M29	---
		3 in.	---	60L46	60L46
		Canada - 2 in.	44W92	44W92	---
		3 in.	---	44W93	44W93
	Flush-Mount	US - 2, 2-1/2 or 3 in.	51W11	51W11	51W11
		Canada - 2, 2-1/2 or 3 in.	51W12	51W12	51W12
	Wall - Close Couple	US - 2 in.	22G44	---	---
		3 in.	44J40	44J40	44J40
	Wall - Close Couple WTK	Canada - 2 in.	30G28	---	---
		3 in.	81J20	81J20	81J20
	Roof Termination Flashing Kit (no vent pipe - 2 flashings)	2 in.	15F75	15F75	---
		3 in.	44J41	44J41	44J41

¹ Remote Outdoor Temperature Sensor is used with conventional (non-Lennox® Communicating) outdoor units (sensor is furnished with Lennox® Communicating outdoor units). Allows the thermostat to display outdoor temperature. Required in dual-fuel and EDA applications.

² Cleanable polyurethane frame type filter.

NOTE - Termination Kits (44W92, 44W93, 30G28, 51W12, 81J20) and Crawl Space Vent Drain Kit (15Z70) are certified to ULC S636 standard for use in Canada only.

GAS HEAT ACCESSORIES

Input	High Altitude Pressure Switch Kit	Natural Gas to LPG/Propane Kit	Natural Gas to LPG/Propane Kit	High Altitude Conversion Kit Natural Gas	LPG/Propane to Natural Gas Kit	Muffler (US Only)
	7501 - 10,000 ft.	0 - 4500 ft.	4501 - 10,000 ft.	4501 - 10,000 ft.	0 - 7500 ft.	
070	14T65	65W77	65W77	---	70W87	15Y66 (2-inch)
090XV36C/48C	14T65	65W77	65W77	---	70W87	15Y66 (2-inch)
090XV60C	20A87	20A26	20A88	20A89	---	15Y66 (2-inch)
110	14T65	65W77	65W77	---	70W87	¹ 15Y66 (2-inch) 16A56 (3-inch)
135	14T65	65W77	65W77	---	70W87	16A56 (3-inch)

¹ Two-inch diameter muffler (15Y66) is optional for 110 input model with a maximum vent pipe length of up to 29 ft.
Three-inch diameter muffler (16A56) is optional for 110 input model with a minimum vent pipe length of 30 ft.

REFRIGERANT DETECTION SYSTEM (RDS) COMPONENTS

Description	Order No.	
Refrigerant Detection System (RDS) Coil Sensor Kit	26Z69	
Refrigerant Detection System (RDS) Blower Control Board	Any Lennox® Communicating Furnace <u>or</u> any Non-Communicating 24V Furnace (Universal)	27A03
	Any Non-Communicating 24V Furnace	27A02

NOTE - Communicating Blower Control Board and Sensor can be used universally with Lennox® communicating furnace or any non-communicating 24 volt furnace.
Non-Communicating Blower Control Board and Sensor can be used with any non-communicating 24 volt furnace.

OUTDOOR TERMINATION KIT USAGE

Input Size	Vent Pipe Diameter (in.)	Standard Terminations				Concentric Terminations		
		Flush Mount Kit	Wall Kit		Field Fabricated Exhaust Accelerator Size Required	Concentric Kit		
			2 inch	3 inch		1-1/2 inch	2 inch	3 inch
			51W11 (US) 5 51W12 (CA)	22G44 (US) 5 30G28 (CA)		44J40 (US) 5 81J20 (CA)	71M80 (US) 5 44W92 (CA)	69M29 (US) 5 44W92 (CA)
070	1 1-1/2	4 YES	YES	2 YES	1-1/2 in.	3 YES		
	2	4 YES	YES	2 YES	1-1/2 in.	3 YES	---	---
	2-1/2	4 YES	YES	2 YES	1-1/2 in.	3 YES	---	---
	3	4 YES	YES	2 YES	1-1/2 in.	3 YES	---	---
090	2	4 YES	---	YES	2 in.	---	YES	YES
	2-1/2	4 YES	---	YES	2 in.	---	YES	YES
	3	4 YES	---	YES	2 in.	---	YES	YES
110	2	YES	---	YES	2 in.	---	YES	YES
	2-1/2	YES	---	YES	2 in.	---	YES	YES
	3	YES	---	YES	2 in.	---	YES	YES
135	3	YES	---	YES	2 in.	---	---	YES

NOTE - Standard Terminations do not include any vent pipe or elbows external to the structure.

Any vent pipe or elbows external to the structure must be included in total vent length calculations. See Vent Length Tables.

NOTE - When using 1-1/2 inch piping with Concentric Kit or Flush Mount Kit pipe must be transitioned to 2 inch pipe.

¹ Requires 2 inch to 1-1/2 inch reducer, must be field provided.

² Requires field provided 1-1/2 in. outdoor exhaust accelerator.

³ Concentric Kits **71M80** and **44W92** include 1-1/2 in. outdoor exhaust accelerator, required when used with 045 and 070 input models. Accelerator is not used with 090, 110, 135 input models.

⁴ Flush Mount Kit **51W11** and **51W12** includes 1-1/2 in. outdoor exhaust accelerator, required when used with 045, 070 and 090 input models. Accelerator is not used with 110 or 135 input models.

⁵ Termination Kits **30G28**, **44W92**, **44W93**, **51W12** and **81J20** are certified to ULC S636 standard for use in Canada only.

VENT LENGTHS - UNINSULATED EXHAUST PIPE IN UNCONDITIONED SPACE

¹ Winter Design Temperatures	Vent Pipe Diameter	Unit Input Size							
		070		090		110		135	
		Maximum Uninsulated Exhaust Vent Length (ft.)							
		PVC	PolyPro InnoFlue	PVC	PolyPro InnoFlue	PVC	PolyPro InnoFlue	PVC	PolyPro InnoFlue
32 to 21°F	1-1/2 inch	N/A	N/A	N/A	N/A	N/A	N/A	N/A	N/A
	2 in.	11	9	14	12	18	15	N/A	N/A
	2-1/2 in.	7	N/A	10	N/A	12	N/A	N/A	N/A
	3 in.	N/A	N/A	6	6	8	8	13	13
20 to 1°F	1-1/2 inch	N/A	N/A	N/A	N/A	N/A	N/A	N/A	N/A
	2 in.	N/A	N/A	6	4	8	6	N/A	N/A
	2-1/2 in.	N/A	N/A	N/A	N/A	N/A	N/A	N/A	N/A
	3 in.	N/A	N/A	N/A	N/A	N/A	N/A	N/A	N/A
0 to -20°F	1-1/2 inch	N/A	N/A	N/A	N/A	N/A	N/A	N/A	N/A
	2 in.	N/A	N/A	N/A	N/A	N/A	N/A	N/A	N/A
	2-1/2 in.	N/A	N/A	N/A	N/A	N/A	N/A	N/A	N/A
	3 in.	N/A	N/A	N/A	N/A	N/A	N/A	N/A	N/A

NOTE - Lengths shown are equivalent pipe lengths.

Concentric terminations are equivalent to 5 ft. of straight pipe and should be included when measuring total pipe length.

Elbows are equivalent to 5 ft. of straight pipe and should be included when measuring total pipe length.

¹ Refer to 99% Minimum Design Temperature table provided in the current edition of ASHRAE Handbook-Fundamentals.

PolyPro® poly-propylene vent pipe is a registered trademark of DuraVent®.

Innoflue® is a registered trademark of Centrotherm Eco Systems.

VENT LENGTHS

STANDARD TERMINATION AT ELEVATION 0 - 7500 ft.

Pipe Size		1-1/2 in.				2 in.				2-1/2 in.				3 in.			
Input		070	090	110	135	070	090	110	135	070	090	110	135	070	090	110	135
No. of 90 ELL	1	20	N/A	N/A	N/A	91	69	14	N/A	140	93	43	N/A	162	143	118	114
	2	15	N/A	N/A	N/A	86	64	9	N/A	135	88	38	N/A	157	138	113	109
	3	10	N/A	N/A	N/A	81	59	N/A	N/A	130	83	33	N/A	152	133	108	104
	4	N/A	N/A	N/A	N/A	76	54	N/A	N/A	125	78	28	N/A	147	128	103	99
	5	N/A	N/A	N/A	N/A	71	49	N/A	N/A	120	73	23	N/A	142	123	98	94
	6	N/A	N/A	N/A	N/A	66	44	N/A	N/A	115	68	18	N/A	137	118	93	89
	7	N/A	N/A	N/A	N/A	61	39	N/A	N/A	110	63	13	N/A	132	113	88	84
	8	N/A	N/A	N/A	N/A	56	34	N/A	N/A	105	58	N/A	N/A	127	108	83	79
	9	N/A	N/A	N/A	N/A	51	29	N/A	N/A	100	53	N/A	N/A	122	103	78	74
	10	N/A	N/A	N/A	N/A	46	24	N/A	N/A	95	48	N/A	N/A	117	98	73	69

STANDARD TERMINATION AT ELEVATION 7501 - 10,000 ft.

Pipe Size		1-1/2 in.				2 in.				2-1/2 in.				3 in.			
Input		070	090	110	135	070	090	110	135	070	090	110	135	070	090	110	135
No. of 90 ELL	1	12	N/A	N/A	N/A	66	44	N/A	N/A	115	68	N/A	N/A	137	118	93	89
	2	7	N/A	N/A	N/A	61	39	N/A	N/A	110	63	N/A	N/A	132	113	88	84
	3	N/A	N/A	N/A	N/A	56	34	N/A	N/A	105	58	N/A	N/A	127	108	83	79
	4	N/A	N/A	N/A	N/A	51	29	N/A	N/A	100	53	N/A	N/A	122	103	78	74
	5	N/A	N/A	N/A	N/A	46	24	N/A	N/A	95	48	N/A	N/A	117	98	73	69
	6	N/A	N/A	N/A	N/A	41	19	N/A	N/A	90	43	N/A	N/A	112	93	68	64
	7	N/A	N/A	N/A	N/A	36	14	N/A	N/A	85	38	N/A	N/A	107	88	63	59
	8	N/A	N/A	N/A	N/A	31	N/A	N/A	N/A	80	33	N/A	N/A	102	83	58	54
	9	N/A	N/A	N/A	N/A	26	N/A	N/A	N/A	75	28	N/A	N/A	97	78	53	49
	10	N/A	N/A	N/A	N/A	21	N/A	N/A	N/A	70	23	N/A	N/A	92	73	48	44

CONCENTRIC TERMINATION ELEVATION 0 - 7500 ft.

Pipe Size		1-1/2 in.				2 in.				2-1/2 in.				3 in.			
Input		070	090	110	135	070	090	110	135	070	090	110	135	070	090	110	135
No. of 90 ELL	1	15	N/A	N/A	N/A	83	67	12	N/A	130	89	39	N/A	146	139	114	105
	2	10	N/A	N/A	N/A	78	62	7	N/A	125	84	34	N/A	141	134	109	100
	3	N/A	N/A	N/A	N/A	73	57	N/A	N/A	120	79	29	N/A	136	129	104	95
	4	N/A	N/A	N/A	N/A	68	52	N/A	N/A	115	74	24	N/A	131	124	99	90
	5	N/A	N/A	N/A	N/A	63	47	N/A	N/A	110	69	19	N/A	126	119	94	85
	6	N/A	N/A	N/A	N/A	58	42	N/A	N/A	105	64	14	N/A	121	114	89	80
	7	N/A	N/A	N/A	N/A	53	37	N/A	N/A	100	59	N/A	N/A	116	109	84	75
	8	N/A	N/A	N/A	N/A	48	32	N/A	N/A	95	54	N/A	N/A	111	104	79	70
	9	N/A	N/A	N/A	N/A	43	27	N/A	N/A	90	49	N/A	N/A	106	99	74	65
	10	N/A	N/A	N/A	N/A	38	22	N/A	N/A	85	44	N/A	N/A	101	94	69	60

CONCENTRIC TERMINATION ELEVATION 7501 - 10,000 ft.

Pipe Size		1-1/2 in.				2 in.				2-1/2 in.				3 in.			
Input		070	090	110	135	070	090	110	135	070	090	110	135	070	090	110	135
No. of 90 ELL	1	10	N/A	N/A	N/A	58	42	N/A	N/A	105	64	N/A	N/A	121	114	89	80
	2	N/A	N/A	N/A	N/A	53	37	N/A	N/A	100	59	N/A	N/A	116	109	84	75
	3	N/A	N/A	N/A	N/A	48	32	N/A	N/A	95	54	N/A	N/A	111	104	79	70
	4	N/A	N/A	N/A	N/A	43	27	N/A	N/A	90	49	N/A	N/A	106	99	74	65
	5	N/A	N/A	N/A	N/A	38	22	N/A	N/A	85	44	N/A	N/A	101	94	69	60
	6	N/A	N/A	N/A	N/A	33	17	N/A	N/A	80	39	N/A	N/A	96	89	64	55
	7	N/A	N/A	N/A	N/A	28	12	N/A	N/A	75	34	N/A	N/A	91	84	59	50
	8	N/A	N/A	N/A	N/A	23	N/A	N/A	N/A	70	29	N/A	N/A	86	79	54	45
	9	N/A	N/A	N/A	N/A	18	N/A	N/A	N/A	65	24	N/A	N/A	81	74	49	40
	10	N/A	N/A	N/A	N/A	13	N/A	N/A	N/A	60	19	N/A	N/A	76	69	44	35

INSTALLATION CLEARANCES

Sides	¹ 0 inches (0 mm)
Rear	0 inches (0 mm)
Top/Plenum	1 inch (25 mm)
Front	0 inches (0 mm)
Front (service/alcove)	24 inches (610 mm)
Floor	² Combustible

NOTE - Air for combustion must conform to the methods outlined in the National Fuel Gas Code (NFPA 54/ANSI-Z223.1) or the National Standard of Canada CAN/CSA-B149.1 "Natural Gas and Propane Installation Code".

NOTE - In the U.S. flue sizing must conform to the methods outlined in the current National Fuel Gas Code (NFPA 54/ANSI-Z223.1) or applicable provisions of local building codes. In Canada flue sizing must conform to the methods outlined in National Standard of Canada CAN/CSA-B149.1.

¹ Allow proper clearances to accommodate condensate trap and vent pipe installation.

² Do not install the furnace directly on carpeting, tile, or other combustible materials other than wood flooring.

DIMENSIONS - UNIT - UPFLOW POSITION

¹ NOTE - 60C and 60D size units that require air volumes over 1800 cfm must have one of the following:

1. Single side return air and Optional Return Air Base with transition that must accommodate required 20 x 25 x 1 inch (508 x 635 x 25 mm) air filter to maintain proper velocity.
 2. Bottom return air.
 3. Return air from both sides.
 4. Bottom and one side return air.
- See Blower Performance Tables for additional information.

² Optional Side Return Air Filter Kit is not for use with the Optional Return Air Base.

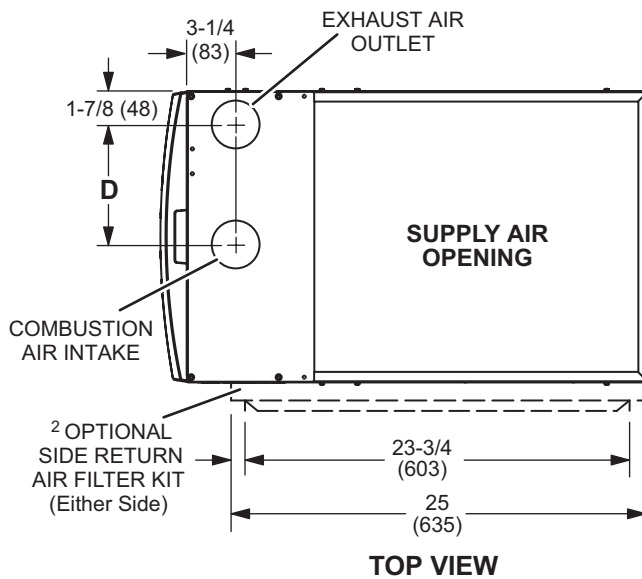

Flue Condensate Trap Assembly

Furnished for external field installation on either side of unit. (See installation instructions for additional information.)

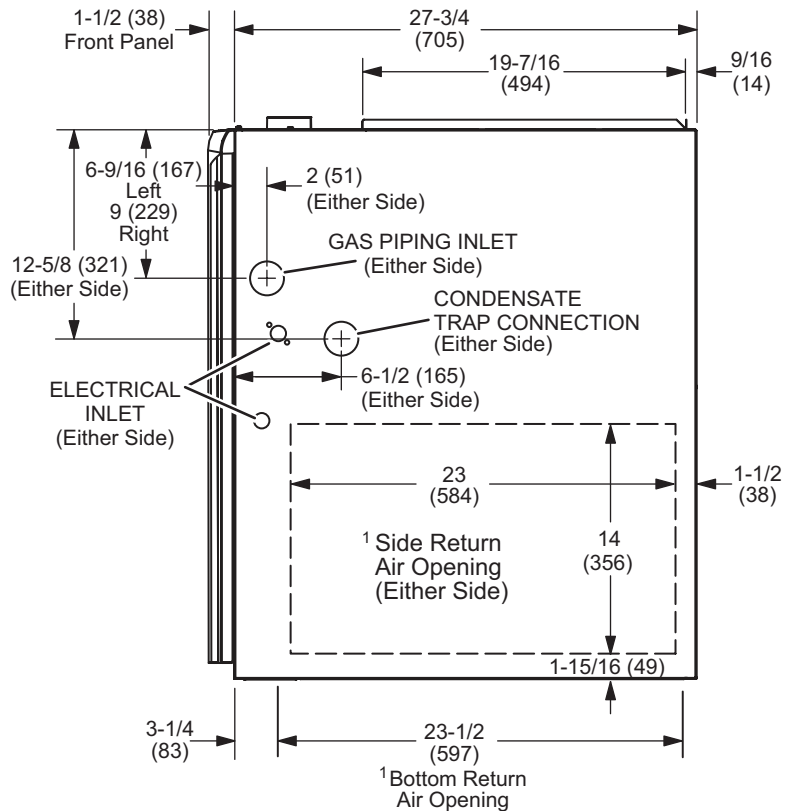
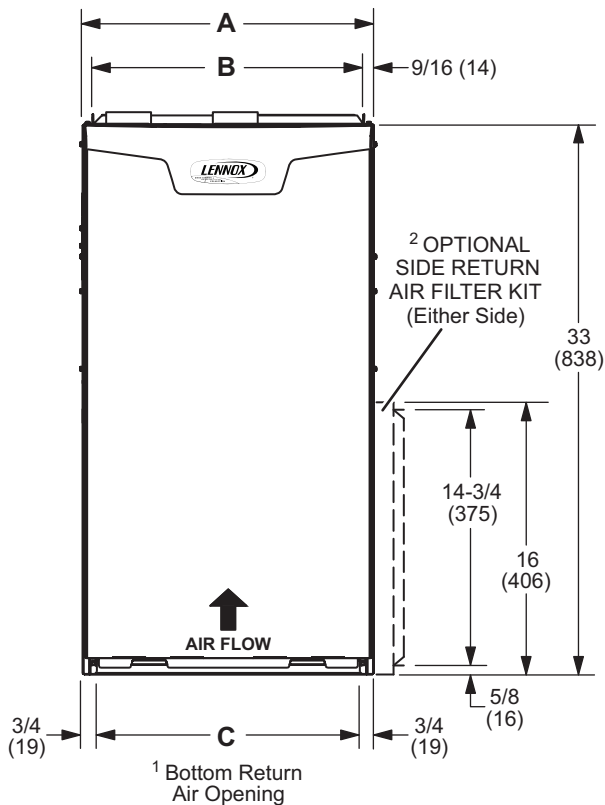
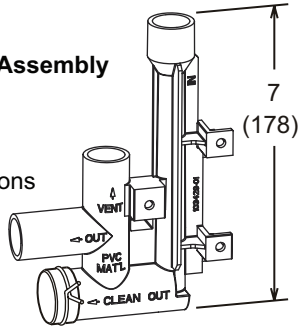

FRONT VIEW

SIDE VIEW

Model No.	A		B		C		D	
	in.	mm	in.	mm	in.	mm	in.	mm
SLP99UH070XV36B	17-1/2	446	16-3/8	416	16	406	7-5/8	194
SLP99UH090XV36C	21	533	19-7/8	505	19-1/2	495	9-3/8	238
SLP99UH090XV48C								
SLP99UH090XV60C								
SLP99UH110XV60C	24-1/2	622	23-3/8	594	23	584	11-1/8	283
SLP99UH135XV60D								

DIMENSIONS - UNIT - HORIZONTAL POSITION

LEFT-HAND AIR DISCHARGE

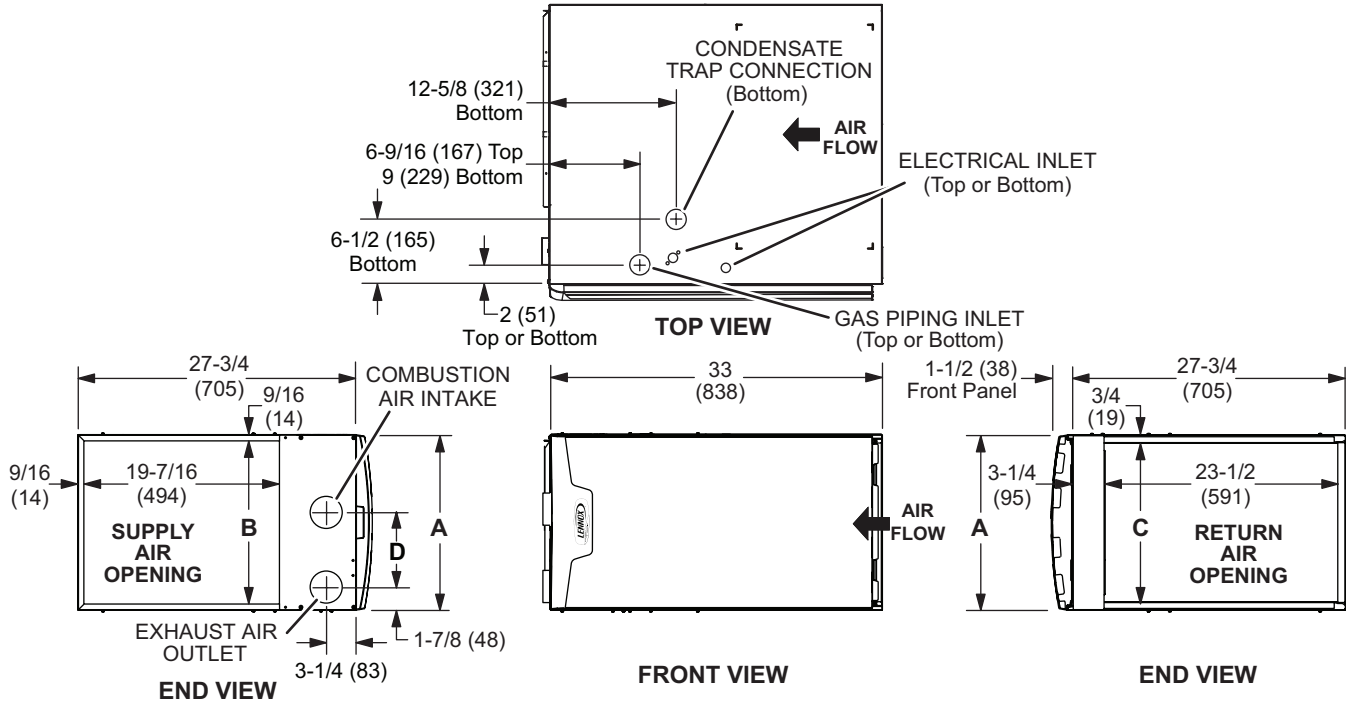

RIGHT-HAND AIR DISCHARGE

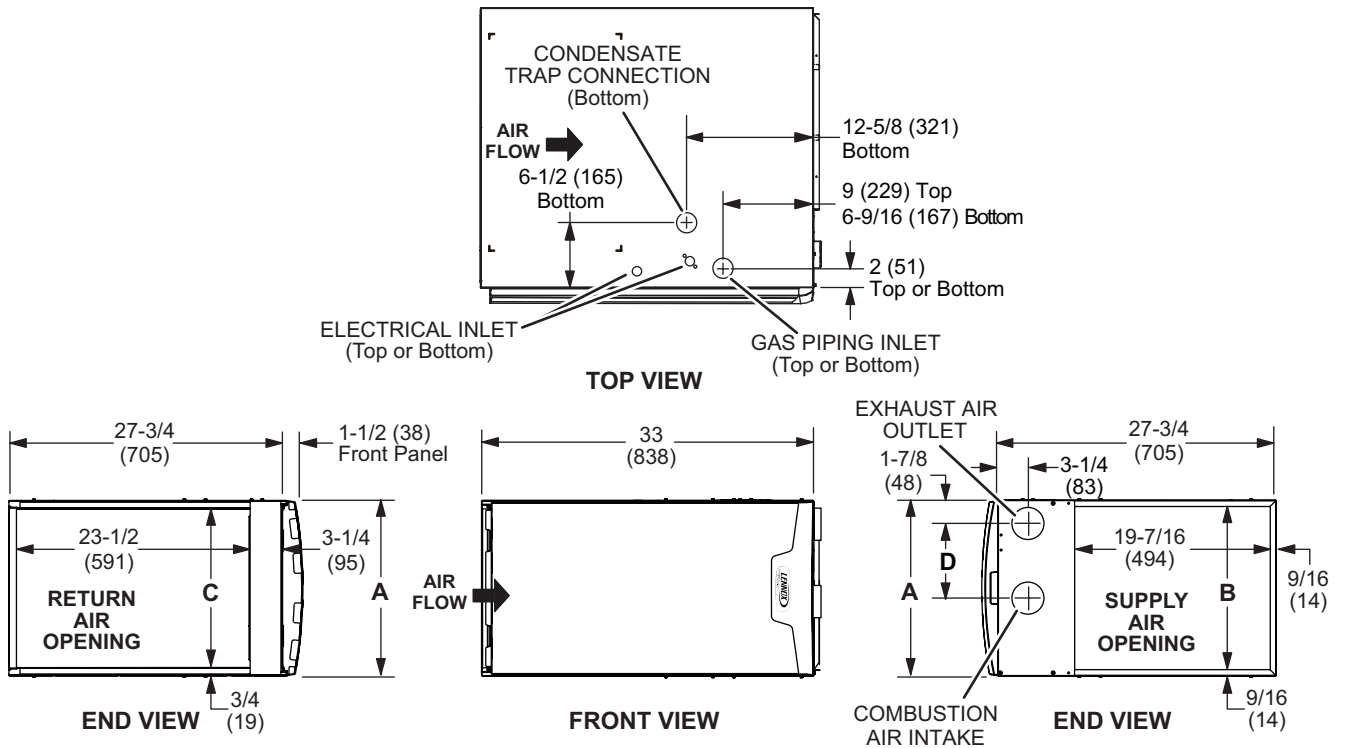

Model No.	A		B		C		D	
	in.	mm	in.	mm	in.	mm	in.	mm
SLP99UH070XV36B	17-1/2	446	16-3/8	416	16	406	7-5/8	194
SLP99UH090XV36C	21	533	19-7/8	505	19-1/2	495	9-3/8	238
SLP99UH090XV48C								
SLP99UH090XV60C								
SLP99UH110XV60C								
SLP99UH135XV60D	24-1/2	622	23-3/8	594	23	584	11-1/8	283

DIMENSIONS - OPTIONAL ACCESSORIES

HORIZONTAL (END) FILTER KIT

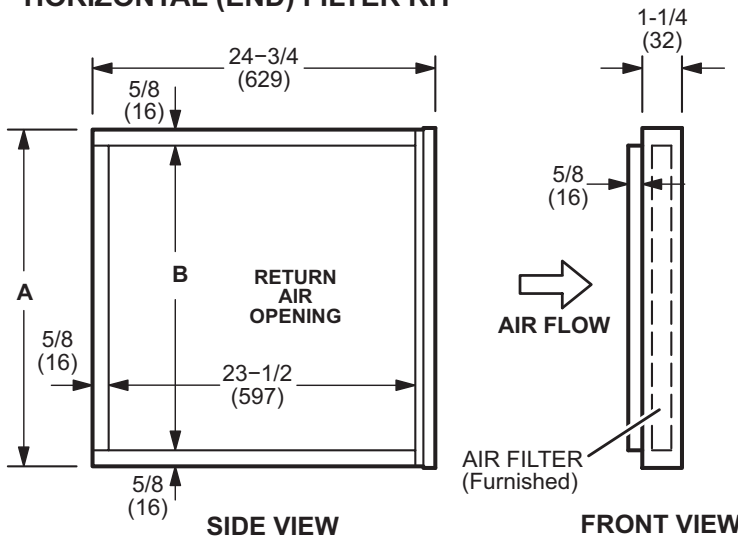

Furnace Cabinet Width	Catalog Number	A		B	
		in.	mm	in.	mm
B	87L96	18	457	16-3/4	425
C	87L97	21	533	18-3/4	476
D	87L98	25	635	23-3/4	603

OPTIONAL RETURN AIR BASE (Upflow Applications Only - For use with B, C and D cabinets)

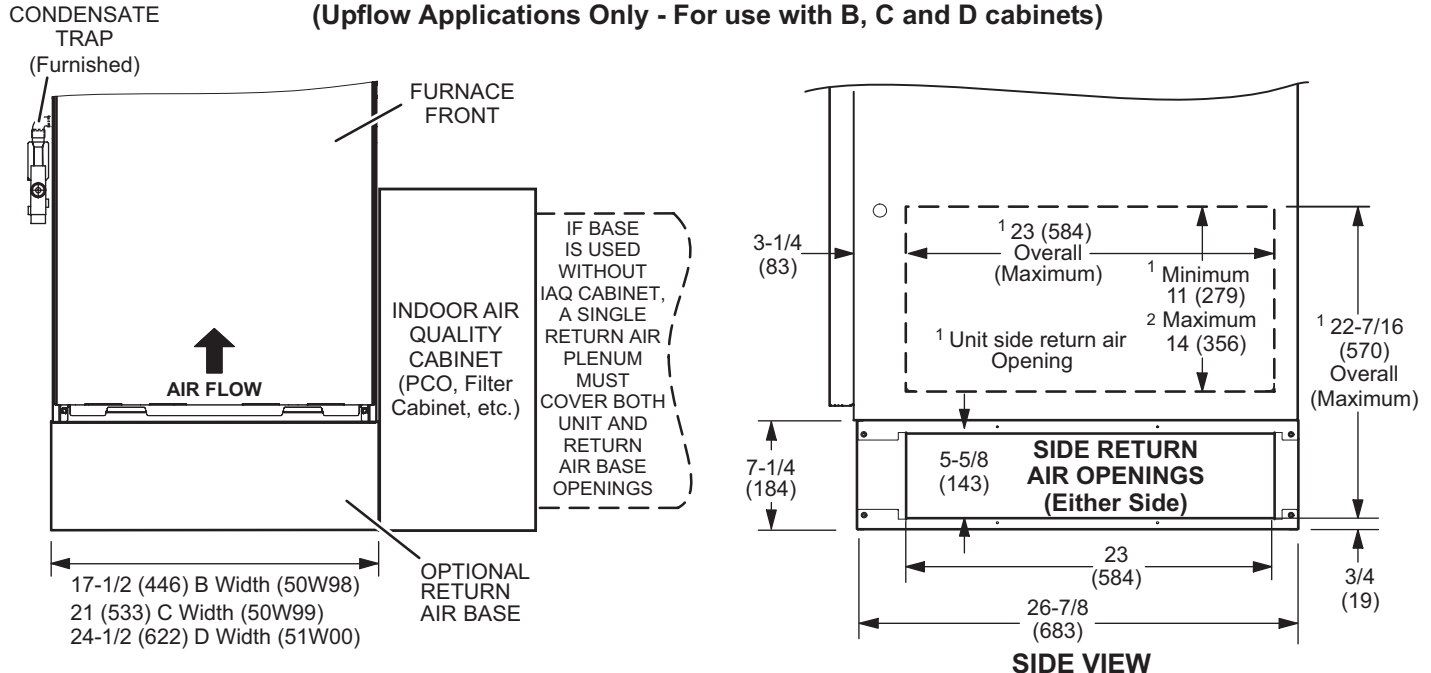

NOTE- Optional Side Return Air Filter Kits are not for use with Optional Return Air Base.

- ¹ Both the unit return air opening and the base return air opening must be covered by a single plenum or IAQ cabinet. Minimum unit side return air opening dimensions for units requiring 1800 cfm or more of air (W x H): 23 x 11 in. (584 x 279 mm). The opening can be cut as needed to accommodate plenum or IAQ cabinet while maintaining dimensions shown. Side return air openings must be cut in the field. There are cutting guides stenciled on the cabinet for the side return air opening. The size of the opening must not extend beyond the markings on the furnace cabinet.

- ² To minimize pressure drop, the largest opening height possible, up to 14 in. (356 mm), is preferred.

DIMENSIONS - FURNACE/COIL COMBINED DIMENSIONS

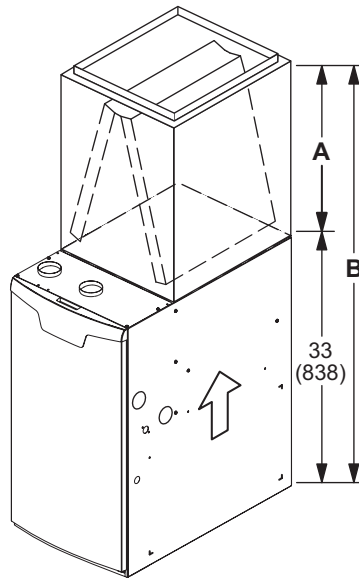

UPFLOW POSITION - CASED

Model		A		B	
CK40CT	C35/CX35	in.	mm	in.	mm
CK40CT-18/24B	C35/CX35-18/24B	16-1/2	419	49-1/2	1257
CK40CT-24B	C35/CX35-24B	18-1/2	470	51-1/2	1308
CK40CT-30B	C35/CX35-30B	22-1/2	572	55-1/2	1410
CK40CT-30/36B	C35/CX35-30/36B	24-1/2	622	57-1/2	1461
CK40CT-30/36C	C35/CX35-30/36C				
CK40CT-36B	C35/CX35-36B	24-1/2	622	57-1/2	1461
CK40CT-48B	C35/CX35-48B	27-1/2	699	60-1/2	1537
CK40CT-48C	C35/CX35-48C				
CK40CT-49C	C35/CX35-49C	29-1/2	749	62-1/2	1588
CK40CT-50/60C	C35/CX35-50/60C	27-1/2	699	60-1/2	1537
CK40CT-60C	CX35-60C	31-1/2	800	64-1/2	1638
CK40CT-60D	CX35-60D	29-1/2	749	62-1/2	1588

UPFLOW POSITION - UNCASED

Model		A		B	
CK40UT	C35	in.	mm	in.	mm
CK40UT-18/24B	C35-18/24B	14-1/8	359	47-1/8	1197
CK40UT-24B	C35-24B	16-3/8	416	49-3/8	1254
CK40UT-30B	C35-30B	20-3/4	527	53-3/4	1365
CK40UT-30/36B	C35-30/36B	22-1/4	565	55-1/4	1403
CK40UT-30/36C	C35-30/36C				
CK40UT-36B	C35-36B	22-3/8	568	55-3/8	1407
CK40UT-48B	C35-48B	26-1/4	667	59-1/4	1505
CK40UT-48C	C35-48C				
CK40UT-49C	C35-49C	28-1/2	724	61-1/2	1562
CK40UT-50/60C	C35-50/60C	25-7/8	657	58-7/8	1495
CK40UT-60C	C35-60C	30-5/8	778	63-5/8	1616
CK40UT-60D	C35-60D	28	711	61	1549

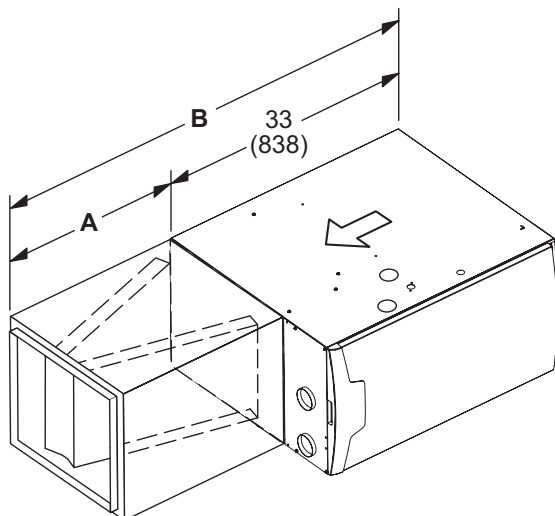

HORIZONTAL POSITION

Model		A		B	
CK40HT	CHX35	in.	mm	in.	mm
CK40HT-24B	CHX35-24B	26-1/2	673	59-1/2	1511
CK40HT-30B	CHX35-30B				
CK40HT-36B	CHX35-36B				
CK40HT-36C	CHX35-36C				
CK40HT-42C	CHX35-42C				
CK40HT-48C	CHX35-48C				
CK40CT-42B	CHX35-42B	31-1/2	880	64-1/2	1638
CK40CT-48B	CHX35-48B				
CK40CT-51	CHX35-51				
CK40CT-60D	CHX35-60D				

DIMENSIONS - OPTIONAL ACCESSORIES - VENTING

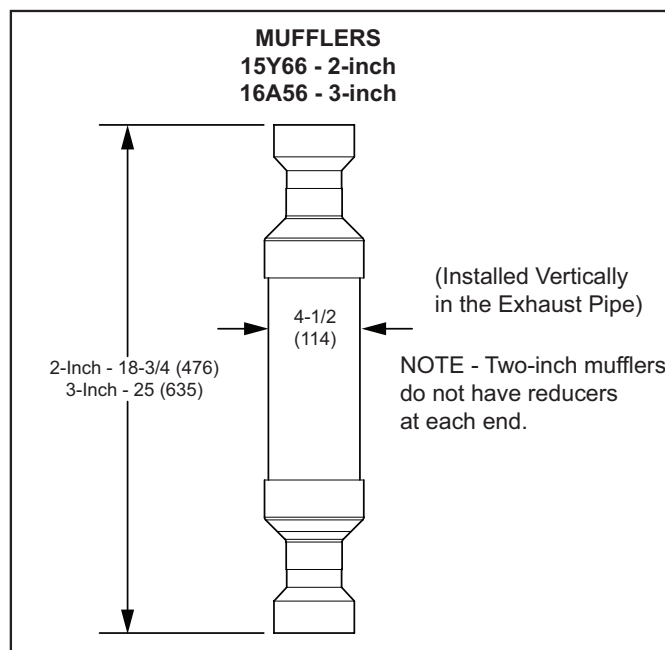
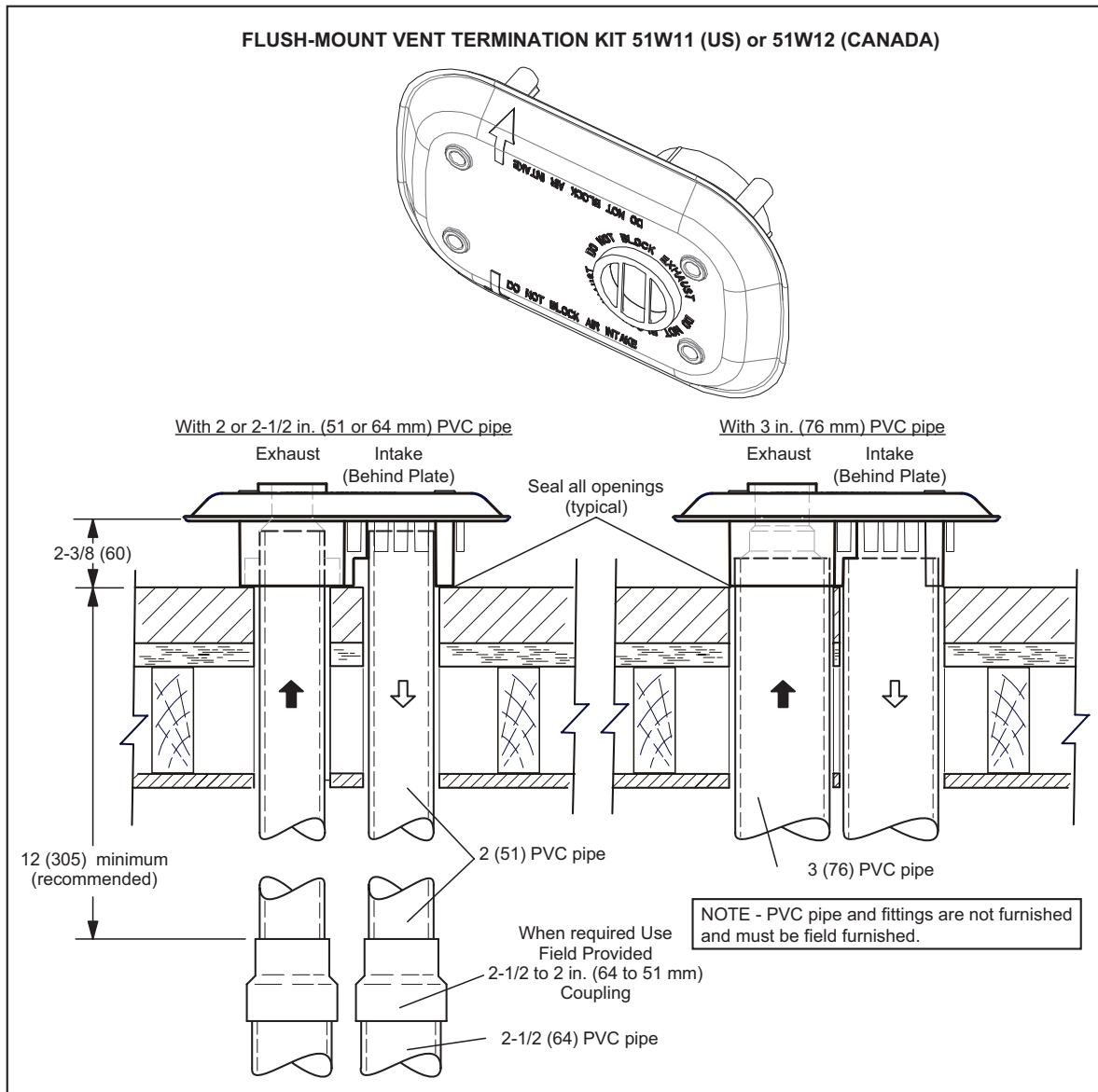

DIMENSIONS - OPTIONAL ACCESSORIES - VENTING

**CONCENTRIC WALL
TERMINATION APPLICATIONS**

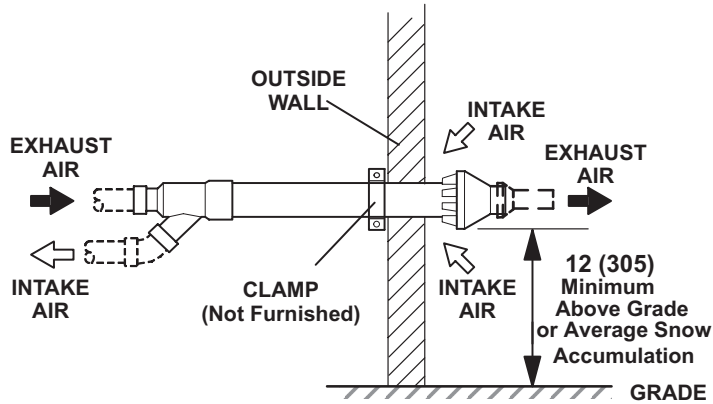

**CONCENTRIC ROOF
TERMINATION APPLICATIONS**

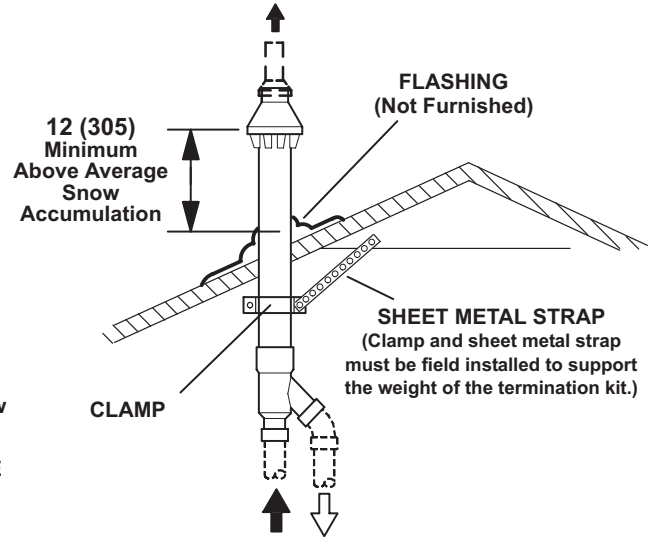

71M80 / 69M29 / 44W92 – 2 inch kits
60L46 / 44W93 – 3 inch kits
See Installation Instructions for additional information.

Note - Field provided reducer may be required to adapt different vent pipe sizes to termination.

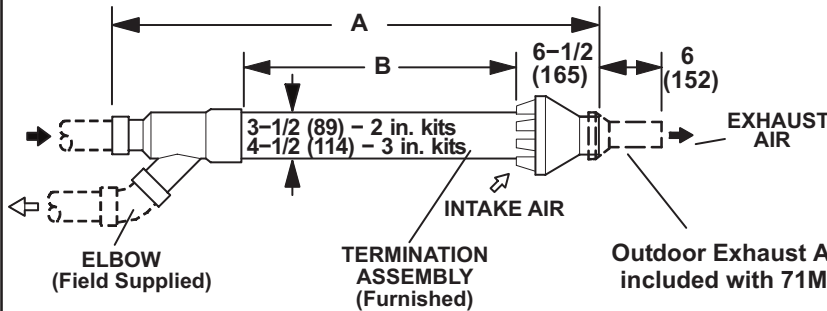

Cat. No.	A		B	
	in.	mm	in.	mm
71M80 69M29	33-3/8	848	16-3/4	425
44W92 (Canada)	29	737	15-1/2	394
60L46	38-7/8	987	21-3/16	538
44W93 (Canada)	36-1/8	918	19-1/2	495

NOTE - Typical illustration for dimensions only. Design may vary depending on kit ordered.

**WALL TERMINATION KITS (CLOSE-COUPLE)
EXTENDED VENT FOR GRADE CLEARANCE
2 inch (51 mm) 22G44 (US)
3 inch (76 mm) 44J40 (US)**

See Installation Instructions for additional information.

Note - Field provided reducer may be required to adapt different vent pipe sizes to termination.

If Intake and Exhaust Pipe is less than 12 in. (305 mm) above snow accumulation or other obstructions, field fabricated piping must be installed.

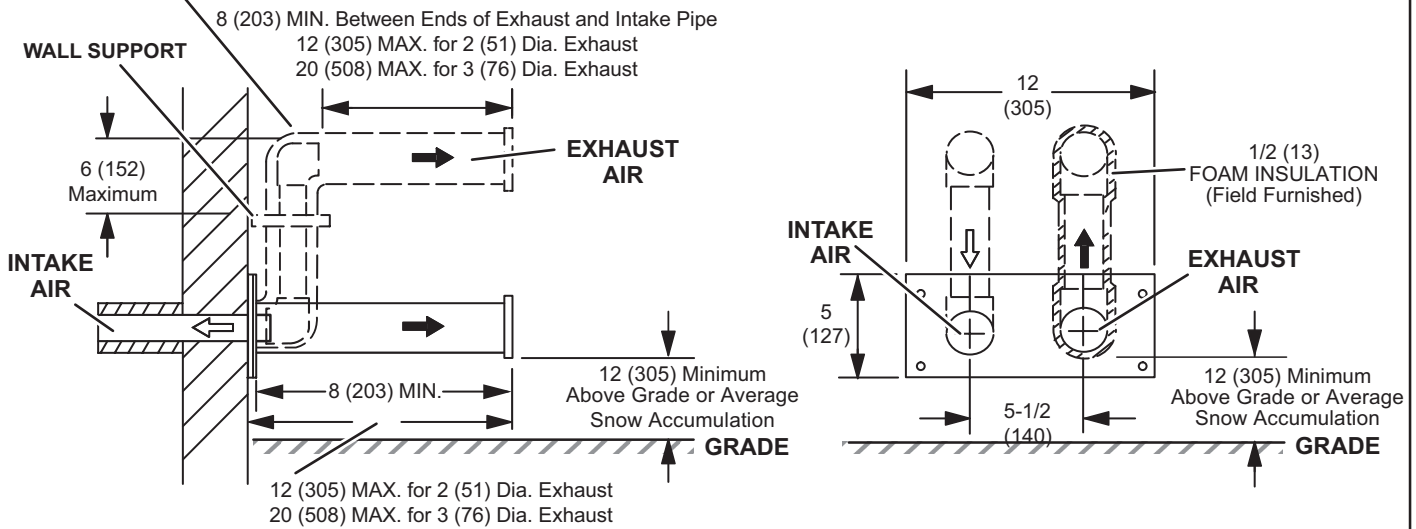

**WALL TERMINATION KITS (CLOSE-COUPLE)
EXTENDED VENT FOR GRADE CLEARANCE
2 inch (51 mm) 30G28 (WTK Canada)
3 inch (76 mm) 81J20 (WTK Canada)**

See Installation Instructions for additional information.

Note - Field provided reducer may be required to adapt different vent pipe sizes to termination.

If Intake and Exhaust Pipe is less than 12 in. (305 mm) above snow accumulation or other obstructions, field fabricated piping must be installed.

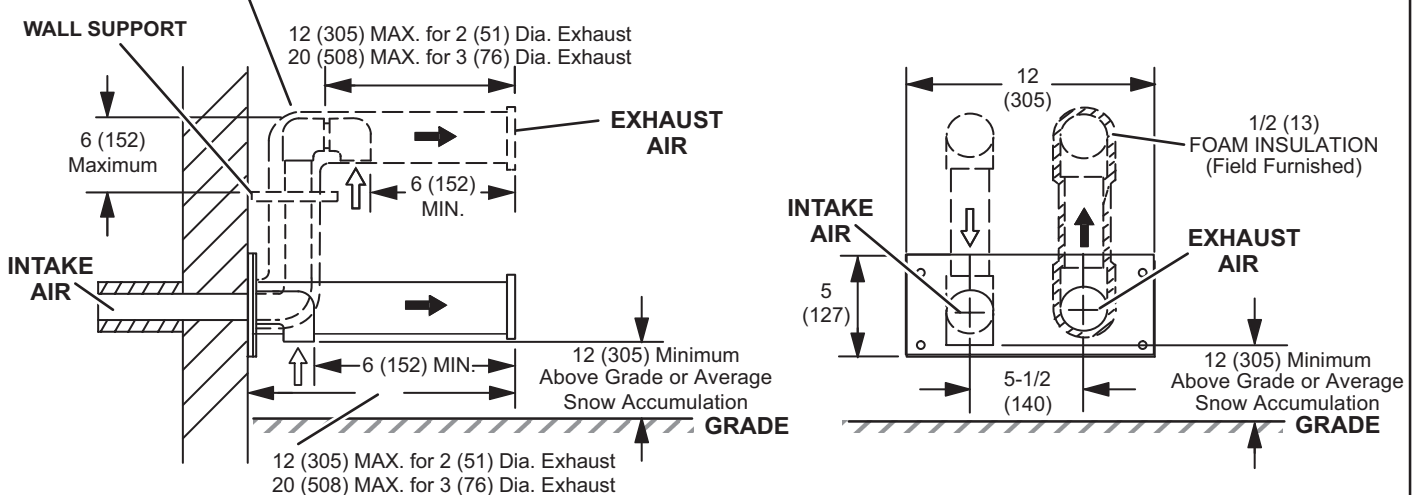

BLOWER DATA

SLP99UH070XV36B BLOWER PERFORMANCE (less filter)

BOTTOM RETURN AIR

HEATING BLOWER PERFORMANCE - 0 through 0.8 in. w.g. External Static Pressure Range

Heating Adjust CFM Selections	Heating Input Range and Blower Volume - CFM							
	35%	40%	50%	60%	70%	80%	90%	100%
Increase (+15%) Heat CFM	489	538	636	735	833	931	1030	1128
Increase (+7.5%) Heat CFM	450	496	588	680	772	864	956	1048
Default Heat CFM	410	453	539	624	710	796	881	967
Decrease (-7.5%) Heat CFM	380	419	498	578	657	736	815	895
Decrease (-15%) Heat CFM	349	385	458	531	604	676	749	822

COOLING BLOWER PERFORMANCE - 0 through 1.0 in. w.g. External Static Pressure Range

Cooling Adjust CFM Selections	Blower Speed Selections							
	First Stage Cool Speed - cfm				Second Stage Cool Speed - cfm			
	Low	Medium-Low	Medium High	High (Default)	Low	Medium-Low	Medium High	High (Default)
Increase (+10%) Cool CFM	610	745	865	995	900	1070	1235	1405
Default Cool CFM	560	675	785	890	810	970	1125	1265
Decrease (-10%) Cool CFM	510	615	700	795	720	875	1015	1145

The effect of static pressure is included in air volumes shown.

The following control configurations are available. See Installation Instructions for details and DIP switch settings.

Heat Modes Available (Heating Blower Performance Table):

Single stage thermostat:

- 35%, 70%, 100% input (three-stage) with time delays in-between.

Two-stage thermostat:

- Variable Rate Capacity Mode - furnace automatically adjusts firing rate based on first- and second-stage cycle times.

- W1 demand at 70% input, W2 demand at 100% input. No delay between stages.

Cool Mode Available (Cooling Blower Performance table):

First stage COOL (two-stage air conditioning units only) is approximately 70% of the same second stage COOL speed position.

Continuous Fan speeds are approximately 28% and 38% (DIP switch selectable) of the same second-stage COOL speed position. minimum 250 cfm.

Lennox® Smart Zoning System Applications - Minimum blower speed is 250 cfm.

SLP99UH070XV36B BLOWER MOTOR WATTS - COOLING

Blower Speed Options	Motor Watts @ Various External Static Pressures - in. wg.																			
	First Stage										Second Stage									
	0.1	0.2	0.3	0.4	0.5	0.6	0.7	0.8	0.9	1.0	0.1	0.2	0.3	0.4	0.5	0.6	0.7	0.8	0.9	1.0
Increase (+10%) Cool CFM																				
Low	44	58	72	85	97	109	122	135	149	161	91	112	131	150	169	186	204	221	236	258
Medium-Low	63	79	96	112	128	144	160	173	187	206	149	170	191	210	229	248	266	284	301	323
Medium-High	83	104	123	143	161	179	194	211	227	248	219	241	264	284	305	325	345	365	386	408
High	120	141	168	199	234	272	312	354	399	447	309	332	356	381	401	420	441	462	482	506
Default Cool CFM																				
Low	39	52	65	77	88	100	112	125	136	148	72	89	108	126	144	162	178	193	208	228
Medium-Low	53	68	82	97	112	125	138	152	167	181	114	135	154	173	192	210	228	246	262	283
Medium-High	67	85	103	120	137	154	170	185	200	219	173	194	215	234	253	270	291	311	327	348
High	91	111	129	149	168	187	204	219	234	256	239	260	281	300	323	344	365	386	403	426
Decrease (-10%) Cool CFM																				
Low	34	47	58	69	80	92	103	114	124	136	58	74	90	106	122	137	152	166	180	197
Medium-Low	45	58	72	85	98	110	123	136	149	162	83	104	124	143	161	179	196	211	227	249
Medium-High	55	70	87	102	117	131	145	159	173	190	127	149	169	190	209	227	245	263	280	301
High	70	87	106	124	141	159	175	189	204	224	182	203	224	244	264	284	303	321	341	362

BLOWER DATA

SLP99UH070XV36B BLOWER PERFORMANCE (less filter)

SINGLE SIDE RETURN AIR

HEATING BLOWER PERFORMANCE - 0 through 0.8 in. w.g. External Static Pressure Range

Heating Adjust CFM Selections	Heating Input Range and Blower Volume - CFM							
	35%	40%	50%	60%	70%	80%	90%	100%
Increase (+15%) Heat CFM	484	531	625	718	812	906	999	1093
Increase (+7.5%) Heat CFM	446	490	579	667	756	845	933	1022
Default Heat CFM	407	449	533	616	700	784	867	951
Decrease (-7.5%) Heat CFM	377	413	487	561	635	709	783	857
Decrease (-15%) Heat CFM	346	378	442	506	571	635	699	763

COOLING BLOWER PERFORMANCE - 0 through 1.0 in. w.g. External Static Pressure Range

Cooling Adjust CFM Selections	Blower Speed Selections							
	First Stage Cool Speed - cfm				Second Stage Cool Speed - cfm			
	Low	Medium-Low	Medium High	High (Default)	Low	Medium-Low	Medium High	High (Default)
Increase (+10%) Cool CFM	590	705	805	955	840	1050	1205	1355
Default Cool CFM	540	640	725	820	750	945	1130	1230
Decrease (-10%) Cool CFM	500	580	665	720	685	805	990	1110

The effect of static pressure is included in air volumes shown.

The following control configurations are available. See Installation Instructions for details and DIP switch settings.

Heat Modes Available (Heating Blower Performance Table):

Single stage thermostat:

- 35%, 70%, 100% input (three-stage) with time delays in-between.

Two-stage thermostat:

- Variable Rate Capacity Mode - furnace automatically adjusts firing rate based on first- and second-stage cycle times.
- W1 demand at 70% input, W2 demand at 100% input. No delay between stages.

Cool Mode Available (Cooling Blower Performance table):

First stage COOL (two-stage air conditioning units only) is approximately 70% of the same second stage COOL speed position.

Continuous Fan speeds are approximately 28% and 38% (DIP switch selectable) of the same second-stage COOL speed position. minimum 250 cfm.

Lennox® Smart Zoning System Applications - Minimum blower speed is 250 cfm.

SLP99UH070XV36B BLOWER MOTOR WATTS - COOLING

Blower Speed Options	Motor Watts @ Various External Static Pressures - in. wg.																			
	First Stage										Second Stage									
	0	0.1	0.2	0.3	0.4	0.5	0.6	0.7	0.8	0	0.1	0.2	0.3	0.4	0.5	0.6	0.7	0.8	0.9	1.0
Increase (+10%) Cool CFM																				
Low	17	29	48	61	73	94	100	123	130	63	84	104	117	142	160	174	208	215	245	255
Medium-Low	30	50	66	79	107	128	137	159	178	121	137	165	195	213	239	257	283	303	329	342
Medium-High	51	70	92	106	127	150	170	184	207	195	214	243	268	290	324	348	370	387	409	434
High	88	109	134	150	184	201	221	243	265	290	309	344	372	399	421	445	474	495	520	532
Default Cool CFM																				
Low	12	25	38	52	66	83	96	105	117	43	65	75	98	120	139	152	170	192	212	228
Medium-Low	22	41	55	70	86	103	123	141	154	88	106	130	150	173	197	220	239	259	276	297
Medium-High	36	55	75	90	107	129	152	167	184	142	161	187	211	239	263	287	307	332	352	369
High	57	76	99	116	135	153	176	197	213	220	236	267	294	323	342	364	382	411	436	455
Decrease (-10%) Cool CFM																				
Low	8	22	32	50	60	77	86	100	116	31	48	63	83	102	122	137	150	166	188	203
Medium-Low	19	32	47	63	77	93	103	120	133	53	75	91	111	129	152	169	188	210	227	251
Medium-High	25	42	58	74	90	109	131	143	154	101	120	141	170	190	215	233	256	274	298	317
High	37	56	76	95	115	135	153	173	192	157	177	201	224	254	277	303	321	346	362	385

BLOWER DATA

SLP99UH070XV36B BLOWER PERFORMANCE (less filter)

SINGLE SIDE RETURN AIR WITH OPTIONAL RETURN AIR BASE

HEATING BLOWER PERFORMANCE - 0 through 0.8 in. w.g. External Static Pressure Range

Heating Adjust CFM Selections	Heating Input Range and Blower Volume - CFM							
	35%	40%	50%	60%	70%	80%	90%	100%
Increase (+15%) Heat CFM	471	519	614	709	805	900	996	1091
Increase (+7.5%) Heat CFM	435	480	570	660	751	841	931	1021
Default Heat CFM	399	441	526	611	696	781	866	951
Decrease (-7.5%) Heat CFM	369	408	486	564	643	721	799	877
Decrease (-15%) Heat CFM	339	375	446	517	589	660	732	803

COOLING BLOWER PERFORMANCE - 0 through 1.0 in. w.g. External Static Pressure Range

Cooling Adjust CFM Selections	Blower Speed Selections							
	First Stage Cool Speed - cfm				Second Stage Cool Speed - cfm			
	Low	Medium-Low	Medium High	High (Default)	Low	Medium-Low	Medium High	High (Default)
Increase (+10%) Cool CFM	595	715	815	950	855	1045	1205	1350
Default Cool CFM	520	655	755	840	790	945	1090	1255
Decrease (-10%) Cool CFM	490	595	670	745	720	845	985	1130

The effect of static pressure is included in air volumes shown.

The following control configurations are available. See Installation Instructions for details and DIP switch settings.

Heat Modes Available (Heating Blower Performance Table):

Single stage thermostat:

- 35%, 70%, 100% input (three-stage) with time delays in-between.

Two-stage thermostat:

- Variable Rate Capacity Mode - furnace automatically adjusts firing rate based on first- and second-stage cycle times.

- W1 demand at 70% input, W2 demand at 100% input. No delay between stages.

Cool Mode Available (Cooling Blower Performance table):

First stage COOL (two-stage air conditioning units only) is approximately 70% of the same second stage COOL speed position.

Continuous Fan speeds are approximately 28% and 38% (DIP switch selectable) of the same second-stage COOL speed position. minimum 250 cfm.

Lennox® Smart Zoning System Applications - Minimum blower speed is 250 cfm.

SLP99UH070XV36B BLOWER MOTOR WATTS - COOLING

Blower Speed Options	Motor Watts @ Various External Static Pressures - in. wg.																			
	First Stage										Second Stage									
	0	0.1	0.2	0.3	0.4	0.5	0.6	0.7	0.8	0	0.1	0.2	0.3	0.4	0.5	0.6	0.7	0.8	0.9	1.0
Increase (+10%) Cool CFM																				
Low	18	32	46	61	76	89	104	115	133	64	83	95	120	141	159	175	203	208	234	246
Medium-Low	34	52	69	86	104	126	141	160	174	109	131	150	179	204	219	239	268	283	313	335
Medium-High	63	82	98	115	138	153	173	187	209	177	197	227	246	273	311	328	354	383	402	408
High	88	107	131	148	175	192	217	235	253	255	281	312	346	382	402	430	465	489	506	533
Default Cool CFM																				
Low	12	25	37	55	66	82	94	105	121	43	61	76	99	121	133	162	169	189	211	224
Medium-Low	25	40	55	74	89	109	120	136	150	76	96	112	138	162	186	207	232	243	262	281
Medium-High	41	61	75	98	115	135	151	173	189	129	150	177	198	227	247	272	301	324	332	369
High	63	86	99	122	139	159	180	204	216	209	227	254	282	298	324	341	364	395	413	428
Decrease (-10%) Cool CFM																				
Low	9	20	35	48	59	75	86	94	110	29	43	63	84	99	113	131	144	164	185	197
Medium-Low	16	32	45	62	75	90	103	119	138	56	71	101	112	131	158	168	184	207	235	245
Medium-High	28	43	63	77	98	115	132	145	162	88	107	129	154	183	204	214	245	263	281	308
High	46	61	86	100	121	136	153	172	193	142	163	187	216	236	261	279	301	325	356	375

BLOWER DATA

SLP99UH090XV36C BLOWER PERFORMANCE (less filter)

BOTTOM RETURN AIR

HEATING BLOWER PERFORMANCE - 0 through 0.8 in. w.g. External Static Pressure Range

Heating Adjust CFM Selections	Heating Input Range and Blower Volume - CFM							
	35%	40%	50%	60%	70%	80%	90%	100%
Increase (+15%) Heat CFM	687	734	827	921	1014	1108	1201	1295
Increase (+7.5%) Heat CFM	654	697	782	867	953	1038	1123	1209
Default Heat CFM	621	660	737	814	891	968	1045	1122
Decrease (-7.5%) Heat CFM	581	616	687	757	828	899	970	1041
Decrease (-15%) Heat CFM	540	572	637	701	766	830	895	959

COOLING BLOWER PERFORMANCE - 0 through 1.0 in. w.g. External Static Pressure Range

Cooling Adjust CFM Selections	Blower Speed Selections							
	First Stage Cool Speed - cfm				Second Stage Cool Speed - cfm			
	Low	Medium-Low	Medium High	High (Default)	Low	Medium-Low	Medium High	High (Default)
Increase (+10%) Cool CFM	640	750	835	950	875	1040	1185	1365
Default Cool CFM	600	695	775	855	800	940	1090	1220
Decrease (-10%) Cool CFM	540	640	710	785	715	850	980	1105

The effect of static pressure is included in air volumes shown.

The following control configurations are available. See Installation Instructions for details and DIP switch settings.

Heat Modes Available (Heating Blower Performance Table):

Single stage thermostat:

- 35%, 70%, 100% input (three-stage) with time delays in-between.

Two-stage thermostat:

- Variable Rate Capacity Mode - furnace automatically adjusts firing rate based on first- and second-stage cycle times.
- W1 demand at 70% input, W2 demand at 100% input. No delay between stages.

Cool Mode Available (Cooling Blower Performance table):

First stage COOL (two-stage air conditioning units only) is approximately 70% of the same second stage COOL speed position.

Continuous Fan speeds are approximately 28% and 38% (DIP switch selectable) of the same second-stage COOL speed position. minimum 250 cfm.

Lennox® Smart Zoning System Applications - Minimum blower speed is 250 cfm.

SLP99UH090XV36C BLOWER MOTOR WATTS - COOLING

Blower Speed Options	Motor Watts @ Various External Static Pressures - in. wg.																			
	First Stage										Second Stage									
	0.1	0.2	0.3	0.4	0.5	0.6	0.7	0.8	0.9	1.0	0.1	0.2	0.3	0.4	0.5	0.6	0.7	0.8	0.9	1.0
Increase (+10%) Cool CFM																				
Low	45	60	74	92	105	119	134	149	165	180	74	95	116	136	158	181	201	222	240	263
Medium-Low	57	74	91	110	129	146	163	181	199	217	109	135	160	183	206	229	249	273	293	319
Medium-High	70	89	109	129	150	172	191	210	229	251	164	190	215	239	262	286	309	334	360	383
High	91	114	101	122	145	162	181	198	215	227	238	267	296	323	351	376	402	427	451	481
Default Cool CFM																				
Low	40	54	70	83	96	109	123	137	152	165	63	82	101	122	145	162	181	198	215	238
Medium-Low	50	66	82	99	115	131	147	164	182	197	86	108	133	155	176	199	222	243	262	287
Medium-High	60	77	96	115	135	153	171	189	207	226	124	151	177	203	225	247	269	291	316	341
High	72	93	113	134	155	177	197	216	235	257	178	204	231	255	280	304	326	351	376	401
Decrease (-10%) Cool CFM																				
Low	34	49	63	76	87	100	113	124	133	149	56	71	88	107	126	141	159	176	193	210
Medium-Low	44	60	76	92	105	119	135	151	166	181	71	91	111	131	152	173	194	213	231	253
Medium-High	52	68	85	102	119	135	152	169	187	203	96	121	143	166	188	209	233	255	275	299
High	61	80	98	117	137	156	174	192	211	230	133	159	184	207	232	253	276	299	322	346

BLOWER DATA

SLP99UH090XV36C BLOWER PERFORMANCE (less filter)

SINGLE SIDE RETURN AIR

HEATING BLOWER PERFORMANCE - 0 through 0.8 in. w.g. External Static Pressure Range

Heating Adjust CFM Selections	Heating Input Range and Blower Volume - CFM							
	35%	40%	50%	60%	70%	80%	90%	100%
Increase (+15%) Heat CFM	657	702	792	881	971	1061	1150	1240
Increase (+7.5%) Heat CFM	631	673	757	841	926	1010	1094	1178
Default Heat CFM	605	644	723	802	880	959	1037	1116
Decrease (-7.5%) Heat CFM	574	608	676	745	814	882	951	1020
Decrease (-15%) Heat CFM	542	571	630	689	747	806	864	923

COOLING BLOWER PERFORMANCE - 0 through 1.0 in. w.g. External Static Pressure Range

Cooling Adjust CFM Selections	Blower Speed Selections							
	First Stage Cool Speed - cfm				Second Stage Cool Speed - cfm			
	Low	Medium-Low	Medium High	High (Default)	Low	Medium-Low	Medium High	High (Default)
Increase (+10%) Cool CFM	610	705	795	920	840	1015	1165	1300
Default Cool CFM	560	640	715	810	770	910	1050	1190
Decrease (-10%) Cool CFM	525	605	665	725	695	795	945	1110

The effect of static pressure is included in air volumes shown.

The following control configurations are available. See Installation Instructions for details and DIP switch settings.

Heat Modes Available (Heating Blower Performance Table):

Single stage thermostat:

- 35%, 70%, 100% input (three-stage) with time delays in-between.

Two-stage thermostat:

- Variable Rate Capacity Mode - furnace automatically adjusts firing rate based on first- and second-stage cycle times.

- W1 demand at 70% input, W2 demand at 100% input. No delay between stages.

Cool Mode Available (Cooling Blower Performance table):

First stage COOL (two-stage air conditioning units only) is approximately 70% of the same second stage COOL speed position.

Continuous Fan speeds are approximately 28% and 38% (DIP switch selectable) of the same second-stage COOL speed position. minimum 250 cfm.

Lennox® Smart Zoning System Applications - Minimum blower speed is 250 cfm.

SLP99UH090XV36C BLOWER MOTOR WATTS - COOLING

Blower Speed Options	Motor Watts @ Various External Static Pressures - in. wg.																			
	First Stage										Second Stage									
	0	0.1	0.2	0.3	0.4	0.5	0.6	0.7	0.8	0	0.1	0.2	0.3	0.4	0.5	0.6	0.7	0.8	0.9	1.0
Increase (+10%) Cool CFM																				
Low	13	30	46	62	75	93	110	129	143	42	60	83	101	122	144	163	181	206	219	241
Medium-Low	25	45	62	80	96	115	134	151	173	78	104	122	144	170	195	215	239	265	283	308
Medium-High	36	55	79	95	117	139	156	178	199	133	154	175	213	236	269	282	309	336	357	381
High	62	83	105	128	148	163	193	210	234	210	229	259	291	317	344	366	391	415	441	466
Default Cool CFM																				
Low	9	28	38	55	71	83	100	116	135	28	48	65	86	104	124	142	164	182	199	219
Medium-Low	20	38	52	69	83	102	120	135	152	59	81	100	125	142	162	182	204	229	248	269
Medium-High	26	46	63	83	101	117	141	157	178	95	118	142	165	192	213	244	264	288	314	329
High	39	59	81	98	121	143	161	180	202	149	171	199	229	257	285	306	330	359	389	403
Decrease (-10%) Cool CFM																				
Low	8	23	35	52	66	80	95	108	121	21	41	56	71	91	110	126	144	164	179	197
Medium-Low	12	29	44	59	75	92	111	126	140	35	56	73	95	115	137	155	176	198	216	235
Medium-High	20	37	56	71	86	104	122	143	155	70	89	114	135	157	175	199	225	242	266	282
High	27	47	67	82	102	124	142	160	181	104	125	150	178	207	232	251	273	297	321	350

BLOWER DATA

SLP99UH090XV36C BLOWER PERFORMANCE (less filter)

SINGLE SIDE RETURN AIR WITH OPTIONAL RETURN AIR BASE

HEATING BLOWER PERFORMANCE - 0 through 0.8 in. w.g. External Static Pressure Range

Heating Adjust CFM Selections	Heating Input Range and Blower Volume - CFM							
	35%	40%	50%	60%	70%	80%	90%	100%
Increase (+15%) Heat CFM	677	721	810	899	988	1076	1165	1254
Increase (+7.5%) Heat CFM	639	679	760	842	923	1004	1085	1167
Default Heat CFM	600	637	711	784	858	932	1005	1079
Decrease (-7.5%) Heat CFM	573	606	673	740	806	873	939	1006
Decrease (-15%) Heat CFM	546	576	635	695	754	814	873	933

COOLING BLOWER PERFORMANCE - 0 through 1.0 in. w.g. External Static Pressure Range

Cooling Adjust CFM Selections	Blower Speed Selections							
	First Stage Cool Speed - cfm				Second Stage Cool Speed - cfm			
	Low	Medium-Low	Medium High	High (Default)	Low	Medium-Low	Medium High	High (Default)
Increase (+10%) Cool CFM	605	715	810	930	850	995	1165	1305
Default Cool CFM	570	660	735	820	775	905	1050	1205
Decrease (-10%) Cool CFM	530	600	670	725	710	800	945	1070

The effect of static pressure is included in air volumes shown.

The following control configurations are available. See Installation Instructions for details and DIP switch settings.

Heat Modes Available (Heating Blower Performance Table):

Single stage thermostat:

- 35%, 70%, 100% input (three-stage) with time delays in-between.

Two-stage thermostat:

- Variable Rate Capacity Mode - furnace automatically adjusts firing rate based on first- and second-stage cycle times.
- W1 demand at 70% input, W2 demand at 100% input. No delay between stages.

Cool Mode Available (Cooling Blower Performance table):

First stage COOL (two-stage air conditioning units only) is approximately 70% of the same second stage COOL speed position.

Continuous Fan speeds are approximately 28% and 38% (DIP switch selectable) of the same second-stage COOL speed position. minimum 250 cfm.

Lennox® Smart Zoning System Applications - Minimum blower speed is 250 cfm.

SLP99UH090XV36C BLOWER MOTOR WATTS - COOLING

Blower Speed Options	Motor Watts @ Various External Static Pressures - in. wg.																			
	First Stage										Second Stage									
	0	0.1	0.2	0.3	0.4	0.5	0.6	0.7	0.8	0	0.1	0.2	0.3	0.4	0.5	0.6	0.7	0.8	0.9	1.0
Increase (+10%) Cool CFM																				
Low	12	29	43	59	75	92	111	123	139	41	62	86	102	123	145	165	185	205	229	253
Medium-Low	24	42	61	76	97	112	132	150	169	79	108	126	148	174	190	218	248	273	294	316
Medium-High	38	56	81	99	115	138	157	176	199	131	152	184	208	237	264	289	320	339	361	390
High	61	85	104	127	144	171	192	212	239	205	226	258	283	312	344	365	393	410	437	466
Default Cool CFM																				
Low	9	26	37	54	67	83	97	112	130	30	50	72	87	108	127	149	167	184	209	226
Medium-Low	19	37	53	67	83	101	119	135	153	62	86	101	129	144	165	189	215	232	251	275
Medium-High	27	48	65	82	101	119	139	161	177	91	114	140	163	195	220	239	265	289	315	339
High	42	62	85	99	121	143	162	183	203	149	167	201	228	258	289	316	333	355	389	403
Decrease (-10%) Cool CFM																				
Low	8	23	35	51	62	77	91	104	119	25	45	61	75	91	112	131	147	166	184	198
Medium-Low	13	29	46	60	78	93	110	125	140	40	61	81	103	119	143	162	179	204	220	245
Medium-High	22	41	57	70	88	109	127	144	159	70	92	120	133	165	178	203	231	246	274	301
High	29	50	69	83	106	123	143	164	183	101	124	151	180	203	227	257	276	306	326	358

BLOWER DATA

SLP99UH090XV48C BLOWER PERFORMANCE (less filter)

BOTTOM RETURN AIR

HEATING BLOWER PERFORMANCE - 0 through 0.8 in. w.g. External Static Pressure Range

Heating Adjust CFM Selections	Heating Input Range and Blower Volume - CFM							
	35%	40%	50%	60%	70%	80%	90%	100%
Increase (+15%) Heat CFM	769	835	968	1101	1234	1367	1500	1633
Increase (+7.5%) Heat CFM	713	776	902	1028	1155	1281	1407	1534
Default Heat CFM	656	716	836	955	1075	1195	1314	1434
Decrease (-7.5%) Heat CFM	595	652	767	882	997	1112	1227	1342
Decrease (-15%) Heat CFM	534	589	699	809	919	1029	1139	1249

COOLING BLOWER PERFORMANCE - 0 through 1.0 in. w.g. External Static Pressure Range

Cooling Adjust CFM Selections	Blower Speed Selections							
	First Stage Cool Speed - cfm				Second Stage Cool Speed - cfm			
	Low	Medium-Low	Medium High	High (Default)	Low	Medium-Low	Medium High	High (Default)
Increase (+10%) Cool CFM	815	975	1095	1270	1125	1375	1565	1785
Default Cool CFM	745	885	1005	1145	1030	1235	1445	1615
Decrease (-10%) Cool CFM	675	810	910	1040	950	1115	1305	1480

The effect of static pressure is included in air volumes shown.

The following control configurations are available. See Installation Instructions for details and DIP switch settings.

Heat Modes Available (Heating Blower Performance Table):

Single stage thermostat:

- 35%, 70%, 100% input (three-stage) with time delays in-between.

Two-stage thermostat:

- Variable Rate Capacity Mode - furnace automatically adjusts firing rate based on first- and second-stage cycle times.

- W1 demand at 70% input, W2 demand at 100% input. No delay between stages.

Cool Mode Available (Cooling Blower Performance table):

First stage COOL (two-stage air conditioning units only) is approximately 70% of the same second stage COOL speed position.

Continuous Fan speeds are approximately 28% and 38% (DIP switch selectable) of the same second-stage COOL speed position. minimum 380 cfm.

Lennox® Smart Zoning System Applications - Minimum blower speed is 380 cfm.

SLP99UH090XV48C BLOWER MOTOR WATTS - COOLING

Blower Speed Options	Motor Watts @ Various External Static Pressures - in. wg.																			
	First Stage										Second Stage									
	0	0.1	0.2	0.3	0.4	0.5	0.6	0.7	0.8	0	0.1	0.2	0.3	0.4	0.5	0.6	0.7	0.8	0.9	1.0
Increase (+10%) Cool CFM																				
Low	36	62	82	104	126	149	172	196	222	82	120	146	173	198	228	258	290	324	358	391
Medium-Low	60	88	110	134	160	189	213	235	264	152	190	222	255	288	319	352	387	424	462	499
Medium-High	81	113	139	166	191	221	251	282	313	238	282	315	349	384	418	455	494	532	575	618
High	125	161	192	220	250	283	316	351	388	366	422	448	487	522	566	603	642	692	739	786
Default Cool CFM																				
Low	30	54	72	93	114	137	158	180	203	64	98	122	147	176	201	227	259	292	320	350
Medium-Low	46	73	93	116	139	164	190	218	238	107	145	174	203	233	263	296	330	363	400	435
Medium-High	64	94	116	142	170	199	220	250	281	179	219	252	285	319	353	388	426	462	500	539
High	93	127	155	179	208	238	269	302	336	265	309	344	378	413	450	488	527	564	606	652
Decrease (-10%) Cool CFM																				
Low	29	54	64	82	102	122	141	161	182	52	80	102	124	149	176	205	227	250	277	306
Medium-Low	34	61	81	102	123	147	171	196	223	78	115	140	169	192	223	255	287	317	351	384
Medium-High	50	78	98	121	145	171	198	223	244	127	166	196	226	255	287	321	355	391	428	463
High	70	100	124	150	181	202	232	262	292	194	234	268	302	337	371	406	442	480	520	560

BLOWER DATA

SLP99UH090XV48C BLOWER PERFORMANCE (less filter)

SINGLE SIDE RETURN AIR

HEATING BLOWER PERFORMANCE - 0 through 0.8 in. w.g. External Static Pressure Range

Heating Adjust CFM Selections	Heating Input Range and Blower Volume - CFM							
	35%	40%	50%	60%	70%	80%	90%	100%
Increase (+15%) Heat CFM	747	812	943	1073	1204	1334	1465	1595
Increase (+7.5%) Heat CFM	698	759	882	1005	1127	1250	1372	1495
Default Heat CFM	649	706	821	936	1051	1165	1280	1395
Decrease (-7.5%) Heat CFM	589	644	755	867	978	1089	1200	1312
Decrease (-15%) Heat CFM	528	582	690	797	905	1013	1120	1228

COOLING BLOWER PERFORMANCE - 0 through 1.0 in. w.g. External Static Pressure Range

Cooling Adjust CFM Selections	Blower Speed Selections							
	First Stage Cool Speed - cfm				Second Stage Cool Speed - cfm			
	Low	Medium-Low	Medium High	High (Default)	Low	Medium-Low	Medium High	High (Default)
Increase (+10%) Cool CFM	820	1005	1135	1290	1140	1340	1525	1725
Default Cool CFM	755	880	1025	1150	1040	1235	1395	1565
Decrease (-10%) Cool CFM	680	815	925	1065	910	1120	1275	1400

The effect of static pressure is included in air volumes shown.

The following control configurations are available. See Installation Instructions for details and DIP switch settings.

Heat Modes Available (Heating Blower Performance Table):

Single stage thermostat:

- 35%, 70%, 100% input (three-stage) with time delays in-between.

Two-stage thermostat:

- Variable Rate Capacity Mode - furnace automatically adjusts firing rate based on first- and second-stage cycle times.
- W1 demand at 70% input, W2 demand at 100% input. No delay between stages.

Cool Mode Available (Cooling Blower Performance table):

First stage COOL (two-stage air conditioning units only) is approximately 70% of the same second stage COOL speed position.

Continuous Fan speeds are approximately 28% and 38% (DIP switch selectable) of the same second-stage COOL speed position. minimum 3808 cfm.

Lennox® Smart Zoning System Applications - Minimum blower speed is 380 cfm.

SLP99UH090XV48C BLOWER MOTOR WATTS - COOLING

Blower Speed Options	Motor Watts @ Various External Static Pressures - in. wg.																			
	First Stage										Second Stage									
	0	0.1	0.2	0.3	0.4	0.5	0.6	0.7	0.8	0	0.1	0.2	0.3	0.4	0.5	0.6	0.7	0.8	0.9	1.0
Increase (+10%) Cool CFM																				
Low	43	65	85	96	119	134	156	179	199	102	131	155	189	216	249	282	304	331	359	387
Medium-Low	66	95	113	140	164	189	212	242	268	173	196	242	271	306	337	362	405	430	460	493
Medium-High	95	126	151	180	210	242	277	302	320	243	277	316	371	412	457	492	534	566	605	651
High	143	166	203	243	282	309	333	368	389	368	410	453	511	562	604	651	690	730	771	809
Default Cool CFM																				
Low	36	48	73	86	108	120	140	152	168	75	101	125	156	178	215	244	259	288	320	339
Medium-Low	52	75	95	110	130	161	176	201	216	129	154	190	218	257	295	322	346	377	404	434
Medium-High	70	94	125	146	172	198	230	252	275	190	222	270	299	325	368	398	439	470	508	549
High	100	131	162	197	228	260	298	328	347	275	310	359	400	445	469	525	562	597	642	682
Decrease (-10%) Cool CFM																				
Low	32	45	58	80	97	110	121	133	154	62	87	109	129	152	173	199	221	250	266	295
Medium-Low	45	63	82	99	119	137	150	171	193	95	124	150	180	207	240	269	297	325	356	375
Medium-High	55	82	101	119	145	167	192	213	239	148	177	205	244	286	309	346	370	402	431	467
High	76	101	137	160	188	218	245	271	302	198	239	274	308	349	384	426	471	500	542	576

BLOWER DATA

SLP99UH090XV48C BLOWER PERFORMANCE (less filter)

SINGLE SIDE RETURN AIR WITH OPTIONAL RETURN AIR BASE

HEATING BLOWER PERFORMANCE - 0 through 0.8 in. w.g. External Static Pressure Range

Heating Adjust CFM Selections	Heating Input Range and Blower Volume - CFM							
	35%	40%	50%	60%	70%	80%	90%	100%
Increase (+15%) Heat CFM	764	828	956	1084	1213	1341	1469	1597
Increase (+7.5%) Heat CFM	705	766	888	1010	1132	1255	1377	1499
Default Heat CFM	645	703	819	936	1052	1168	1285	1401
Decrease (-7.5%) Heat CFM	594	650	762	874	986	1099	1211	1323
Decrease (-15%) Heat CFM	542	596	704	812	921	1029	1137	1245

COOLING BLOWER PERFORMANCE - 0 through 1.0 in. w.g. External Static Pressure Range

Cooling Adjust CFM Selections	Blower Speed Selections							
	First Stage Cool Speed - cfm				Second Stage Cool Speed - cfm			
	Low	Medium-Low	Medium High	High (Default)	Low	Medium-Low	Medium High	High (Default)
Increase (+10%) Cool CFM	840	955	1120	1280	1160	1360	1530	1740
Default Cool CFM	775	910	1010	1170	1060	1240	1400	1590
Decrease (-10%) Cool CFM	695	815	930	1045	925	1130	1295	1440

The effect of static pressure is included in air volumes shown.

The following control configurations are available. See Installation Instructions for details and DIP switch settings.

Heat Modes Available (Heating Blower Performance Table):

Single stage thermostat:

- 35%, 70%, 100% input (three-stage) with time delays in-between.

Two-stage thermostat:

- Variable Rate Capacity Mode - furnace automatically adjusts firing rate based on first- and second-stage cycle times.

- W1 demand at 70% input, W2 demand at 100% input. No delay between stages.

Cool Mode Available (Cooling Blower Performance table):

First stage COOL (two-stage air conditioning units only) is approximately 70% of the same second stage COOL speed position.

Continuous Fan speeds are approximately 28% and 38% (DIP switch selectable) of the same second-stage COOL speed position. minimum 380 cfm.

Lennox® Smart Zoning System Applications - Minimum blower speed is 380 cfm.

SLP99UH090XV48C BLOWER MOTOR WATTS - COOLING

Blower Speed Options	Motor Watts @ Various External Static Pressures - in. wg.																			
	First Stage										Second Stage									
	0	0.1	0.2	0.3	0.4	0.5	0.6	0.7	0.8	0	0.1	0.2	0.3	0.4	0.5	0.6	0.7	0.8	0.9	1.0
Increase (+10%) Cool CFM																				
Low	40	60	80	96	115	133	151	176	192	94	127	151	180	207	241	274	303	340	358	381
Medium-Low	58	87	108	132	158	188	212	240	264	166	195	233	269	300	328	356	394	426	455	496
Medium-High	91	126	145	169	205	228	255	288	320	234	273	314	354	403	431	484	514	571	599	632
High	134	163	195	231	264	297	320	359	381	337	378	426	470	518	557	604	654	684	722	768
Default Cool CFM																				
Low	36	47	70	88	103	120	139	146	167	75	100	130	149	183	212	238	260	293	315	337
Medium-Low	51	75	93	115	135	158	187	201	222	132	156	192	220	259	284	319	343	376	404	423
Medium-High	59	92	112	141	166	200	228	259	281	183	215	262	284	315	348	387	427	464	494	523
High	97	130	156	191	215	256	283	310	343	253	292	331	379	414	462	497	546	575	613	661
Decrease (-10%) Cool CFM																				
Low	26	41	55	73	88	104	120	134	149	56	84	104	123	149	174	199	224	248	268	290
Medium-Low	41	62	79	98	117	132	154	172	195	94	122	146	177	208	239	264	295	320	352	368
Medium-High	50	75	95	120	147	164	187	209	243	140	170	197	234	263	301	327	357	377	412	453
High	72	102	125	154	178	208	234	262	293	196	235	264	302	332	377	413	441	482	518	548

BLOWER DATA

SLP99UH090XV60C BLOWER PERFORMANCE (less filter)

BOTTOM RETURN AIR

HEATING BLOWER PERFORMANCE - 0 through 0.8 in. w.g. External Static Pressure Range

Heating Adjust CFM Selections	Heating Input Range and Blower Volume - CFM							
	35%	40%	50%	60%	70%	80%	90%	100%
Increase (+15%) Heat CFM	583	665	830	995	1159	1324	1488	1653
Increase (+7.5%) Heat CFM	540	618	774	930	1085	1241	1397	1553
Default Heat CFM	497	571	718	865	1012	1159	1306	1453
Decrease (-7.5%) Heat CFM	439	507	644	781	917	1054	1191	1328
Decrease (-15%) Heat CFM	380	443	570	697	823	950	1076	1203

COOLING BLOWER PERFORMANCE - 0 through 1.0 in. w.g. External Static Pressure Range

Cooling Adjust CFM Selections	Blower Speed Selections							
	First Stage Cool Speed - cfm				Second Stage Cool Speed - cfm			
	Low	Medium-Low	Medium High	High (Default)	Low	Medium-Low	Medium High	High (Default)
Increase (+10%) Cool CFM	1105	1280	1400	1590	1590	1820	2025	2270
Default Cool CFM	1015	1165	1285	1425	1425	1635	1855	2035
Decrease (-10%) Cool CFM	920	1055	1165	1295	1290	1470	1655	1855

The effect of static pressure is included in air volumes shown.

The following control configurations are available. See Installation Instructions for details and DIP switch settings.

Heat Modes Available (Heating Blower Performance Table):

Single stage thermostat:

- 35%, 70%, 100% input (three-stage) with time delays in-between.

Two-stage thermostat:

- Variable Rate Capacity Mode - furnace automatically adjusts firing rate based on first- and second-stage cycle times.
- W1 demand at 70% input, W2 demand at 100% input. No delay between stages.

Cool Mode Available (Cooling Blower Performance table):

First stage COOL (two-stage air conditioning units only) is approximately 70% of the same second stage COOL speed position.

Continuous Fan speeds are approximately 28% and 38% (DIP switch selectable) of the same second-stage COOL speed position. minimum 380 cfm.

Lennox® Smart Zoning System Applications - Minimum blower speed is 450 cfm.

SLP99UH090XV60C BLOWER MOTOR WATTS - COOLING

Blower Speed Options	Motor Watts @ Various External Static Pressures - in. wg.																			
	First Stage										Second Stage									
	0.1	0.2	0.3	0.4	0.5	0.6	0.7	0.8	0.9	1.0	0.1	0.2	0.3	0.4	0.5	0.6	0.7	0.8	0.9	1.0
Increase (+10%) Cool CFM																				
Low	124	145	167	192	219	246	273	300	329	351	278	313	350	386	421	455	491	528	568	601
Medium-Low	167	195	220	246	273	305	338	372	406	429	407	446	481	516	558	596	633	673	716	750
Medium-High	207	234	263	293	325	360	397	438	479	502	554	599	636	676	719	767	815	865	912	950
High	278	313	350	386	420	455	490	527	568	600	807	855	890	929	964	1040	1023	1013	997	985
Default Cool CFM																				
Low	102	123	143	168	194	217	242	268	294	316	213	243	273	304	337	373	410	450	491	517
Medium-Low	137	160	182	208	235	264	292	322	351	374	311	344	377	411	445	482	519	559	598	629
Medium-High	170	194	220	246	275	306	340	374	410	431	427	466	504	542	584	622	655	702	749	782
High	213	243	273	305	338	374	411	450	491	517	580	618	653	693	730	772	819	862	909	943
Decrease (-10%) Cool CFM																				
Low	83	101	123	146	168	190	213	237	261	281	174	198	223	250	279	310	345	379	415	437
Medium-Low	111	132	153	178	204	230	256	281	307	330	229	260	291	324	358	395	431	470	509	538
Medium-High	137	160	182	208	235	264	292	322	351	374	319	355	390	423	456	495	532	569	610	641
High	174	197	223	250	279	310	345	379	415	437	427	466	504	542	584	622	655	702	749	782

BLOWER DATA

SLP99UH090XV60C BLOWER PERFORMANCE (less filter)

SINGLE SIDE RETURN AIR – Air volumes in **bold** require Optional Return Air Base and field fabricated transition to accommodate 20 x 25 x 1 in. air filter in order to maintain proper air velocity.

HEATING BLOWER PERFORMANCE - 0 through 0.8 in. w.g. External Static Pressure Range

Heating Adjust CFM Selections	Heating Input Range and Blower Volume - CFM							
	35%	40%	50%	60%	70%	80%	90%	100%
Increase (+15%) Heat CFM	609	684	835	986	1136	1287	1437	1588
Increase (+7.5%) Heat CFM	551	623	769	914	1059	1205	1350	1496
Default Heat CFM	492	562	702	842	983	1123	1263	1403
Decrease (-7.5%) Heat CFM	436	502	633	765	896	1028	1159	1291
Decrease (-15%) Heat CFM	380	441	564	687	810	932	1055	1178

COOLING BLOWER PERFORMANCE - 0 through 1.0 in. w.g. External Static Pressure Range

Cooling Adjust CFM Selections	Blower Speed Selections							
	First Stage Cool Speed - cfm				Second Stage Cool Speed - cfm			
	Low	Medium-Low	Medium High	High (Default)	Low	Medium-Low	Medium High	High (Default)
Increase (+10%) Cool CFM	1040	1225	1380	1550	1555	1715	1920	2135
Default Cool CFM	960	1085	1225	1415	1430	1565	1790	1980
Decrease (-10%) Cool CFM	840	990	1085	1250	1280	1450	1580	1790

The effect of static pressure is included in air volumes shown.

The following control configurations are available. See Installation Instructions for details and DIP switch settings.

Heat Modes Available (Heating Blower Performance Table):

Single stage thermostat:

- 35%, 70%, 100% input (three-stage) with time delays in-between.

Two-stage thermostat:

- Variable Rate Capacity Mode - furnace automatically adjusts firing rate based on first- and second-stage cycle times.

- W1 demand at 70% input, W2 demand at 100% input. No delay between stages.

Cool Mode Available (Cooling Blower Performance table):

First stage COOL (two-stage air conditioning units only) is approximately 70% of the same second stage COOL speed position.

Continuous Fan speeds are approximately 28% and 38% (DIP switch selectable) of the same second-stage COOL speed position. minimum 380 cfm.

Lennox® Smart Zoning System Applications - Minimum blower speed is 450 cfm.

SLP99UH090XV60C BLOWER MOTOR WATTS - COOLING

Blower Speed Options	Motor Watts @ Various External Static Pressures - in. wg.																			
	First Stage										Second Stage									
	0	0.1	0.2	0.3	0.4	0.5	0.6	0.7	0.8	0	0.1	0.2	0.3	0.4	0.5	0.6	0.7	0.8	0.9	1.0
Increase (+10%) Cool CFM																				
Low	66	95	123	147	173	204	233	260	290	241	273	315	357	405	433	466	519	547	584	620
Medium-Low	108	139	173	210	248	283	315	342	376	332	374	428	489	518	568	631	665	719	762	813
Medium-High	159	192	233	272	314	359	386	421	457	518	557	601	675	713	772	819	873	913	949	987
High	241	273	315	357	405	433	466	519	547	713	750	822	866	946	986	1042	1085	1116	1144	1184
Default Cool CFM																				
Low	55	81	101	126	144	165	194	217	243	181	204	251	292	323	369	403	444	474	496	525
Medium-Low	75	109	134	159	194	226	255	282	316	270	304	361	389	433	473	506	547	602	642	665
Medium-High	108	144	180	211	248	293	320	357	391	374	410	467	512	583	618	670	723	778	797	839
High	181	204	251	292	323	369	403	444	474	542	579	642	684	743	809	843	883	942	991	1019
Decrease (-10%) Cool CFM																				
Low	36	56	71	102	119	141	161	179	198	113	142	181	221	255	300	325	352	395	424	456
Medium-Low	57	84	110	133	151	175	210	234	257	170	208	209	303	343	382	417	455	489	509	552
Medium-High	75	109	134	159	194	226	255	282	316	264	299	357	387	426	478	501	551	586	635	682
High	113	142	181	221	255	300	325	352	395	374	410	467	512	583	618	670	723	778	797	839

BLOWER DATA

SLP99UH110XV60C BLOWER PERFORMANCE (less filter)

BOTTOM RETURN AIR

HEATING BLOWER PERFORMANCE - 0 through 0.8 in. w.g. External Static Pressure Range

Heating Adjust CFM Selections	Heating Input Range and Blower Volume - CFM							
	35%	40%	50%	60%	70%	80%	90%	100%
Increase (+15%) Heat CFM	767	861	1049	1237	1424	1612	1800	1988
Increase (+7.5%) Heat CFM	738	825	1000	1174	1349	1524	1699	1874
Default Heat CFM	708	789	951	1112	1274	1436	1597	1759
Decrease (-7.5%) Heat CFM	655	731	883	1035	1187	1339	1491	1644
Decrease (-15%) Heat CFM	602	673	816	958	1101	1243	1386	1528

COOLING BLOWER PERFORMANCE - 0 through 1.0 in. w.g. External Static Pressure Range

Cooling Adjust CFM Selections	Blower Speed Selections							
	First Stage Cool Speed - cfm				Second Stage Cool Speed - cfm			
	Low	Medium-Low	Medium High	High (Default)	Low	Medium-Low	Medium High	High (Default)
Increase (+10%) Cool CFM	1050	1200	1305	1485	1490	1705	1915	2130
Default Cool CFM	960	1100	1205	1335	1340	1540	1750	1925
Decrease (-10%) Cool CFM	860	995	1100	1220	1220	1390	1570	1750

The effect of static pressure is included in air volumes shown.

The following control configurations are available. See Installation Instructions for details and DIP switch settings.

Heat Modes Available (Heating Blower Performance Table):

Single stage thermostat:

- 35%, 70%, 100% input (three-stage) with time delays in-between.

Two-stage thermostat:

- Variable Rate Capacity Mode - furnace automatically adjusts firing rate based on first- and second-stage cycle times.

- W1 demand at 70% input, W2 demand at 100% input. No delay between stages.

Cool Mode Available (Cooling Blower Performance table):

First stage COOL (two-stage air conditioning units only) is approximately 70% of the same second stage COOL speed position.

Continuous Fan speeds are approximately 28% and 38% (DIP switch selectable) of the same second-stage COOL speed position. minimum 380 cfm.

Lennox® Smart Zoning System Applications - Minimum blower speed is 450 cfm.

SLP99UH110XV60C BLOWER MOTOR WATTS - COOLING

Blower Speed Options	Motor Watts @ Various External Static Pressures - in. wg.																			
	First Stage										Second Stage									
	0.1	0.2	0.3	0.4	0.5	0.6	0.7	0.8	0.9	1.0	0.1	0.2	0.3	0.4	0.5	0.6	0.7	0.8	0.9	1.0
Increase (+10%) Cool CFM																				
Low	101	123	145	168	192	216	243	272	299	319	225	255	286	319	352	386	421	457	494	523
Medium-Low	132	158	184	211	237	264	292	319	350	374	325	360	392	429	465	500	543	579	615	650
Medium-High	160	189	218	247	277	308	340	373	409	435	456	495	533	559	601	642	684	732	783	809
High	225	255	286	319	352	386	420	457	494	523	605	646	687	728	773	820	865	915	964	1002
Default Cool CFM																				
Low	82	103	124	146	170	194	223	246	270	292	168	197	226	257	287	319	352	386	422	449
Medium-Low	112	134	157	181	205	231	257	285	315	335	250	280	310	342	376	410	443	478	516	544
Medium-High	135	160	186	214	240	268	297	325	357	381	347	384	417	452	494	531	570	607	647	682
High	168	197	227	257	287	319	352	387	422	449	451	492	529	567	606	648	690	736	785	817
Decrease (-10%) Cool CFM																				
Low	65	85	106	127	151	174	197	219	241	263	137	164	190	216	244	271	299	329	360	384
Medium-Low	89	110	132	154	178	201	231	256	281	303	181	211	242	273	305	338	372	404	442	469
Medium-High	112	134	157	181	205	231	257	285	315	335	255	289	325	358	391	426	462	499	536	568
High	137	163	190	216	244	271	299	328	360	384	347	384	417	452	494	531	570	607	647	682

BLOWER DATA

SLP99UH110XV60C BLOWER PERFORMANCE (less filter)

SINGLE SIDE RETURN AIR – Air volumes in **bold** require Optional Return Air Base and field fabricated transition to accommodate 20 x 25 x 1 in. air filter in order to maintain proper air velocity.

HEATING BLOWER PERFORMANCE - 0 through 0.8 in. w.g. External Static Pressure Range

Heating Adjust CFM Selections	Heating Input Range and Blower Volume - CFM							
	35%	40%	50%	60%	70%	80%	90%	100%
Increase (+15%) Heat CFM	733	825	1009	1194	1378	1562	1747	1931
Increase (+7.5%) Heat CFM	708	794	967	1139	1312	1484	1657	1829
Default Heat CFM	683	763	924	1085	1245	1406	1566	1727
Decrease (-7.5%) Heat CFM	632	707	857	1007	1157	1307	1457	1608
Decrease (-15%) Heat CFM	580	650	790	929	1069	1209	1348	1488

COOLING BLOWER PERFORMANCE - 0 through 1.0 in. w.g. External Static Pressure Range

Cooling Adjust CFM Selections	Blower Speed Selections							
	First Stage Cool Speed - cfm				Second Stage Cool Speed - cfm			
	Low	Medium-Low	Medium High	High (Default)	Low	Medium-Low	Medium High	High (Default)
Increase (+10%) Cool CFM	1050	1195	1315	1495	1515	1710	1870	2065
Default Cool CFM	960	1095	1220	1355	1360	1555	1755	1890
Decrease (-10%) Cool CFM	850	985	1095	1220	1215	1400	1555	1755

The effect of static pressure is included in air volumes shown.

The following control configurations are available. See Installation Instructions for details and DIP switch settings.

Heat Modes Available (Heating Blower Performance Table):

Single stage thermostat:

- 35%, 70%, 100% input (three-stage) with time delays in-between.

Two-stage thermostat:

- Variable Rate Capacity Mode - furnace automatically adjusts firing rate based on first- and second-stage cycle times.
- W1 demand at 70% input, W2 demand at 100% input. No delay between stages.

Cool Mode Available (Cooling Blower Performance table):

First stage COOL (two-stage air conditioning units only) is approximately 70% of the same second stage COOL speed position.

Continuous Fan speeds are approximately 28% and 38% (DIP switch selectable) of the same second-stage COOL speed position. minimum 380 cfm.

Lennox® Smart Zoning System Applications - Minimum blower speed is 450 cfm.

SLP99UH110XV60C BLOWER MOTOR WATTS - COOLING

Blower Speed Options	Motor Watts @ Various External Static Pressures - in. wg.																			
	First Stage										Second Stage									
	0	0.1	0.2	0.3	0.4	0.5	0.6	0.7	0.8	0	0.1	0.2	0.3	0.4	0.5	0.6	0.7	0.8	0.9	1.0
Increase (+10%) Cool CFM																				
Low	67	95	124	148	172	212	241	260	287	215	247	287	338	378	412	448	497	535	557	600
Medium-Low	112	140	176	200	232	262	303	323	350	332	360	420	459	500	551	601	636	666	705	747
Medium-High	151	191	221	251	283	321	356	392	431	478	513	560	611	672	701	750	801	843	865	916
High	215	247	287	338	378	412	448	497	535	661	699	751	813	856	901	955	1005	1047	1088	1131
Default Cool CFM																				
Low	53	82	99	128	153	172	199	231	251	156	198	217	270	297	328	371	403	440	474	515
Medium-Low	81	109	136	165	198	229	259	281	307	244	272	327	361	410	446	494	527	564	600	636
Medium-High	113	144	174	209	233	269	304	323	362	387	415	458	513	552	602	644	680	719	763	807
High	156	198	217	270	297	328	371	403	440	505	541	594	624	675	727	780	812	843	886	925
Decrease (-10%) Cool CFM																				
Low	43	62	84	111	125	152	167	189	211	114	137	183	206	235	264	303	330	358	388	417
Medium-Low	62	86	115	134	162	187	219	238	262	165	199	236	281	308	357	381	426	466	492	531
Medium-High	81	109	136	165	198	229	259	281	307	239	269	326	354	413	463	498	523	573	601	656
High	114	137	183	206	235	264	303	330	358	387	415	458	513	552	602	644	680	719	744	776

BLOWER DATA

SLP99UH135XV60D BLOWER PERFORMANCE (less filter)

BOTTOM RETURN AIR

HEATING BLOWER PERFORMANCE - 0 through 0.8 in. w.g. External Static Pressure Range

Heating Adjust CFM Selections	Heating Input Range and Blower Volume - CFM							
	35%	40%	50%	60%	70%	80%	90%	100%
Increase (+15%) Heat CFM	949	1033	1200	1367	1534	1701	1868	2035
Increase (+7.5%) Heat CFM	879	957	1113	1269	1426	1582	1738	1895
Default Heat CFM	808	881	1026	1172	1317	1463	1608	1754
Decrease (-7.5%) Heat CFM	748	817	956	1095	1235	1374	1513	1652
Decrease (-15%) Heat CFM	687	753	886	1019	1152	1284	1417	1550

COOLING BLOWER PERFORMANCE - 0 through 1.0 in. w.g. External Static Pressure Range

Cooling Adjust CFM Selections	Blower Speed Selections							
	First Stage Cool Speed - cfm				Second Stage Cool Speed - cfm			
	Low	Medium-Low	Medium High	High (Default)	Low	Medium-Low	Medium High	High (Default)
Increase (+10%) Cool CFM	1080	1240	1380	1570	1565	1790	2000	2250
Default Cool CFM	995	1130	1250	1415	1415	1615	1825	2010
Decrease (-10%) Cool CFM	900	1025	1130	1255	1265	1460	1640	1825

The effect of static pressure is included in air volumes shown.

The following control configurations are available. See Installation Instructions for details and DIP switch settings.

Heat Modes Available (Heating Blower Performance Table):

Single stage thermostat:

- 35%, 70%, 100% input (three-stage) with time delays in-between.

Two-stage thermostat:

- Variable Rate Capacity Mode - furnace automatically adjusts firing rate based on first- and second-stage cycle times.
- W1 demand at 70% input, W2 demand at 100% input. No delay between stages.

Cool Mode Available (Cooling Blower Performance table):

First stage COOL (two-stage air conditioning units only) is approximately 70% of the same second stage COOL speed position.

Continuous Fan speeds are approximately 28% and 38% (DIP switch selectable) of the same second-stage COOL speed position. minimum 380 cfm.

Lennox® Smart Zoning System Applications - Minimum blower speed is 450 cfm.

SLP99UH135XV60D BLOWER MOTOR WATTS - COOLING

Blower Speed Options	Motor Watts @ Various External Static Pressures - in. wg.																			
	First Stage										Second Stage									
	0.1	0.2	0.3	0.4	0.5	0.6	0.7	0.8	0.9	1.0	0.1	0.2	0.3	0.4	0.5	0.6	0.7	0.8	0.9	1.0
Increase (+10%) Cool CFM																				
Low	99	122	146	170	194	220	247	275	304	325	249	278	308	340	372	404	440	474	509	538
Medium-Low	134	161	188	215	244	274	303	337	372	395	347	383	417	454	491	525	567	603	641	676
Medium-High	176	204	234	264	295	326	359	393	428	455	470	507	547	588	630	673	719	767	818	852
High	249	278	308	339	372	403	440	473	509	538	661	703	745	791	838	890	940	992	1031	N/A
Default Cool CFM																				
Low	82	104	126	148	172	196	222	246	273	294	188	215	244	276	306	338	370	403	437	465
Medium-Low	110	134	158	183	209	235	263	293	323	345	271	300	333	365	396	430	465	502	540	568
Medium-High	137	164	191	218	248	278	309	342	378	401	363	398	434	473	510	547	588	627	668	703
High	188	216	245	276	306	338	370	403	437	465	481	519	558	599	639	681	724	772	821	855
Decrease (-10%) Cool CFM																				
Low	67	87	108	129	151	173	196	220	244	264	139	166	193	221	250	281	312	346	382	405
Medium-Low	88	111	133	157	180	205	230	257	284	305	204	233	263	293	323	356	388	419	455	482
Medium-High	110	134	158	183	209	235	263	293	323	345	278	311	342	374	407	440	476	513	550	579
High	139	166	193	220	250	280	312	345	382	405	363	398	434	473	510	547	588	627	668	703

BLOWER DATA

SLP99UH135XV60D BLOWER PERFORMANCE (less filter)

SINGLE SIDE RETURN AIR – Air volumes in **bold** require Optional Return Air Base and field fabricated transition to accommodate 20 x 25 x 1 in. air filter in order to maintain proper air velocity.

HEATING BLOWER PERFORMANCE - 0 through 0.8 in. w.g. External Static Pressure Range

Heating Adjust CFM Selections	Heating Input Range and Blower Volume - CFM							
	35%	40%	50%	60%	70%	80%	90%	100%
Increase (+15%) Heat CFM	927	1010	1175	1340	1505	1671	1836	2001
Increase (+7.5%) Heat CFM	844	923	1081	1239	1398	1556	1714	1873
Default Heat CFM	760	836	987	1138	1290	1441	1593	1744
Decrease (-7.5%) Heat CFM	703	775	919	1064	1208	1352	1496	1641
Decrease (-15%) Heat CFM	646	715	852	989	1126	1263	1400	1537

COOLING BLOWER PERFORMANCE - 0 through 1.0 in. w.g. External Static Pressure Range

Cooling Adjust CFM Selections	Blower Speed Selections							
	First Stage Cool Speed - cfm				Second Stage Cool Speed - cfm			
	Low	Medium-Low	Medium High	High (Default)	Low	Medium-Low	Medium High	High (Default)
Increase (+10%) Cool CFM	1070	1235	1385	1535	1550	1720	1925	2005
Default Cool CFM	985	1110	1245	1395	1415	1605	1755	1970
Decrease (-10%) Cool CFM	870	1010	1110	1260	1280	1435	1610	1755

The effect of static pressure is included in air volumes shown.

The following control configurations are available. See Installation Instructions for details and DIP switch settings.

Heat Modes Available (Heating Blower Performance Table):

Single stage thermostat:

- 35%, 70%, 100% input (three-stage) with time delays in-between.

Two-stage thermostat:

- Variable Rate Capacity Mode - furnace automatically adjusts firing rate based on first- and second-stage cycle times.
- W1 demand at 70% input, W2 demand at 100% input. No delay between stages.

Cool Mode Available (Cooling Blower Performance table):

First stage COOL (two-stage air conditioning units only) is approximately 70% of the same second stage COOL speed position.

Continuous Fan speeds are approximately 28% and 38% (DIP switch selectable) of the same second-stage COOL speed position. minimum 380 cfm.

Lennox® Smart Zoning System Applications - Minimum blower speed is 450 cfm.

SLP99UH135XV60D BLOWER MOTOR WATTS - COOLING

Blower Speed Options	Motor Watts @ Various External Static Pressures - in. wg.																			
	First Stage										Second Stage									
	0	0.1	0.2	0.3	0.4	0.5	0.6	0.7	0.8	0	0.1	0.2	0.3	0.4	0.5	0.6	0.7	0.8	0.9	1.0
Increase (+10%) Cool CFM																				
Low	77	104	132	154	177	212	238	266	286	223	247	295	331	378	414	448	486	517	539	582
Medium-Low	105	134	170	201	239	276	304	332	360	311	356	397	432	493	522	569	610	663	699	739
Medium-High	155	187	218	261	300	338	370	396	426	438	469	527	590	635	686	729	782	822	865	897
High	216	247	295	331	378	414	448	486	517	507	551	621	671	721	764	828	870	936	973	1015
Default Cool CFM																				
Low	61	86	110	130	149	171	196	224	248	157	187	220	263	306	349	377	410	441	472	507
Medium-Low	89	117	145	172	198	227	252	284	310	248	275	318	369	402	451	478	509	556	579	623
Medium-High	115	146	179	211	242	279	304	340	370	325	365	414	453	504	552	593	641	688	717	759
High	152	187	220	263	306	349	377	410	441	382	428	466	524	576	622	719	719	770	812	852
Decrease (-10%) Cool CFM																				
Low	40	58	83	103	127	147	165	187	204	118	150	177	212	236	281	311	339	361	398	431
Medium-Low	67	90	116	138	160	180	206	236	256	168	200	238	279	323	356	388	429	462	490	539
Medium-High	86	115	142	164	198	224	250	275	310	249	279	328	363	407	448	479	513	560	584	632
High	118	150	177	212	236	281	311	339	361	288	329	365	413	444	493	529	575	604	651	693

REVISIONS

Sections	Description of Change
Dimensions	Updated Furnace/Coil Combined Dimension data for new CK40 coils.
Override Accessories	Added Refrigerant Detection System (RDS) Components.



Visit us at www.Lennox.com

For the latest technical information, www.LennoxPros.com

Contact us at 1-800-9-LENNOX

NOTE - Due to Lennox' ongoing commitment to quality, Specifications, Ratings and Dimensions subject to change without notice and without incurring liability. Improper installation, adjustment, alteration, service or maintenance can cause property damage or personal injury. Installation and service must be performed by a qualified installer and servicing agency.

©2024 Lennox Industries, Inc.