



# HCWP3

## Healthy Climate® Power Humidifier - 60Hz

### RESIDENTIAL PRODUCT SPECIFICATIONS

Bulletin No. 210544  
September 2011  
Supersedes May 2011

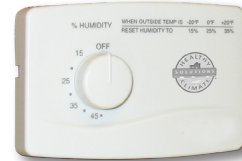

Manual Humidistat  
(furnished with standard Models)



Automatic Humidifier Control  
(furnished with "A" Models)

### MODEL NUMBER IDENTIFICATION

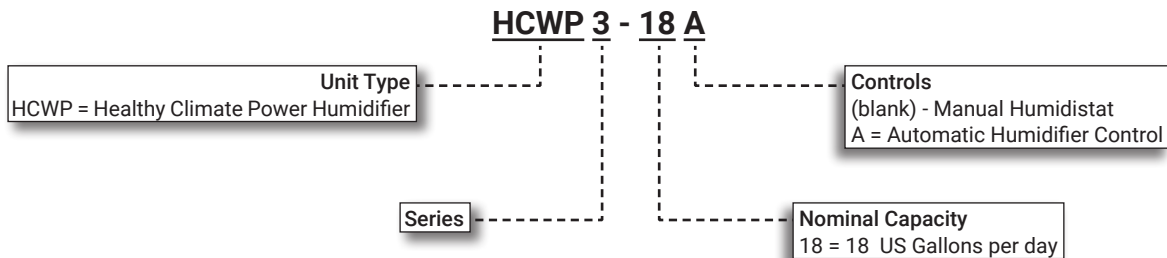

## CONTENTS

Approvals And Warranty . . . . .	2
Dimensions . . . . .	5
Features . . . . .	2
Humidifier Sizing Information . . . . .	4
Typical Applications . . . . .	5

## APPROVALS AND WARRANTY

### APPROVALS

- UL listed per ANSI/UL 998 and CSA C22.2 No.104-01

### WARRANTY

- All covered components:
  - Limited five years warranty in residential applications
  - Limited one-year in non-residential applications

**NOTE** - Refer to Lennox Equipment Limited Warranty certificate included with unit for specific details.

## FEATURES

### APPLICATIONS

- Installs on the supply air plenum
- May be installed on the return air plenum if hot water (maximum 120°F continuous and 140°F intermittent) is supplied to humidifier
- Applicable to most forced air installations
- Not for installation in horizontal supply ducts in horizontal applications
- Do not install where freezing may occur
- Provides additional humidity to the home during the heating season to increase comfort level
- Humidifier, saddle valve and manual or automatic humidifier control (depending on model) shipped in one package

### SEQUENCE OF OPERATION

- Humidifier will only operate when indoor blower is operating
- When the level of moisture in the return air or living space area drops below the set point of the humidifier control, the water solenoid valve opens
- Water flows into a distribution tray and weeps down through evaporator pad
- Fan draws air in through the moistened evaporator pad and forces the humidified air back into supply air stream
- When the humidifier control is satisfied, the water solenoid valve closes and the fan turns off

### CABINET

- Rugged, corrosion resistant molded plastic
- Motor and electrical service access located on front of cabinet in separate compartment
- Front of unit lifts off to access the evaporator pad and internal plumbing

### MOTOR

- Thermally protected
- Permanently lubricated for long life
- Factory installed in molded plastic housing for protection against moisture

### CONTROLS

#### **Manual Humidistat - HCWP3-18 models**

- Can be horizontally mounted on wall or duct
- Provides manual control of room relative humidity
- Wired in series with the humidifier water solenoid valve
- Adjustable setting

#### **Automatic Humidifier Control - HCWP3-18A models**

- Duct mount only
- Automatic or manual mode control
- Manual Mode label (with resistor to bypass outdoor temperature sensor) is furnished to indicate when humidistat is installed in Manual Mode
- Senses duct air relative humidity and outdoor temperature
- Includes outdoor temperature sensor for use with automatic control option and resistor for manual control setting
- Adjusts humidity setpoint to provide optimum humidity levels within the space
- Adjustable setting

## FEATURES

### WATER SUPPLY SYSTEM

- Consists of supply tubing, orifice, distribution tray, cleanable/replaceable internal strainer and 24 volt brass water solenoid valve with stainless steel seat

### Distribution Tray

- Deep reservoir and unique polyester liner provides even water distribution across the evaporator media pad for optimal performance
- Tray and support frame removable for cleaning or replacement

### Evaporator Media Pad

- Provides large evaporation capacity
- Pad and support frame removable for cleaning or replacement

**NOTE** - Annual pad replacement recommended.

### Drain

- 1/2 in. drain fitting at bottom of cabinet

**NOTE** - 1/2 in. ID plastic tubing must be field provided

- Unused water from the evaporator pad is drained from the unit to help remove mineral deposits left from the evaporative process

### Saddle Valve

- All necessary fittings furnished as standard equipment.
- Field installs in the water supply line.

### Optional Accessories

#### Healthy Climate® Digital Automatic Humidistat

- Basic humidity control (on/off or proportional) and temperature display
- Control Buttons:
  - Power button
  - °F/°C display
  - Set button for changing humidity setpoints
  - SLEEP button for changing day/night modes
  - PRG button for programming timed settings and setting the clock
  - Up/Down buttons to change humidity setpoint and time
- Built-in humidity sensor
- Outdoor temperature sensor furnished
- 24VAC powered directly by the humidifier
- LCD with alphanumeric characters and icon graphics:
  - Humidity and Temperature (indoor/outdoor)
  - Humidity Mode
  - Sleep Mode
  - Auto Mode
  - Lock Mode
  - Program Timer On



- Large LCD display shows humidity (or temperature) setpoint while the small display shows temperature (or time) setpoint
- Built-in clock (with backup) for automatic humidity control
- Two time settings per day
- Error code display
- Lock mode indicates a parameter has been set
- Dimension (H x W x D): 3-3/8 x 5-1/2 x 1-3/8 in.

#### Healthy Climate® Water Conductivity Test Kit

- A conductivity meter is recommended for testing the water
- Measures total dissolved solids (TDS) and temperature
- Automatic Temperature Compensation (ATC)
- Water-resistant housing
- Measurement Range: 0-5000 ppm
- Digital Calibration (Push button)
- Auto-off function, data-hold function and low-battery indicator
- Display - Large and easy-to-read LCD screen includes simultaneous temperature reading
- Factory-calibrated with a 342 ppm NaCl solution
- The meter can be recalibrated with digital calibration using the Push buttons, rather than a screwdriver
- Includes cap and CR2032 battery



### MAINTENANCE SUPPLIES

#### Replacement Media

- Recommended annual replacement of media pad

## SPECIFICATIONS

<b>Model No.</b>	With Manual Humidistat Control	<b>HCWP3-18</b>
	With Automatic Humidifier Control	<b>HCWP3-18A</b>
Capacity	Plenum Air Temperature	120°F
	US Gallons per day	18
Water Feed Rate (gallons per hour @ 50 PSI water pressure)		6
Evaporator pad size - H x W x D - in.		13 x 10 x 1-11/16
Connections	Plenum H x W - in.	14-5/16 x 14-3/4
	Water supply	1/4 in. compression
	Drain	1/2 in. I.D.
	Electrical	Power cord with 3 prong plug
Electrical characteristics		120V - 60hz - 1ph, 0.8 amp
Shipping Data - lbs. (1 package)		15
<b>MAINTENANCE SUPPLIES - MUST BE ORDERED EXTRA</b>		
Replacement Media		<b>X2661</b>
<b>OPTIONAL ACCESSORIES - MUST BE ORDERED EXTRA</b>		
Healthy Climate® Digital Automatic Humidistat		<b>Y3760</b>
Healthy Climate® Water Conductivity Test Kit		<b>Y3480</b>

## HUMIDIFIER SIZING INFORMATION

### (BASED ON VOLUME OF HOME)

Model No.	Type of Home	8 Foot Ceiling	9 Foot Ceiling	10 Foot Ceiling
		Home Area (sq. ft.)	Home Area (sq. ft.)	Home Area (sq. ft.)
HCWP3-18, HCWP3-18A	Loose Home	1050	930	840
	Average Home	2100	1900	1700
	Tight Home	4200	3800	3400

#### NOTES:

Loose Home = Two Air Change Rates per hour: Typically, loose in construction and is over 20 years old. Not very well insulated and may have single pane windows, etc.

Average Home = One Air Change Rate per hour: Average in construction, 15 to 20 years old on average.

Tight Home = One-Half Air Change Rate per hour: Newer home with tight construction.

Also see Healthy Climate Bypass Humidifier HCWB3 Product Specifications for additional sizing conditions if needed.

## DIMENSIONS

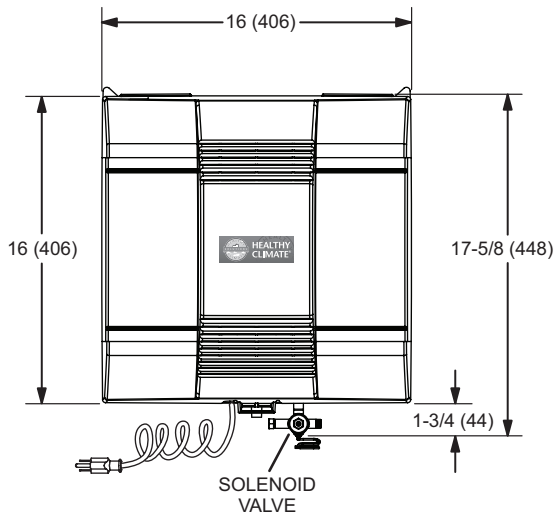

**FRONT VIEW**

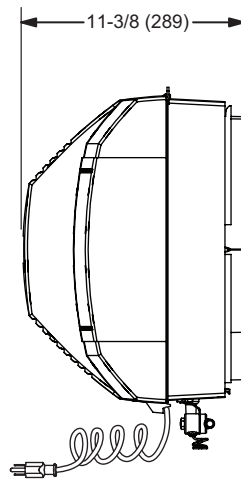

**RIGHT SIDE VIEW**

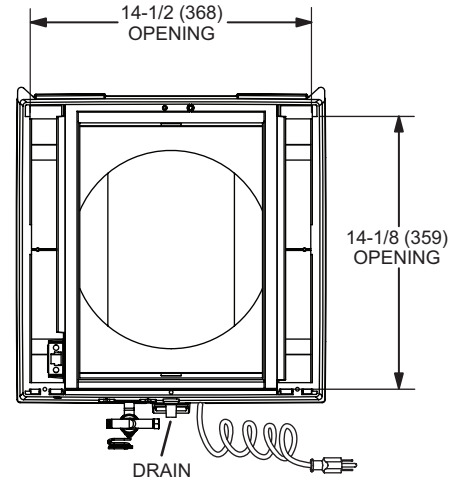

**BACK VIEW**

## TYPICAL APPLICATIONS

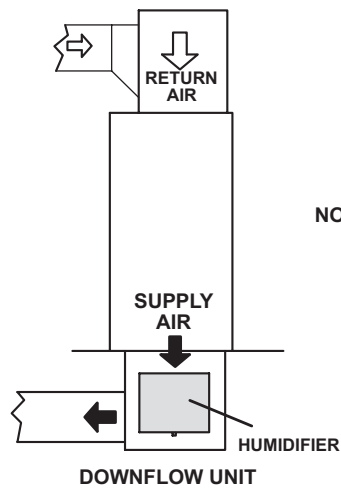
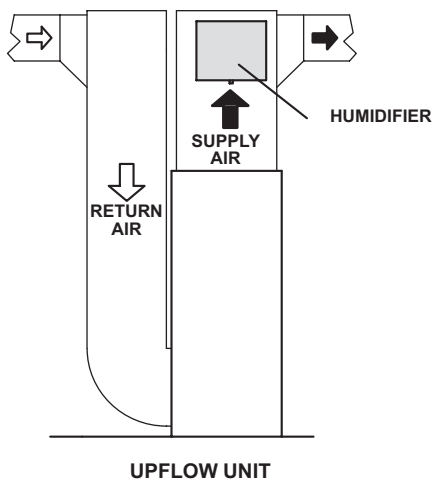

**NOTE - Not for installation in horizontal supply ducts in horizontal applications.**





## REVISIONS

Sections	Description of Change
Optional Accessories	Added Healthy Climate® Digital Automatic Humidistat and Healthy Climate® Water Conductivity Test Kit.



Visit us at [www.lennox.com](http://www.lennox.com)

For the latest technical information, [www.LennoxPros.com](http://www.LennoxPros.com)

Contact us at 1-800-4-LENNOX

NOTE - Due to Lennox' ongoing commitment to quality, Specifications, Ratings and Dimensions subject to change without notice and without incurring liability. Improper installation, adjustment, alteration, service or maintenance can cause property damage or personal injury. Installation and service must be performed by a qualified installer and servicing agency.

©2011 Lennox Industries, Inc.