

**EL19KPV (R454B) SERIES OUTDOOR UNITS**



**Table of Contents**

Model Number Identification.....	6
Typical Serial Number Identification .....	6
Specifications .....	7
Electrical Data .....	7
Unit Dimensions – Inches (mm) .....	8
Typical Unit Parts Arrangement .....	9
Operating Gauge Set and Service Valves.....	11
Installation .....	13
Unit Placement .....	13
Removing and Installing Panels .....	16
New or Replacement Line Set.....	17
Brazing Connections .....	21
Flushing Line Set and Indoor Coil .....	24
Leak Testing the System .....	26
Evacuating Line Set and Indoor Coil .....	28
Unit Operation .....	36
Defrost Function .....	36
Defrost Test .....	38
Unit Start-Up .....	41
System Operation and Service .....	42
Unit Selection Code for Outdoor Control .....	49
Configuring Unit.....	52
Reconfiguring Outdoor Control Using S40 Thermostat	53
System Overview.....	53
Diagnostic Information - Installations with S40 Thermostat.....	53
Installer Test - Installations with S40 Thermostat .....	53
Maintenance.....	54
Unit Wiring Diagrams.....	55
Factory Wiring Diagrams .....	56
Unit Sequence of Operation .....	58
Component Testing.....	62
System Configuration .....	75
Unit Operation .....	76
6-Pin Sensor Harness (LIQ, AMB, COIL) .....	77
4-Pin Suction Temperature Sensor / Liquid Temperature Sensor Harness .....	77
System Refrigerant.....	85
Charge Mode Jumper .....	85
Charging .....	85
Decommissioning .....	91

**⚠ WARNING**

Improper installation, adjustment, alteration, service or maintenance can cause property damage, personal injury or loss of life. Installation and service must be performed by a licensed professional HVAC installer or equivalent, service agency, or the gas supplier.

**⚠ IMPORTANT**

The Clean Air Act of 1990 bans the intentional venting of refrigerant (CFCs, HCFCs and HFCs) as of July 1, 1992. Approved methods of recovery, recycling or reclaiming must be followed. Fines and/or incarceration may be levied for noncompliance.

**⚠ IMPORTANT**

This unit must be matched with an indoor coil as specified in Lennox Product Specification bulletin. Coils previously charged with HCFC-22 must be flushed.

**⚠ CAUTION**

As with any mechanical equipment, contact with sharp sheet metal edges can result in personal injury. Take care while handling this equipment and wear gloves and protective clothing.

**⚠ WARNING**

To prevent serious injury or death:

1. Lock-out/tag-out before performing maintenance.
2. If system power is required (e.g., smoke detector maintenance), disable power to blower, remove fan belt where applicable, and ensure all controllers and thermostats are set to the "OFF" position before performing maintenance.
3. Always keep hands, hair, clothing, jewelry, tools, etc. away from moving parts.

**⚠ IMPORTANT**

This unit must be matched with an indoor coil as specified with AHRI. For AHRI Certified system match-ups and expanded ratings, visit [www.LennoxPros.com](http://www.LennoxPros.com).

## **WARNING**

- Do not use means to accelerate the defrosting process or to clean, other than those recommended by the manufacturer.
- The appliance shall be stored in a room without continuously operating ignition sources (for example: open flames, an operating gas appliance, or an operating electric heater).
- Do not pierce or burn.
- Be aware that refrigerants may not contain an odor.

## **CAUTION**

Servicing shall be performed only as recommended by the manufacturer.

## **WARNING**

Ducts connected to an appliance shall not contain a potential ignition source

## **WARNING**

Every working procedure that affects safety means shall only be carried out by competent persons. This appliance is not to be used by persons (including children) with reduced physical, sensory or mental capabilities, or lack of experience and knowledge, unless they have been given supervision or instruction concerning use of the appliance by a person responsible for their safety. Children should be supervised to ensure they do not play with the appliance.

## **IMPORTANT**

Ensure that the area is in the open or that it is adequately ventilated before breaking into the system or conducting any hot work. A degree of ventilation shall continue during the period that the work is carried out.

## **IMPORTANT**

Verify cabling will not be subject to wear, corrosion, excessive pressure, vibration, sharp edges or any other adverse environmental effects.

## **IMPORTANT**

Pipe work, including piping material, pipe routing, and installation shall include protection from physical damage in operation and service, and be in compliance with national and local codes and standards, such as ASHRAE 15, ASHRAE 15.2, IAPMO Uniform Mechanical Code, ICC International Mechanical Code, or CSA B52. All field joints shall be accessible for inspection prior to being covered or enclosed.

## **CAUTION**

Under no circumstances shall potential sources of ignition be used in the searching for or detection of refrigerant leaks. A halide torch (or any other detector using a naked flame) shall not be used.

The following leak detection methods are deemed acceptable for all refrigerant systems.

Electronic leak detectors may be used to detect refrigerant leaks but, in the case of flammable refrigerants, the sensitivity may not be adequate, or may need recalibration. (Detection equipment shall be calibrated in a refrigerant-free area.) Ensure that the detector is not a potential source of ignition and is suitable for the refrigerant used. Leak detection equipment shall be set at a percentage of the LFL of the refrigerant and shall be calibrated to the refrigerant employed, and the appropriate percentage of gas (25 % maximum) is confirmed. Leak detection fluids are also suitable for use with most refrigerants but the use of detergents containing chlorine shall be avoided as the chlorine may react with the refrigerant and corrode the copper pipe-work. If a leak is suspected, all naked flames shall be removed/extinguished. If a leakage of refrigerant is found which requires brazing, all of the refrigerant shall be recovered from the system, or isolated (by means of shut off valves) in a part of the system remote from the leak.

## **CAUTION**

Some soaps used for leak detection are corrosive to certain metals. Carefully rinse piping thoroughly after leak test has been completed. Do not use matches, candles, flame or other sources of ignition to check for gas leaks.

## **WARNING**

PARTIAL UNITS shall only be connected to an appliance suitable for the same refrigerant.

## **⚠ IMPORTANT**

When breaking into the refrigerant circuit to make repairs – or for any other purpose – conventional procedures shall be used. However, for flammable refrigerants it is important that best practice be followed and, since flammability is a consideration, procedures such as safely remove refrigerant following local and national regulations, purging the circuit with inert gas, evacuating (optional for A2L), purging with inert gas (optional for A2L), or opening the circuit by cutting or brazing be adhered to. The refrigerant charge shall be recovered into the correct recovery cylinders if venting is not allowed by local and national codes. For appliances containing flammable refrigerants, the system shall be purged with oxygen-free nitrogen to render the appliance safe for flammable refrigerants.

This process might need to be repeated several times. Compressed air or oxygen shall not be used for purging refrigerant systems. For appliances containing flammable refrigerants, refrigerants purging shall be achieved by breaking the vacuum in the system with oxygen-free nitrogen and continuing to fill until the working pressure is achieved, then venting to atmosphere, and finally pulling down to a vacuum (optional for A2L). This process shall be repeated until no refrigerant is within the system (optional for A2L). When the final oxygen-free nitrogen charge is used, the system shall be vented down to atmospheric pressure to enable work to take place. Ensure that the outlet for the vacuum pump is not close to any potential ignition sources and that ventilation is available.

## **⚠ IMPORTANT**

In addition to conventional charging procedures, the following requirements shall be followed.

- Ensure that contamination of different refrigerants does not occur when using charging equipment. Hoses or lines shall be as short as possible to minimize the amount of refrigerant contained in them.
- Cylinders shall be kept in an appropriate position according to the instructions.
- Ensure that the REFRIGERATING SYSTEM is earthed prior to charging the system with refrigerant.
- Label the system when charging is complete (if not already).
- Extreme care shall be taken not to overfill the REFRIGERATING SYSTEM.

Prior to recharging the system, it shall be pressure-tested with the appropriate purging gas. The system shall be leak tested on completion of charging, but prior to commissioning. A follow up leak test shall be carried out prior to leaving the site.

## **⚠ IMPORTANT**

When removing refrigerant from a system, either for servicing or decommissioning, it is recommended good practice that all refrigerants are removed safely.

When transferring refrigerant into cylinders, ensure that only appropriate refrigerant recovery cylinders are employed. Ensure that the correct number of cylinders for holding the total system charge is available. All cylinders to be used are designated for the recovered refrigerant and labelled for that refrigerant (i. e. special cylinders for the recovery of refrigerant). Cylinders shall be complete with pressure-relief valve and associated shut-off valves in good working order. Empty recovery cylinders are evacuated and, if possible, cooled before recovery occurs.

The recovery equipment shall be in good working order with a set of instructions concerning the equipment that is at hand and shall be suitable for the recovery of all appropriate refrigerants including, when applicable, flammable refrigerants. In addition, a set of calibrated weighing scales shall be available and in good working order. Hoses shall be complete with leak-free disconnect couplings and in good condition. Before using the recovery machine, check that it is in satisfactory working order, has been properly maintained and that any associated electrical components are sealed to prevent ignition in the event of a refrigerant release. Consult manufacturer if in doubt.

The recovered refrigerant shall be returned to the refrigerant supplier in the correct recovery cylinder, and the relevant waste transfer note arranged. Do not mix refrigerants in recovery units and especially not in cylinders.

If compressors or compressor oils are to be removed, ensure that they have been evacuated to an acceptable level to make certain that flammable refrigerant does not remain within the lubricant. The evacuation process shall be carried out prior to returning the compressor to the suppliers. Only electric heating to the compressor body shall be employed to accelerate this process. When oil is drained from a system, it shall be carried out safely.

## **⚠ IMPORTANT**

After completion of field piping for split systems, the field pipework shall be pressure tested with an inert gas and then vacuum tested prior to refrigerant charging, according to the following requirements;

– Field-made refrigerant joints indoors shall be tightness tested. The test method shall have a sensitivity of .2 oz. per year of refrigerant or better, under pressure.

No leak shall be detected.

**⚠ IMPORTANT**

Prior to beginning work on systems containing **FLAMMABLE REFRIGERANTS**, safety checks are necessary to ensure that the risk of ignition is minimized.

**⚠ IMPORTANT**

Work shall be undertaken under a controlled procedure so as to minimize the risk of a flammable gas or vapor being present while the work is being performed.

**⚠ IMPORTANT**

All maintenance staff and others working in the local area shall be instructed on the nature of work being carried out. Work in confined spaces shall be avoided.

**⚠ IMPORTANT**

The area shall be checked with an appropriate refrigerant detector prior to and during work, to ensure the technician is aware of potentially toxic or flammable atmospheres. Ensure that the leak detection equipment being used is suitable for use with all applicable refrigerants, i.e. non-sparking, adequately sealed or intrinsically safe.

**⚠ IMPORTANT**

If any hot work is to be conducted on the refrigerating equipment or any associated parts, appropriate fire extinguishing equipment shall be available to hand. Have a dry powder or CO<sup>2</sup> fire extinguisher adjacent to the charging area.

**⚠ IMPORTANT**

No person carrying out work in relation to a **REFRIGERATING SYSTEM** which involves exposing any pipe work shall use any sources of ignition in such a manner that it may lead to the risk of fire or explosion. All possible ignition sources, including cigarette smoking, should be kept sufficiently far away from the site of installation, repairing, removing and disposal, during which refrigerant can possibly be released to the surrounding space. Prior to work taking place, the area around the equipment is to be surveyed to make sure that there are no flammable hazards or ignition risks. "No Smoking" signs shall be displayed.

**⚠ IMPORTANT**

Where electrical components are being changed, they shall be fit for the purpose and to the correct specification. At all times the manufacturer's maintenance and service guidelines shall be followed. If in doubt, consult the manufacturer's technical department for assistance.

The following checks shall be applied to installations using **FLAMMABLE REFRIGERANTS**:

- the actual **REFRIGERANT CHARGE** is in accordance with the room size within which the refrigerant containing parts are installed;
- the ventilation machinery and outlets are operating adequately and are not obstructed;
- if an indirect refrigerating circuit is being used, the secondary circuit shall be checked for the presence of refrigerant;
- marking to the equipment continues to be visible and legible. Markings and signs that are illegible shall be corrected;
- refrigerating pipe or components are installed in a position where they are unlikely to be exposed to any substance which may corrode refrigerant containing components, unless the components are constructed of materials which are inherently resistant to being corroded or are suitably protected against being so corroded.

**⚠ IMPORTANT**

Sealed electrical components shall be replaced.

**⚠ IMPORTANT**

Intrinsically safe components must be replaced.

**NOTE** – R-454B is an A2L refrigerant. The system installation must meet the following parameters based upon total refrigerant charge (line set included). *T<sub>Amin</sub>* (Total minimum conditioned area) is the minimum allowable conditioned area based upon the total system charge at sea level. Values must be multiplied by altitude adjustment factor at installed altitude.

*Q<sub>min</sub>* table refers to minimum airflow requirements during refrigerant leak mitigation by the refrigerant detection system, based upon total system charge.

See tables below.

**T<sub>Amin</sub> Table**

Charge (lb)	10.0	15.0	20.0	25.0	30.0
Charge (kg)	4.5	6.8	9.1	11.3	13.6
Minimum Conditioned Area (ft <sup>2</sup> )	149.9	224.9	299.9	374.8	449.8
Minimum Conditioned Area (m <sup>2</sup> )	13.9	20.9	27.9	34.8	41.8

**NOTE** – Multiply values in *T<sub>Amin</sub>* table by the Altitude Adjustment Factors to correct *T<sub>Amin</sub>* based on installed altitude.

**Altitude Adjustment Factor**

<b>Altitude (m)</b>	0	200	400	600	800	1000	1200	1400	1600
<b>Altitude (ft)</b>	0	660	1310	1970	2620	3280	3940	4590	5250
<b>Adj. Factor</b>	1	1	1	1	1.02	1.05	1.04	1.1	1.12
<b>Altitude (m)</b>	1600	1800	2000	2200	2400	2600	2800	3000	3200
<b>Altitude (ft)</b>	5250	5910	6560	7220	7870	8530	9190	9840	10500
<b>Adj. Factor</b>	1.12	1.15	1.18	1.21	1.25	1.28	1.32	1.36	1.4

**Q<sub>min</sub> Table**

<b>Refrigerant Charge lb (kg)</b>	<b>CFM Required</b>	<b>Refrigerant Charge lb (kg)</b>	<b>CFM Required</b>
5 (2.3)	135	18 (8.1)	487
6 (2.7)	162	19 (8.6)	514
7 (3.2)	189	20 (9.1)	541
8 (3.6)	216	21 (9.5)	568
9 (4.1)	244	22 (10)	595
10 (4.5)	271	23 (10.4)	622
11 (5)	298	24 (10.9)	649
12 (5.4)	325	25 (11.3)	676
13 (5.9)	352	26 (11.7)	704
14 (6.4)	379	27 (12.2)	731
15 (6.8)	406	28 (12.7)	758
16 (7.3)	433	29 (13.2)	785
17 (7.7)	460	30 (13.6)	812

## General Information

These instructions are intended as a general guide and do not supersede national or local codes in any way. Consult authorities having jurisdiction before installation.

The EL19KPV is a high-efficiency split system air conditioner **with all-aluminum coil**, designed for use with R454B refrigerant only.

The EL19KPV units feature a variable capacity rotary compressor.

This unit must be installed with an approved indoor air handler or coil. See the Lennox EL19KPV Product Specifications bulletin (EHB) for approved indoor component match ups. These instructions are intended as a general guide and do not supersede local codes in any way. Consult authorities having jurisdiction before installation.

This outdoor unit is designed for use in systems that use the following refrigerant metering device:

- Check thermal expansion valve (CTXV)

**IMPORTANT:** Special procedures are required for cleaning the all-aluminum coil in this unit.

## WARNING



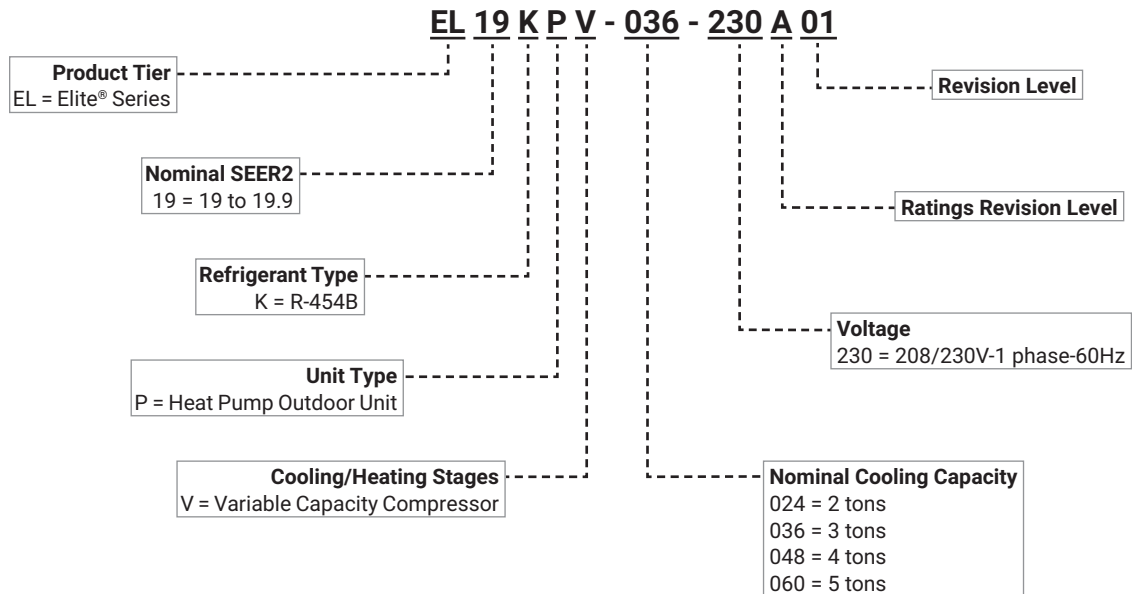
Electrical Hazard

High Voltage

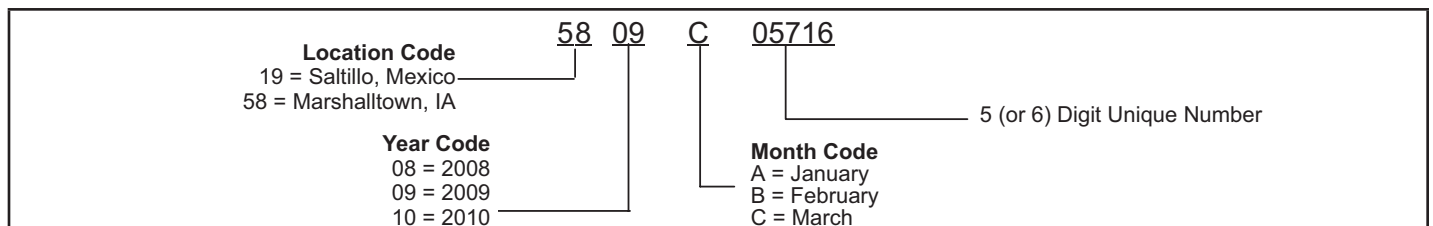
Wait 7 Minutes

Electrical components may hold charge. Do not remove this panel or service this area for 5 minutes after the power has been removed.

## Model Number Identification



## Typical Serial Number Identification



## Specifications

Size		024	036	048	060	
Nominal Tonnage		2	3	4	5	
Sound Rating Number Range	dBa	62-71	61-73	67-76	64-77	
Connections (Sweat)	Liquid line (OD) - in.	3/8	3/8	3/8	3/8	
	Vapor line (OD) - in.	3/4	7/8	7/8	1-1/8	
Compressor Type		Variable Rotary	Variable Rotary	Variable Rotary	Variable Rotary	
Refrigerant (15 ft. Line Set)	<sup>1</sup> R-454B charge furnished	8 lbs. 6 oz.	7 lbs. 15 oz.	8 lbs. 13 oz.	9 lb. 5 oz.	
Refrigerant (30 ft. Line Set)	<sup>1</sup> R-454B charge furnished	8 lbs. 15 oz.	8 lbs. 8 oz.	9 lbs. 6 oz.	9 lbs. 14 oz.	
Indoor Unit Expansion Valve (TXV)		<b>26Z70</b>	<b>26Z70</b>	<b>26Z71</b>	<b>26Z72</b>	
Outdoor Coil	Net face area - ft. <sup>2</sup>	Outer coil	17.00	17.00	23.63	23.63
		Inner coil	16.25	16.25	22.79	22.79
	Tube diameter - in.	5/16	5/16	5/16	5/16	
	Rows	2	2	2	2	
	Fins - in.	22	22	22	22	
Outdoor Fan	HP	1/3	1/3	1/3	1/3	
	Diameter - in.	22	22	22	22	
	Blades	4	4	4	4	
	Cfm	2642	2642	4350	3907	
	Rpm	681	681	1050	941	
	Watts	284	284	425	295	
Shipping Data - lbs.		224	224	269	269	

## Electrical Data

	Line voltage data (Volts-Phase-Hz)	208/230-1-60	208/230-1-60	208/230-1-60	208/230-1-60
	<sup>2</sup> Maximum overcurrent protection (MOCP) amps	25	35	50	60
	<sup>3</sup> Minimum circuit ampacity (MCA)	17.7	23	33.1	39.2
Compressor	Input amps	12.1	16.3	24.4	28.5
Fan Motor	Full load amps	2.6	2.6	2.6	3.6
<b>OPTIONAL CONTROLS - ORDER SEPARATELY</b>					
S40 Smart Wi-Fi Thermostat	<b>22V24</b>	•	•	•	•
E30 Smart Wi-Fi Thermostat	<b>20A65</b>	•	•	•	•
<sup>4</sup> Discharge Air Temperature Sensor	<b>88K38</b>	•	•	•	•
<b>OPTIONAL ACCESSORIES - ORDER SEPARATELY</b>					
Freezestat	3/8 in. <b>93G35</b>	•	•	•	•
Indoor Blower Off Delay Relay	<b>58M81</b>	•	•	•	•
Refrigerant Line Sets	3/8 x 3/4   3/8   20 ft.	<b>89J56</b>			
	3/8 x 3/4   3/8   30 ft.	<b>89J57</b>	•		
	Liquid x Suction OD   3/8 x 3/4   3/8   40 ft.	<b>89J58</b>			
	Insulation Thickness   3/8 x 3/4   3/8   50 ft.	<b>89J59</b>			
	3/8 x 7/8   3/8   30 ft.	<b>89J60</b>			
	3/8 x 7/8   3/8   40 ft.	<b>89J61</b>		•	•
	3/8 x 7/8   3/8   50 ft.	<b>89J62</b>			
	3/8 x 1-1/8   3/8   50 ft.	<b>73P91</b>			•
<sup>5</sup> Snow Guard	35-1/2 x 31 in. <b>X8780</b>	•	•	•	•

NOTE - Extremes of operating range are plus 10% and minus 5% of line voltage.

<sup>1</sup> Refrigerant charge sufficient for 15 ft. length of refrigerant lines. For longer line set requirements see the Installation Instructions for information about line set length and additional refrigerant charge required.

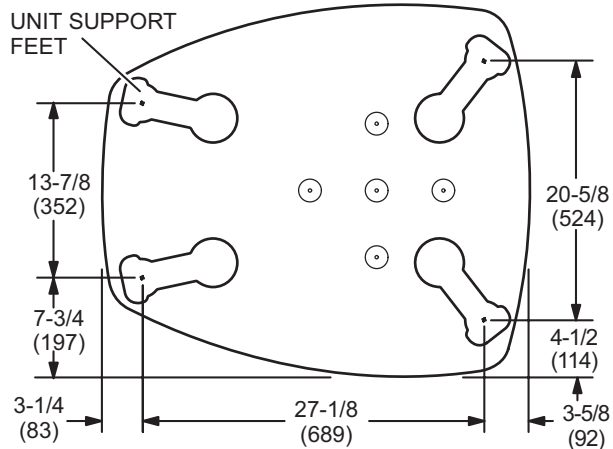
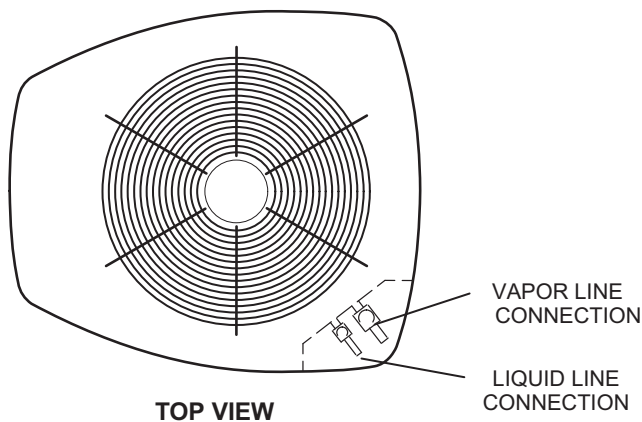
<sup>2</sup> HACR type breaker or fuse.

<sup>3</sup> Refer to National or Canadian Electrical Code manual to determine wire, fuse and disconnect size requirements.

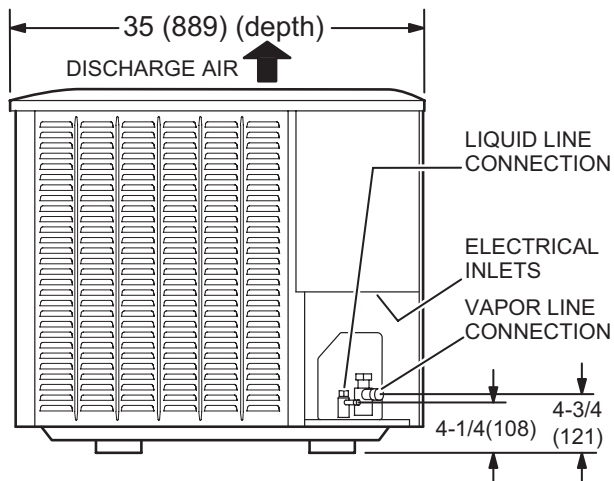
<sup>4</sup> Used with the S40 Smart Wi-Fi Thermostat for optional service diagnostics.

<sup>5</sup> Adds 11-1/2 inches (292 mm) to unit height.

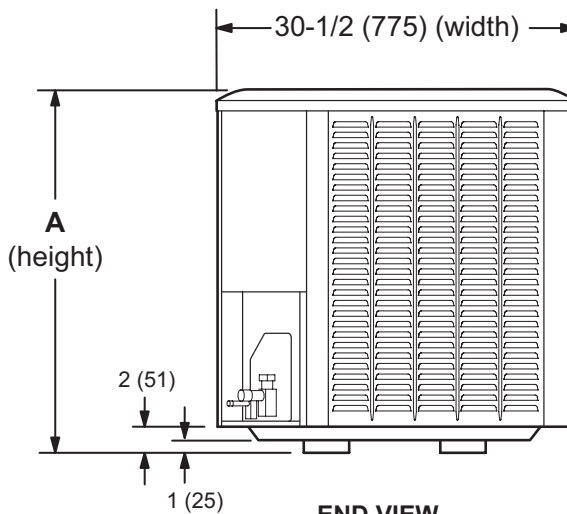
# Unit Dimensions – Inches (mm)



**BASE SECTION  
(Medium Base)**



**SIDE VIEW**



**END VIEW**

Size	A (Height)	
	in.	mm
024	39	991
036	39	991
048	45	1143
060	45	1143



# Typical Unit Parts Arrangement

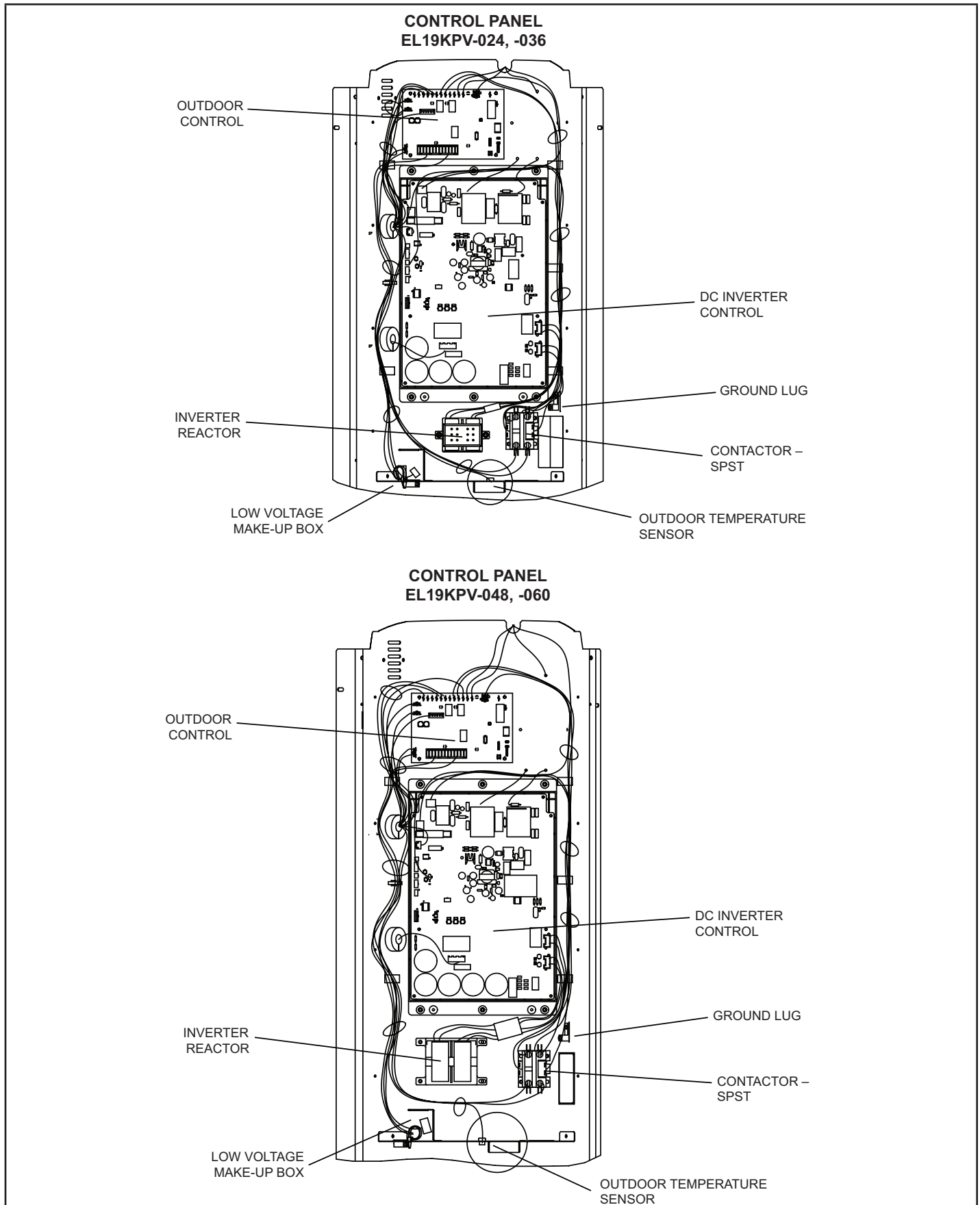
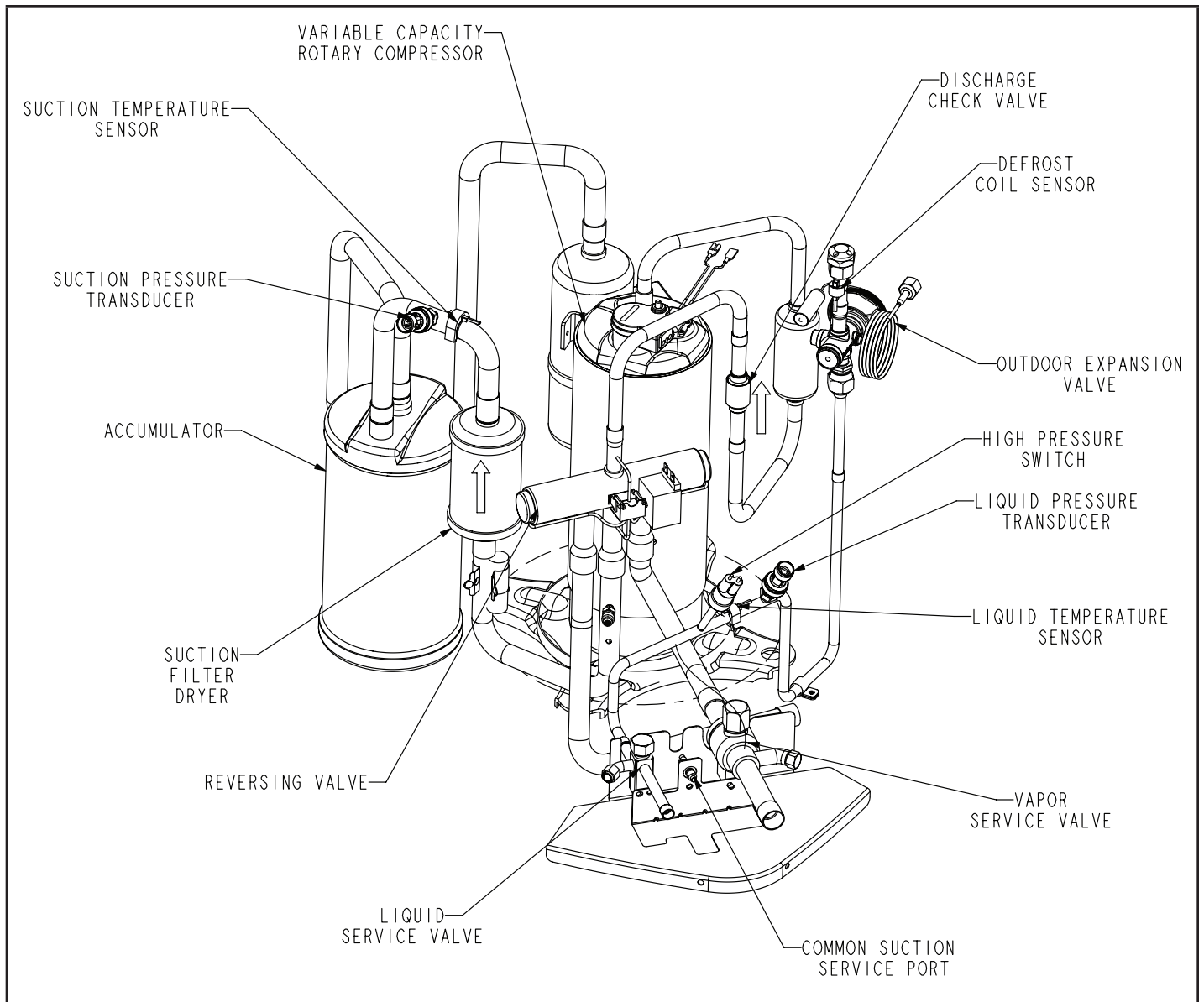


FIGURE 1. Control Panel Components



**FIGURE 2. Component Locations**

## Operating Gauge Set and Service Valves

### TORQUE REQUIREMENTS

When servicing or repairing heating, ventilating, and air conditioning components, ensure the fasteners are appropriately tightened. Table 1 lists torque values for fasteners.

### IMPORTANT

Only use Allen wrenches of sufficient hardness (50Rc - Rockwell Harness Scale minimum). Fully insert the wrench into the valve stem recess.

Service valve stems are factory-torqued (from 9 ft-lbs for small valves, to 25 ft-lbs for large valves) to prevent refrigerant loss during shipping and handling. Using an Allen wrench rated at less than 50Rc risks rounding or breaking off the wrench, or stripping the valve stem recess.

See the Lennox Service and Application Notes #C-08-1 for further details and information.

### IMPORTANT

To prevent stripping of the various caps used, the appropriately sized wrench should be used and fitted snugly over the cap before tightening.

TABLE 1. Torque Requirements

Parts	Recommended Torque	
Service valve cap	8 ft.- lb.	11 NM
Sheet metal screws	16 ft.- lb.	2 NM
Machine screws #10	28 ft.- lb.	3 NM
Compressor bolts	90 in.- lb.	10 NM
Gauge port seal cap	8 ft.- lb.	11 NM

### USING MANIFOLD GAUGE SET

When checking the system charge, only use a manifold gauge set that features low loss anti-blow back fittings.

Manifold gauge set used with R454B refrigerant systems must be capable of handling the higher system operating pressures. The gauges should be rated for use with pressures of 0 - 800 psig on the high side and a low side of 30" vacuum to 250 psig with dampened speed to 500 psi. Gauge hoses must be rated for use up to 800 psig of pressure with a 4000 psig burst rating.

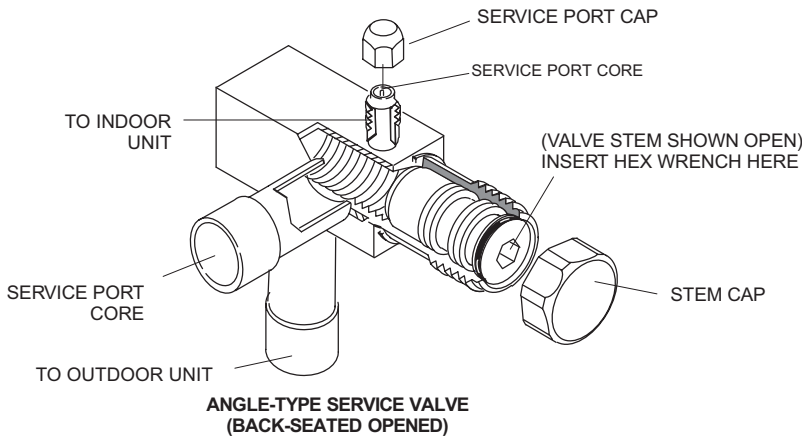
### OPERATING SERVICE VALVES

The liquid and vapor line service valves are used for removing refrigerant, flushing, leak testing, evacuating, checking charge and charging. Each valve is equipped with a service port which has a factory-installed valve stem. Figure 4 provides information on access and operation of both angle and ball service valves

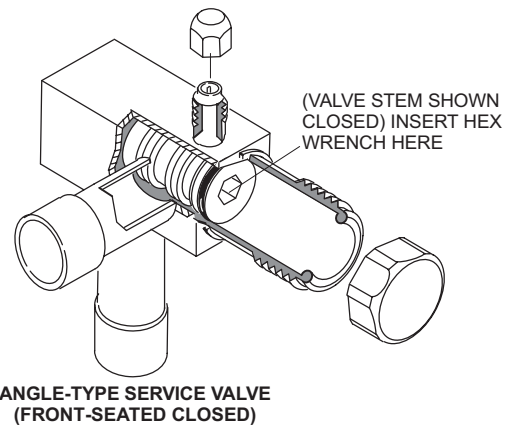
# SERVICE VALVES ANGLE AND BALL

## Operating Angle Type Service Valve:

1. Remove stem cap with an appropriately sized wrench.
2. Use a service wrench with a hex-head extension (3/16" for liquid line valve sizes and 5/16" for vapor line valve sizes) to back the stem out counterclockwise as far as it will go.



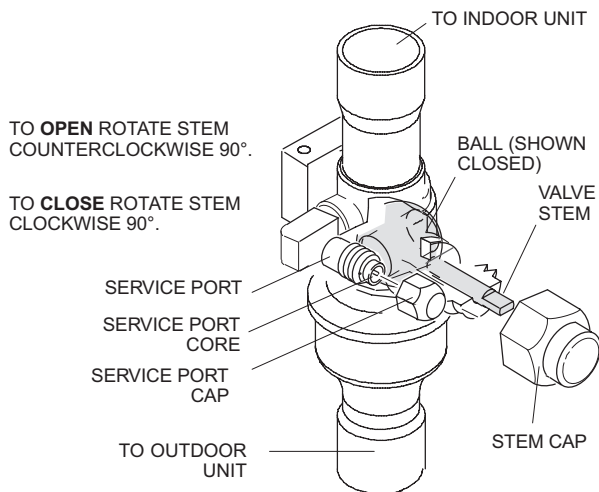
When service valve is **OPEN**, the service port is open to line set, indoor and outdoor unit.



WHEN SERVICE VALVE IS **CLOSED**, THE SERVICE PORT IS OPEN TO THE LINE SET AND INDOOR UNIT.

## Operating Ball Type Service Valve:

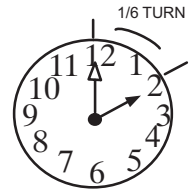
1. Remove stem cap with an appropriately sized wrench.
2. Use an appropriately sized wrench to open. To open valve, rotate stem counterclockwise 90°. To close rotate stem clockwise 90°.



## To Access Service Port:

A service port cap protects the service port core from contamination and serves as the primary leak seal.

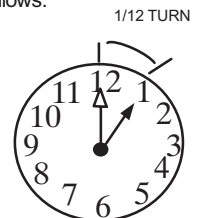
1. Remove service port cap with an appropriately sized wrench.
2. Connect gauge set to service port.
3. When testing is completed, replace service port cap and tighten as follows:
  - With torque wrench: Finger tighten and torque cap per table 3.
  - Without torque wrench: Finger tighten and use an appropriately sized wrench to turn an additional 1/6 turn clockwise.



## Reinstall Stem Cap:

Stem cap protects the valve stem from damage and serves as the primary seal. Replace the stem cap and tighten as follows:

- With Torque Wrench: Finger tighten and then torque cap per table 3.
- Without Torque Wrench: Finger tighten and use an appropriately sized wrench to turn an additional 1/12 turn clockwise.



NOTE — A label with specific torque requirements may be affixed to the stem cap. If the label is present, use the specified torque.

FIGURE 3. Angle and Ball Service Valves

## Installation

### Unit Placement

See Unit Dimensions on page 8 for sizing mounting slab, platforms or supports.

### **⚠ CAUTION**

In order to avoid injury, take proper precaution when lifting heavy objects..

### POSITIONING CONSIDERATIONS

Consider the following when positioning the unit:

- Some localities are adopting sound ordinances based on the unit's sound level registered from the adjacent property, not from the installation property. Install the unit as far as possible from the property line.
- When possible, do not install the unit directly outside a window. Glass has a very high level of sound transmission. For proper placement of unit in relation to a window see the provided illustration in figure 5, detail A.

### PLACING UNIT ON SLAB

When installing unit at grade level, the top of the slab should be high enough above grade so that water from higher ground will not collect around the unit. The slab should have a slope tolerance as described in figure 5, detail B.

**NOTE** – If necessary for stability, anchor unit to slab as described in figure 5, detail D.

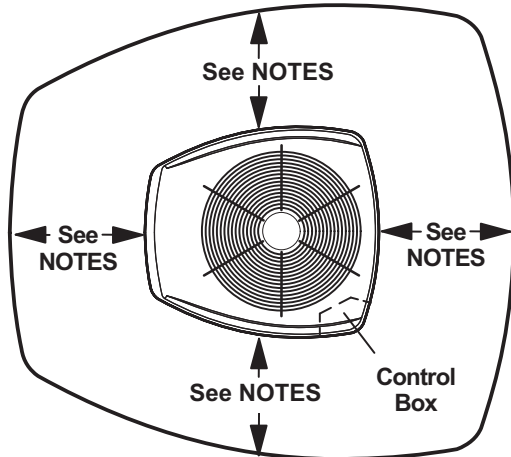
### ELEVATING THE UNIT

Units are outfitted with elongated support feet as illustrated in figure 5, detail C.

If additional elevation is necessary, raise the unit by extending the height of the unit support feet. Use a 2-inch (50.8mm) Schedule 40 female threaded adapter to raise the height of the unit.

The specified coupling will fit snugly into the recessed portion of the feet. Use additional 2-inch (50.8mm) Schedule 40 male threaded adaptors which can be threaded into the female threaded adaptors to make additional adjustments to the level of the unit.

**NOTE** – Keep the height of extenders short enough to ensure a sturdy installation. If it is necessary to extend the height further than what is stable, consider a different type of field-fabricated framework that is sturdy enough for greater heights.



### NOTES:

Service clearance of 30 in. must be maintained on one of the sides adjacent to the control box.

Clearance to one of the other three sides must be 36 in.

Clearance to one of the remaining two sides may be 12 in. and the final side may be 6 in.

A clearance of 24 in. must be maintained between two units.

48 in. clearance required on top of unit.

**NOTICE:** Specific applications may require adjustment of the listed installation clearances to provide protection for the unit from physical damage or to avoid conditions which limit operating efficiency. (Example: Clearances may have to be increased to prevent snow or ice from falling on the top of the unit. Additional clearances may also be required to prevent air recirculation when the unit is installed under a deck or in another tight space.)

FIGURE 4. Installation Clearances

## STABILIZING UNIT ON UNEVEN SURFACES

### **IMPORTANT**

Unit Stabilizer Bracket Use (field-provided):

Always use stabilizers when unit is raised above the factory height. (Elevated units could become unstable in gusty wind conditions.)

Stabilizers may be used on factory height units when mounted on unstable an uneven surface..

- 1 - Remove the louvered panel from each side to expose the unit base.
- 2 - Install the brackets as illustrated in figure 6, detail D using conventional practices.
- 3 - Replace the panels after installation is complete.

## ROOF MOUNTING

Locate the unit above a load-bearing wall or area of the roof that can adequately support the unit. Consult local codes for rooftop applications.

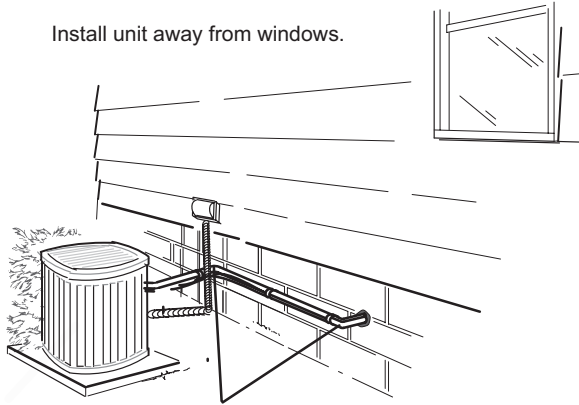
### **NOTICE**

Roof Damage!

This system contains both refrigerant and oil. Some rubber roofing material may absorb oil, causing the rubber to swell. Bubbles in the rubber roofing material can cause leaks. Protect the roof surface to avoid exposure to refrigerant and oil during service and installation. Failure to follow this notice could result in damage to roof surface.

## DETAIL A

Install unit away from windows.

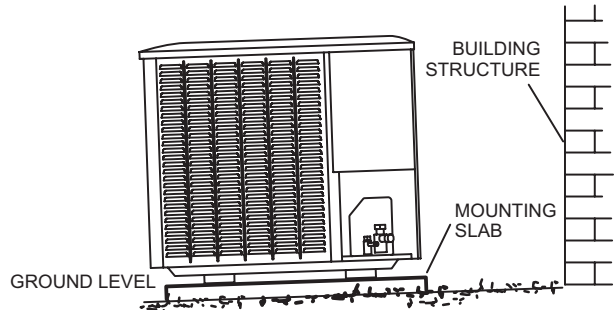


TWO 90° ELBOWS INSTALLED IN LINE SET WILL REDUCE LINE SET VIBRATION.

### Outside Unit Placement

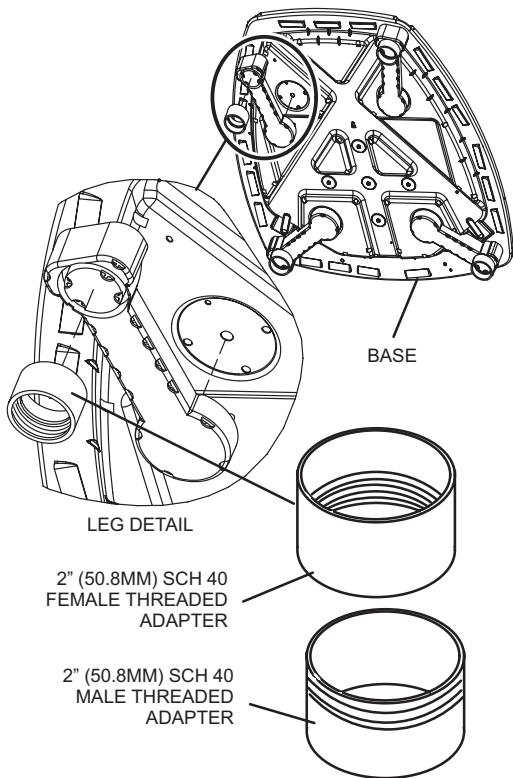
## DETAIL B

INSTALL UNIT LEVEL OR, IF ON A SLOPE, MAINTAIN SLOPE TOLERANCE OF 2 DEGREES (OR 2 INCHES PER 5 FEET [50 MM PER 1.5 M]) AWAY FROM BUILDING STRUCTURE.



### Slab Mounting at Ground Level

## DETAIL C



USE ADDITIONAL 2" SCH 40 MALE THREADED ADAPTERS WHICH CAN BE THREADED INTO THE FEMALE THREADED ADAPTERS TO MAKE ADDITIONAL ADJUSTMENTS TO THE LEVEL OF THE UNIT.

### Elevated Slab Mounting using Feet Extenders

## DETAIL D

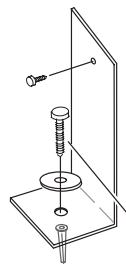
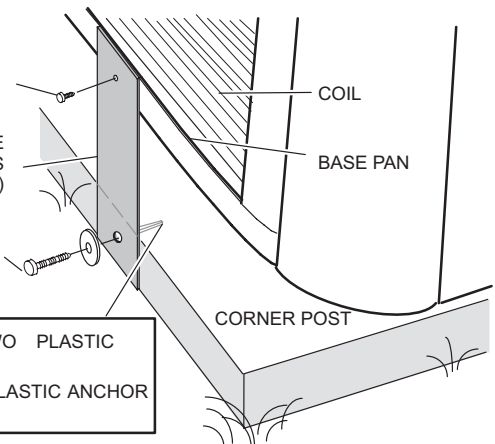
### Slab Side Mounting

#10 1/2" LONG SELF-DRILLING SHEET METAL SCREWS

STABILIZING BRACKET (18 GAUGE METAL — 2" WIDTH; HEIGHT AS REQUIRED)

#10 1-1/4" LONG HEX HEAD SCREW AND FLAT WASHER

**CONCRETE SLAB** — USE TWO PLASTIC ANCHORS (HOLE DRILL 1/4")  
**WOOD OR PLASTIC SLAB** — NO PLASTIC ANCHOR (HOLE DRILL 1/8")



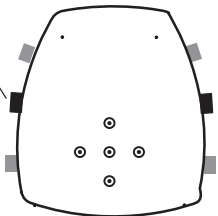
### Deck Top Mounting

STABILIZING BRACKET (18 GAUGE METAL — 2" (50.8MM) WIDTH; HEIGHT AS REQUIRED); BEND TO FORM RIGHT ANGLE

SAME FASTENERS AS SLAB SIDE MOUNTING.

MINIMUM ONE PER SIDE

FOR EXTRA STABILITY



ONE BRACKET PER SIDE (MIN.); FOR EXTRA STABILITY, TWO BRACKETS PER SIDE, 2" (50.8MM) FROM EACH CORNER.

### Stabilizing Unit on Uneven Surfaces

**IMPORTANT** - To help stabilize an outdoor unit, some installations may require strapping the unit to the pad using brackets and anchors commonly available in the marketplace.

FIGURE 5. Placement and Slab Mounting

## Removing and Installing Panels

### LOUVERED PANEL REMOVAL

Remove the louvered panels as follows:

1. Remove two screws, allowing the panel to swing open slightly.
2. Hold the panel firmly throughout this procedure. Rotate bottom corner of panel away from hinged corner post until lower three tabs clear the slots as illustrated in **Detail B**.
3. Move panel down until lip of upper tab clears the top slot in corner post as illustrated in **Detail A**.

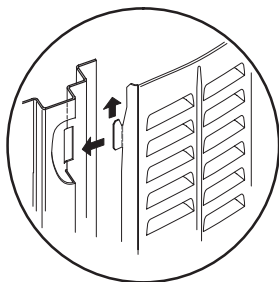
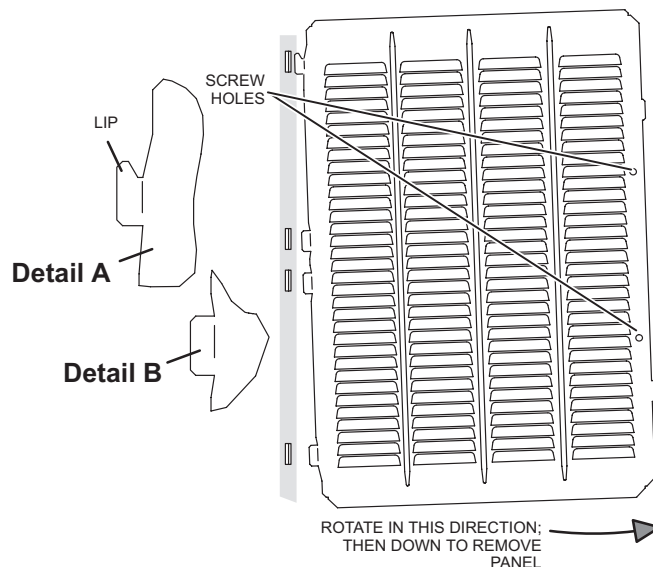
### LOUVERED PANEL INSTALLATION

Position the panel almost parallel with the unit as illustrated in **Detail D** with the screw side as close to the unit as possible. Then, in a continuous motion:

1. Slightly rotate and guide the lip of the top tab inward as illustrated in **Detail A** and **C**; then upward into the top slot of the hinge corner post.
2. Rotate the panel until it is completely vertical to fully engage all of the tabs.
3. Holding the panel's hinged side firmly in place, close the right-hand side of the panel, aligning the screw holes.
4. When panel is correctly positioned and aligned, insert the screws and tighten.

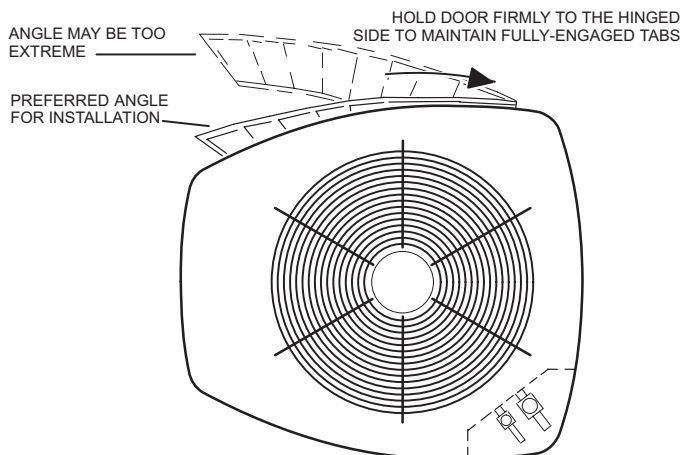
**IMPORTANT!** DO NOT ALLOW PANELS TO HANG ON UNIT BY TOP TAB. TAB IS FOR ALIGNMENT AND NOT DESIGNED TO SUPPORT WEIGHT OF PANEL.

PANEL SHOWN SLIGHTLY ROTATED TO ALLOW TOP TAB TO EXIT (OR ENTER) TOP SLOT FOR REMOVING (OR INSTALLING) PANEL.



**Detail C**

MAINTAIN MINIMUM PANEL ANGLE (AS CLOSE TO PARALLEL WITH THE UNIT AS POSSIBLE) WHILE INSTALLING PANEL.



**FIGURE 6. Removing and Installing Panels**



## New or Replacement Line Set

### **⚠ IMPORTANT**

If this unit is being matched with an approved line set or indoor unit coil that was previously charged with mineral oil, or if it is being matched with a coil which was manufactured before January of 1999, the coil and line set must be flushed prior to installation. Take care to empty all existing traps. Polyvinyl ether (PVE) and polyol ester (POE) oils are used in Lennox variable-capacity units charged with R454B refrigerant. Residual mineral oil can act as an insulator, preventing proper heat transfer. It can also clog the expansion device and reduce system performance and capacity. Failure to properly flush the system per this instruction and the detailed Installation and Service Procedures manual will void the warranty.

Flush the existing line set per the following instructions. For more information, refer to the Installation and Service Procedures manual available on LennoxPros.com. CAUTION - DO NOT attempt to flush and re-use existing line sets or indoor coil when the system contains contaminants (i.e., compressor burn out).

Polyvinyl ether (PVE) oil is used in the EL19KPV units.

If a new line set is being installed, size the piping per table 2.

**TABLE 2**

REFRIGERANT LINE SET – INCHES (MM)					
Model	Valve Field Connections		Recommended Line Set		
	Liquid Line	Vapor Line	Liquid Line	Vapor Line	L15 Line Sets
-024	3/8 in. (10 mm)	3/4 in. (19 mm)	3/8 in. (10 mm)	3/4 in. (19 mm)	L15-41 15 ft. - 50 ft. (4.6 m - 15 m)
-036	3/8 in. (10 mm)	7/8 in. (22 mm)	3/8 in. (10 mm)	7/8 in. (22 mm)	L15-65 15 ft. - 50 ft. (4.6 m - 15 m)
-048					
-060	3/8 in. (10 mm)	1-1/8 in. (28 mm)	3/8 in. (10 mm)	1-1/8 in. (28 mm)	Field Fabricated

NOTE - Some applications may require a field-provided 7/8" to 1-1/8" adapter.

**NOTE** - When installing refrigerant lines longer than 50 feet, refer to the Refrigerant Piping Design and Fabrication Guidelines manual available on LennoxPros.com (Corp. 9351-L9), or contact the Technical Support Department Product Application group for assistance.

### Line Set Joints - Furnace Application

Evaporator primary line set joints in all applications shall have a line set joint sleeve.

Evaporator primary line sets should not have additional joints not covered by line set joint sleeve.

If additional joints are present, the system installation shall comply with one of the options below:

**Option 1** - Furnace is installed as a direct vent appliance;

**Option 2** - Furnace/Evaporator installation is in a space greater than the minimum conditioned area (Amin);

**Option 3** - Furnace/Evaporator installation is connected to a space greater than the minimum conditioned area (Amin) through an opening of at least 15 in<sup>2</sup> (4-inch diameter hole equivalent) located below the level of the furnace burners;

**Option 4** - Have a second refrigerant detection sensor installed below the level of the burners (see Secondary Sensor Installation section).

### Multiple Systems Installed in Same Space

For any A2L refrigerant system with additional joints not covered by line set joint sleeves, each system in the same space must have refrigerant detection sensor installed below the level of the burners (see Secondary Sensor Installation section). If all the systems in the same space are installed with direct vent application, then additional refrigerant detection sensor is not needed

### Secondary Sensor Installation

If secondary refrigerant sensor is required, it shall be mounted as follows:

**Upflow Applications:** Mounted on an unused side furnace return air connection at least 9 inches above the floor and within 9 inches from front of furnace.

**Downflow Applications:** Mounted on one side of the evaporator coil 9 inches above the floor and within 9 inches from front of coil.

**Horizontal Applications:** Mounted on the bottom side return furnace air connection within 9 inches of both the blower deck and front of furnace.

Connect the refrigerant sensor to the second sensor input on the RDS Control. Refer to the instructions provided with the sensor or the RDS controller to enable the second sensor.

### **⚠ WARNING**



When using a high pressure gas such as nitrogen to pressurize a refrigeration or air conditioning system, use a regulator that can control the pressure down to 1 or 2 psig (6.9 to 13.8 kPa).

## WARNING

Refrigerant can be harmful if it is inhaled. Refrigerant must be used and recovered responsibly. Failure to follow this warning may result in personal injury or death.

## WARNING



Fire, Explosion and Personal Safety hazard. Failure to follow this warning could result in damage, personal injury or death. Never use oxygen to pressurize or purge refrigeration lines. Oxygen, when exposed to a spark or open flame, can cause fire and/or an explosion, that could result in property damage, personal injury or death.

## WARNING

Polyvinyl ether (PVE) oils used with R454B refrigerant absorb moisture very quickly. It is very important that the refrigerant system be kept closed as much as possible. **DO NOT** remove line set caps or service valve stub caps until you are ready to make connections.

The EL19KPV is a variable-capacity cooling system utilizing variable speed compressor technology. With the variable speed compressor and variable pumping capacity, additional consideration must be given to refrigerant piping sizing and application. The guidelines below are to be used exclusively for the EL19KPV systems.

### COOLING SYSTEM (R454B)

- Total equivalent length equals 180 feet (piping and all fittings included).

**NOTE** – Length is general guide. Lengths may be more or less, depending on remaining system design factors.

- Maximum linear (actual) length = 150 feet.
- Maximum linear liquid lift = 60 feet.

**NOTE** – Maximum lifts are dependent on total length, number of elbows, etc. that contribute to total pressure drop.

- Maximum length vapor riser = 60 feet.
- **Up to 50 Linear Feet:** Use rated line sizes listed in table 3.
- **Between 51 and 150 Linear Feet:** Crankcase heater and nonbleed port TXV factory installed. No additional components required. Vertical vapor riser must be sized to the vapor riser listed in the table 4 on systems with line sets longer than 51 feet. Use tables 3 and 4 to determine the correct liquid and vapor line sizes.
- **Over 150 Linear Feet:** not recommended.
- Additional oil is not required for systems with line lengths up to 150 feet.

### SUCTION TRAPS

For systems with the outdoor unit 5 - 60 feet above the indoor unit, one trap must be installed at the bottom of the suction riser.

**TABLE 3. Standard Refrigerant Line Set – Up to 50 Linear Feet in Length**

Inches (mm)					
EL19KPV*	Valve Size Connections		Recommended Line Sets		
	Liquid Line	Suction Line	L15 Line Set Model	Line Set Length	Catalog Number
-024	3/8" (10 mm)	3/4" (19 mm)	L15-41-30	30 feet (9.1 m)	89J60
-036 -048	3/8" (10 mm)	7/8" (22 mm)	L15-65-40	40 feet (12.2 m)	89J61
			L15-65-50	50 feet (15.2 m)	89J62
-060	3/8" (10 mm)	1-1/8" (29 mm) **	Field-fabricated		

\* Applicable to all minor revision numbers unless otherwise specified.

\*\* Some applications may require a field-provided 1-1/8" to 7/8" adapter.

**TABLE 4. EL19KPV Line Set Guidelines – 51 to 150 Linear Feet in Length**

Model	Maximum Total Equivalent Length (ft)	Maximum Linear (actual) Length (ft)	Maximum Vapor Riser (ft)	Maximum Linear Liquid Lift (ft)	Preferred Vapor Line Sizes for Horizontal Runs	Required Vapor Riser Size
-024	180	150	60	60	7/8"	5/8"
-036	180	150	60	60	7/8"	3/4"
-048	180	150	60	60	7/8"	7/8"
-060	180	150	60	60	7/8"	7/8"

**TABLE 5. Liquid Line Diameter Selection Table**

Unit	Line Size	Total Linear Length (feet)						Max. Elevation (ft)
		25	50	75	100	125	150	
-024	5/16"	25	50	55	48	40	33	
	3/8"	25	50	60	60	60	60	
-036	3/8"	25	50	60	56	51	45	
	1/2"	25	50	60	60	60	60	
-048	3/8"	25	50	50	41	31	22	
	1/2"	25	50	60	60	60	60	
-060	3/8"	25	50	36	22	8	NR	
	1/2"	25	50	60	60	60	59	

**NOTE** - Shaded rows indicate rated liquid line size

- Find your unit on the left side of the table.
- Start with the rated liquid line size (shaded row) on the outdoor unit
- Select the actual Total Linear Length of your system shown at the top of the table.
- The elevation listed in the table is the maximum allowed for the liquid line listed.
- Select or consider the larger liquid line size shown in the table if the elevation does not meet your requirements.

**NOTE** - For new or replacement line set installation, refer to Service and Application Note - Corp. 9112-L4 (C-91-4).

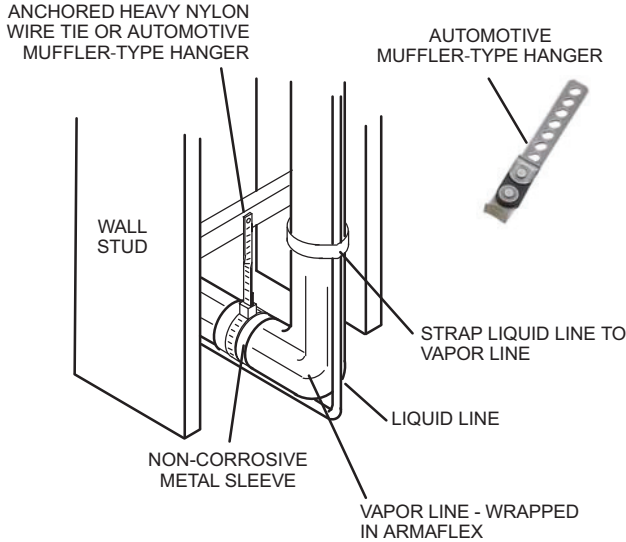
# LINE SET

**IMPORTANT** — Refrigerant lines must not contact structure.

## INSTALLATION

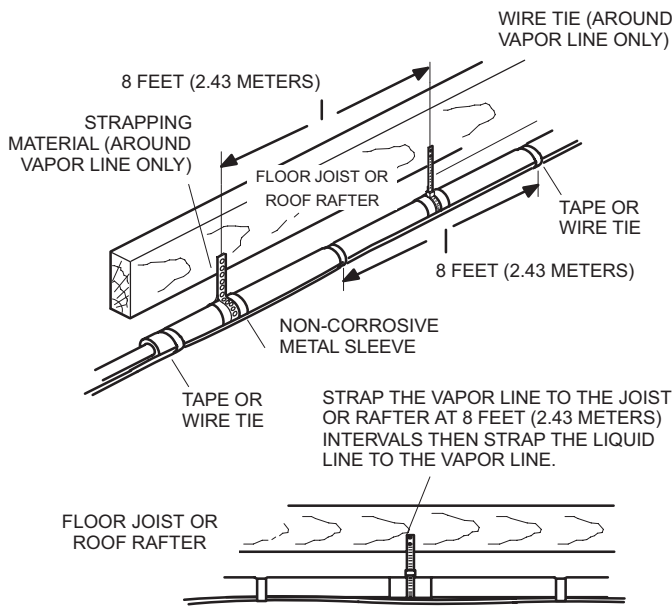
**Line Set Isolation** — The following illustrations are examples of proper refrigerant line set isolation:

### REFRIGERANT LINE SET — TRANSITION FROM VERTICAL TO HORIZONTAL



### REFRIGERANT LINE SET — INSTALLING HORIZONTAL RUNS

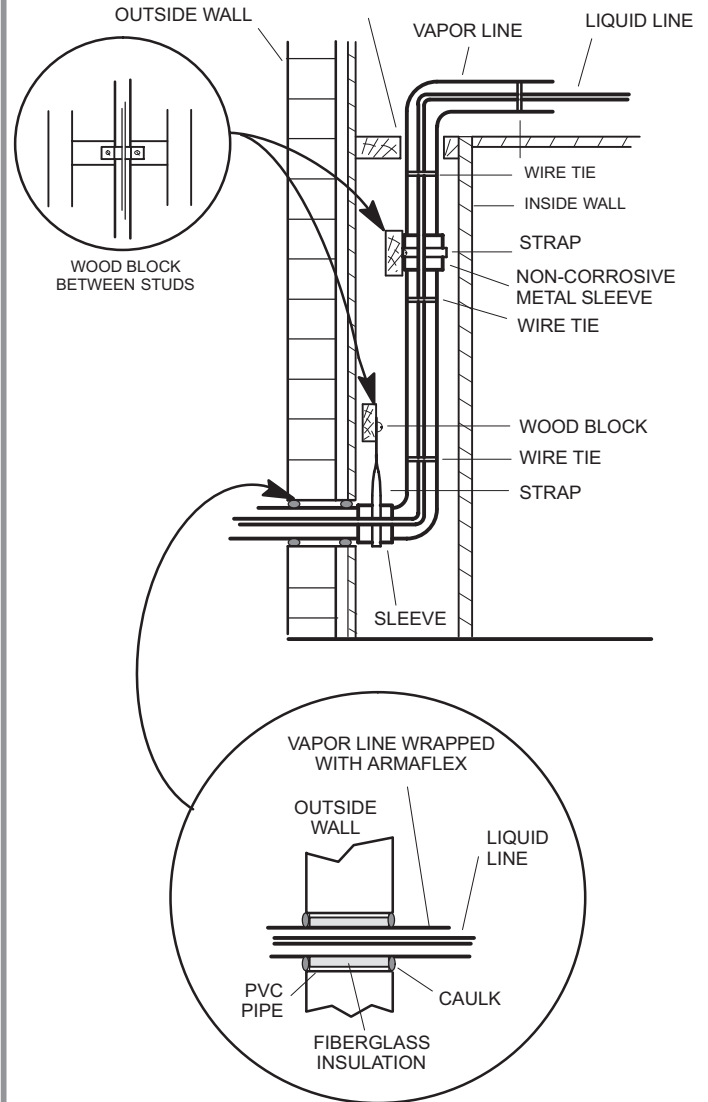
To hang line set from joist or rafter, use either metal strapping material or anchored heavy nylon wire ties.



### REFRIGERANT LINE SET — INSTALLING VERTICAL RUNS (NEW CONSTRUCTION SHOWN)

**NOTE** — Insulate liquid line when it is routed through areas where the surrounding ambient temperature could become higher than the temperature of the liquid line or when pressure drop is equal to or greater than 20 psig.

**IMPORTANT** — Refrigerant lines must not contact wall



**NOTE** — Similar installation practices should be used if line set is to be installed on exterior of outside wall.

**WARNING** — Polyol ester (POE) oils used with HFC-410A refrigerant absorb moisture very quickly. It is very important that the refrigerant system be kept closed as much as possible. **DO NOT** remove line set caps or service valve stub caps until you are ready to make connections.

FIGURE 7. Line Set Installation

## Brazing Connections

Use the procedures outlined in figures 8 and 9 for brazing line set connections to service valves.

### WARNING



Danger of fire. Bleeding the refrigerant charge from only the high side may result in pressurization of the low side shell and suction tubing. Application of a brazing torch to a pressurized system may result in ignition of the refrigerant and oil mixture. Check the high and low pressures before applying heat.

### WARNING



When using a high pressure gas such as nitrogen to pressurize a refrigeration or air conditioning system, use a regulator that can control the pressure down to 1 or 2 psig (6.9 to 13.8 kPa).

### CAUTION

Brazing alloys and flux contain materials which are hazardous to your health.

Avoid breathing vapors or fumes from brazing operations. Perform operations only in well-ventilated areas.

Wear gloves and protective goggles or face shield to protect against burns.

Wash hands with soap and water after handling brazing alloys and flux.

### IMPORTANT

Allow braze joint to cool before removing the wet rag from the service valve. Temperatures above 250°F can damage valve seals.

### IMPORTANT

Use silver alloy brazing rods with 5% minimum silver alloy for copper-to-copper brazing. Use 45% minimum alloy for copper-to-brass and copper-to-steel brazing.

### WARNING

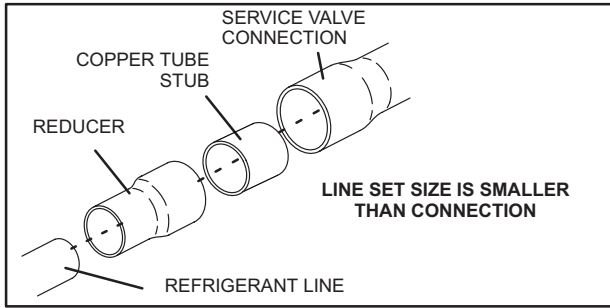
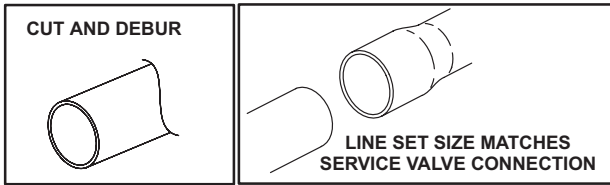


Fire, Explosion and Personal Safety hazard. Failure to follow this warning could result in damage, personal injury or death.

Never use oxygen to pressurize or purge refrigeration lines. Oxygen, when exposed to a spark or open flame, can cause fire and/or an explosion, that could result in property damage, personal injury or death.

# 1 PIPING PANEL REMOVAL AND LINE SET PREPARATION

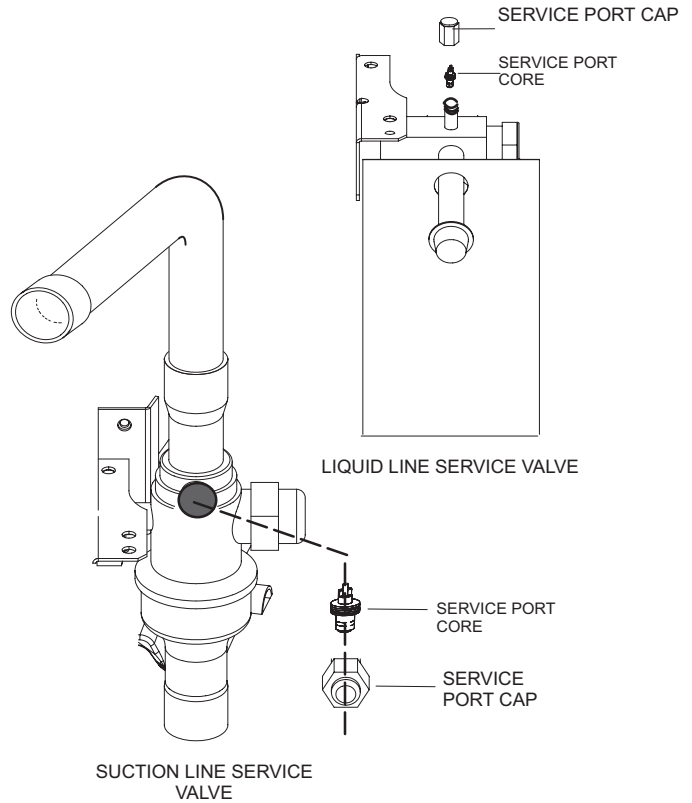
Remove piping panel for easier access to service valves. Cut ends of the refrigerant lines square (free from nicks or dents) and debur the ends. The pipe must remain round. Do not crimp end of the line.



DO NOT CRIMP SERVICE VALVE CONNECTOR WHEN PIPE IS SMALLER THAN CONNECTION

# 2 CAP AND CORE REMOVAL

Remove service cap and core from both the suction and liquid line service ports.



# 3 ATTACH THE MANIFOLD GAUGE SET FOR BRAZING LIQUID AND SUCTION LINE SERVICE VALVES

- A. Connect gauge set low pressure side to liquid line service valve (service port).
- B. Connect gauge set center port to bottle of nitrogen with regulator.
- C. With valve core removed from the suction line service port, nitrogen flow will have an exit point.

SUCTION SERVICE PORT MUST BE OPEN AND SERVICE PORT CORE REMOVED TO ALLOW EXIT POINT FOR NITROGEN FLOW

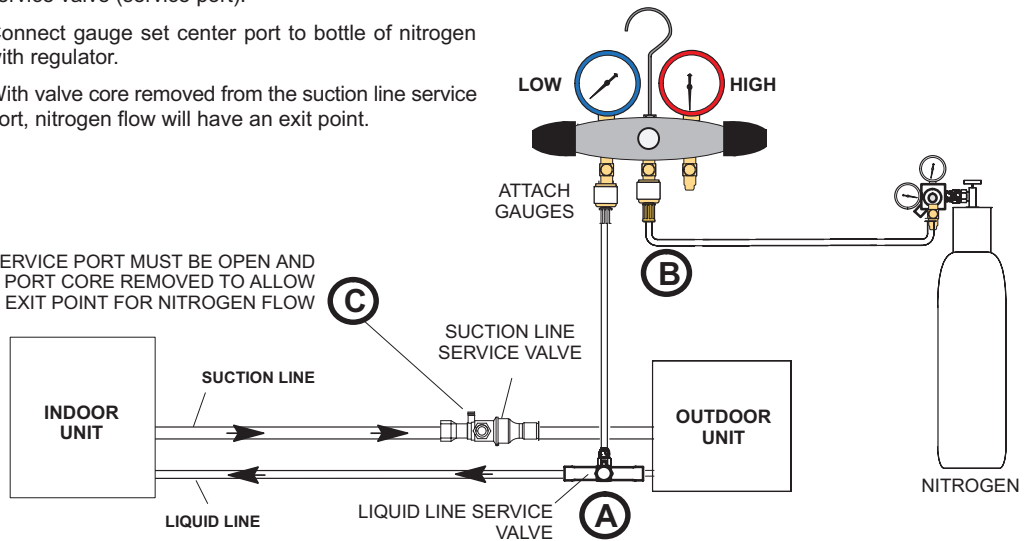


FIGURE 8. Brazing Procedures

## 4 WRAP SERVICE VALVES

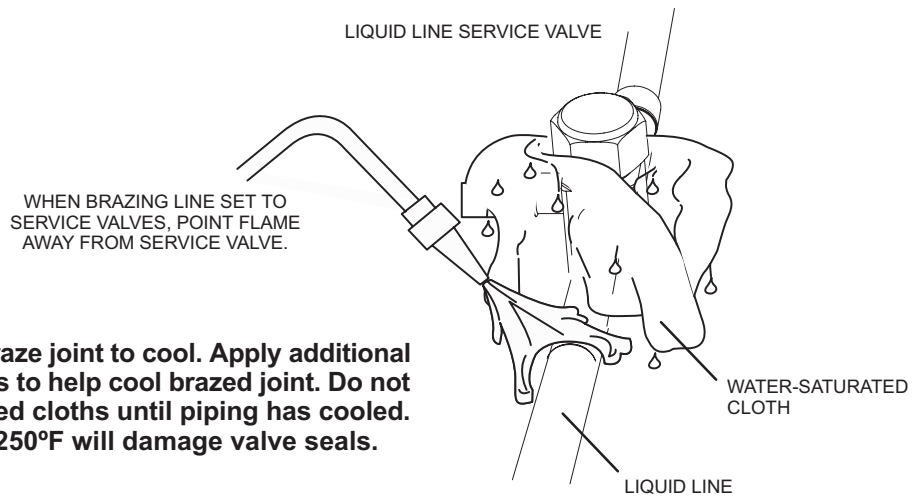
To help protect service valve seals during brazing, wrap water-saturated cloths around service valve bodies and copper tube stubs. Use additional water-saturated cloths underneath the valve body to protect the base paint.

## 5 FLOW NITROGEN

Flow regulated nitrogen (at 1 to 2 psig) through the refrigeration gauge set into the valve stem port connection on the liquid service valve and out of the suction / vapor valve stem port. See steps 3A, 3B and 3C on manifold gauge set connections.

## 6 BRAZE LINE SET

Wrap both service valves with water-saturated cloths as illustrated here and as mentioned in step 4, before brazing to line set. Cloths must remain water-saturated throughout the brazing and cool-down process.

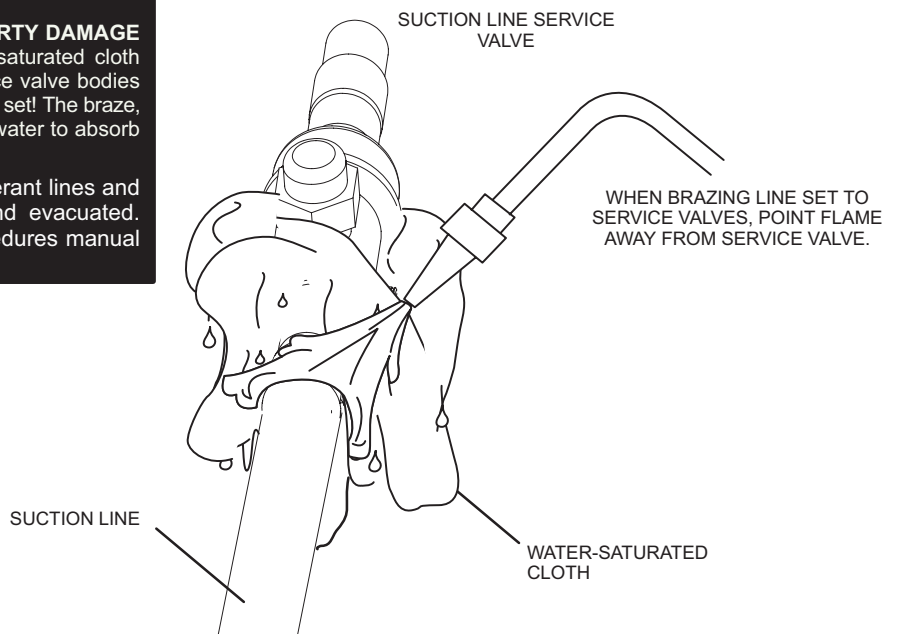


**IMPORTANT - Allow braze joint to cool. Apply additional water-saturated cloths to help cool brazed joint. Do not remove water-saturated cloths until piping has cooled. Temperatures above 250°F will damage valve seals.**

### WARNING

**FIRE, PERSONAL INJURY, OR PROPERTY DAMAGE** may result if you do not wrap a water-saturated cloth around both liquid and suction line service valve bodies and copper tube stub while brazing the line set! The braze, when complete, must be quenched with water to absorb any residual heat.

Do not open service valves until refrigerant lines and indoor coil have been leak-tested and evacuated. Refer to Installation and Service Procedures manual found on [LennoxPros.com](http://LennoxPros.com).



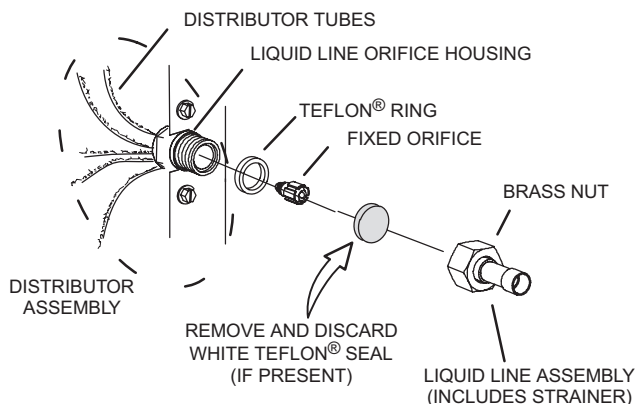
## 7 PREPARATION FOR NEXT STEP

Disconnect manifold gauge set from service ports after all connections have been brazed. Apply additional water-saturated cloths to both service valves to cool piping. Once piping is cool, remove all water-saturated cloths.

**FIGURE 9. Brazing Procedures (Cont'd)**

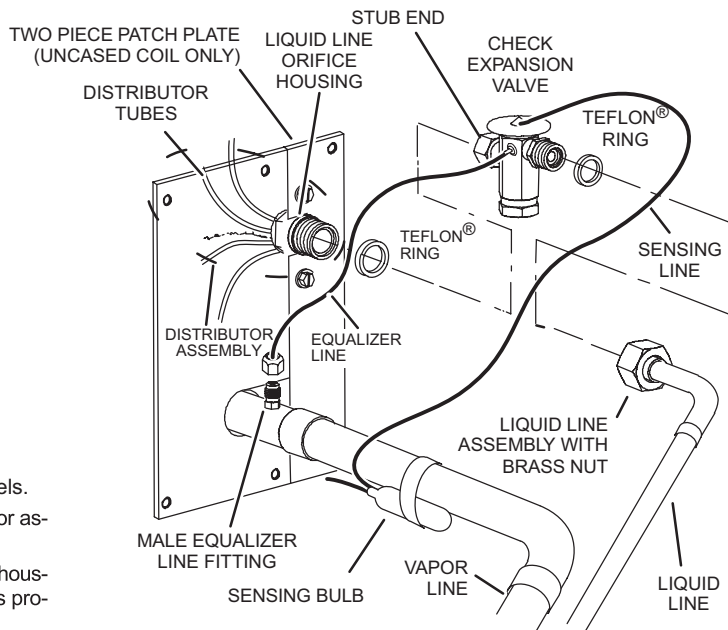
## Flushing Line Set and Indoor Coil

### 1A TYPICAL EXISTING FIXED ORIFICE REMOVAL PROCEDURE (UNCASED OR COIL SHOWN)



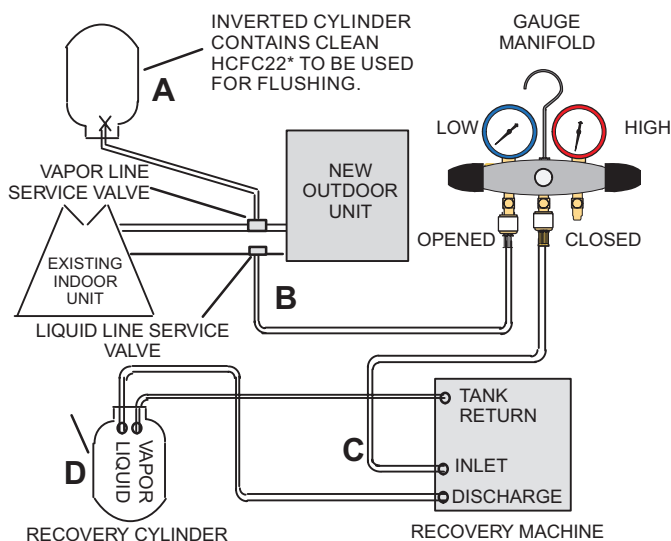
- A On fully cased coils, remove the coil access and plumbing panels.
- B Remove any shipping clamps holding the liquid line and distributor assembly.
- C Using two wrenches, disconnect liquid line from liquid line orifice housing. Take care not to twist or damage distributor tubes during this process.
- D Remove and discard fixed orifice, valve stem assembly if present and Teflon® washer as illustrated above.
- E Use a field-provided fitting to temporarily reconnect the liquid line to the indoor unit's liquid line orifice housing.

### 1B TYPICAL EXISTING EXPANSION VALVE REMOVAL PROCEDURE (UNCASED COIL SHOWN)



- A On fully cased coils, remove the coil access and plumbing panels.
- B Remove any shipping clamps holding the liquid line and distributor assembly.
- C Disconnect the equalizer line from the check expansion valve equalizer line fitting on the vapor line.
- D Remove the vapor line sensing bulb.
- E Disconnect the liquid line from the check expansion valve at the liquid line assembly.
- F Disconnect the check expansion valve from the liquid line orifice housing. Take care not to twist or damage distributor tubes during this process.
- G Remove and discard check expansion valve and the two Teflon® rings.
- H Use a field-provided fitting to temporary reconnect the liquid line to the indoor unit's liquid line orifice housing.

### 2 CONNECT GAUGES AND EQUIPMENT FOR FLUSHING PROCEDURE



- A Inverted HCFC-22 cylinder with clean refrigerant\* to the vapor service valve.
- B HCFC-22 gauge set (low side) to the liquid line valve.
- C HCFC-22 gauge set center port to inlet on the recovery machine with an empty recovery tank to the gauge set.
- D Connect recovery tank to recovery machines per machine instructions.

**\*IMPORTANT - Clean refrigerant is any refrigerant in a system that has not had compressor burn out. If the system has experienced burn out, it is recommended that the existing line set and indoor coil be replaced.**

### 3 FLUSHING LINE SET

The line set and indoor unit coil must be flushed with at least the same amount of clean refrigerant\* that previously charged the system. Check the charge in the flushing cylinder before proceeding.

- A Set the recovery machine for liquid recovery and start the recovery machine. Open the gauge set valves to allow the recovery machine to pull a vacuum on the existing system line set and indoor unit coil.
- B Invert the cylinder of clean HCFC-22\* and open its valve to allow liquid refrigerant to flow into the system through the vapor line valve. Allow the refrigerant to pass from the cylinder and through the line set and the indoor unit coil before it enters the recovery machine.
- C After all of the liquid refrigerant has been recovered, switch the recovery machine to vapor recovery so that all of the HCFC-22 vapor is recovered. Allow the recovery machine to pull the system down to 0.
- D Close the valve on the inverted HCFC-22 drum and the gauge set valves. Pump the remaining refrigerant out of the recovery machine and turn the machine off.

FIGURE 10. Removing Metering Device and Flushing

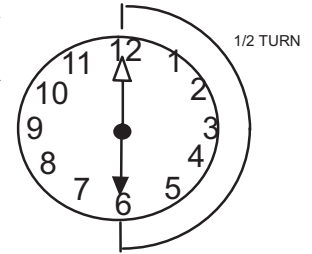
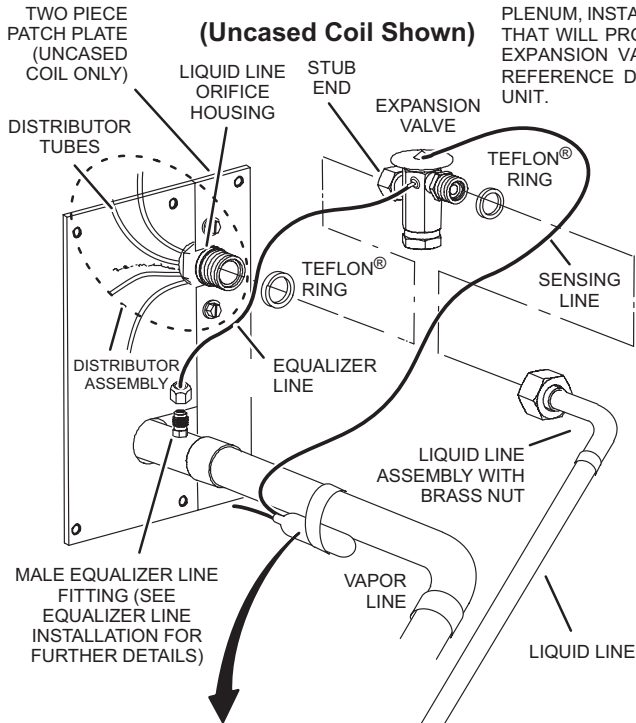


## FLUSHING LINE SET AND INDOOR COIL (2 OF 2)

### 4 TYPICAL NEW CHECK EXPANSION VALVE INSTALLATION PROCEDURE

THIS OUTDOOR UNIT IS DESIGNED FOR USE IN SYSTEMS THAT USE A CHECK EXPANSION VALVE METERING DEVICE. SEE THE UNIT PRODUCT SPECIFICATIONS FOR APPROVED EXPANSION VALVE KIT MATCH-UPS AND APPLICATION INFORMATION.

THE EXPANSION VALVE UNIT CAN BE INSTALLED INTERNAL OR EXTERNAL TO THE INDOOR COIL. IN APPLICATIONS WHERE AN UNCASSED COIL IS BEING INSTALLED IN A FIELD-PROVIDED PLENUM, INSTALL THE CHECK EXPANSION VALVE IN A MANNER THAT WILL PROVIDE ACCESS FOR FIELD SERVICING OF THE EXPANSION VALVE. REFER TO BELOW ILLUSTRATION FOR REFERENCE DURING INSTALLATION OF EXPANSION VALVE UNIT.



- REMOVE THE FIELD-PROVIDED FITTING THAT TEMPORARILY RECONNECTED THE LIQUID LINE TO THE INDOOR UNIT'S DISTRIBUTOR ASSEMBLY.
- INSTALL ONE OF THE PROVIDED TEFLON® RINGS AROUND THE STUBBED END OF THE EXPANSION VALVE AND LIGHTLY LUBRICATE THE CONNECTOR THREADS AND EXPOSE SURFACE OF THE TEFLON® RING WITH REFRIGERANT OIL.
- ATTACH THE STUBBED END OF THE EXPANSION VALVE TO THE LIQUID LINE ORIFICE HOUSING. FINGER TIGHTEN AND USE AN APPROPRIATELY SIZED WRENCH TO TURN AN ADDITIONAL 1/2 TURN CLOCKWISE AS ILLUSTRATED IN THE FIGURE ABOVE, OR 20 FT-LB.
- PLACE THE REMAINING TEFLON® WASHER AROUND THE OTHER END OF THE EXPANSION VALVE. LIGHTLY LUBRICATE CONNECTOR THREADS AND EXPOSE SURFACE OF THE TEFLON® RING WITH REFRIGERANT OIL.
- ATTACH THE LIQUID LINE ASSEMBLY TO THE EXPANSION VALVE. FINGER TIGHTEN AND USE AN APPROPRIATELY SIZED WRENCH TO TURN AN ADDITIONAL 1/2 TURN CLOCKWISE AS ILLUSTRATED IN THE FIGURE ABOVE OR 20 FT-LB.

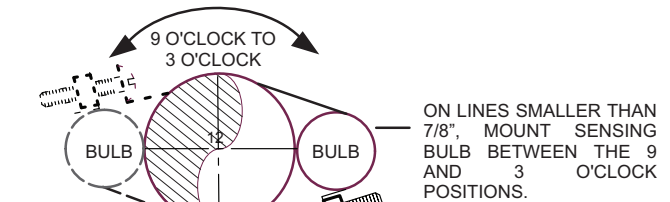
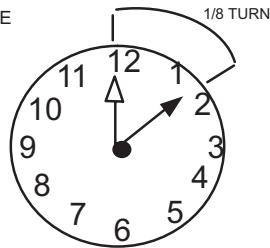
SENSING BULB INSULATION IS REQUIRED IF MOUNTED EXTERNAL TO THE COIL CASING. SEE SENSING BULB INSTALLATION FOR BULB POSITIONING.

### SENSING BULB INSTALLATION

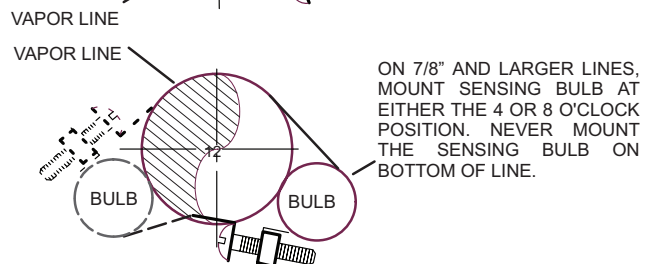
- ATTACH THE VAPOR LINE SENSING BULB IN THE PROPER ORIENTATION AS ILLUSTRATED TO THE RIGHT USING THE CLAMP AND SCREWS PROVIDED.

**NOTE - CONFIRM PROPER THERMAL CONTACT BETWEEN VAPOR LINE AND CHECK EXPANSION BULB BEFORE INSULATING THE SENSING BULB ONCE INSTALLED.**

- CONNECT THE EQUALIZER LINE FROM THE EXPANSION VALVE TO THE EQUALIZER VAPOR PORT ON THE VAPOR LINE. FINGER TIGHTEN THE FLARE NUT PLUS 1/8 TURN (7 FT-LBS) AS ILLUSTRATED BELOW.



ON LINES SMALLER THAN 7/8", MOUNT SENSING BULB BETWEEN THE 9 AND 3 O'CLOCK POSITIONS.

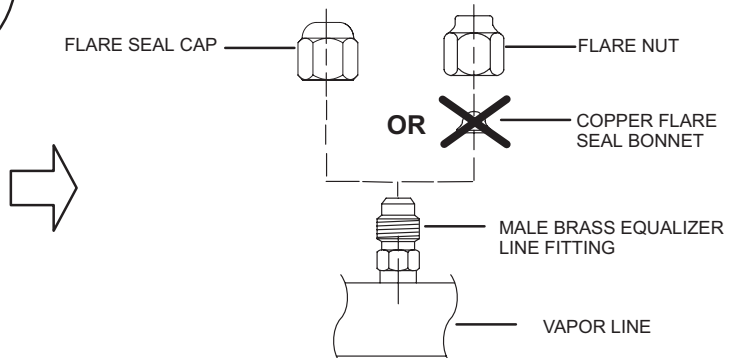


ON 7/8" AND LARGER LINES, MOUNT SENSING BULB AT EITHER THE 4 OR 8 O'CLOCK POSITION. NEVER MOUNT THE SENSING BULB ON BOTTOM OF LINE.

**NOTE - NEVER MOUNT THE SENSING BULB ON BOTTOM OF LINE.**

### EQUALIZER LINE INSTALLATION

REMOVE AND DISCARD EITHER THE FLARE SEAL CAP OR FLARE NUT WITH COPPER FLARE SEAL BONNET FROM THE EQUALIZER LINE PORT ON THE VAPOR LINE AS ILLUSTRATED IN THE FIGURE TO THE RIGHT.



**⚠ IMPORTANT**

The Environmental Protection Agency (EPA) prohibits the intentional venting of A2L refrigerants during maintenance, service, repair and disposal of appliance. Approved methods of recovery, recycling or reclaiming must be followed.

**⚠ IMPORTANT**

If this unit is being matched with an approved line set or indoor unit coil that was previously charged with mineral oil, or if it is being matched with a coil which was manufactured before January of 1999, the coil and line set must be flushed prior to installation. Take care to empty all existing traps. Polyvinyl ether (PVE) oils are used in Lennox variable-capacity units charged with R454B refrigerant. Residual mineral oil can act as an insulator, preventing proper heat transfer. It can also clog the expansion device and reduce system performance and capacity. Failure to properly flush the system per this instruction and the detailed Installation and Service Procedures manual will void the warranty.

**Leak Testing the System**

**⚠ WARNING**



When using a high pressure gas such as nitrogen to pressurize a refrigeration or air conditioning system, use a regulator that can control the pressure down to 1 or 2 psig (6.9 to 13.8 kPa).

**⚠ IMPORTANT**

Leak detector must be capable of sensing A2L refrigerant.

**⚠ WARNING**

Refrigerant can be harmful if it is inhaled. Refrigerant must be used and recovered responsibly.

Failure to follow this warning may result in personal injury or death.

# LEAK TEST

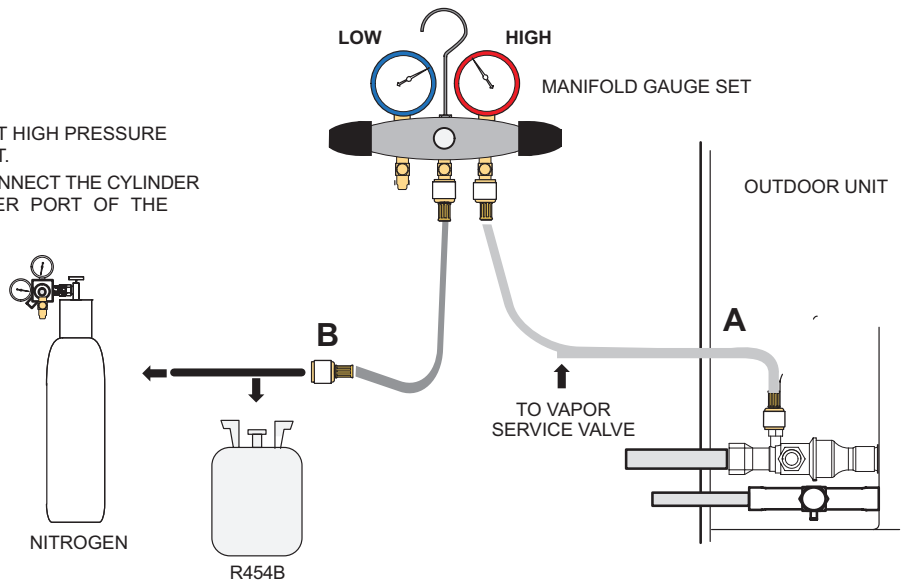
## LINE SET AND INDOOR COIL

**NOTE - NORMALLY, THE HIGH PRESSURE HOSE IS CONNECTED TO THE LIQUID LINE PORT. HOWEVER, CONNECTING IT TO THE VAPOR PORT BETTER PROTECTS THE MANIFOLD GAUGE SET FROM HIGH PRESSURE DAMAGE.**

### 1 CONNECT GAUGE SET

- A. CONNECT AN R454B MANIFOLD GAUGE SET HIGH PRESSURE HOSE TO THE VAPOR VALVE SERVICE PORT.
- B. WITH BOTH MANIFOLD VALVES CLOSED, CONNECT THE CYLINDER OF R454B REFRIGERANT TO THE CENTER PORT OF THE MANIFOLD GAUGE SET.

*NOTE - LATER IN THE PROCEDURE, THE R454B CONTAINER WILL BE REPLACED BY THE NITROGEN CONTAINER.*



### 2 TEST FOR LEAKS

AFTER THE LINE SET HAS BEEN CONNECTED TO THE INDOOR AND OUTDOOR UNITS, CHECK THE LINE SET CONNECTIONS AND INDOOR UNIT FOR LEAKS. USE THE FOLLOWING PROCEDURE TO TEST FOR LEAKS:

- A. WITH BOTH MANIFOLD VALVES CLOSED, CONNECT THE CYLINDER OF R454B REFRIGERANT TO THE CENTER PORT OF THE MANIFOLD GAUGE SET. OPEN THE VALVE ON THE R454B CYLINDER (VAPOR ONLY).
- B. OPEN THE HIGH PRESSURE SIDE OF THE MANIFOLD TO ALLOW R454B INTO THE LINE SET AND INDOOR UNIT. WEIGH IN A TRACE AMOUNT OF R454B. [A TRACE AMOUNT IS A MAXIMUM OF TWO OUNCES (57 G) REFRIGERANT OR THREE POUNDS (31 KPA) PRESSURE]. CLOSE THE VALVE ON THE R454B CYLINDER AND THE VALVE ON THE HIGH PRESSURE SIDE OF THE MANIFOLD GAUGE SET. DISCONNECT THE R454B CYLINDER.
- C. CONNECT A CYLINDER OF DRY NITROGEN WITH A PRESSURE REGULATING VALVE TO THE CENTER PORT OF THE MANIFOLD GAUGE SET.
- D. ADJUST DRY NITROGEN PRESSURE TO 160 PSIG (1103 KPA). OPEN THE VALVE ON THE HIGH SIDE OF THE MANIFOLD GAUGE SET IN ORDER TO PRESSURIZE THE LINE SET AND THE INDOOR UNIT.
- E. AFTER A FEW MINUTES, OPEN ONE OF THE SERVICE VALVE PORTS AND VERIFY THAT THE REFRIGERANT ADDED TO THE SYSTEM EARLIER IS MEASURABLE WITH A LEAK DETECTOR. ONCE LEAK DETECTOR IS CONFIRMED OPERATIONAL, LEAK CHECK THE ENTIRE SYSTEM (FIELD JOINTS AND LINE SET INCLUDED) TO A SENSITIVITY OF 5 GRAMS PER YEAR OF REFRIGERANT.
- F. AFTER LEAK TESTING, DISCONNECT GAUGES FROM SERVICE PORTS.

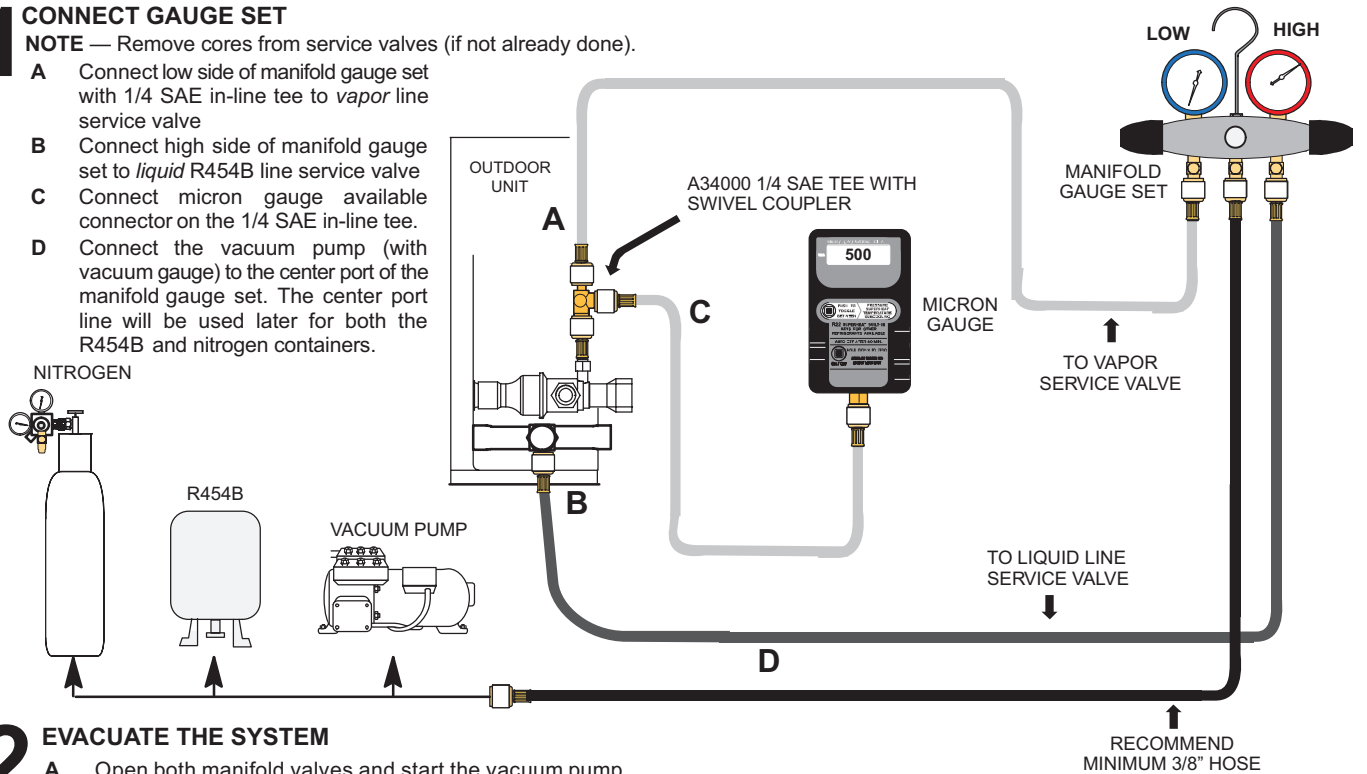
**FIGURE 11. System Leak Test**

## Evacuating Line Set and Indoor Coil

### 1 CONNECT GAUGE SET

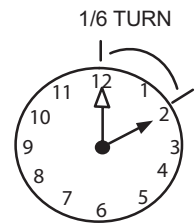
**NOTE** — Remove cores from service valves (if not already done).

- A** Connect low side of manifold gauge set with 1/4 SAE in-line tee to vapor line service valve
- B** Connect high side of manifold gauge set to liquid R454B line service valve
- C** Connect micron gauge available connector on the 1/4 SAE in-line tee.
- D** Connect the vacuum pump (with vacuum gauge) to the center port of the manifold gauge set. The center port line will be used later for both the R454B and nitrogen containers.



### 2 EVACUATE THE SYSTEM

- A** Open both manifold valves and start the vacuum pump.
- B** Evacuate the line set and indoor unit to an **absolute pressure** of 23,000 microns (29.01 inches of mercury).
  - NOTE** — During the early stages of evacuation, it is desirable to close the manifold gauge valve at least once. A rapid rise in pressure indicates a relatively large leak. If this occurs, **repeat the leak testing procedure**.
  - NOTE** — The term **absolute pressure** means the total actual pressure within a given volume or system, above the absolute zero of pressure. Absolute pressure in a vacuum is equal to atmospheric pressure minus vacuum pressure.
- C** When the absolute pressure reaches 23,000 microns (29.01 inches of mercury), perform the following:
  - Close manifold gauge valves
  - Close valve on vacuum pump
  - Turn off vacuum pump
  - Disconnect manifold gauge center port hose from vacuum pump
  - Attach manifold center port hose to a dry nitrogen cylinder with pressure regulator set to 160 psig (1103 kPa) and purge the hose.
  - Open manifold gauge valves to break the vacuum in the line set and indoor unit.
  - Close manifold gauge valves.
- D** Shut off the dry nitrogen cylinder and remove the manifold gauge hose from the cylinder. Open the manifold gauge valves to release the dry nitrogen from the line set and indoor unit.
- E** Reconnect the manifold gauge to the vacuum pump, turn the pump on, and continue to evacuate the line set and indoor unit until the absolute pressure does not rise above 500 microns (29.9 inches of mercury) within a 20-minute period after shutting off the vacuum pump and closing the manifold gauge valves.
- F** When the absolute pressure requirement above has been met, disconnect the manifold hose from the vacuum pump and connect it to an upright cylinder of R454B refrigerant. Open the manifold gauge valve 1 to 2 psig in order to release the vacuum in the line set and indoor unit.
- G** Perform the following:
  - Close manifold gauge valves.
  - Shut off R454B cylinder.
  - Reinstall service valve cores by removing manifold hose from service valve. Quickly install cores with core tool while maintaining a positive system pressure.
  - Replace stem caps and secure finger tight, then tighten an additional one-sixth (1/6) of a turn as illustrated.



**FIGURE 12. Evacuating the System**

## **⚠ IMPORTANT**

Use a thermocouple or thermistor electronic vacuum gauge that is calibrated in microns. Use an instrument capable of accurately measuring down to 50 microns.

## **⚠ WARNING**

Possible equipment damage.

Avoid deep vacuum operation. Do not use compressors to evacuate a system. Extremely low vacuum can cause internal arcing and compressor failure. Damage caused by deep vacuum operation will void warranty.

Evacuating the system of non-condensables is critical for proper operation of the unit. Non-condensables are defined as any gas that will not condense under temperatures and pressures present during operation of an air conditioning system. Non-condensables and water suction combine with refrigerant to produce substances that corrode copper piping and compressor parts.

### **ELECTRICAL – Circuit Sizing and Wire Routing**

In the U.S.A., wiring must conform with current local codes and the current National Electric Code (NEC). In Canada, wiring must conform with current local codes and the current Canadian Electrical Code (CEC).

Refer to the furnace or air handler installation instructions for additional wiring application diagrams and refer to unit nameplate for minimum circuit ampacity and maximum overcurrent protection size.

#### **24VAC TRANSFORMER**

Use the transformer provided with the furnace or air handler for low-voltage control power (24VAC - 40 VA minimum).

### **Thermostat Control and Low Voltage Control Wiring**

#### **EL19KPV Thermostat Control Options**

The EL19KPV variable capacity units provide two thermostat control options to provide application and installation flexibility.

#### **S40 Communicating Thermostat Control**

The EL19KPV variable capacity unit may be installed as a fully communicating system consisting of S40 Ultra Smart Communicating Thermostat, an indoor unit and the EL19KPV variable capacity outdoor unit wired with (4) communication wires (R, I+, I- and C) connected to the EL19KPV Outdoor Unitary Control.

The EL19KPV variable capacity unit when wired as a fully communicating system will take full advantage of the advanced diagnostics and control, Wi-Fi accessibility and system operation parameters. Refer to the EL19KPV field wiring diagram for an S40 communicating thermostat.

#### **Conventional 24VAC Non-Communicating Thermostat Control**

The EL19KPV variable capacity unit may be installed using a conventional 24VAC non-communicating two-stage heat pump thermostat.

**NOTE** – *The conventional 24VAC non-communicating thermostat must have a compressor minimum on time of three minutes to prevent compressor short cycling. The Lennox M30, ComfortSense 7500, ComfortSense 3000 and many other commercially available electronic thermostats provide this feature.*

The EL19KPV unit will provide full variable capacity operation when installed with a conventional 24VAC non-communicating two stage heat pump or single-stage heat pump thermostat. The EL19KPV outdoor control has advanced control algorithms using the EL19KPV suction pressure sensor to provide true variable capacity operation in the cooling mode. In the heat pump heating mode, the advanced control algorithms uses the EL19KPV liquid pressure sensor to provide true variable capacity operation.

When utilizing a two-stage conventional 24VAC non-communicating heat pump thermostat, six wires are required to control the outdoor unit (R, C, Y1, Y2, O and W). Refer to the EL19KPV field wiring diagram for a conventional 24VAC non-communicating 2-stage heat pump thermostat.

#### **EL19KPV Low Voltage Control Wiring Connections**

The EL19KPV variable capacity units are provided with (2) RAST 6-Pin connections in the installation instruction bag for connecting the field low voltage control wiring to the EL19KPV harnesses in the low voltage control make-up box. One RAST 6-pin connector is labeled with terminals TST, DF, R, I+, I- and C. The second RAST 6-pin connector is labeled with terminals DS, O, Y1, Y2, L and W.

## **⚠ WARNING**



Electric Shock Hazard. Can cause injury or death. Unit must be properly grounded in accordance with national and local codes.

Line voltage is present at all components when unit is not in operation on units with single-pole contactors. Disconnect all remote electric power supplies before opening access panel. Unit may have multiple power supplies.

## **⚠ WARNING**

Fire Hazard. Use of aluminum wire with this product may result in a fire, causing property damage, severe injury or death. Use copper wire only with this product.

# ⚠ WARNING

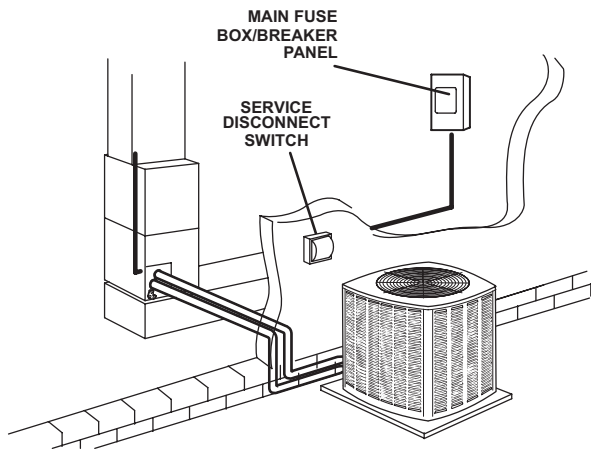
Failure to use properly sized wiring and circuit breaker may result in property damage. Size wiring and circuit breaker(s) per Product Specifications bulletin (EHB) and unit rating plate.

## EL19KPV Thermostat Control Options

Thermostat Type	Indoor Unit Type	Qty. of Wires to EL19KPV	EL19KPV Terminal Strip Connections	Unit Operation	Field Wiring Diagram
S40 Communicating Thermostat	Communicating Gas Furnace or Air Handler	4	R, I+, I-, C	Fully Communicating Variable Capacity Operation Based Upon Thermostat Demand	Figure 15
Conventional 24VAC 2-Stage Heat Pump Thermostat (non-communicating)	Any Furnace or Air Handler (non-communicating or communicating)	6	R, C, Y1, Y2, O, W	Full Variable Capacity Operation Controlled by EL19KPV Unitary Control Using Suction Pressure in Cooling Mode and Liquid Pressure in Heating Mode	Figure 16

### 1 SIZE CIRCUIT AND INSTALL SERVICE DISCONNECT SWITCH

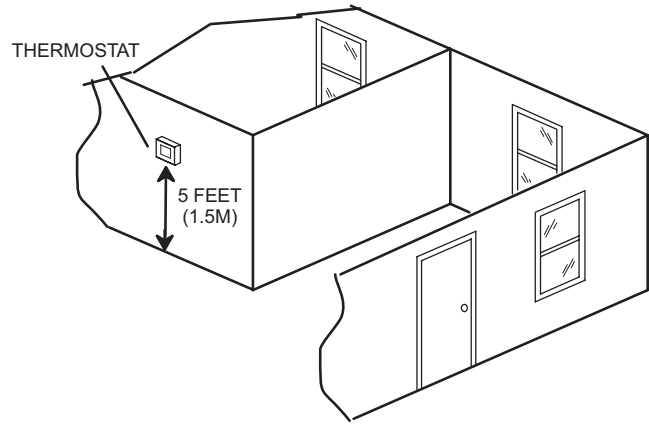
Refer to the unit nameplate for minimum circuit ampacity, and maximum fuse or circuit breaker (HACR per NEC). Install power wiring and properly sized disconnect switch.



**NOTE** - Units are approved for use only with copper conductors. Ground unit at disconnect switch or connect to an earth ground.

### 2 INSTALL THERMOSTAT

Install room thermostat (ordered separately) on an inside wall approximately in the center of the conditioned area and 5 feet (1.5m) from the floor. It should not be installed on an outside wall or where it can be affected by sunlight or drafts.



**NOTE** - 24VAC, Class II circuit connections are made in the control panel.

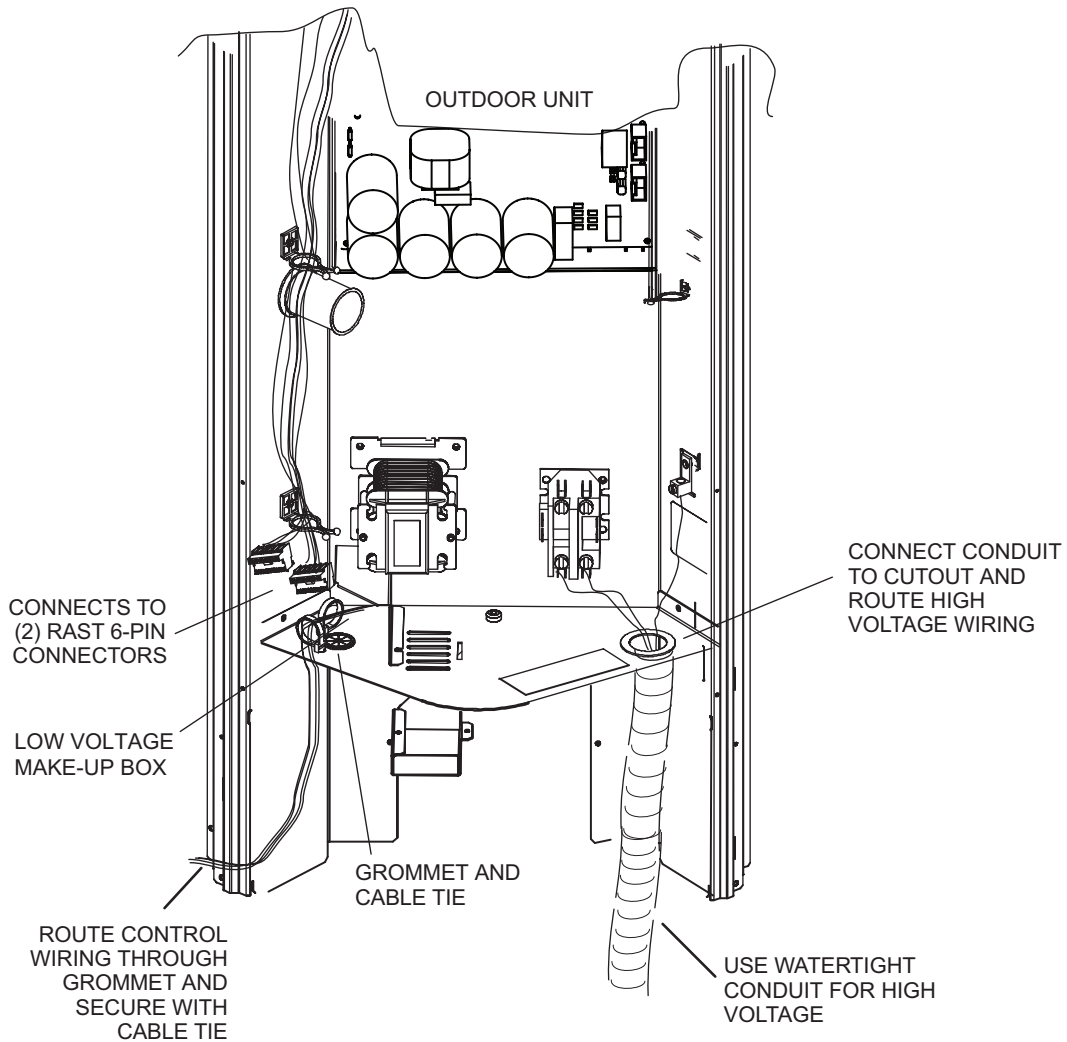
### 3 ROUTE CONTROL WIRES

#### Communicating Thermostat Wiring

Maximum length of wiring (18 gauge) for all connections on the RSBus is 1500 feet (457 meters). Wires should be color-coded, with a temperature rating of 95°F (35°C) minimum, and solid-core (Class II Rated Wiring). All low voltage wiring must enter unit through field-provided field-installed grommet installed in electrical inlet.

#### Conventional 24VAC Non-Communicating Thermostat Wiring

WIRE RUN LENGTH	AWG#	INSULATION TYPE
LESS THAN 100' (30 METERS)	18	TEMPERATURE RATING
MORE THAN 100' (30 METERS)	16	35°C MINIMUM.

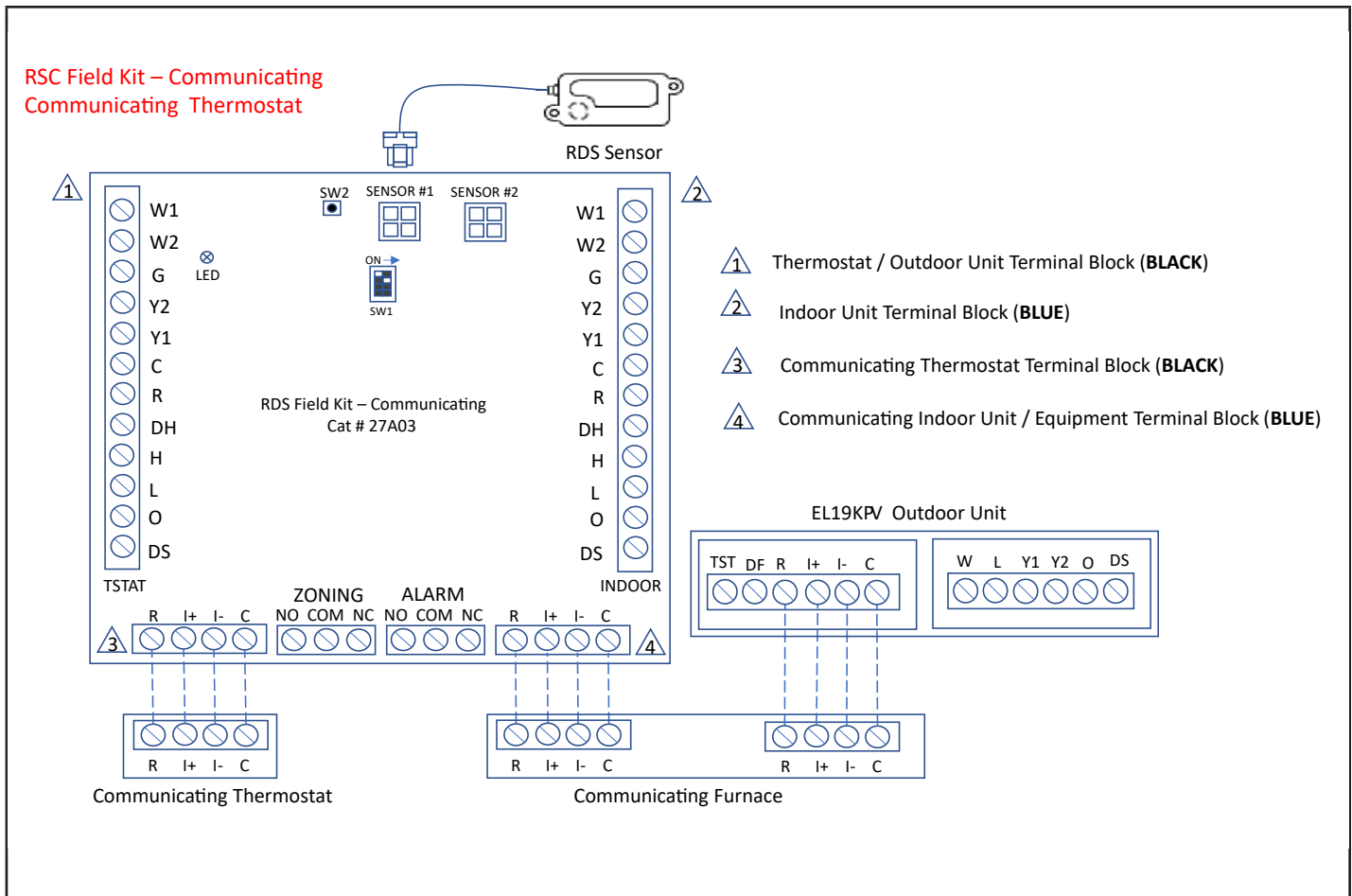


### 4 ROUTE HIGH VOLTAGE AND GROUND WIRES

Any excess high voltage field wiring should be trimmed and secured away from any low voltage field wiring. To facilitate a conduit, a cutout is located on the bottom of the control box. Connect conduit to the control box using a proper conduit fitting.

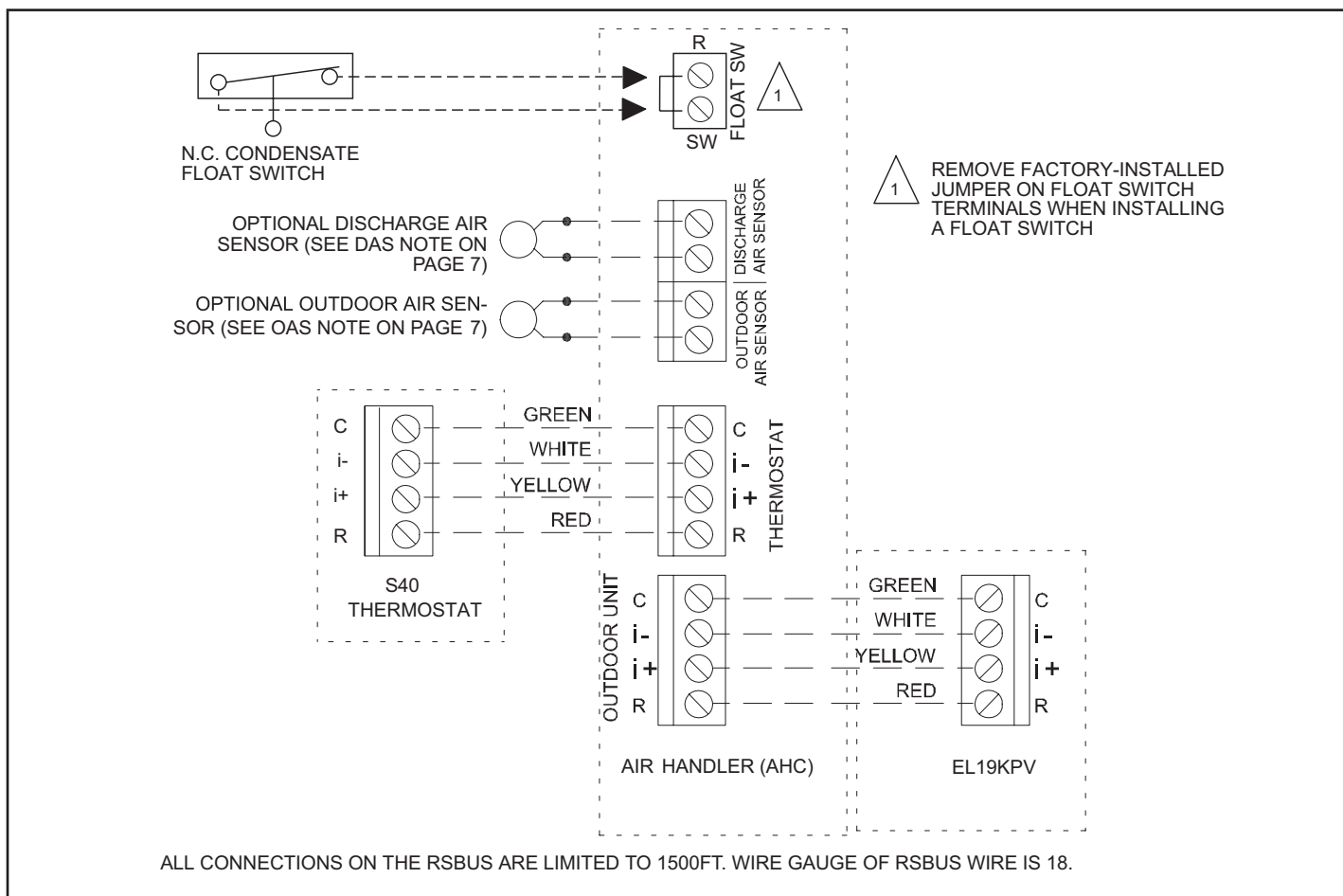
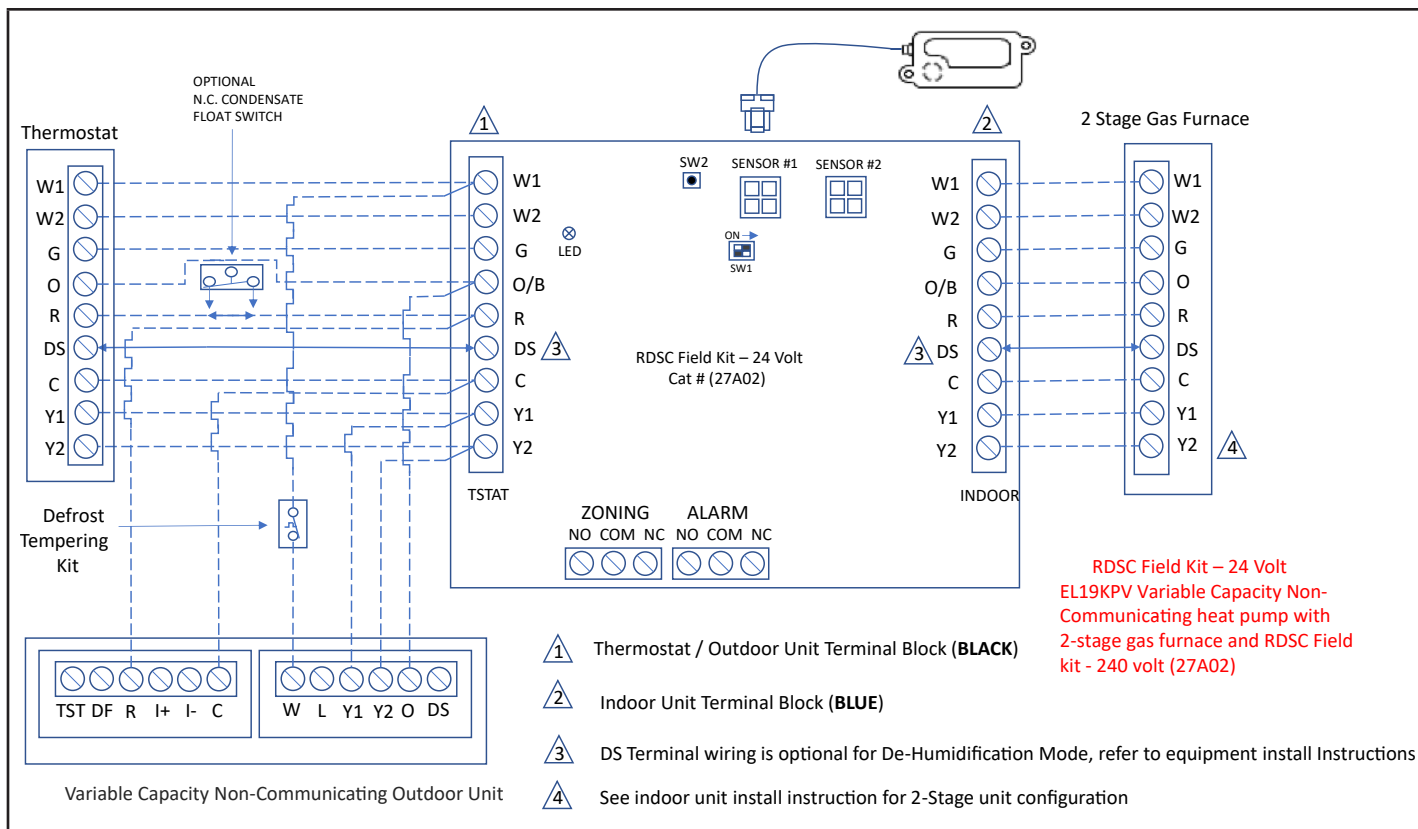
Connect the 208/230 high voltage power supply from the disconnect to the EL19KPV contactor as shown. Connect the ground wire from the power supply to the unit ground lug connection.

FIGURE 13. Typical Control Wiring

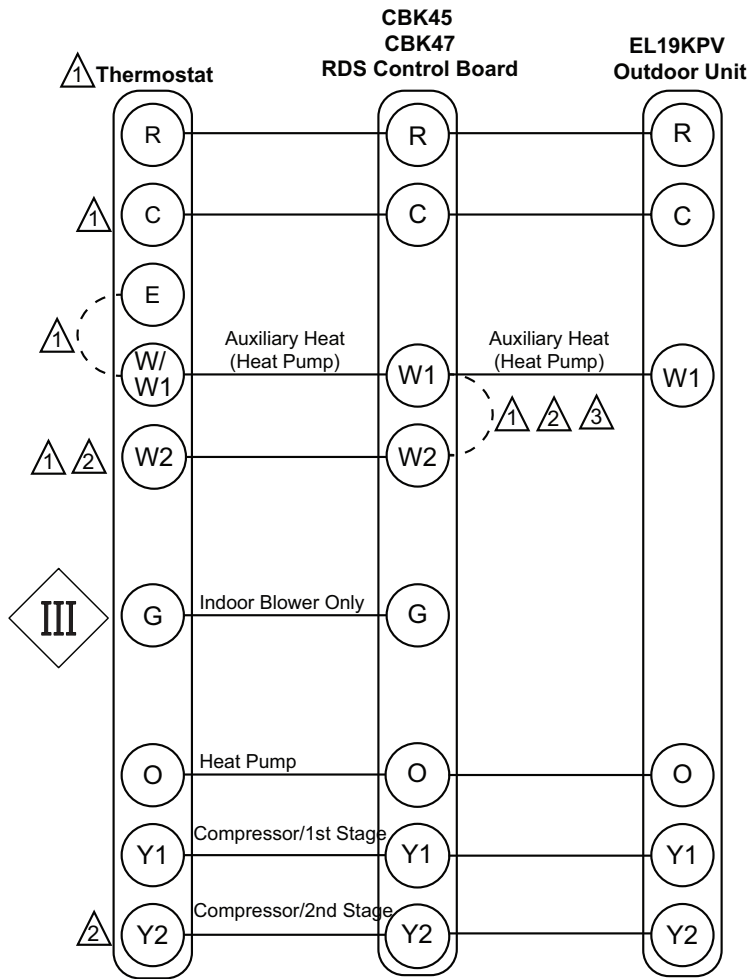





**FIGURE 14. EL19KPV with Communicating Gas Furnace, 27A03 RDS-Field Kit – Communicating and S40 Communicating Thermostat - Field Wiring Diagram**





**FIGURE 15. EL19KPV with CBK48MVT Communicating Air Handler with RDS and S40 Communicating Thermostat**

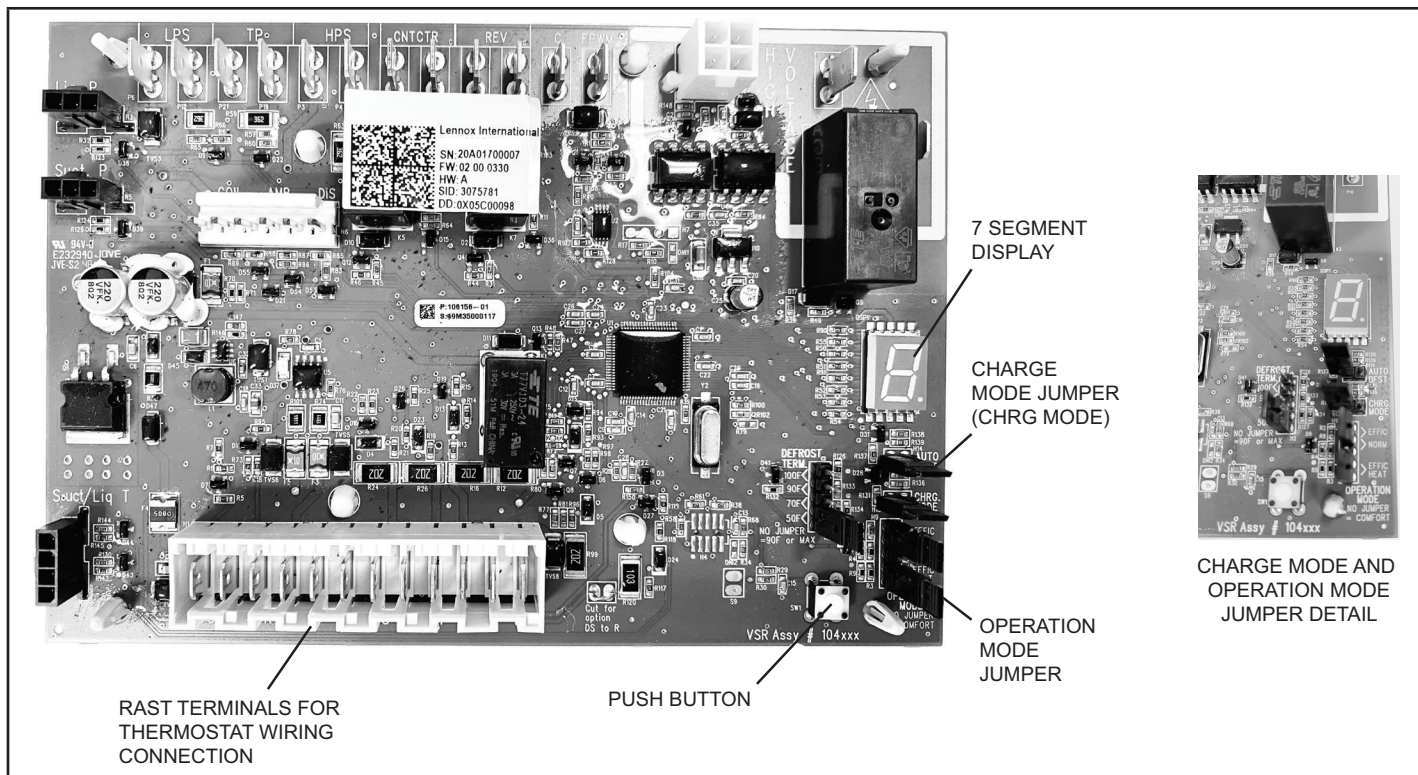


-  Refer to thermostat installation instructions
-  If applicable
-  Install jumper for single-stage operation on electric heater kits 12.5KW and above

NOTES: W1 / W2 are auxiliary heat (supplemental to heat pump).  
 "E" is emergency heat (disables heat pump).

**FIGURE 16. EL19KPV Variable Capacity Non-Communicating Heat Pump Installed with a CBK45 or CBK47 Air Handler with Factory Installed RDS Control and Conventional 24V Thermostat**

## 5 – Outdoor Unitary Control - Jumpers and Terminals



### Outdoor Control 7 Segment Display and Push Button

Information concerning the outdoor control 7-segment display and push button operations are available on the unit access panel.

### Alarms

Alarm information is provided on the unit access panel.

### Charge Mode Jumper

To initiate the EL19KPV Charge Mode function, install the jumper across the two Charge Mode Pins (CHRG MODE) on the outdoor control. The Charge Mode can be used when charging the system with refrigerant, checking the refrigerant charge, pumping down the system and performing other service procedures that requires outdoor unit operation at 100% capacity.

### EL19KPV Charge Mode Operation with a S40 Communicating Thermostat

Installing a jumper on the Charge Mode Pins will initiate compressor operation in the cooling mode and outdoor fan motor at 100% capacity and will provide a signal to the indoor unit to initiate indoor blower operation at the maximum cooling air volume. To exit the charge mode, remove the Charge Mode Jumper. The Charge Mode has a maximum time of 60 minutes and will automatically exit the charge mode after 60 minutes is the charge mode jumper is left in place.

### EL19KPV Charge Mode Operation with a Conventional 24VAC Non-Communicating Heat Pump Thermostat

On applications with a conventional 24VAC non-communicating thermostat, the charge mode jumper must be installed on the Charge Mode Pins after providing a Y1 compressor demand to the EL19KPV to initiate the Charge Mode. When using the Charge Mode in the cooling mode, the “O” must also be provided with a 24V signal to place the reversing valve in the cool position. In the heating mode only a Y1 compressor demand is required along with the blower demand for the full cooling air volume. A cooling blower demand must also be provided to initiate blower operation on the cooling speed on the indoor unit. The compressor and outdoor fan motor will operate at 100% capacity. To exit the charging mode, remove the Charge Mode Jumper and remove the Y1 Cooling demand and indoor blower demand. The Charge Mode has a maximum time of 60 minutes and will automatically exit the charge mode after 60 minutes is the charge mode jumper is left in place.

### Cooling Operation Mode Jumper

The Cooling Operation Mode Jumper is only used on applications installed with a conventional 24VAC non-communicating heat pump thermostat. In applications with a conventional 24VAC non-communicating heat pump thermostat, the compressor capacity is controlled to maintain the target suction pressure setpoint. The Cooling Operation Mode Jumper has three selectable cooling modes. The three modes are Efficiency (Jumper installed on Pins 1 and 2), Normal Mode (Jumper installed on Pins 2 and 3) and Comfort Mode (Jumper Removed). The factory default position is the Efficiency Mode.

The Efficiency mode has a variable suction pressure setpoint that will vary with the outdoor temperature; as the outdoor temperature increases the suction pressure setpoint will decrease. When the Cooling Operation Mode jumper is installed in the "Normal Mode" the suction pressure setpoint is 135 psig.

When the Cooling Operation Mode jumper is installed in the "Comfort Mode" the suction pressure setpoint is 125 psig.

### Heating Operation Mode Jumper

The Heating Operation Mode Jumper is only used on applications installed with a conventional 24VAC non-communicating heat pump thermostat. In applications with a conventional 24VAC non-communicating heat pump thermostat, the compressor capacity is controlled to maintain the target liquid pressure setpoint. The Heating Operation Mode Jumper has two selectable heating modes. The two modes are Efficiency (Jumper installed on Pins 1 and 2) and Comfort Mode (Jumper Removed). The factory default position is the Efficiency Mode. The Efficiency mode has a variable liquid pressure setpoint that will vary with the outdoor temperature; as the outdoor temperature decreases, the liquid pressure setpoint will increase. When the Operation Mode jumper is installed in the "Comfort Mode" the liquid pressure setpoint is 425 psig.

### Unit Operation

#### EL19KPV Unit Operation with a S40 Communicating Thermostat

When the EL19KPV unit is installed with a S40 Communicating Thermostat and indoor unit, the unit capacity will be controlled in the variable capacity mode throughout the range of capacity from minimum capacity to maximum capacity based upon thermostat demand in both the cooling and heat pump heating mode. The indoor air volume will be controlled to match compressor capacity throughout the capacity range.

#### EL19KPV Unit Operation with a Conventional 24VAC Non-Communicating 2-Stage Heat Pump Thermostat – Cooling Mode

When the EL19KPV unit is installed with a conventional 24VAC non-communicating 2-stage heat pump thermostat, the O terminal on the thermostat will energize the unit reversing valve to place the unit in the cooling mode. A Y1 first stage cooling demand will initiate cooling operation and first stage indoor blower operation. The compressor will be controlled in the variable capacity mode by varying the compressor capacity to obtain the target suction pressure set point. The Y2 second stage cooling demand will initiate second stage blower operation. Increased air volume will increase the load on the indoor coil and increase the suction pressure. The EL19KPV compressor capacity will continue to be controlled based upon the suction pressure. The unit capacity will be controlled in the variable capacity mode throughout the range of capacity from minimum capacity to maximum capacity. If the Y2 demand remains after 20 minutes, the EL19KPV control will begin to ramp up the compressor capacity until maximum capacity is achieved. The EL19KPV unit will cycle off once the thermostat demand is satisfied.

#### EL19KPV Unit Operation with a Conventional 24VAC Non-Communicating 2-Stage Heat Pump Thermostat - Heating Mode

When the EL19KPV unit is installed with a conventional 24VAC non-communicating 2-stage heat pump thermostat, O terminal is not powered during the heating mode and the reversing valve is de-energized placing the unit in the heating mode. A Y1 first stage compressor demand will initiate compressor operation and first stage indoor blower operation. The compressor will be controlled in the variable capacity mode by varying the compressor capacity to obtain the target liquid pressure set point. The Y2 second stage compressor demand will initiate second stage blower operation. Increased air volume will increase heat transfer on the indoor coil and decrease the liquid pressure. If the liquid pressure drops below the target setpoint, the compressor capacity will be increased. The EL19KPV compressor capacity will continue to be controlled based upon the liquid pressure. The unit capacity will be controlled in the variable capacity mode throughout the range of capacity from minimum capacity to maximum capacity. If the Y2 demand remains after 20 minutes, the EL19KPV control will begin to ramp up the compressor capacity until maximum capacity is achieved. The EL19KPV unit will cycle off once the thermostat demand is satisfied.

### Defrost Function

The outdoor unit control uses a time dependent frost accumulation duration demand defrost control algorithm to provide a demand defrost when the system falls below optimum levels. The demand defrost control algorithm is reactive based upon the previous heat pump run time between defrost cycles (frost accumulation time) and the time spent in defrost (defrost time). The outdoor unit control monitors ambient temperature, outdoor coil temperature along with the compressor run time in heating mode and defrost cycle time. The outdoor unit control monitors compressor run time in the heating mode when the outdoor coil temperature is below 35°F and accumulates the frost accumulation time. Once the frost accumulation time is met the unit control will initiate a defrost cycle. The unit will run in the defrost mode until the coil temperature reaches the defrost termination temperature setpoint. The maximum length of defrost cycle is 14 minutes and the defrost cycle will automatically be terminated if the defrost cycle exceeds 14 minutes.

Two consecutive low pressure switch trips while operating in the heat pump heating mode will initiate a defrost cycle to defrost that may occur during a weather-related event such as freezing rain.

#### Frost Accumulation Time

The frost accumulation time is the amount of time the heat pump runs in the heating mode when the outdoor coil temperature is below 35°F. The initial target frost accumulation time is 90 minutes, but the control will adjust the frost accumulation time higher or lower based upon the previous defrost cycle time history. If the defrost cycle time is short (80% or less of the defrost cycle time) the defrost accumulation time will be increased by 30 minutes.

If the defrost cycle time is long (120% or more of the target defrost cycle time) the defrost accumulation time will be decreased by 30 minutes. If the defrost accumulation time is significantly longer (200% or more of the target defrost cycle time) or if the defrost terminates at the 14-minute maximum time, the frost accumulation time is set to 30 minutes. No change to frost accumulation time is made if the frost accumulation time is close to the target defrost cycle time (between 80% and 120% of the target defrost cycle time).

### Low Ambient Defrost

When outdoor temperature is less than 10°F, the Frost Accumulation Time will be set to 360 minutes. When the outdoor temperature is extremely cold, there is less moisture in the air, which reduces the defrost frequency requirements. Setting the frost accumulation time to 360 minutes will reduce the defrost cycle frequency which will increase the overall system efficiency and minimize operation costs. The Low Ambient Defrost had adjustable parameters, allowing the technician to make adjustments for the special application and climate.

### Defrost Cycle Time

The defrost cycle time is the amount of time the unit operates in the defrost mode from the point the defrost cycle was initiated until the coil temperature reaches 50°F regardless of defrost termination temperature setpoint. The demand defrost control target defrost cycle time is unique for each EL19KPV heat pump model. The target defrost cycle time of EL19KPV-024 is 120s, EL19KPV-036 is 125s, EL19KPV-048 is 130s, EL19KPV-060 is 135s.

### Defrost Termination Temperature

The defrost termination temperature is adjustable using the S40 thermostat when the EL19KPV is installed with a S40 communicating thermostat. The Defrost Termination Jumper on the Unitary Control is ignored when installed with a S40 communicating thermostat. The Defrost Termination parameter may be adjusted at the thermostat using the dealer control center under the heat pump or remotely using the Service Dashboard on LennoxPros. The defrost termination setting selections are 50, 70, 90 and 100°F. The factory default setting is 50°F (10°C). The defrost termination temperature is monitored by the coil sensor which is located at the outlet of the outdoor expansion valve.

The coil temperature sensor is designed with a spring clip to secure the sensor to the outdoor TXV distributor. The location of the coil sensor is important for proper defrost operation.

**NOTE** - The outdoor unit control accurately measures the performance of the system as frost accumulates on the outdoor coil. This typically translates into longer running time between defrost cycles as more frost accumulates on the outdoor coil before the outdoor control initiates defrost cycles.

**NOTE** – Colder climates may require a higher defrost termination temperature setting to ensure the outdoor coil is cleared of frost during defrost. If the outdoor coil is not adequately cleared of frost, the heat pump may experience reduced heating performance or damage to the outdoor coil from the buildup of ice on the coil.

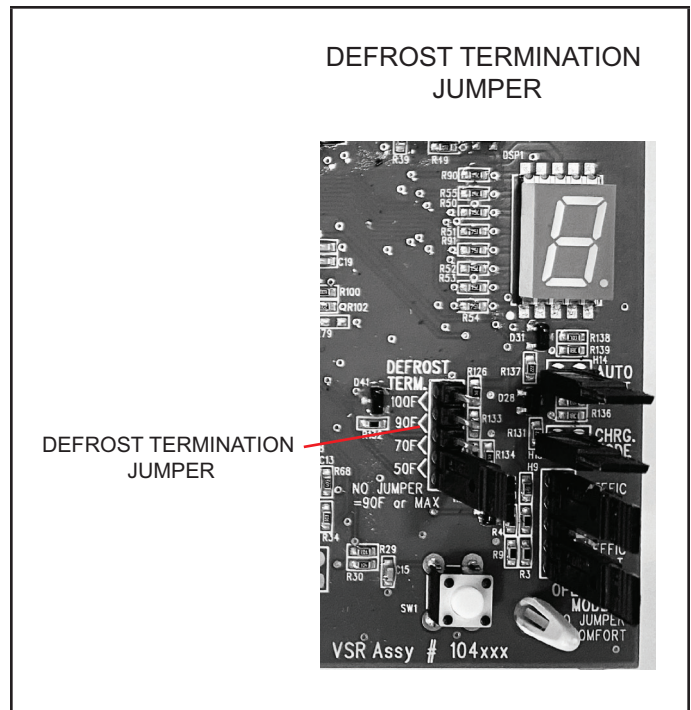


FIGURE 17

### Additional Adjustable Defrost Parameters – S40 Thermostat Only

EL19KPV systems installed with an S40 thermostat have additional adjustable defrost parameter that may be set by the technician.

- Defrost Time Adder – Range 5 – 60 minutes – default 30 minutes
- Defrost Time Reducer – Range 5 – 60 minutes – default 30 minutes
- Default Frost Accumulation Time – Range 30 – 360 minutes – default 90 minutes
- Defrost Time Increase Value – Range 0% to 100% – default 80%
- Defrost Time Decrease Value – Range 100% to 200% – default 120%
- Defrost Time Reset Limit – Range 150% to 400% – default 200%
- Nominal Defrost Time – Range 20 – 840 seconds – default EL19KPV-024 – 120s, 036 – 125s, 048 – 130s, 060 – 135s

### EL19KPV Installations with a Conventional 24VAC Heat Pump Thermostat

The unitary control has a defrost termination jumper to set the defrost termination temperature using the jumper on the unitary control. The defrost termination jumper setting selections are 50, 70, 90 and 100°F. The factory default setting is 50°F (10°C).

## Defrost Termination Temperature Setting Parameter in the S40

The screenshot shows the 'Equipment' settings for a 'Heat Pump'. The 'Defrost Termination Temp' parameter is highlighted with a red box. The settings for this parameter are: Range: 50.0 - 100.0 F, Default: 50.0 F, Inc: 10.0 F, and the current value is 50.0 F. Other parameters shown include Compressor Short Cycle Delay, Automatic Max Defrost, Max Defrost By Weather, High Normal Cooling Airflow, Low Normal Cooling Airflow, and High Normal HP Heating Airflow.

### Defrost Test

The EL19KPV defrost cycle can be tested for defrost diagnostic purposes or during service procedures to initiate a defrost cycle to clear the outdoor coil of frost or ice. The EL19KPV may be placed into a forced defrost mode by using the Outdoor Unitary Control push button.

#### To Initiate a Forced Defrost Cycle Using the Unitary Control Push Button

- 1 - While the EL19KPV is operating in the heating mode, press bush button until solid "-" is displayed to enter Field Test Mode and then release the button.
- 2 - Press and hold the button until "d" is displayed for forced defrost cycle, then release the button. Press the button again while the display is flashing "d" to select the forced defrost mode.
- 3 - The EL19KPV will enter a forced defrost cycle and "d" + "F" will be displayed on the 7-segment display.
- 4 - The 30-second Shift Delay will be observed. The

compressor and outdoor fan will cycle off. After a 4-second delay, the reversing valve will be energized and will shift to the "cool" position. After a 26-second delay, the compressor will restart and will run at the maximum cooling speed in the defrost cycle to defrost the coil.

- 5 - Coil "c" and Ambient "A" temperature will be displayed on the 7-segment display.

#### The Forced Defrost Cycle will end when any of the following conditions are met:

- The defrost cycle will terminate upon reaching the defrost termination temperature setting set on Unitary Control/
- Defrost cycle will terminate at the maximum allowable defrost time of 14 minutes has been reached.
- The defrost cycle will terminate after 10 seconds if the outdoor ambient temperature is 65°F or greater to prevent opening of the the high pressure switch.
- The unitary control push button is pressed to terminate the forced defrost cycle test.

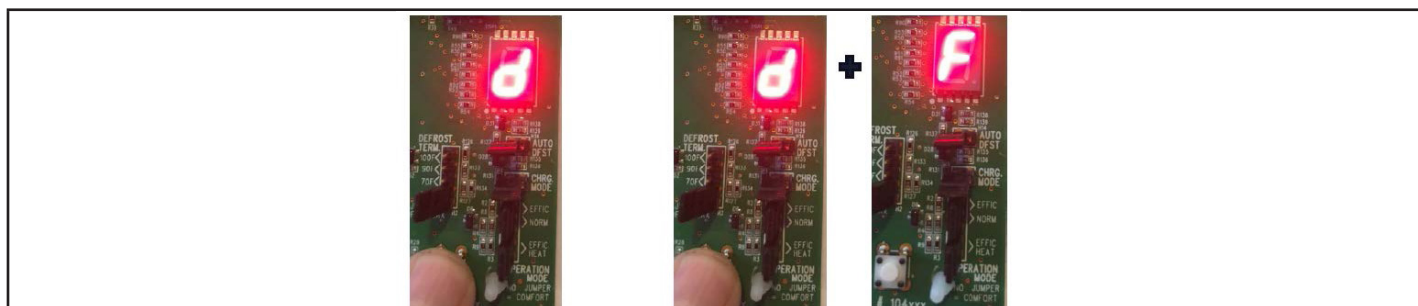


TABLE 6

Outdoor Control Terminal Designations and Input /Outputs (see figures 14 and 15 for terminal locations)				
Designator	Description	Input	Output	Common
O	O Reversing Valve Input (24VAC conventional Heat Pump Thermostats only)	24VAC	Switched 24VAC nominal	N/A
REV	Reversing valve output	N/A	24VAC Nominal	24VAC common
LPS	Not used on EL19KPV (Suction Pressure Transducer emulates the LPS)	N/A	N/A	N/A
LPS	Not used on EL19KPV (Suction Pressure Transducer Emulates the LPS)	24VAC Nominal	N/A	N/A
HPS	High pressure switch	N/A	24VAC nominal	N/A
HPS	High pressure switch sensing connection	24VAC nominal	N/A	N/A
TP	Top cap thermostat switch (in series with the HPS)	N/A	24VAC nominal	N/A
TP	Top cap thermostat switch sensing connection	24VAC nominal	N/A	N/A
Cntctr	Control (inverter power) contactor switched output (in series with the HPS and TC)	N/A	Switched 24VAC nominal	N/A
Cntctr	Contactor common	N/A	N/A	24VAC common
FPWM	PWM fan output	N/A	10-97% duty cycle, 19-23 VDC peak	N/A
C	PWM fan common connection	N/A	N/A	Fan PWM common
P10 (PSC Fan 1/4" QC)	1/4" QC terminals - Switched output for PSC outdoor fan control (not used on EL19KPV heat pumps)	N/A	Switched 230VAC Nominal	N/A
RAST Connector Terminal Designations				
W	24VAC Output for defrost auxiliary heat output	N/A	24VAC nominal	N/A
L	24VAC input to initiate load shed	24VAC nominal from load shed N.O. contacts (close to initiate load shed)	N/A	N/A
Y2	Y2 second stage cooling input when a conventional 24VAC non-communicating thermostat is used.	24VAC nominal from thermostat	N/A	N/A
Y1	Y1 first stage cooling input when a conventional 24VAC non-communicating thermostat is used	24VAC nominal from thermostat	N/A	N/A
O	O Reversing Valve Input (24VAC conventional Heat Pump Thermostats only)	24VAC nominal from thermostat	N/A	N/A
DS	Dehumidification input - not used	N/A	N/A	N/A
C	24VAC nominal power return	N/A	N/A	24VAC common
I-	Low data line	Data	Data	N/A
I+	High data line	Data	Data	N/A
R	24VAC nominal power input	24VAC nominal board main power input	N/A	N/A
DF	OEM test	N/A	N/A	N/A
TST	OEM test pin	24VAC nominal	N/A	N/A

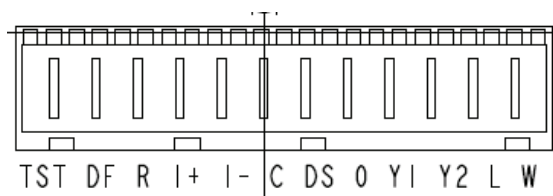


Table 6 continued

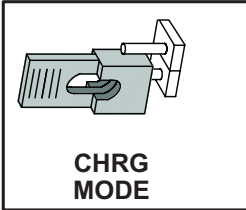
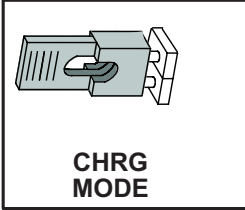
Outdoor Control Terminal Designations and Inputs / Outputs					
<b>WARNING</b> - Electric Shock Hazard. Can cause injury or death. Unit must be grounded in accordance with national and local codes. The 4 pins in P6 have the potential of transferring up to 250 volts to the unit cabinet ground.					
Designator		Description	Input	Output	Common
P6 - Pin 1	Tx	Transmit data to inverter, connects to Rx of inverter	Outdoor control communication transmit pin	- Pin 1 to pin 2 should read 4.5 to 5.55 VDC when not communicating - Pin 3 to pin 2 should read 4.5 to 5.55 VDC when not communicating - Pin 4 to pin 2 should read 4.5 to 5.5 VDC NOTE - Communication signals switch off and on rapidly. This may cause volt meter readings to fluctuate. This is normal. Communication signals will switch between this 5V and common (Pin 2).	
P6 - Pin2	Inverter Common	Inverter common NOTE – This is a signal reference point and not an earth ground.	Inverter common		
P6 - Pin 3	Rx	Receive data from the inverter Connects to Tx of inverter	Outdoor control communication receive pin		
P6 - Pin 4	Inv 5V	Inverter 5VDC volts	Inverter 5VDC volts		
DIS		Discharge Line temperature sensor - not used (10K ohm resistor installed)	N/A	N/A	N/A
DIS		Discharge Line temperature sensor - not used (10K ohm resistor installed)	N/A	N/A	N/A
AMB		Outdoor ambient temperature sensor supply	N/A	N/A	N/A
AMB		Outdoor ambient temperature sensor return	N/A	N/A	N/A
COIL		Outdoor coil temperature sensor - not used (10K ohm resistor installed)	N/A	N/A	N/A
COIL		Outdoor coil temperature sensor - not used (10K ohm resistor installed)	N/A	N/A	N/A
CHRG MODE		<p>Charge Mode function. Can be used when charging, checking charge, pump down or checking unit operation. Unit will run at 100% capacity.</p> <p>Conventional 24VAC heat pump thermostat - Cooling mode</p> <ol style="list-style-type: none"> <li>1. Provide a Y1 compressor demand and a O Reversing Valve signal to the EL19KPV</li> <li>2. Install the Charge Mode jumper (after the Y1 demand)</li> <li>3. A blower demand must be provided to the indoor unit for 100% of the cooling air volume.</li> <li>4. Remove the charge mode jumper to end the charge mode</li> </ol> <p>Conventional 24VAC Heat Pump Thermostat - Heating Mode</p> <ol style="list-style-type: none"> <li>1. Provide a Y1 compressor heating demand (without an O demand)</li> <li>2. Install the Charge Mode jumper (after the Y1 demand)</li> <li>3. A blower demand must be provided to the indoor unit for 100% of the heating air volume.</li> <li>4. Remove the charge mode jumper to end the charge mode.</li> </ol> <p>S40 Communicating Thermostat</p> <ol style="list-style-type: none"> <li>1. Install the Charge Mode jumper</li> <li>2. Unit will start and run at 100% capacity and communicate to the indoor unit to bring on the blower at 100% of the cooling air volume.</li> <li>4. Remove the charge mode jumper to end the charge mode</li> </ol> <p>NOTE - If the charge mode jumper is in the ON position during power-up, it is ignored.</p> <p>NOTE - If the charge mode is left in place, it will be ignored after 60 minutes.</p>	<p><b>Charge Mode Disabled</b></p>  <p><b>CHRG MODE</b></p>	<p><b>Charge Mode Enabled</b></p>  <p><b>CHRG MODE</b></p>	



Table 6 continued

Designator	Description	Input	Output	Common
Suction Pressure Out	Pressure transducer Supply Voltage Pin 1 of 3		5 VDC	
Suction Pressure In	Pressure transducer output voltage Pin 2 of 3	0.5-4.5 VDC		
Suction Pressure GND	Pressure transducer GND Pin 3 of 3			VDC Com
Liquid Pressure Out	Pressure transducer Supply Voltage Pin 1 of 3		5 VDC	
Liquid Pressure In	Pressure transducer Supply Voltage Pin 2 of 3	0.5-4.5 VDC		
Liquid Pressure GND	Pressure transducer GND Pin 3 of 3			VDC Com
SUCT1	Suction Line Temperature Sensor Supply - Pin 1 of 4	2.680k ohms to 327.3k ohms		
SUCT2	Suction Line Temperature Sensor Supply - Pin 2 of 4	2.680k ohms to 327.3k ohms		
LIQ1	Liquid Line Temperature Sensor Supply - Pin 3 of 4	2.680k ohms to 327.3k ohms		
LIQ2	Liquid Line Temperature Sensor Supply - Pin 4 of 4	2.680k ohms to 327.3k ohms		

### Unit Start-Up

## IMPORTANT

If unit is equipped with a crankcase heater, it should be energized 24 hours before unit start-up to prevent compressor damage as a result of slugging.

- 1 - Rotate fan to check for binding.
- 2 - Inspect all factory- and field-installed wiring for loose connections.
- 3 - After evacuation is complete, open both the liquid and vapor line service valves to release the refrigerant charge contained in outdoor unit into the system.
- 4 - Replace the stem caps and tighten to the value listed in table 1.
- 5 - Check voltage supply at the disconnect switch. The voltage must be within the range listed on the unit's nameplate. If not, do not start the equipment until you have consulted with the power company and the voltage condition has been corrected.
- 6 - Set the thermostat for a cooling demand. Turn on power to the indoor unit and close the outdoor unit disconnect switch to start the unit.
- 7 - Recheck voltage while the unit is running. Power must be within range shown on the nameplate.
- 8 - Check system for sufficient refrigerant by using the procedures listed in the System Refrigerant section on page 85.

## System Operation and Service

### 7-SEGMENT ALERT AND SYSTEM STATUS CODES

Alert codes are displayed using the 7-segment display located on the outdoor control.

NOTE - System fault and lockout codes take precedence over system status codes (cooling, heating operating percentages or defrost/dehumidification).

The 7-segment will display an abnormal condition (error code) when detected in the system. A list of the codes are shown in table 7.

#### Resetting Alert Codes

Alert codes can be reset manually or automatically:

##### 1 - Manual Reset

Manual reset can be achieved by one of the following methods:

- Disconnecting R wire from the outdoor control R terminal.
- Turning the indoor unit off and back on again

After power up, all currently displayed codes are cleared.

##### 2 - Automatic Reset

After an alert is detected, the outdoor control continues to monitor the unit's system and compressor operations. When/if conditions return to normal, the alert code is turned off automatically.

NOTE - Error codes can be recalled by following information shown in the following tables.

**TABLE 7. Outdoor Control 7-Segment Display Alert Codes and Inverter LED Flash Codes**

**NOTE** – System fault and lockout codes take precedence over system status codes (cooling, heating operating percentages or defrost/dehumidification). Only the latest active fault or lockout codes are displayed (if present). If no fault or lockout codes are active, then system status codes are displayed. Alert codes are also displayed on the S40 thermostat.

Alert Codes	Inverter Code	Inverter LED Flash Code (number of flashes)		Priority	Alarm Description	Possible Causes and Clearing Alarm
		Red LED	Green LED			
N/A	N/A	ON	OFF	N/A	EL19KPV-024, -036 only: Indicates inverter is operating normally.	
N/A	N/A	ON	ON	N/A	EL19KPV-048, -060 only: Indicates inverter is operating normally.	
N/A	N/A	OFF	OFF	N/A	Indicates inverter is NOT energized.	
E105	N/A	N/A	N/A	Service Soon	The outdoor control has lost communication with either the thermostat or indoor unit.	Equipment is unable to communicate. Indicates numerous message errors. In most cases errors are related to electrical noise. Make sure high voltage power is separated from RSBUS. Check for miswired and/or loose connections between the stat, indoor unit and outdoor unit. Check for a high voltage source of noise close to the system. Fault clears after communication is restored.
E120	N/A	N/A	N/A	Service Soon	There is a delay in the outdoor unit responding to the system.	Typically, this alarm/code does not cause any issues and clears on its own. The alarm/code is usually caused by a delay in the outdoor unit responding to the thermostat. Check all wiring connections. Cleared after unresponsive device responds to any inquiry.
E124	N/A	N/A	N/A	Service Urgent	The S40 thermostat has lost communication with the outdoor unit for more than 3 minutes.	Equipment lost communication with the thermostat. Check the wiring connections and resistance, then cycle the system power. This alarm stops all associated HVAC operations and waits for a signal from the non-communicating unit. The alarm / fault clears after communication is re-established.
E125	N/A	N/A	N/A	Service Urgent	There is a hardware problem with the outdoor control.	There is a control hardware problem. Replace the outdoor control if the problem prevents operation and is persistent. The alarm / fault is cleared 300 seconds after the fault recovers.
E131	N/A	N/A	N/A	Service Urgent	The outdoor unit control parameters are corrupted.	Reconfigure the system. Replace the control if heating or cooling is not available.
E132	N/A	N/A	N/A	Service Urgent	Internal software error.	Replace outdoor control.
E180	N/A	N/A	N/A	Service Urgent	The outdoor unit ambient temperature sensor has malfunctioned. As a result the outdoor unit control will not perform low ambient cooling.	Valid temperature reading is lost during normal operation and after outdoor control recognized sensors. Compare outdoor sensor resistance to temperature/ resistance charts in unit installation instructions. Replace sensor pack if necessary. At the beginning of (any) configuration, furnace or airhandler control detects the presence of the sensor(s). If detected (reading in range), appropriate feature is shown in the S40 thermostat About screen. The alarm / fault clears upon configuration, or when normal values are sensed.
E181	N/A	N/A	N/A	Service Soon	Suction pressure transducer fault.	Suction pressure transducer is out of range. The signal should be between 0.5 VDC and 4.5 VDC between blue and black. The error code will be cleared when proper signal is provided. System controlled by a conventional 24VAC heat pump thermostat will operate in the staged mode.
E182	N/A	N/A	N/A	Service Soon	Suction temperature sensor has malfunctioned.	Check temperature sensor in the applicable installation and service procedure. Nominal resistance is 10K Ohms at 77F.

**TABLE 7. Outdoor Control 7-Segment Display Alert Codes and Inverter LED Flash Codes**

**NOTE** – System fault and lockout codes take precedence over system status codes (cooling, heating operating percentages or defrost/dehumidification). Only the latest active fault or lockout codes are displayed (if present). If no fault or lockout codes are active, then system status codes are displayed. Alert codes are also displayed on the S40 thermostat.

Alert Codes	Inverter Code	Inverter LED Flash Code (number of flashes)		Priority	Alarm Description	Possible Causes and Clearing Alarm
		Red LED	Green LED			
E183	N/A	N/A	N/A	Service Soon	Liquid Pressure Transducer Fault	Liquid pressure transducer is out of range. The signal should be between 0.5 VDC and 4.5 VDC between Blue and Black. The error code will be cleared when the proper signal is provided. Systems controlled by a conventional 24VAC heat pump thermostat will operate in stage mode.
E345	N/A	N/A	N/A	Service Urgent	Heat Pump or Air Conditioner Alert Code - The "O" relay on the outdoor board has failed.	Either the pilot relay contacts did not close, the relay coil did not energize the circuit that confirms this operational sequence is not sensing properly.
E409	N/A	N/A	N/A	Service Soon	Outdoor control secondary voltage is 18VAC or less.	Secondary voltage is below 18VAC. After 10 minutes, operation is discontinued. Check the indoor line voltage and transformer output voltage. The alarm clears after the voltage is higher than 20VAC for 2 seconds or after a power reset.
E410	N/A	N/A	N/A	Service Soon	The outdoor unit cycled off due to low suction pressure.	Unit pressure is below the lower limit. The system is shut down. The suction pressure transducer emulates a low pressure switch, the unit does not have a low pressure switch. The cut-out is set at 35 PSIG and the cut-in set at 80 PSIG. Confirm that the system is properly charged with refrigerant. Check TXV, indoor unit blower motor, dirty filters or clogged refrigerant filter. Confirm that the evaporator coil is clean. The alarm clears after the pressure rises above 90 PSIG.
E411	N/A	N/A	N/A	Service Urgent	The low pressure fault has occurred 5 times within one hour. As a result, the outdoor unit is locked out.	Low pressure fault error count reached 5 strikes. The low pressure cut-out is at 35PSIG and resets at 80PSIG. Confirm that the system is properly charged with refrigerant. Check for clogged TXV, blockage to indoor unit blower motor, dirty filters or clogged refrigerant filter. Confirm that the evaporator coil is clean. The alarm clears after a power reset.
E412	N/A	N/A	N/A	Information Only - Dealer	The outdoor unit high pressure switch has opened.	Unit pressure is above the upper limit. System is shut down. The high pressure switch opens at 590PSIG and closes at 418PSIG. Confirm that the system is properly charged with refrigerant. Check for clogged TXV, blockage to indoor unit blower motor, clogged refrigerant filter. Confirm that the outdoor unit is clean. The alarm clears after the pressure switch closes or a power reset.  For heating, indoor CFM may be set too low. For zoning system, zone CFM may be set too low.
E413	N/A	N/A	N/A	Service Urgent	The high pressure switch has opened 5 times within one hour. As a result, the outdoor unit is locked out.	Open high pressure switch error count reached 5 strikes. System is shut down. The high pressure switch for R454B opens at 590PSIG and closes at 418PSIG. Confirm that the system is properly charged with refrigerant. Check condenser fan motor, for clogged TXV, for blockage to indoor unit blower motor, for stuck reversing valve or clogged refrigerant filter. Confirm that the outdoor unit is clean. The alarm clears after a power reset.  For heating, indoor CFM may be set too low. For zoning system, zone CFM may be set too low.
E416	N/A	N/A	N/A	Service Soon/ Service Urgent	The outdoor coil sensor has malfunctioned.	EL19KPV has a fixed 10K ohm resistor installed on the harness connector between pins 5 and 6. Check connections on pins 5 6 and check for resistance of 10K ohms. Error code will occur on open or shorted circuit
E422	N/A	N/A	N/A	Service Soon	Compressor top cap switch exceeding thermal limit.	The top of the compressor is hot. Refrigerant charge may be low, or low mass flow of refrigerant. Check TXV, clogged filter drier, condenser fan motor, indoor blower motor, confirm indoor coil is clean.
E423	40	4 flashes	OFF	Service Soon/ Service Urgent	The inverter has detected a circuit problem.	Control locks out after 10 strikes within an hour. To clear, disconnect power to the indoor unit (24VAC power source to the outdoor control) which will power off the outdoor control and will open the outdoor unit contactor, which interrupts power to the inverter and then re-apply power.
E424	N/A	N/A	N/A	Service Soon	The liquid line temperature sensor has malfunctioned.	Check connections between pin 3 and 4 of the four pin liquid/ suction temperature plug on the bottom left corner of the control. Check resistance of resistor. Nominal 10K Ohms at 77F. Error code occurs if sensor is open or shorted.
E425	N/A	N/A	N/A	Information Only - Lennox	Outdoor control has increased minimum compressor speed to allow for proper oil return due to low ambient temperature. NOTE - Minimum speed adjustments begin at 45°F and increase to 100% minimum at 17°F.	Outdoor ambient temperature is below system limit. Control attempts to run at lowest allowed compressor speed to allow for proper oil return. Automatically clears when outdoor ambient temperature rises above limit for more than 5 minutes.

**TABLE 7. Outdoor Control 7-Segment Display Alert Codes and Inverter LED Flash Codes**

**NOTE** – System fault and lockout codes take precedence over system status codes (cooling, heating operating percentages or defrost/dehumidification). Only the latest active fault or lockout codes are displayed (if present). If no fault or lockout codes are active, then system status codes are displayed. Alert codes are also displayed on the S40 thermostat.

Alert Codes	Inverter Code	Inverter LED Flash Code (number of flashes)		Priority	Alarm Description	Possible Causes and Clearing Alarm
		Red LED	Green LED			
E427	21	2 flashes	1 flash	Service Soon/ Service Urgent	The inverter has detected a DC peak fault condition. If condition (55A or higher) is detected, outdoor unit compressor and fan stop. Anti-short cycle is initiated. If peak current (55A or higher) occurs 10 times within an hour, system is locked out. Indicates high pressure, condenser fan failure, locked compressor rotor or overcharge. To clear, disconnect power to the indoor unit (24VAC power source to the outdoor control) which will power off the outdoor control and will open the outdoor unit contactor, which interrupts power to the inverter and then re-apply power..	
E428	22	2 flashes	2 flashes	Service Soon/ Service Urgent	The inverter has detected a high main input current condition.	If condition is detected, is detected, outdoor unit compressor and fan stop. Antishort cycle is initiated. If condition occurs 5 times within an hour, the unitary control will cycle the contactor to prevent the unit from locking out. Indicates high pressure, condenser fan failure or overcharge.  To clear, disconnect power to the indoor unit (24VAC power source to the outdoor control) which will power off the outdoor control and will open the outdoor unit contactor, which interrupts power to the inverter and then re-apply power.
E429	23	2 flashes	3 flashes	Service Soon/ Service Urgent	On a call for compressor operation, if DC link power in inverter does not rise above 180 VDC for 2 and 3 ton models, 250 VDC for 4 and 5 ton models, within 30 seconds, the control will display a moderate code. If condition is detected, outdoor unit will stop (Compressor and fan). Antishort cycles is initiated. If condition occurs 10 times within a 60 minute rolling time period, system will lock out and display a critical code.	<b>Issues:</b> (1) If DC link power in inverter does not rise above 180 VDC for 2- and 3-ton models, 250 VDC for 4- and 5-ton models, within 30 seconds, the outdoor control will display a moderate code. (2) Capacitors on inverter do not properly charge. <b>Corrective Actions:</b> (1) Check for proper main power to outdoor unit and for any loose electrical connections.
E430	26	2 flashes	6 flashes	Service Soon/ Service Urgent	Compressor start failure	If condition is detected, outdoor unit compressor and fan stop. Antishort cycle is initiated. If condition occurs 10 times within an hour, system is locked out.  Indicates poor connection at compressor harness, improper winding resistance, locked compressor rotor, or flooded compressor.  To clear, disconnect power to the indoor unit (24VAC power source to the outdoor control) which will power off the outdoor control and will open the outdoor unit contactor, which interrupts power to the inverter and then re-apply power.
E431	27	2 flashes	7 flashes	Service Soon/ Service Urgent	Error occurs when PFC detects an over-current condition of 100A, the control will display a moderate code. If condition is detected, outdoor unit will stop (Compressor and fan). Anti-short cycle is initiated. Inverter is unavailable to communicate with the outdoor control for 3 minutes. If condition occurs 10 times within a 60 minute rolling time period, system will lock out and display a critical code.	<b>Issues:</b> (1) Indicates power interruption, brownout, poor electrical connection or loose inverter input wire. (2) System testing was set up and code was generated when the reversing valve is de-energized coming out of defrost (code appears with or without 30 compressor delay). <b>Corrective Actions:</b> (1) Check for proper main power to outdoor unit and for any loose electrical connections. (2) To clear, disconnect power to the indoor unit (24VAC power source to the outdoor control) which will power off the outdoor control and will open the outdoor unit contactor, which interrupts power to the inverter and then re-apply power.
E432	28	2 flashes	8 flashes	Service Soon/ Service Urgent	The inverter has detected a DC link high voltage condition	Error occurs when the DC link capacitor voltage is greater than 480VDC. If condition is detected, outdoor unit compressor and fan stop. Anti-short cycle is initiated. If condition occurs 10 times within an hour, system is locked out. System stops.  To clear, disconnect power to the indoor unit (24VAC power source to the outdoor control) which will power off the outdoor control and will open the outdoor unit contactor, which interrupts power to the inverter and then re-apply power.

**TABLE 7. Outdoor Control 7-Segment Display Alert Codes and Inverter LED Flash Codes**

**NOTE** – System fault and lockout codes take precedence over system status codes (cooling, heating operating percentages or defrost/dehumidification). Only the latest active fault or lockout codes are displayed (if present). If no fault or lockout codes are active, then system status codes are displayed. Alert codes are also displayed on the S40 thermostat.

Alert Codes	Inverter Code	Inverter LED Flash Code (number of flashes)		Priority	Alarm Description	Possible Causes and Clearing Alarm
		Red LED	Green LED			
E433	29	2 flashes	9 flashes	Service Soon/ Service Urgent	The inverter has detected a compressor over-current condition.	Error occurs when compressor peak phase current is greater than 28A. Inverter issues code 14 first and slows down to try to reduce the current. If the current remains high, outdoor unit compressor and fan stop. Anti-short cycle is initiated. If condition occurs five times within an hour, the unitary control will cycle the contactor to prevent the unit from locking out.  To clear, disconnect power to the indoor unit (24VAC power source to the outdoor control) which will power off the outdoor control and will open the outdoor unit contactor, which interrupts power to the inverter and then re-apply power.
E434	53	5 flashes	3 flashes	Service Soon/ Service Urgent	Outdoor control has lost communications with the inverter for greater than 3 minutes. Outdoor unit will stop all compressor demand. Outdoor control will attempt to establish communication multiple times and will automatically clear when the error clears. Unit will lock out after 60 minutes if communication is not established and will display a critical error code.	<b>Issues:</b> (1) Outdoor disconnect is off or outdoor power is off, when indoor power is on (source for 24VAC) (2) Loose electrical power connections (3) interruption of main power to the inverter (4) Generator powers indoor unit, but not the outdoor unit. <b>Corrective Actions:</b> (1) To reset, cycle the indoor power off (source of 24VAC to outdoor unit) and back on. This will de-energize outdoor control and inverter by cycling the contactor. (2) Make sure the disconnect is on (3) check electrical power supply connections (4) Check for proper main 230V power supply
E435	60	6 flashes	OFF	Service Soon/ Service Urgent	Inverter internal error	When this error occurs, the outdoor control cycles power to the inverter by opening the contactor for two minutes.  Check that the EEPROM is properly seated. After power is cycled to the inverter 3 times, the outdoor unit is locked out.  If problem persists, replace the inverter.
E436	62	6 flashes	2 flashes	Service Soon/ Service Urgent	Inverter heat sink temperature exceeded limit. Occurs when the heat sink temperature exceeds the inverter limit. Inverter issues code 13 first, then slows down to allow the heat sink to cool. If temperature remains high, outdoor unit stops (compressor and fan). Anti-short cycle is initiated. If condition occurs 5 times within an hour, the unitary control will cycle the contactor to prevent the unit from locking out.  To clear, disconnect power to the indoor unit (24VAC power source to the outdoor control) which will power off the outdoor control and will open the outdoor unit contactor, which interrupts power to the inverter and then re-apply power.	<b>Issue:</b> This error may occur if the outdoor fan fails to operate or the inverter heat sink is obstructed with debris.  Feedback from supplier tear down of inverter indicates that the screws that hold the inverter to the inverter board were loose causing poor contact between these two components. <b>Corrective Action:</b> Tighten screws that hold the heat sink to the inverter control board. <b>NOTE:</b> Wait five minutes to allow capacitor to discharge before checking screws.
E437	65	6 flashes	5 flashes	Service Soon/ Service Urgent	Heat sink temperature sensor fault has occurred (temperature less than 4°F or greater than 264°F after 10 minutes of operation).	Occurs when the temperature sensor detects a temperature less than 0.4°F or greater than 264°F after 10 minutes of operation. If condition is detected, outdoor unit will stop (compressor and fan). Anti-short cycle is initiated. If condition occurs 5 times within an hour, system will lock out.  To clear, disconnect power to the indoor unit (24VAC power source to the outdoor control) which will power off the outdoor control and will open the outdoor unit contactor, which interrupts power to the inverter and then re-apply power.  If problem persists, replace inverter.

**TABLE 7. Outdoor Control 7-Segment Display Alert Codes and Inverter LED Flash Codes**

**NOTE** – System fault and lockout codes take precedence over system status codes (cooling, heating operating percentages or defrost/dehumidification). Only the latest active fault or lockout codes are displayed (if present). If no fault or lockout codes are active, then system status codes are displayed. Alert codes are also displayed on the S40 thermostat.

Alert Codes	Inverter Code	Inverter LED Flash Code (number of flashes)		Priority	Alarm Description	Possible Causes and Clearing Alarm
		Red LED	Green LED			
E438	73	7 flashes	3 flashes	Service Soon/ Service Urgent	The inverter has detected a PFC over current condition. This would be caused by a high load condition, high pressure, or outdoor fan failure. Outdoor control will display the code when the inverter has the error. After 3 minutes, the inverter will reset and the compressor will turn on again. If it happens 10 times within a 60 minute rolling time period, the OD control will lock out operation of the outdoor unit and display a critical code.	<b>Issue:</b> Possible issue is system running at high pressures. Check for high pressure trips or other alert codes in room thermostat and outdoor control.  To clear, disconnect power to the indoor unit (24VAC power source to the outdoor control) which will power off the outdoor control and will open the outdoor unit contactor, which interrupts power to the inverter and then re-apply power.
E439	12	1 flash	2 flashes	Information Only - Dealer	Compressor slowdown due to high input current.	This error code is primarily for informational purposes as the inverter controls the compressor to operate within design parameters. Typically the inverter will make a minor speed reduction of 4 Hz (approximately a 5-6% speed reduction) for a brief period of time and to reduce the input current and will then resume normal operation.
E440	13	1 flash	3 flashes	Information Only - Dealer	Heat sink temperature is approaching limit. The compressor speed automatically slows to reduce heat sink temperature. The control sets indoor CFM and outdoor RPM to values according to demand percentage rather than the actual Hz. Alarm is automatically cleared.	This error code is primarily for informational purposes as the inverter controls the compressor speed to operate within design parameters. Typically the inverter will make a minor speed reduction of 4 Hz (approximately a 5-6% speed reduction) for a brief period of time and to reduce the heat sink temperature and will then resume normal operation. This may occur at high outdoor temperatures (above 110°F) for brief periods of time (3 – 4 minutes) and is normal and expected operation of the inverter controlling the compressor safely within design parameters.  The inverter finned aluminum heat sink is located on the back side of the inverter in the condenser air stream. If the alert code 440 occur frequently, especially at lower outdoor temperatures, check the heat sink for debris that may reduce heat transfer or possible obstructions that may impact air flow across the heat sink.  The inverter will begin to briefly reduce the compressor speed when the heat sink temperature rises above 167°F and will allow the inverter to resume the requested compressor demand speed once the inverter heat sink reaches 150°F. The heat sink temperature, compressor speed in Hertz and the Inverter Compressor Speed Reduction status (“On” or “Off”) notification can be viewed under the outdoor unit Diagnostics section of the thermostat dealer control center on units installed with an S40 thermostat.
E441	14	1 flash	4 flashes	Information Only - Dealer	Compressor slowdown due to high compressor current. Compressor current is approaching limit. The compressor speed automatically slows. The control sets indoor CFM and outdoor RPM to values according to demand percentage rather than the actual Hz. Alarm is automatically cleared.	This error code is primarily for informational purposes as the inverter controls the compressor to operate within design parameters. Alert code 441 typically occurs at startup as the compressor as the currently increases rapidly during startup.  The inverter will reduce the compressor speed by 4 hz and slow the compressor ramp up speed to the requested compressor demand (capacity). This is normal and expected operation of the inverter to control the compressor within design parameters. In most cases the alert code 441 does not require any additional service or diagnostic procedures.  E441 may also occur if the system is operating at high pressures.
E442	N/A	N/A	N/A	Service Urgent	The top cap switch has opened five times within one hour. As a result, the outdoor unit is locked out.	When compressor thermal protection sensor opens five times within one hour, outdoor stops working.  To clear, disconnect power to the indoor unit (24VAC power source to the outdoor control) which will power off the outdoor control and will open the outdoor unit contactor, which interrupts power to the inverter and then re-apply power.
E443	N/A	N/A	N/A	Service Urgent	Incorrect appliance unit size code selected.	Check for proper configuring of unit size codes for outdoor unit in configuration guide or in installation instructions. If replacing inverter, verify inverter model matches unit size. The alarm/fault clears after the correct match is detected following a reset. Remove the thermostat from the system while applying power and reprogramming.
E600	N/A	N/A	N/A	Information Only - Dealer	Compressor has been cycled OFF on utility load shedding.	Load shedding function: Provides a method for a local utility company to limit the maximum power level usage of the outdoor unit. The feature is activated by applying 24 volts AC power to the L and C terminals on the outdoor control.

**TABLE 7. Outdoor Control 7-Segment Display Alert Codes and Inverter LED Flash Codes**

**NOTE** – System fault and lockout codes take precedence over system status codes (cooling, heating operating percentages or defrost/dehumidification). Only the latest active fault or lockout codes are displayed (if present). If no fault or lockout codes are active, then system status codes are displayed. Alert codes are also displayed on the S40 thermostat.

Alert Codes	Inverter Code	Inverter LED Flash Code (number of flashes)		Priority	Alarm Description	Possible Causes and Clearing Alarm
		Red LED	Green LED			
E601	N/A	N/A	N/A	Information Only - Dealer	Outdoor unit has been cycled OFF on low temperature protection.	Low temperature protection: Outdoor unit will not operate when the outdoor temperature is at or below 4°F (20°C). If the unit is operating and the outdoor temperature drops below 4°F (20°C), the unit continues to operate until the room thermostat is satisfied or the outdoor temperature drops to 15°F (26°C). Outdoor unit ambient sensor provides temperature readings.

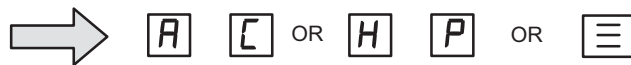
**POWER-UP / RESET:**

**7-SEGMENT POWER-UP DISPLAY STRING**

**FIRMWARE VERSION:** During initial power-up or reset, the first item displayed is the outdoor control firmware version. Example to the right shows firmware version 2.3.



**UNIT TYPE:** The next item displayed is the self discovery unit type. AC = air conditioner and HP = heat pump. If the unit type cannot be determined, three bars appear.



**UNIT NOMINAL CAPACITY:** The next item to be displayed is the self-discovery unit nominal capacity. Valid capacities are 24 for 2-ton, 36 for 3-ton, 48 for 4-ton and 60 for 5-ton units. If the unit type cannot be determined, three bars appear.



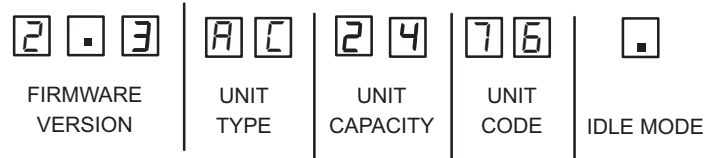
**UNIT CODE:** The next item to be displayed is the self discovery unit code. (may be a single character or two characters). If the unit code cannot be determined, three bars appear.



*(These are just examples of firmware version, unit type, unit nominal capacity and unit codes.)*

UNIT CODE	UNIT TYPE, SIZE AND MODEL	
☰	NOT PROGRAMMED	
7 6	2-TON HEAT PUMP	EL19KPV-024
7 7	3-TON HEAT PUMP	EL19KPV-036
7 8	4-TON HEAT PUMP	EL19KPV-048
7 9	5-TON HEAT PUMP	EL19KPV-060

**7-SEGMENT POWER-UP DISPLAY STRING EXAMPLE**

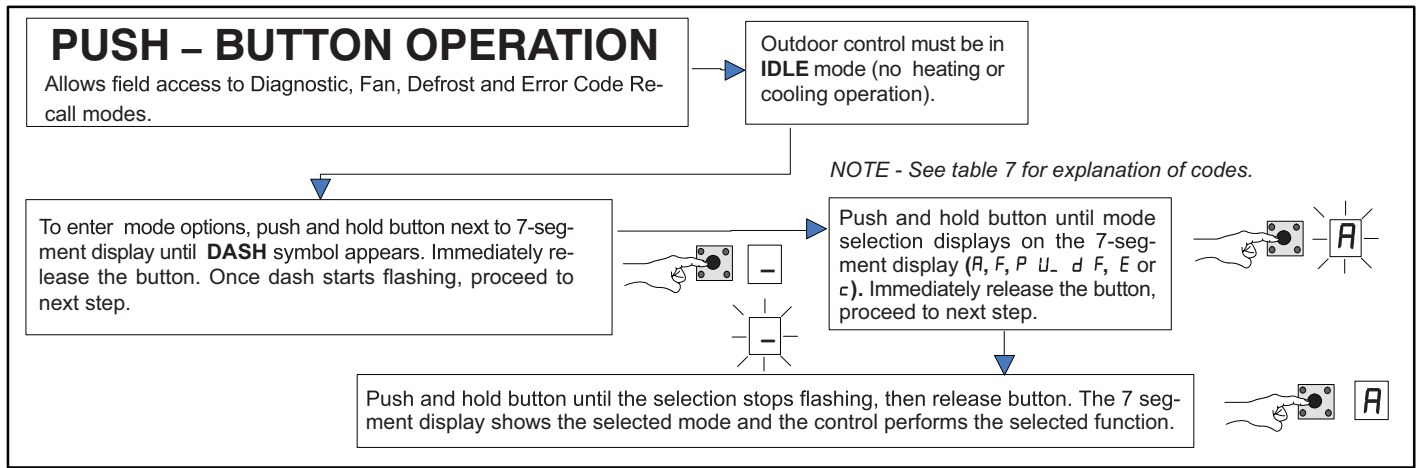


**FIGURE 18. Outdoor Control 7-Segment Unit Status Displays**

**TABLE 8. Outdoor Control 7-Segment Unit Status Displays**

Description	Example of Display
<b>Idle Mode:</b> Decimal point flashes at 1 Hz.	<b>Idle Mode:</b> Decimal point flashes at 1 Hz (0.5 second on, 0.5 second off). Display OFF.
<b>Soft Disable Mode:</b> Top and bottom horizontal line and decimal point flash at 1 Hz. If indoor or outdoor control displays Soft Disable code: 1) Confirm proper wiring between all devices (thermostat, indoor and outdoor). 2) Cycle power to the control that is displaying the Soft Disable code. 3) Put the room thermostat through Setup. 4) Go to Setup/System Devices/Thermostat/Edit/push Reset. 5) Go to Setup/System Devices/Thermostat/Edit/push Reset All. If the room thermostat detects a new device or a device that is not communicating, it sends a Soft Disable. When this occurs, Alarm 10 is activated and the room thermostat sends a Soft Disable command to the offending device on the bus (outdoor control, IFC, AHC, EIM or Damper Control Module).	<b>Soft Disable Mode:</b> Top and bottom horizontal line and decimal point flash at 1 Hz (0.5 second on, 0.5 second off). The control in Soft Disable Mode is indicated by the following: • On AHC, IFC and outdoor controls, Soft Disable Mode is indicated by flashing double horizontal lines on the 7-segment display. • On the Damper Control Module and EIM, the green LED will blink 3 seconds on and 1 second off.
<b>O.E.M. Test Mode</b>	All segments flashing at 2 Hz (unless error is detected). NOTE - Control should be replaced.
<b>Anti-Short-Cycle Delay</b>	The middle line flashes at 1 Hz for 2 seconds, followed by a 2-second display of the number of minutes left on the timer (value is rounded up: 2 min. 1 sec. is displayed as 3). If activated, the anti-short cycle delay time remaining is displayed (default is 300 sec./5 min.).
<b>Cooling Capacity:</b> Shows cooling stage C1 or C2 operating if non-communicating. Shows cooling capacity percentage i.e. C70 operating if installed with a S40 communicating thermostat. Example to the right indicates a cooling demand of 50 percent.	Cooling compressor capacity (1second on, 0.5 second off) followed by ambient temperature. Non-Communicating thermostat with second stage cooling active and ambient of 95F : C 2 pause A 9 5 repeat. S40 communicating thermostat with 70% demand and ambient of 95F: C 7 0 pause A 9 5 Repeat C 5 0 pause A 7 6
<b>Diagnostic recall:</b> Shows the last 10 stored diagnostic error codes.	If first error is E 2 5 0, second E 2 3 1 pause E 2 5 0 pause E 2 3 1 Next codes (up to 10) are shown using same method.
<b>Fault memory clears</b>	If there are no error codes stored: E pause 0 0 0. After the fault memory is cleared, the following string flashes every 0.5 seconds: 0 0 0 0 pause
<b>Active error in outdoor control Idle mode:</b> Show all active error(s) codes.	Following display string is repeated if Error E 125 and E 201 are present: E 1 2 5 pause E 2 0 1
<b>Active error in run mode:</b> Show current status and all active error(s) codes.	Following display string is repeated if Error E 440 is present while cooling demand is 80 percent: C 8 0 pause E 4 4 0
<b>Outdoor Ambient Temperature (OAT):</b> Any time OAT is within operating range, value is displayed if unit is in diagnostic and non-diagnostic modes.	Following display string is repeated if cooling is active and OAT is 104°F: C 3 5 pause A 1 0 4 pause
<b>Liquid Line Temperature (LIQ):</b> Any time LIQ is sensed in operating range, value is displayed if unit is in diagnostic mode or manually enabled for non-diagnostic modes.	Following display string is repeated if cooling is active and LIQ is 105°F: C 3 1 pause L 1 0 5 pause
<b>Charge Mode:</b> When unit is in the charge mode, Suction pressure (SPxxx), Suction Temp (Stxx.x), Superheat (SHxx.x), Liquid pressure (LPxxx), Liquid Temp (Ltxx.x) and subcooling (SCxx.x) will be scrolled on the 7-segment display	The following string is repeated: S P 1 3 5 pause S t 6 2 pause S H 1 5 pause L P 3 4 5 pause L t 9 6 pause S C 1 0 Repeat





**FIGURE 19. Push-Button Operation**

**Unit Selection Code for Outdoor Control**

If the single-character display shows three (3) horizontal lines, the unit selection code needs to be programmed. Press and hold the button until the *P U* menu option is displayed, release button. The single-character display displays the selected mode per example in figure 18 on page 47. When the desired unit selection code appears, press and hold the button until it stops flashing, then release.

Unit Code	Unit Type	Unit Model
76	2-ton heat pump	EL19KPV-024
77	3-ton heat pump	EL19KPV-036
78	4-ton heat pump	EL19KPV-048
79	5-ton heat pump	EL19KPV-060

Idle mode – System is energized with no demand – Decimal flashes at 1 Hertz > 0.5 second ON. 0.5 second OFF		
Display Symbol or Character	Display	Fan Test and Display String Option
<b>Displayed during start-up or power recycling</b>	Display string shows outdoor control firmware version <i>I L B</i> > pause > <i>R C</i> or <i>H P</i> unit > pause > unit capacity in BTUs > pause > unit code. If 3 horizontal bars are displayed during any sequence of this display string, it indicates that the specific parameter is not configured.	
.	Idle mode — decimal flashes at 1 Hertz > 0.5 second ON, 0.5 second OFF	
<i>C</i>	Indicates cooling Capacity. C1 or C2 if conventional 24VAC thermostat or demand percentage if S40 communicating thermostat is used i.e. C 9 0	
<i>F</i>	Indicates you are in the outdoor fan test mode	<b>Control must be in Idle mode:</b> To enter fan test option - <i>F</i> mode, push and hold button until solid – appears, release button. Display begins flashing. Within 10 seconds, push and hold button until required symbol <i>F</i> displays, release button. Display begins flashing. Within 10 seconds, push and hold button until display stops flashing, release button. Control will initiate outdoor fan operation. Outdoor fan cycles ON for 10 minutes at the highest speed. To exit test – Push and hold button until three horizontal bars display. Release button, outdoor fan cycles <b>OFF</b> .
<i>R</i>	<i>R</i> in the display string represents the ambient temperature in °F at the sensor on the outdoor unit.	<b>Control can be in Idle or demand mode:</b> To enter display configuration option - <i>R</i> mode, push and hold button until solid – appears, release button. Display begins flashing. Within 10 seconds, push and hold button until required symbol <i>R</i> displays, release button. Display begins flashing. Within 10 seconds, push and hold button until display stops flashing, release button. Display shows error ( <i>E</i> ) code(s) and ambient ( <i>R</i> ), outdoor coil ( <i>C</i> ) and liquid ( <i>L</i> ) temperatures in Fahrenheit. <b>NOTE</b> - If button is not pushed in the 10-second time period, the control exits the test mode. If this occurs, test mode must be repeated.

Error Code Recall Mode (NOTE – control must be in idle mode)	
<i>E</i>	To enter error code recall mode, push and hold button until solid <i>E</i> appears, then release button. Control displays up to 10 error codes stored in memory. If <i>E 0 0 0 0</i> is displayed, there are no stored error codes.
≡	To exit error code recall mode, push and hold button until solid three horizontal bars appear, then release button. Note - Error codes are not cleared.
<i>c</i>	To clear error codes stored in memory, continue to hold button while the 3 horizontal bars are displayed. Release button when solid <i>c</i> is displayed.
<i>c</i>	Push and hold for one (1) second, release button. 7-Segment displays 0 0 0 0 and exits error recall mode.

## FIELD TEST MODE OPERATION

The field test mode allows the unit to be put into diagnostic mode and allows the installer to perform multiple tests on the control / unit.

### Diagnostic Mode

Diagnostic mode is only available when the system is idle or during an active / suspended call for heating or cooling. Diagnostic mode is terminated when the exit command is given, the button is pressed and released without entering the diagnostic menu or 10 minutes has passed, whichever comes first.

When this mode is selected all installed temperature sensor valves (non-open and non-short) are shown on the 7-segment display. The following system status codes are displayed:

- Cooling
- Cooling stage or cooling percentage demand operation
- Active error codes

### Outdoor Fan Mode

Diagnostic mode is only available while the system is in idle mode. This mode can be exited with the proper command or after 10 minutes has passed.

In diagnostic mode, the control energizes the outdoor fan at the highest speed.

### **CHARGE MODE OPERATION**

To initiate the EL19KPV Charge Mode function, install the jumper across the two Charge Mode Pins (CHRG MODE) on the outdoor control. The Charge Mode can be used when charging the system with refrigerant, checking the refrigerant charge, pumping down the system and performing other service procedures that requires outdoor unit operation at 100% capacity.

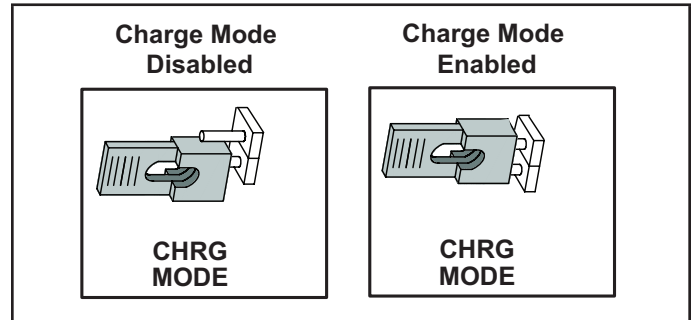
### **EL19KPV Charge Mode Operation with a S40 Communicating Thermostat**

Installing a jumper on the Charge Mode Pins will initiate compressor operation in the cooling mode and outdoor fan motor at 100% capacity and will provide a signal to the indoor unit to initiate indoor blower operation at the maximum cooling air volume. To exit the charge mode, remove the Charge Mode Jumper. The Charge Mode has a maximum time of 60 minutes and will automatically exit the charge mode after 60 minutes if the charge mode jumper is left in place.

### EL19KPV Charge Mode Operation with a Conventional 24VAC Non-Communicating Heat Pump Thermostat – Cooling Mode

On applications with a conventional 24VAC non-communicating thermostat, the charge mode jumper must be installed on the Charge Mode Pins after providing a Y1 compressor demand to the EL19KPV to initiate the Charge Mode. When using the Charge Mode in the cooling mode, the “O” must also be provided with a 24V signal to place the re-versing valve in the cool position. In the heating mode only a Y1 compressor demand is required along with the blower demand for the full cooling air volume. A cooling blower demand must also be provided to initiate blower operation on the cooling speed on the indoor unit. The compressor and outdoor fan motor will operate at 100% capacity.

To exit the charging mode, remove the Charge Mode Jumper and remove the Y1 compressor demand and indoor blower demand. The Charge Mode has a maximum time of 60 minutes and will automatically exit the charge mode after 60 minutes if the charge mode jumper is left in place.



**TABLE 9. Field Test, Diagnostic Recall and Program Menu Options**

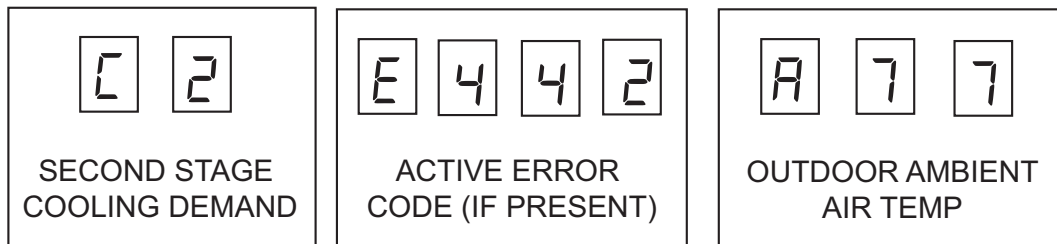
Display	Display and action (normal operation)
No Change - idle (*)	No Change - idle (*)
Solid .	Enter or exit field test and program mode.
Solid R	Puts unit in diagnostic mode. (Displays ambient temperatures and any active error codes.)
Solid c	Clears error history (**)
Solid E	Enter diagnostic recall mode. Displays up to 10 error codes in memory.
Solid F	Starts outdoor fan.
String P U	Enter unit code programming.

\*No change indicates the display will continue to show whatever is currently being displayed for normal operations.

\*\*Note once the error history is deleted it cannot be recovered. After the history is deleted, the unit will reset itself.

Display	Display and action (normal operation)
.	Idle mode — decimal flashes at 1 Hertz > 0.5 second ON, 0.5 second OFF
C	Cooling operation. Shows cooling stage C1 or C2 operating if non-communicating. Shows cooling capacity percentage i.e. C 7 0 operating if installed with a S40 communicating thermostat. Example: C 2 0 pause R 7 5
E	E in the display string represents the active error code(s) in the outdoor unit. Example: C 5 0 pause E 4 4 pause E 4 4 2 pause R 7 5 pause
R	R in the display string represents the outdoor ambient temperature in °F at the outdoor sensor on the outdoor unit. Example: C 5 0 pause R 7 5
Scrolling	When unit is in the charge mode, Suction pressure (SPxx), Suction Temp (Stxx.x), Superheat (SHxx.x), Liquid pressure (LPxx), Liquid Temp (Ltxx.x) and subcooling (SCxx.x) will be scrolled on the 7-segment display. Example: S P 1 3 5 pause S t 6 2 pause S H 1 5 pause L P 3 4 5 pause L t 9 6 pause S C 1 0 Repeat

### TYPICAL 7-SEGMENT ACTIVE COOLING DEMAND DISPLAY STRING

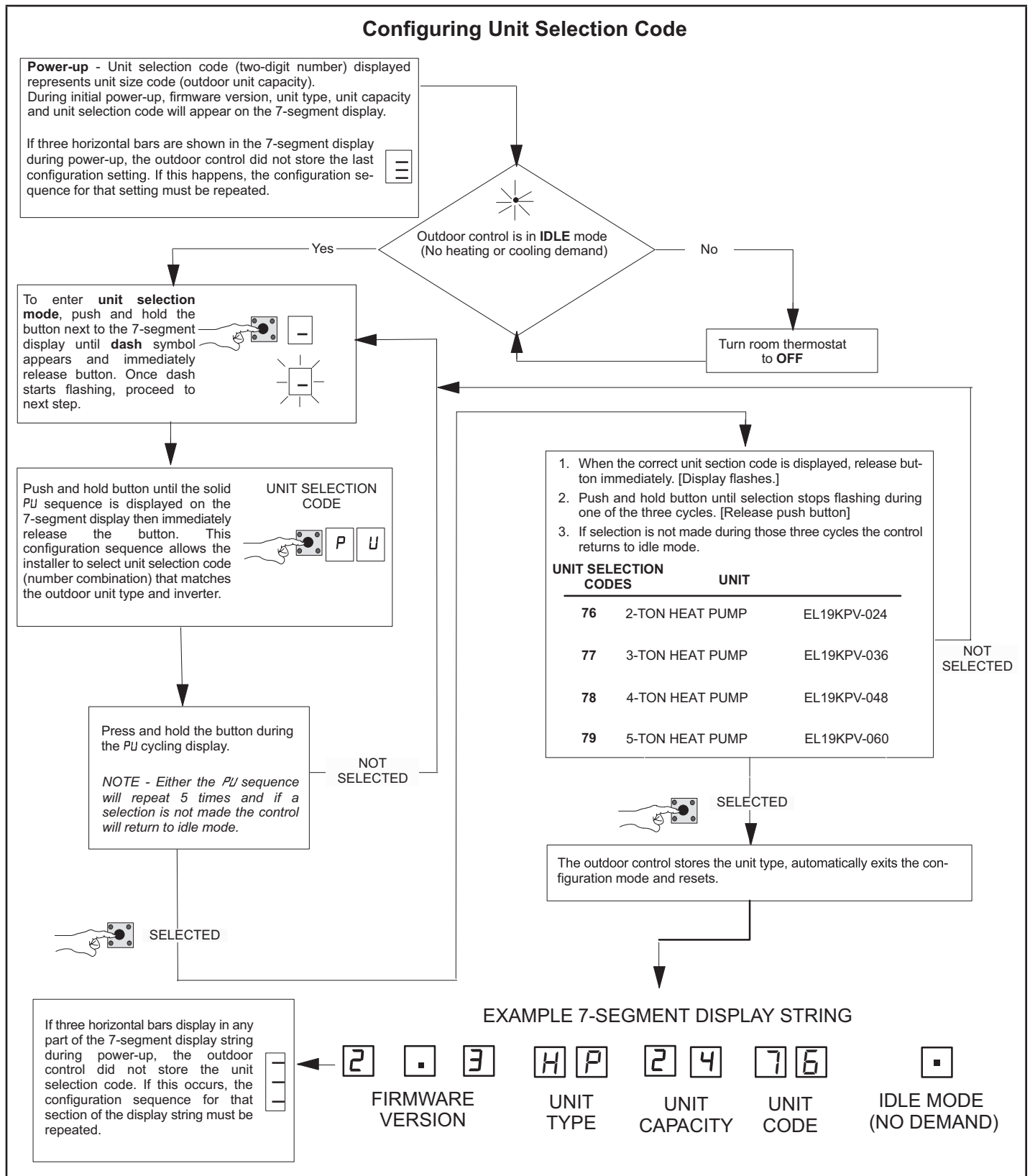


BY DEFAULT, COOLING DEMAND, ACTIVE ERROR CODES AND OUTDOOR AMBIENT TEMPERATURE ARE DISPLAYED.

**FIGURE 20. Typical 7-Segment Demand Display String**

## Configuring Unit

When installing a replacement outdoor control, the unit selection code may have to be manually assigned using the 7-segment display and push button on the control. The unit code sets unit type, capacity and outdoor fan profile.



**FIGURE 21. Configuring Unit Selection Code**

## Reconfiguring Outdoor Control Using S40 Thermostat

Reconfiguring only applies to EL19KPV units installed as a fully communicating system with an S40 thermostat and communicating indoor unit.

If any component of the HVAC system is changed, e.g. replacing an outdoor sensor, reconfiguring the system is required. To begin reconfiguring a system, select the Set-up tab.

## System Overview

Refer to the applicable Thermostat Installer Setup Guide for configuration procedures.

The outdoor control provides the following functions:

- Internal switching of outputs.
- Compressor anti-short-cycle delay (adjustable through the thermostat interface).
- Five-strike lockout function.
- High Pressure protection using the High Pressure Switch (S4) and Low Suction Pressure protection using the the suction pressure transducer to emulate the Low Pressure Switch.
- Ambient (RT13), liquid line (RT36) and suction line (RT41) temperatures for monitoring and protection.
- Suction Pressure Transducer (A168) and Liquid Pressure Transducer (A188) for monitoring and control.

### COMPRESSOR PROTECTION – FIVE-STRIKE LOCK-OUT

The five-strike lockout function is designed to protect the compressor from damage. The five-strike feature is used for both high (S4) and low (S87) pressure switches.

#### Resetting Five-Strike Lockout

Once the condition has been rectified, power to the outdoor control R terminal must be cycled OFF.

## Diagnostic Information - Installations with S40 Thermostat

The following diagnostic information is available through the thermostat's user interface. Refer to the applicable Installer System Setup Guide.

- Compressor anti-short-cycle delay timer status
- Cooling stage or cooling rate
- Compressor shift delay timer status

- High pressure switch status
- Low suction pressure protection status
- Suction pressure
- Liquid pressure
- Target Frost Accumulation Time
- Frost Accumulation Time
- Compressor top cap switch status
- Liquid line and suction line temperature
- Outdoor ambient temperature
- Compressor active alarm
- Compressor Hz
- Inverter compressor short cycle
- Heat sink temperature

## Installer Test - Installations with S40 Thermostat

Verify the proper operation of the system by running the Installer Test feature through the thermostat interface. Refer to the applicable Installer System Setup Guide.

### COMPRESSOR SHORT CYCLING DELAY

The outdoor control protects the compressor from:

- Short cycling (five minutes) during initial power-up.
- Interruption in power to the unit.
- Pressure or sensor trips.
- Delay after demand is removed.

The delay is set by default for 300 seconds (five minutes) but can be changed through the thermostat interface (S40 thermostat installations only).

Available settings are 60, 120, 180, 240 and 300 seconds.

### CRANKCASE HEATER (HR1)

Compressors in all units are equipped with a 40-watt bellyband- type crankcase heater. HR1 prevents liquid from accumulating in the compressor. HR1 is controlled by the crankcase heater thermostat.

### CRANKCASE HEATER THERMOSTAT (S40)

Thermostat S40 controls the crankcase heater in all units. S40 is located on the on the compressor shell. When the compressor shell temperature drops below 50°F, thermostat S40 closes, energizing HR1. The thermostat opens, de-energizing HR1, once liquid line temperature reaches 70°F.

## Maintenance

### Outdoor Unit

Maintenance and service must be performed by a qualified installer or service agency. At the beginning of each cooling season, the system should be checked as follows:

- 1 - Clean and inspect outdoor coil (may be flushed with a water hose). Ensure power is off before cleaning.
- 2 - Outdoor unit fan motor is factory-lubricated and sealed. No further lubrication is needed.
- 3 - Visually inspect all connecting lines, joints and coils for evidence of oil leaks.
- 4 - Check all wiring for loose connections.
- 5 - Check for correct voltage at unit (unit operating).
- 6 - Check amp draw on outdoor fan motor.
- 7 - Inspect drain holes in coil compartment base and clean if necessary.

**NOTE** - *If insufficient heating or cooling occurs, the unit should be gauged and refrigerant charge should be checked.*

### Outdoor Coil

It may be necessary to flush the outdoor coil more frequently if it is exposed to substances which are corrosive or which block airflow across the coil (e.g., pet urine, cottonwood seeds, fertilizers, fluids that may contain high levels of corrosive chemicals such as salts).

- Outdoor Coil — The outdoor coil may be flushed with a water hose.
- Outdoor Coil (Coastal Area) — Moist air in ocean locations can carry salt, which is corrosive to most metal. Units that are located near the ocean require frequent inspections and maintenance. These inspections will determine the necessary need to wash the unit including the outdoor coil. Consult your installing contractor for proper intervals/procedures for your geographic area or service contract.

### Indoor Unit

- 1 - Clean or change filters.
- 2 - Lennox blower motors are factory-lubricated and permanently sealed. No more lubrication is needed.
- 3 - Adjust blower speed for cooling. Measure the pressure drop over the coil to determine the correct blower CFM. Refer to the unit information service manual for pressure drop tables and procedure.
- 4 - Check all wiring for loose connections.
- 5 - Check for correct voltage at unit. (blower operating)
- 6 - Check amp draw on blower motor.

### Indoor Coil

- 1 - Clean coil if necessary.
- 2 - Check connecting lines, joints and coil for evidence of oil leaks.
- 3 - Check condensate line and clean if necessary.

# Unit Wiring Diagrams

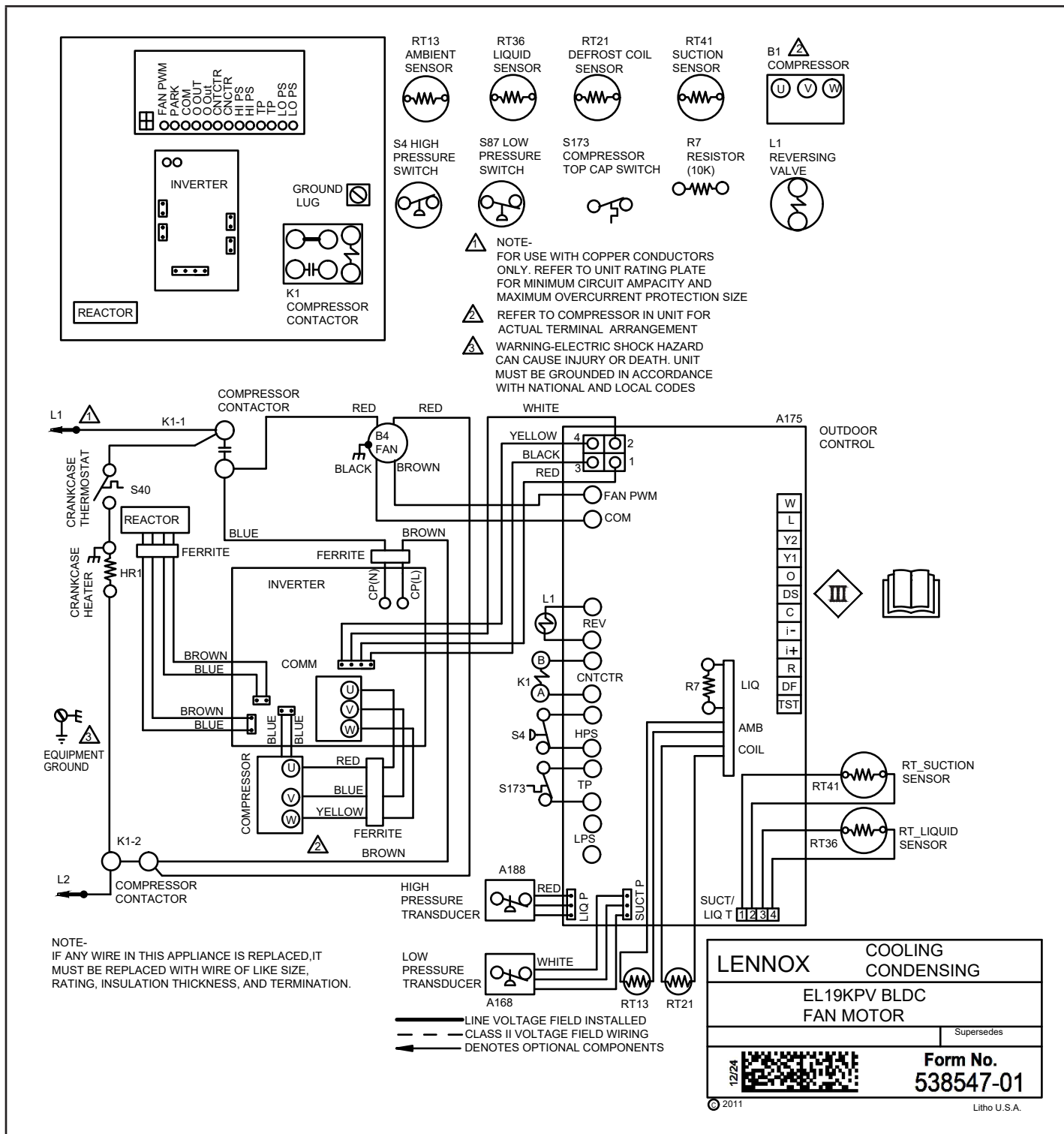


FIGURE 22. Typical Unit Wiring (EL19KPV)

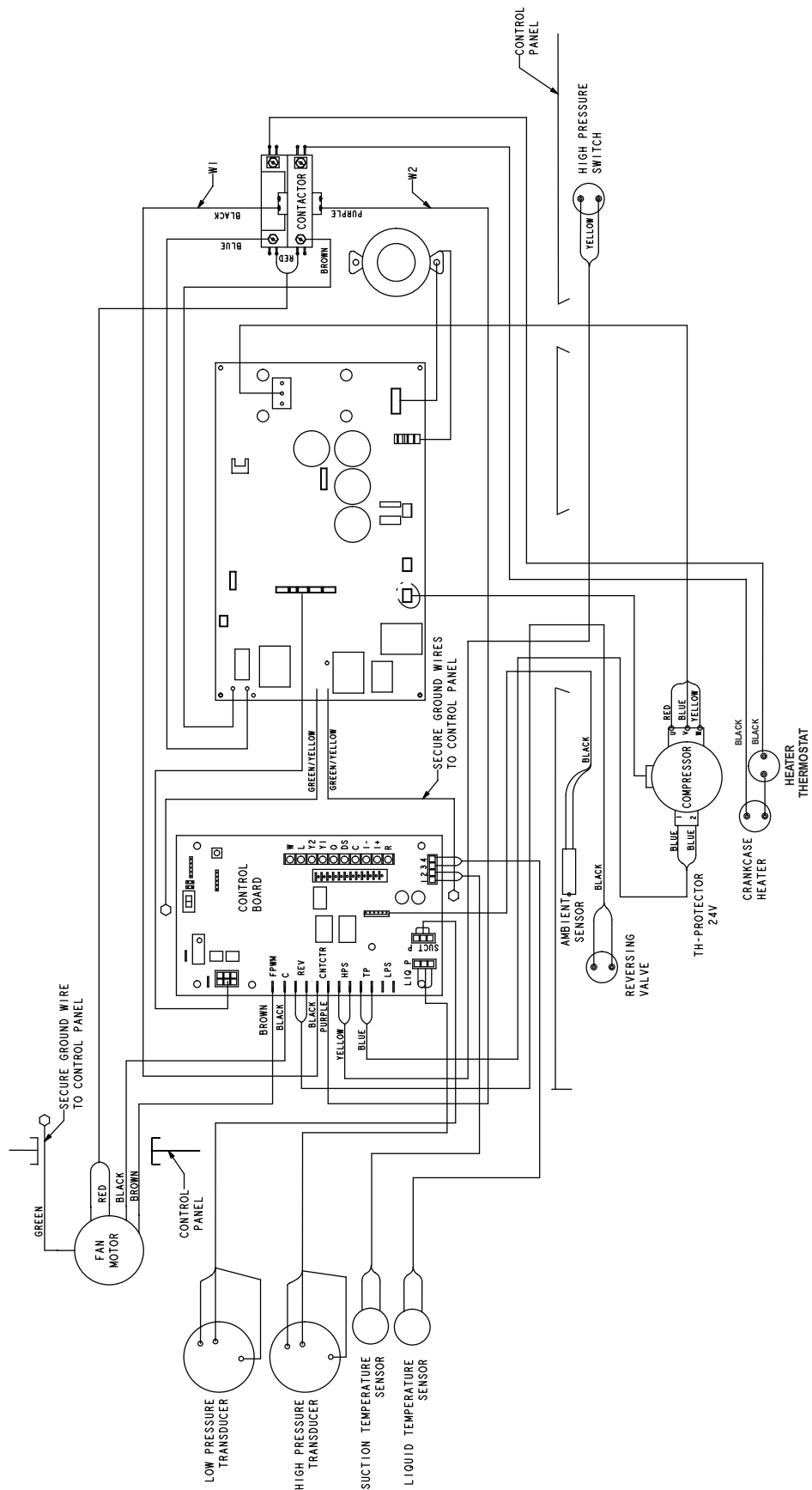


FIGURE 23. Typical Factory Wiring (EL19KPV-024, -036)



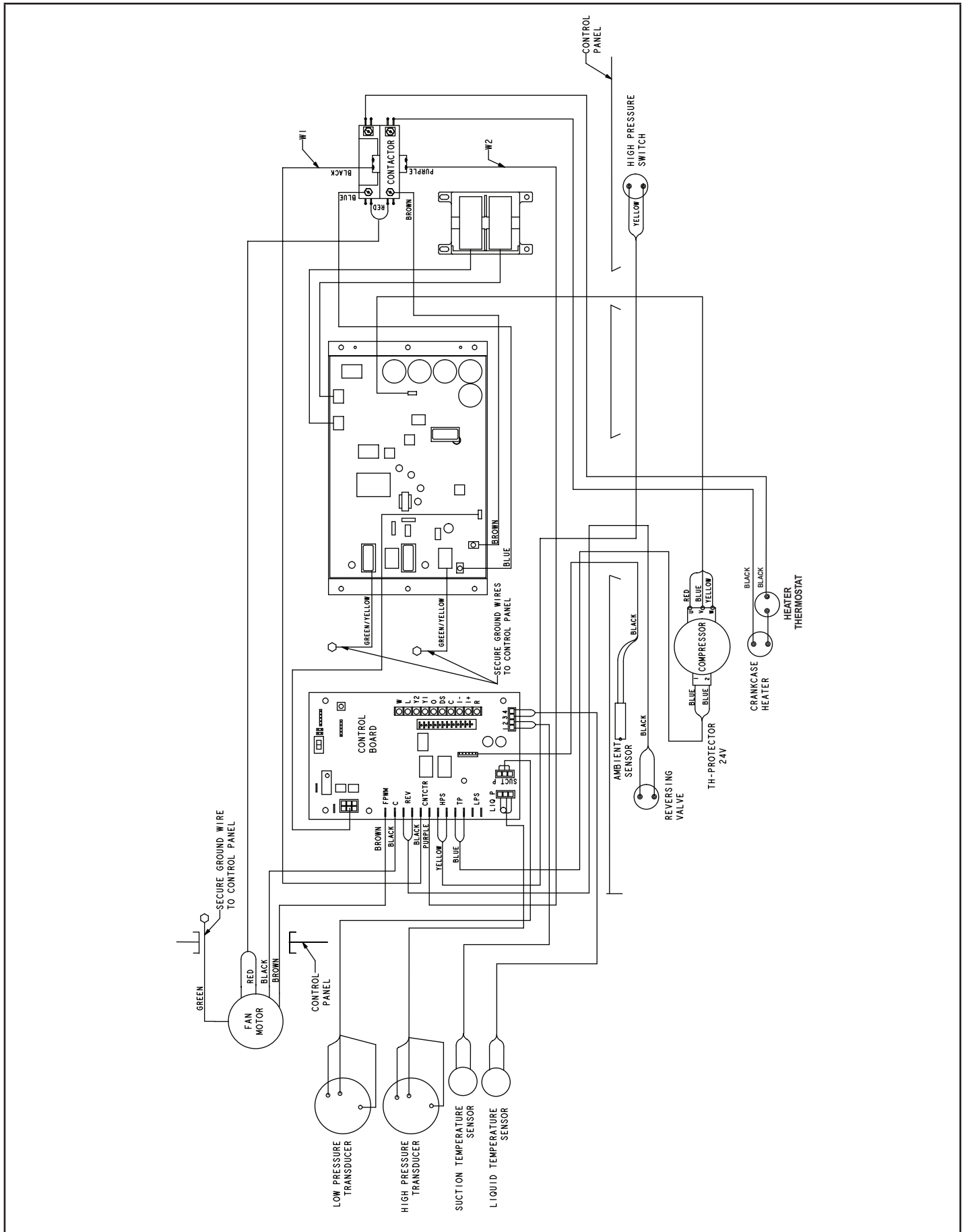
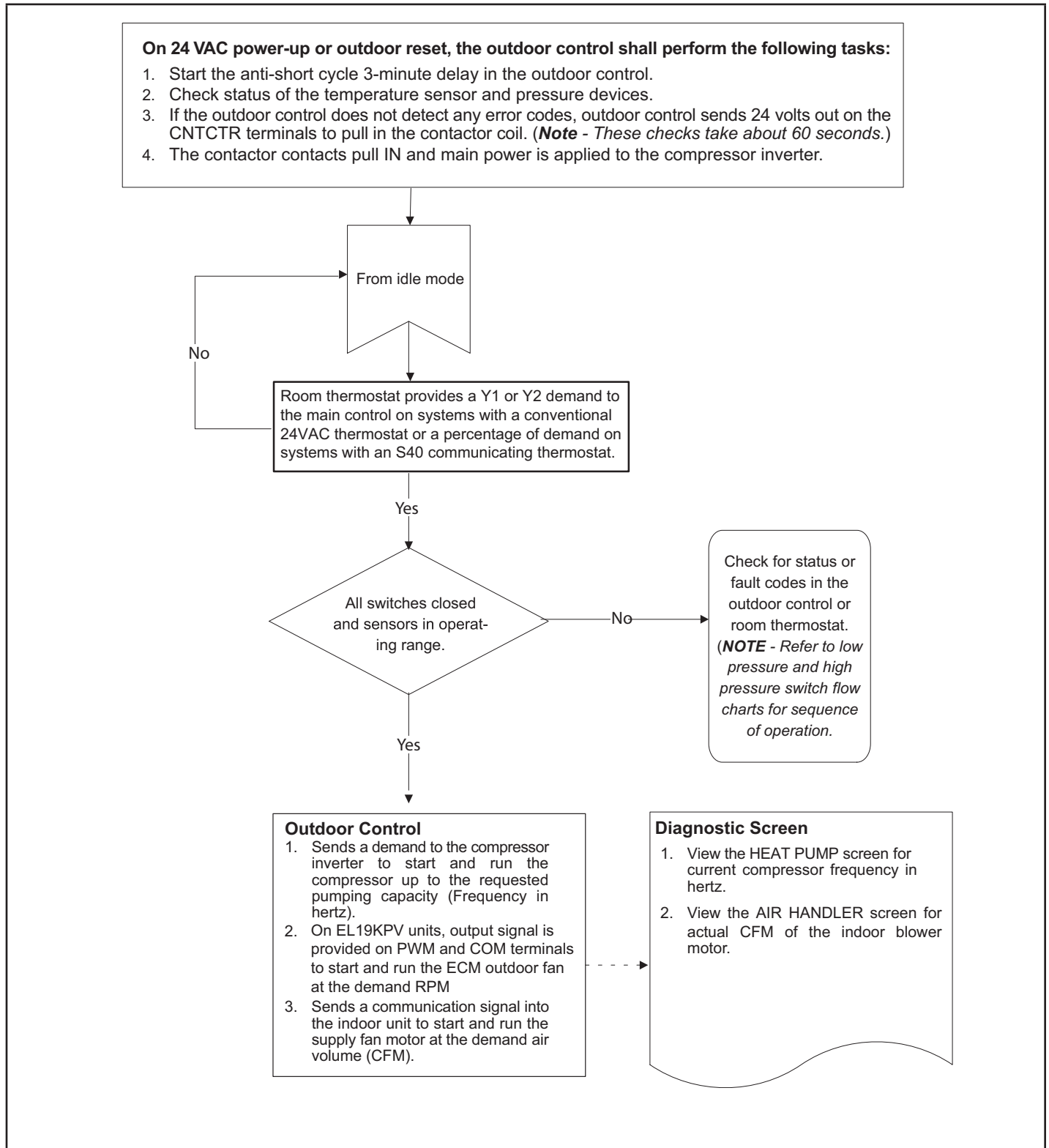


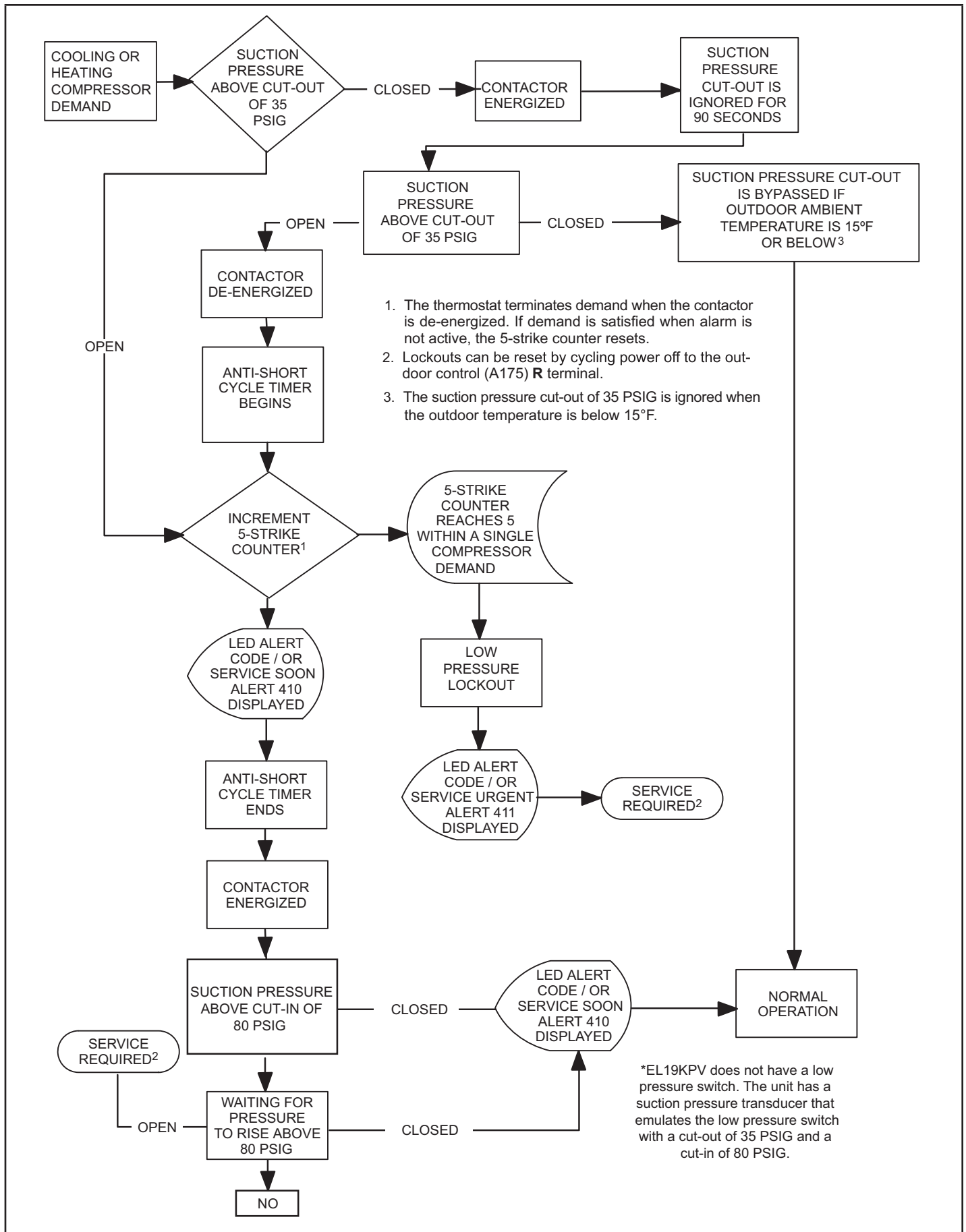
FIGURE 24. Typical Factory Wiring (EL19KPV-048, -060)

## Unit Sequence of Operation

The following figures illustrate the overall unit sequence of operation along with the operation of various pressure switches and temperature sensors. The figures also illustrate the use of the compressor anti-short-cycle function in relation to unit Status, unit Fault and lockout LED Codes and unit system operation interactions.



**FIGURE 25. 24 Volt Power-Up or Outdoor Reset**



**FIGURE 26. Low Pressure Switch Emulated by Suction Pressure Transducer – Sequence of Operation**

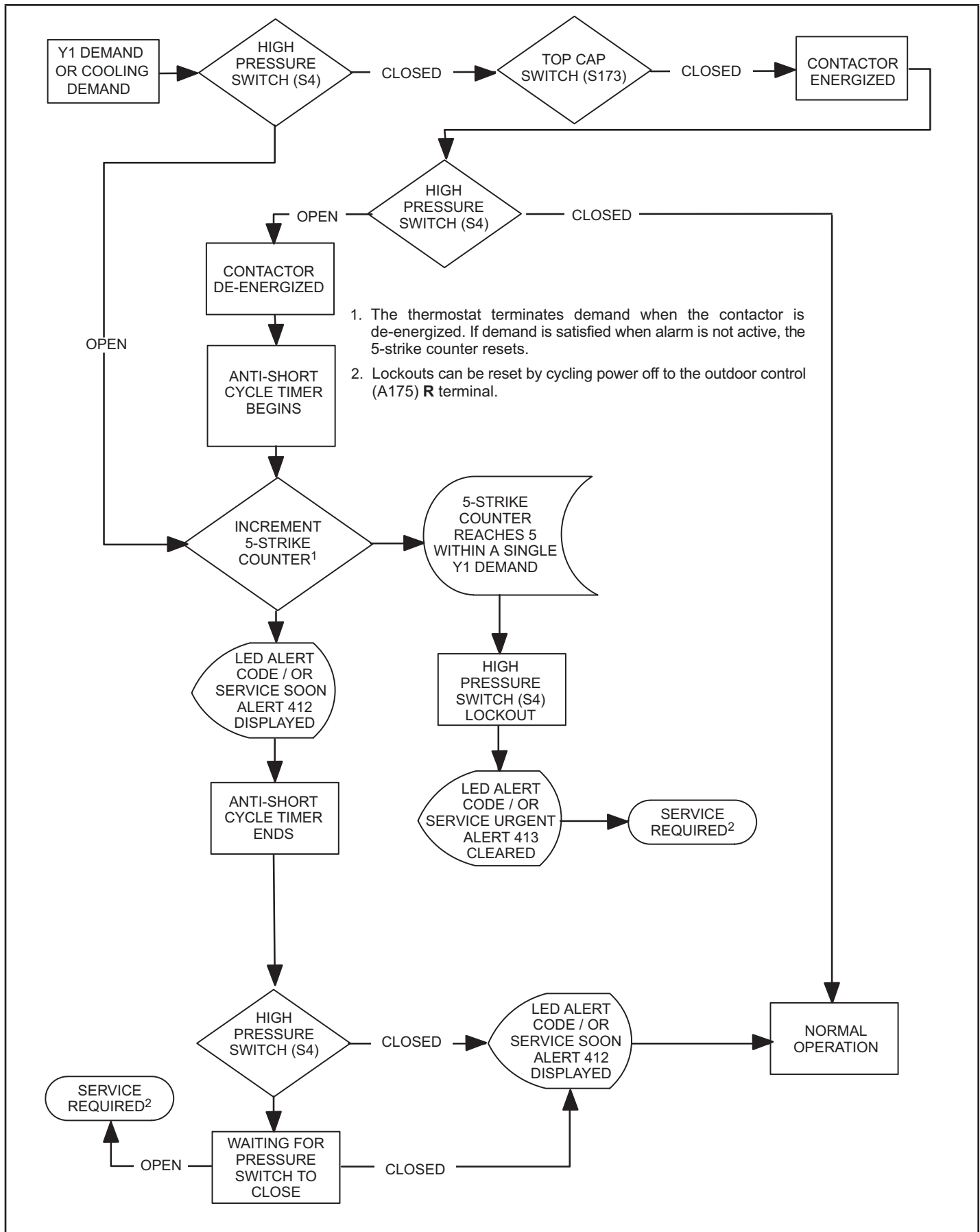
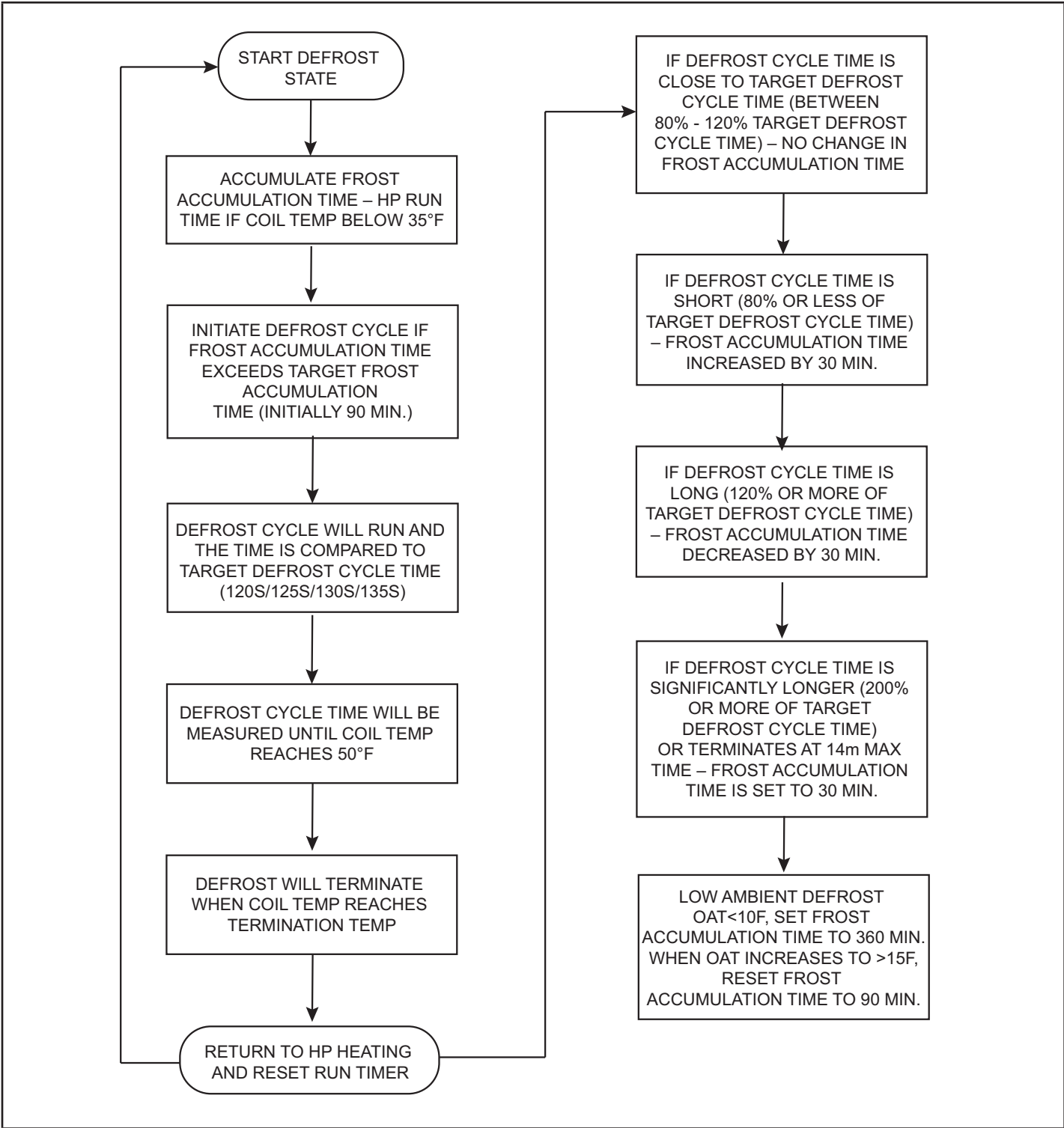


FIGURE 27. High Pressure Switch (S4) Sequence of Operation (All Versions)



**FIGURE 28. Demand Defrost Cycle – Sequence of Operation**

**Component Testing Table of Contents**

Verifying Suction Liquid Pressure Transducer Operation .63	Top Cap Switch Operation.....71
Compressor Operation, Checkout and Status / Error Codes .....65	Reactor Operations .....72
Crankcase Heater, Checkout and Status / Error Codes .67	Outdoor Fan Operation.....72
Compressor Sound Cover.....70	Outdoor Control Operation ..... 72
Suction Line Filter Drier.....70	Unit Sensor Operations ..... 78
	DC Inverter Control Operation..... 81

**Verifying High Pressure Switch and Low Pressure Protection Operation**

**OPERATION:**

The unit's pressure switch (HPS - S4) is wired into the the control HPS terminal.

NOTE – The EL19KPV does not have a low pressure switch and LPS terminals are not jumpered. The unit has a suction pressure transducer that emulates the low pressure switch with a cut-out of 35 PSIG and a cut-in of 80 PSIG. This provide the same protection as a tradition low pressure switch. If the event the suction pressure transducer fails, back up protection is provided by the suction temperature sensor and will open at 25F.

**Low Suction Pressure Protection (LPS)** – See figure 25 for low suction pressure protection sequence of operation.

**High Pressure Switch (HPS)** – See figure 26 for high pressure switch sequence of operation.

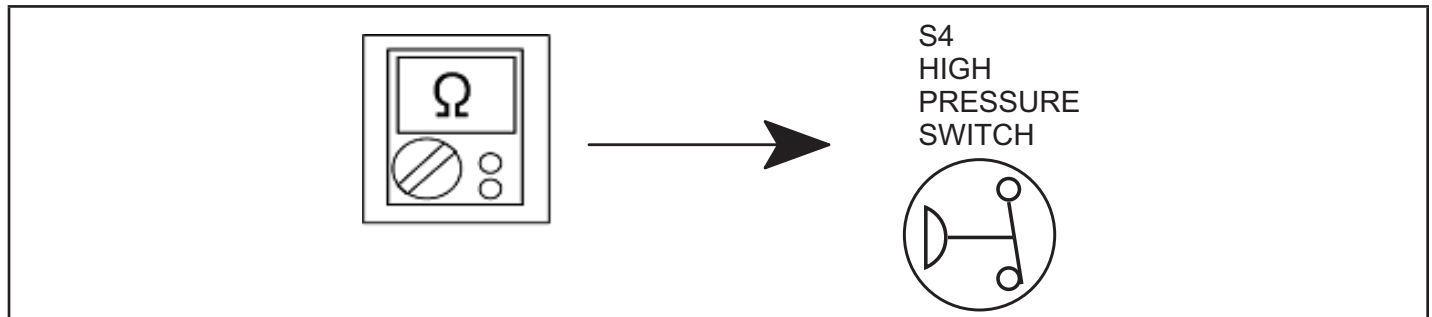
**Pressure Switch Event Settings**

The following pressures are the auto-reset event value triggers for low and high pressure thresholds:

- High Pressure (auto-reset) - trip at 590 psig; reset at 418.
- Low Pressure (auto-reset) – trip at 25 psig; reset at 40.

**CHECKOUT – S4 High Pressure Switch**

Using a multimeter set to ohms with the terminals disconnected from the control board, check the resistance between the two terminals of the pressure switch. If the resistance reading is 0 ohms, the switch is closed.



**FIGURE 29. Verifying High Pressure Switch Operation**

## Verifying Suction Pressure Transducer Operation

Using a multimeter set to VDC with the Suction Pressure Transducer connected to the "Suct P" 3-pin connector on the control board. Pin 1 (Red wire +5VDC) to Pin 3 (Black wire - GND) should read 5 VDC continuous. Pin 2 (Blue wire output from transducer) to Pin 3 (Black - GND) should read 0.5 to 4.5 VDC and will vary depending on suction pressure measured. See Table 10.

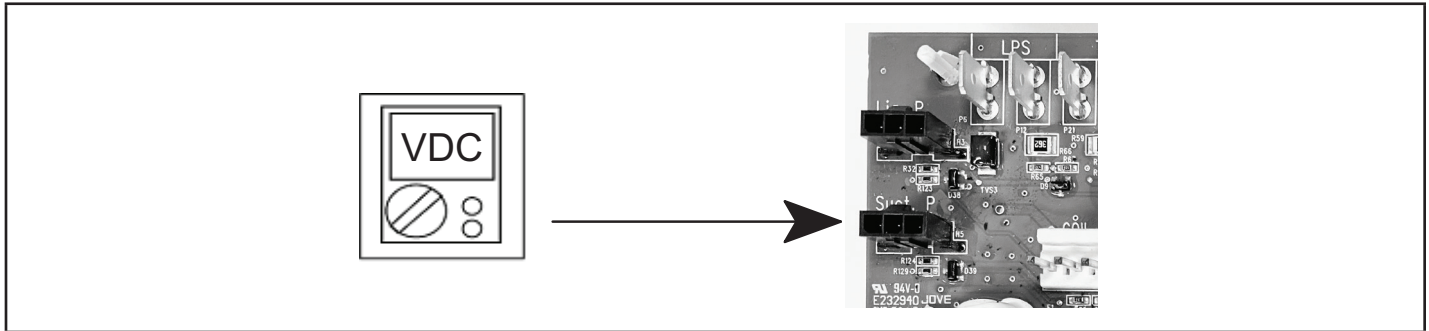


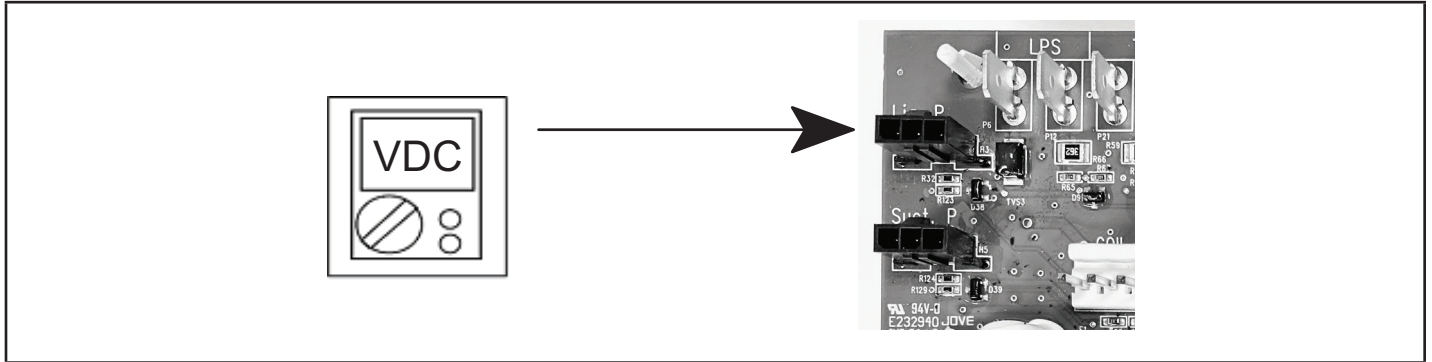
FIGURE 30. Suction Pressure Transducer Voltage

TABLE 10. Suction Pressure Transducer Output Voltage

Suction Pressure (PSIG)	DC Voltage Output (Pin 2 to Pin 3)	Suction Pressure (PSIG)	DC Voltage Output (Pin 2 to Pin 3)
0	0.49	110	2.69
10	0.69	120	2.89
20	0.89	130	3.09
30	1.09	140	3.29
40	1.29	150	3.49
50	1.49	160	3.69
60	1.69	170	3.89
70	1.89	180	4.09
80	2.09	190	4.29
90	2.29	200	4.49
100	2.49	210	4.50

## Verifying Liquid Pressure Transducer Operation

Using a multimeter set to VDC with the Liquid Pressure Transducer connected to the "Liq P" 3-pin connector on the control board. Pin 1 (Red wire +5VDC) to Pin 3 (Black wire - GND) should read 5 VDC continuous. Pin 2 (Blue wire output from transducer) to Pin 3 (Black - GND) should read 0.5 to 4.5 VDC and will vary depending on liquid~ pressure measured. See Table 11.



**FIGURE 31. Liquid Pressure Transducer Voltage**

**TABLE 11. Liquid Pressure Transducer Output Voltage**

Liquid Pressure (PSIG)	DC Voltage Output (Pin 2 to Pin 3)	Liquid Pressure (PSIG)	DC Voltage Output (Pin 2 to Pin 3)	Liquid Pressure (PSIG)	DC Voltage Output (Pin 2 to Pin 3)
0	0.50	210	1.90	420	3.30
10	0.57	220	1.97	430	3.37
20	0.63	230	2.03	440	3.43
30	0.70	240	2.10	450	3.50
40	0.77	250	2.17	460	3.57
50	0.83	260	2.23	470	3.63
60	0.90	270	2.30	480	3.70
70	0.97	280	2.37	490	3.77
80	1.03	290	2.43	500	3.83
90	1.10	300	2.50	510	3.90
100	1.17	310	2.57	520	3.97
110	1.23	320	2.63	530	4.03
120	1.30	330	2.70	540	4.10
130	1.37	340	2.77	550	4.17
140	1.43	350	2.83	560	4.23
150	1.50	360	2.90	570	4.30
160	1.57	370	2.97	580	4.37
170	1.63	380	3.03	590	4.43
180	1.70	390	3.10	600	4.50
190	1.77	400	3.17		
200	1.83	410	3.23		



## High Pressure Switch and Low Pressure Protection Errors

**TABLE 12. Outdoor Control 7-Segment Display Alert Codes**

*System fault and lockout codes take precedence over system status codes (cooling, heating operating percentages or defrost/dehumidification). Only the latest active fault or lockout codes are displayed (if present). If no fault or lockout codes are active, then system status codes are displayed. Alert codes are also displayed on the communicating thermostat.*

Alert Codes	Priority	Alarm Description	Possible Causes and Clearing Alarm
E 410	Service Soon	The outdoor unit cycled off due to low pressure switch opening.	Unit pressure is below the lower limit. The system is shutdown. The low pressure switch closes above 80PSIG and opens below 35PSIG. Confirm that the system is properly charged with refrigerant. Check TXV, indoor unit blower motor, dirty filters or clogged refrigerant filter. Confirm that the evaporator coil is clean. The alarm clears after the pressure switch opens or after a power reset.
E 411	Service Urgent	The low pressure switch has opened 5 times within one hour. As a result, the outdoor unit is locked out.	Low pressure switch error count reached 5 strikes. The low pressure switch for R454B opens at 35PSIG and resets at 80PSIG. Confirm that the system is properly charged with refrigerant. Check for clogged TXV, blockage to indoor unit blower motor, dirty filters or clogged refrigerant filter. Confirm that the evaporator coil is clean. The alarm clears after a power reset.
E 412	Service Soon	The outdoor unit high pressure switch has opened.	Unit pressure is above the upper limit. System is shut down. The high pressure switch opens at 590PSIG and closes at 418PSIG. Confirm that the system is properly charged with refrigerant. Check for clogged TXV, blockage to indoor unit blower motor, clogged refrigerant filter. Confirm that the outdoor unit is clean. The alarm clears after the pressure switch closes or a power reset. For heating, indoor CFM may be set too low. For zoning system, zone CFM may be set too low.
E 413	Service Urgent	The high pressure switch has opened 5 times within one hour. As a result, the outdoor unit is locked out.	Open high pressure switch error count reached 5 strikes. System is shut down. The high pressure switch for R454B will open at 590PSIG and close at 418PSIG. Confirm that the system is properly charged with refrigerant. Check condenser fan motor, clogged TXV, blockage to indoor unit blower motor, stuck reversing valve or clogged refrigerant filter. Confirm that the outdoor unit is clean. The alarm clears after indoor power reset (24VAC power source to Outdoor Control)

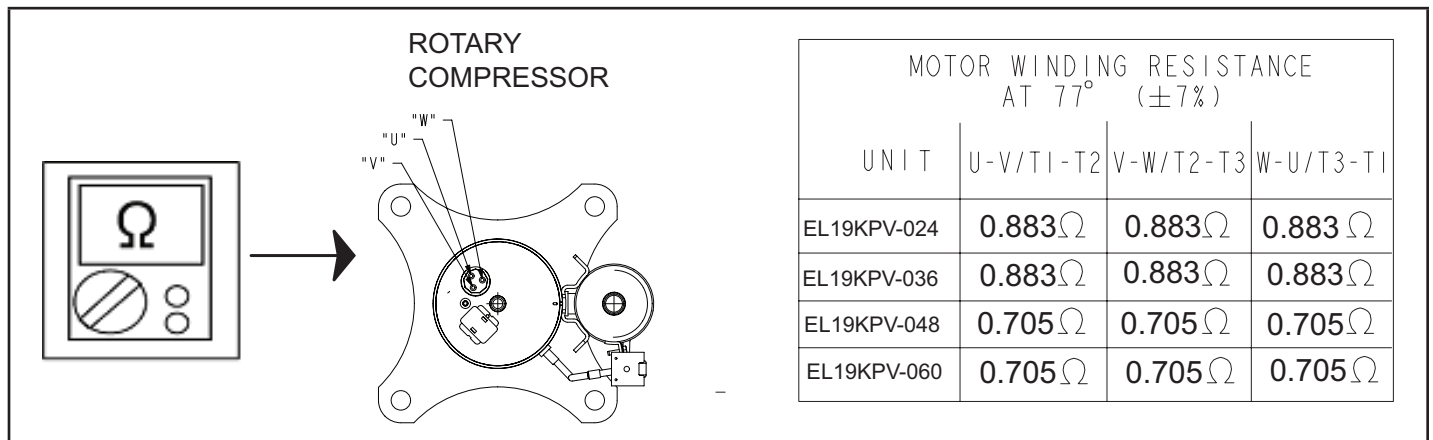
## Compressor Operation, Checkout and Status / Error Codes

### OPERATION:

The EL19KPV units use a 380VAC three phase variable capacity rotary compressor specifically designed for unitary splits system and is approved for use with R454B refrigerant. The compressor, when connected to an inverter, is capable of operating in a running frequency range from 20 hertz up to a maximum of 79 hertz. (maximum hertz is dependent on compressor size). The compressor speed is determined by thermostat demand and suction pressure when installed with a conventional 24VAC non-communicating thermostat and by thermostat demand when installed with an S40 thermostat.

### CHECKOUT:

**NOTE** - The compressor motor winding resistance is the nominal resistance at 77F. When measuring compressor motor winding resistance, the primary concern is the winding resistance between the different sets of terminals is within 10% of each other. The actual winding resistance is impacted by temperature, refrigerant and oil. Do not automatically condemn a compressor because the measured resistance is slightly higher or lower than the nominal resistance. Check for shorted/open windings and for shorts to ground during testing.



**FIGURE 32. Compressor Operation, Checkout and Status/Error Codes**

IMPORTANT: If compressor replacement is required, remove the compressor through the top of the unit. Removal through the access panel is not possible.

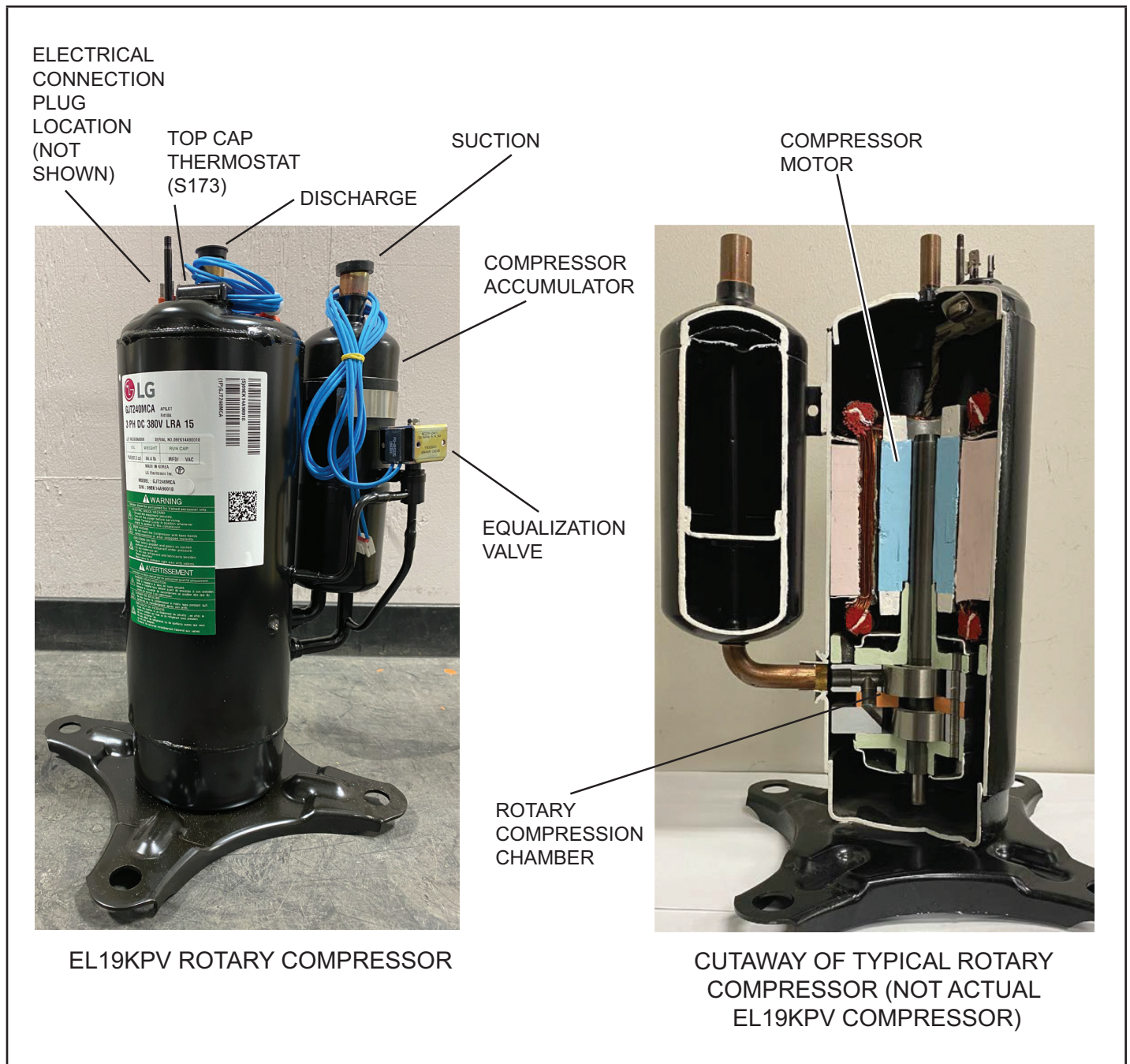


FIGURE 33. EL19KPV Rotary Compressor Detail

### Compressor Equalization Valve

The compressor equalization valve equalization solenoid equalizes the pressure across the rotary compression chamber allowing the compressor to start unloaded. The 240 VAC solenoid coil is controlled by the inverter.

The solenoid coil is powered when the compressor is off to equalize the pressure and is de-energized when the compressor is operating

## STATUS CODES:

When the compressor is running, the 7-segment display will show the compressor capacity. When the EL19KPV unit is installed with a conventional 24VAC non-communicating thermostat the display will show C 1 or C 2. When the EL19KPV unit is installed with a S40 communicating thermostat the display will show the demand as a percentage. i.e. C 5 0.

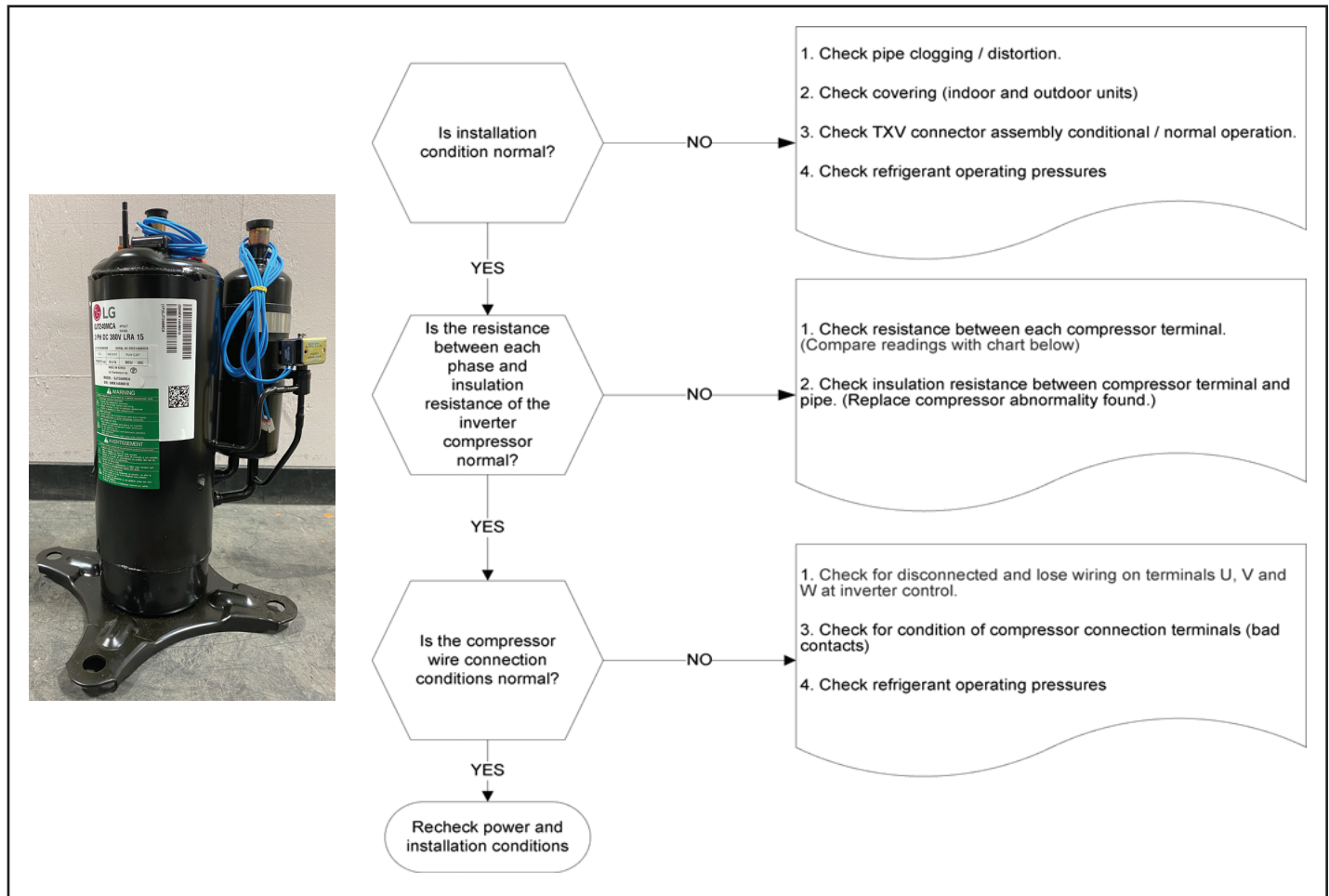


FIGURE 34. Compressor Operation, Checkout and Status/Error Codes

## ERROR CODES:

TABLE 13. Outdoor Control 7-Segment Display Alert Codes - Compressor

System fault and lockout codes take precedence over system status codes (cooling, heating operating percentages or defrost/dehumidification). Only the latest active fault or lockout codes are displayed (if present). If no fault or lockout codes are active, then system status codes are displayed. Alert codes are also displayed on the S40 thermostat on systems installed with the S40 thermostat.

Alert Codes	Inverter Code	Inverter LED Flash Code (number of flashes)		Priority	Alarm Description	Possible Causes and Clearing Alarm
		Red LED	Green LED			
E 430	26	2 flashes	6 flashes	Service Soon / Service Urgent	Compressor start failure	If condition is detected, outdoor unit compressor and fan stop. Antishort cycle is initiated. If condition occurs 10 times within an hour, system is locked out. Indicates poor connection at compressor harness, improper winding resistance, locked compressor rotor, or flooded compressor. To clear, disconnect power to the indoor unit (24VAC power source to the outdoor control) which will power off the outdoor control and will open the outdoor unit contactor, which interrupts power to the inverter and then re-apply power.

**TABLE 13. Outdoor Control 7-Segment Display Alert Codes - Compressor**

System fault and lockout codes take precedence over system status codes (cooling, heating operating percentages or defrost/dehumidification). Only the latest active fault or lockout codes are displayed (if present). If no fault or lockout codes are active, then system status codes are displayed. Alert codes are also displayed on the S40 thermostat on systems installed with the S40 thermostat.

Alert Codes	Inverter Code	Inverter LED Flash Code (number of flashes)		Priority	Alarm Description	Possible Causes and Clearing Alarm
		Red LED	Green LED			
E 433	29	2 flashes	9 flashes	Service Soon / Service Urgent	The inverter has detected a compressor over-current condition.	Error occurs when compressor peak phase current is greater than 28A. Inverter issues code 14 first and slows down to try to reduce the current. If the current remains high, outdoor unit compressor and fan stop. Antishort cycle is initiated. If condition occurs 5 times within an hour, the unitary control will cycle the contactor to prevent the unit from locking out.  To clear, disconnect power to the indoor unit (24VAC power source to the outdoor control) which will power off the outdoor control and will open the outdoor unit contactor, which interrupts power to the inverter and then re-apply power.
E 439	12	1 flash	2 flashes	Service Soon	Compressor slowdown due to high input current.	Input current is approaching a high limit. Compressor speed automatically slows. The control continues sending the inverter speed demanded by the thermostat. The control sets indoor CFM and outdoor RPM to values according to demand percentage rather than the actual Hz. Alarm is automatically clear.
E 440	13	1 flash	3 flashes	Information Only - Dealer	Heat sink temperature is approaching limit. The compressor speed automatically slows to reduce heat sink temperature. The control sets indoor CFM and outdoor RPM to values according to demand percentage rather than the actual Hz. Alarm is automatically cleared.	This error code is primarily for informational purposes as the inverter controls the compressor speed to operate within design parameters. Typically the inverter will make a minor speed reduction of 4 Hz (approximately a 5-6% speed reduction) for a brief period of time and to reduce the heat sink temperature and will then resume normal operation. This may occur at high outdoor temperatures (above 110°F) for brief periods of time (3 – 4 minutes) and is normal and expected operation of the inverter controlling the compressor safely within design parameters.  The inverter finned aluminum heat sink is located on the back side of the inverter in the condenser air stream. If the alert code 440 occur frequently, especially at lower outdoor temperatures, check the heat sink for debris that may reduce heat transfer or possible obstructions that may impact air flow across the heat sink.  The inverter will begin to briefly reduce the compressor speed when the heat sink temperature rises above 167°F and will allow the inverter to resume the requested compressor demand speed once the inverter heat sink reaches 150°F. The heat sink temperature, compressor speed in Hertz the Inverter Compressor Speed Reduction status (“On” or “Off”) notification can be viewed under the outdoor unit Diagnostics section of the thermostat dealer control center on units installed with an S40 thermostat.
E 441	14	1 flash	4 flashes	Information Only - Dealer	Compressor slowdown due to high compressor current. Compressor current is approaching limit. The compressor speed automatically slows. The control sets indoor CFM and outdoor RPM to values according to demand percentage rather than the actual Hz. Alarm is automatically cleared	This error code is primarily for informational purposes as the inverter controls the compressor to operate within design parameters. Alert code 441 typically occurs at startup as the compressor as the currently increases rapidly during startup.  The inverter will reduce the compressor speed by 4 hz and slow the compressor ramp up speed to the requested compressor demand (capacity). This is normal and expected operation of the inverter to control the compressor within design parameters. In most cases the alert code 441 does not require any additional service or diagnostic procedures.  E441 may also occur if the system is operating at high pressures.
E 600	N/A	N/A	N/A	Service Urgent	Compressor has been cycled OFF by utility load-shedding function.	Load-shedding function: Provides a method for a local utility company to limit the maximum power level usage of the outdoor unit. The feature is activated by applying 24 volts AC power to the L and C terminals on the outdoor control.

## Crankcase Heater, Checkout and Status / Error Codes

### OPERATION:

#### CRANKCASE HEATER (HR1)

Compressors in all units are equipped with a 40 watt belly-band type crankcase heater. The heater prevents liquid from accumulating in the compressor. The heater is controlled by the crankcase heater thermostat.

#### CRANKCASE HEATER THERMOSTAT (S40)

Crankcase heater thermostat S40 controls the crankcase heater in all units and is integrated onto the heater.

1. When compressor temperature drops below 50°F the thermostat closes which results in the heater being energized.
2. When compressor temperature rises above 70°F the thermostat opens which results in the heater being de-energized.

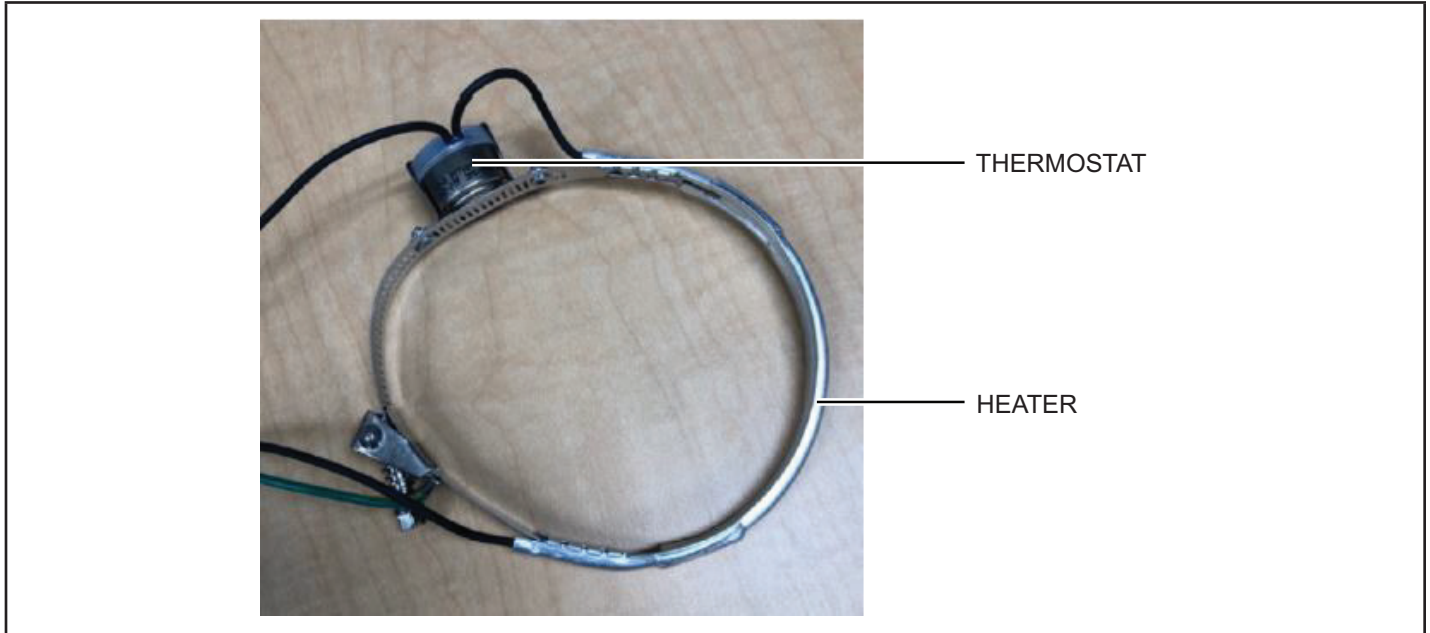


FIGURE 35. Belly-Band Crankcase Heater and Thermostat

### CHECKOUT:

**Belly-Band Crankcase Heater:** Using meter set on ohms, check crankcase heater resistance. If resistance is 0 ohms or infinite, replace the crankcase heater.

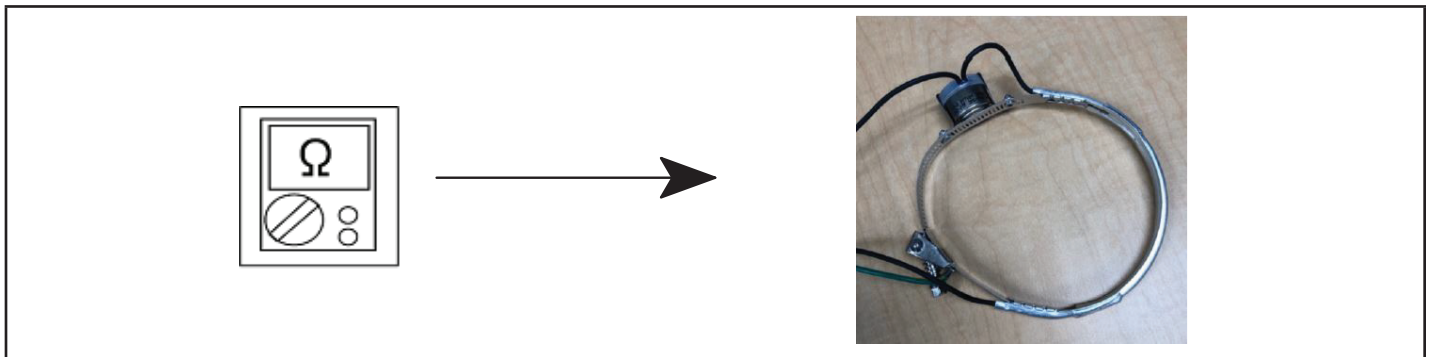
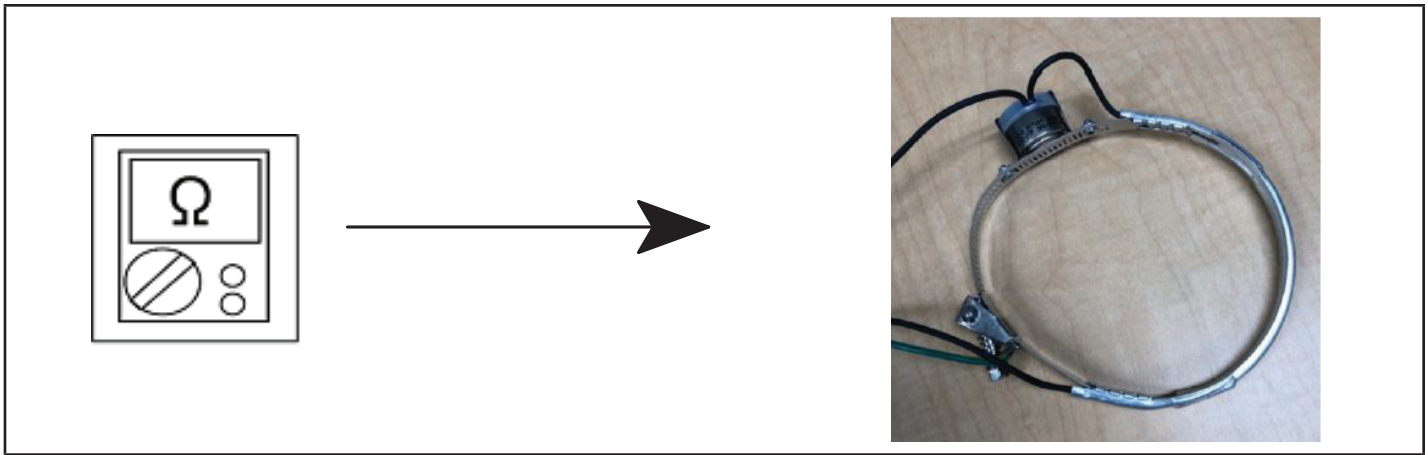


FIGURE 36. Checking Belly-Band Crankcase Heater

**Crankcase Heater Thermostat:** As the detected temperature changes, the resistance across the sensor changes. Table 17 on page 79 shows how the resistance varies as the temperature changes for this sensor.

**NOTE** – When checking the ohms across a sensor, be aware that a sensor showing a resistance value that is not within the expected range may be performing as designed. However, if a shorted or open circuit is detected, the sensor is faulty; the sensor needs to be replaced.



**FIGURE 37. Checking Crankcase Heater Thermostat**

**STATUS CODE:**

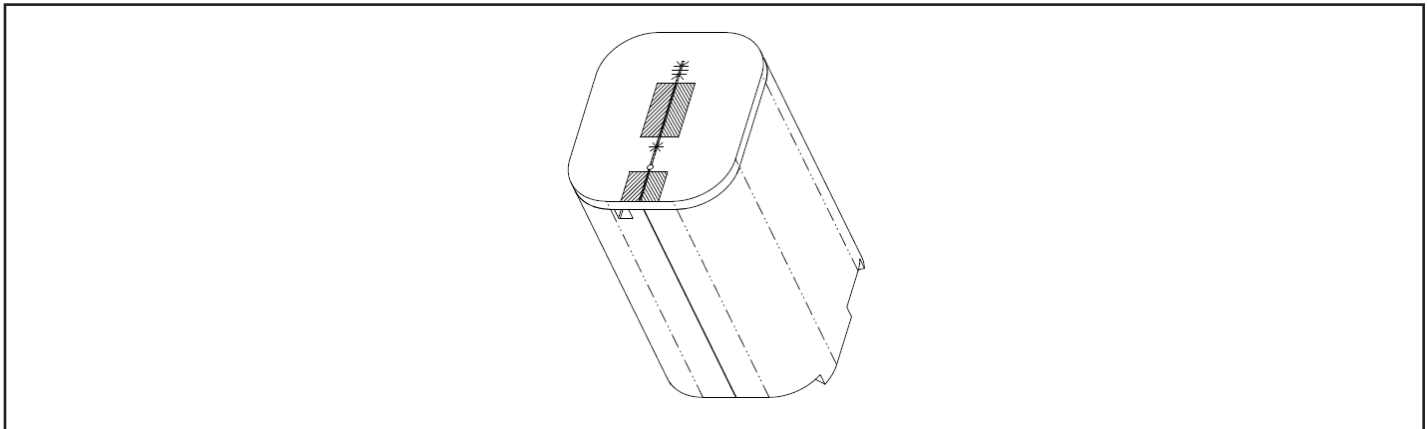
None

**ERROR CODES:**

None

**Compressor Sound Cover**

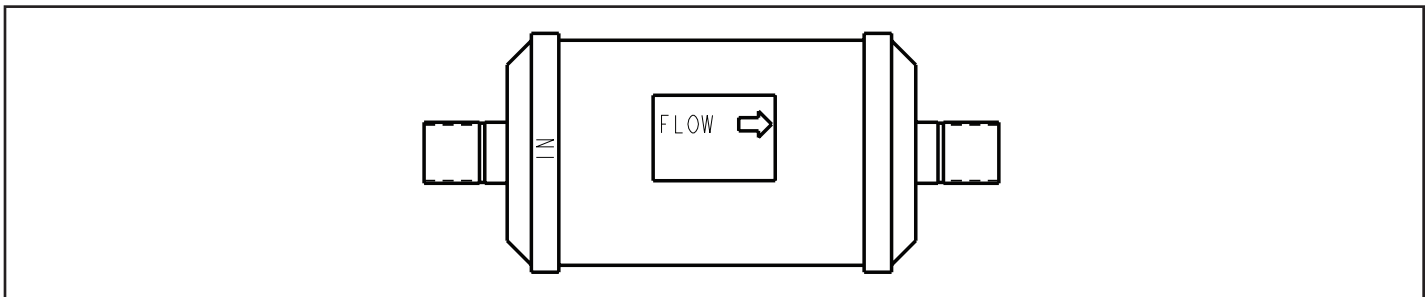
All units come with a soft-sided polyethylene molded outer shell compressor sound cover. The cover helps reduce any unwanted operating sounds from the compressor. The cover features a hook/loop closure system for ease of installation on the compressor.



**FIGURE 38. Compressor Sound Cover**

**Suction Line Filter Drier**

The EL19KPV units have a rotary compressor and have a factory installed suction line filter drier installed in the suction line. Liquid drier is not required, but may be field installed. The filter drier is designed to remove moisture and foreign matter, which can lead to compressor failure.



**FIGURE 39. Suction Line Filter Drier**

## Top Cap Switch Operation, Checkout and Status / Error Codes

### OPERATION:

#### Top Cap Thermal Sensor Switch (S173)

Some units are equipped with a compressor-mounted normally closed temperature switch that prevents compressor damage due to overheating caused by internal friction. The switch is located on top of the compressor casing. This switch senses the compressor casing temperature and opens at 221-239°F to shut off compressor operation. The auto-reset switch closes when the compressor casing temperature falls to 140-176°F, and the compressor is re-energized. This is a single-pole, single-throw (SPST) bi-metallic switch.

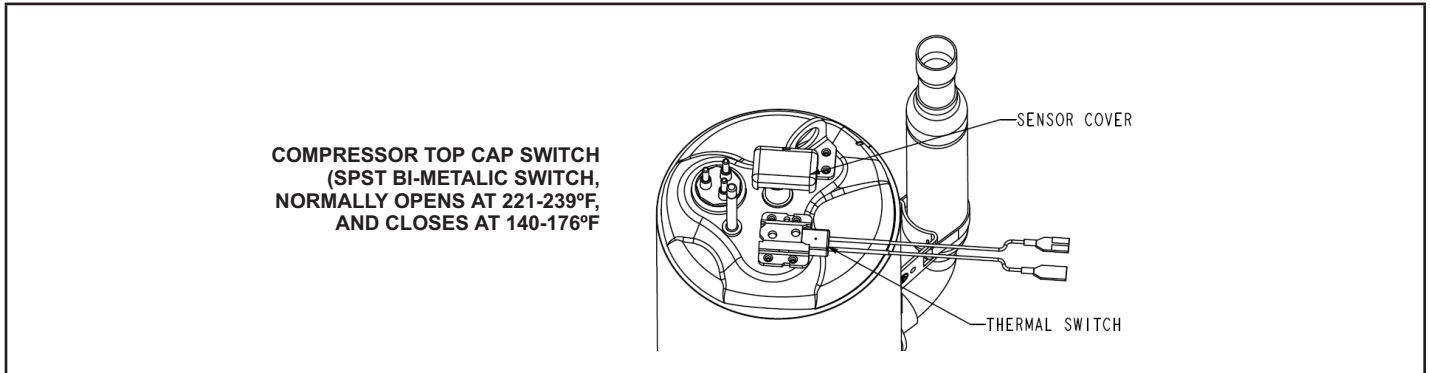


FIGURE 40. Top Cap Thermal Sensor Switch

### CHECKOUT:

Using a multimeter set to ohms, with the terminals disconnected from the system, check the resistance between the two terminals of the top cap switch. If the meter display does not change, the switch is open. If the meter display goes to infinite, the switch is closed.

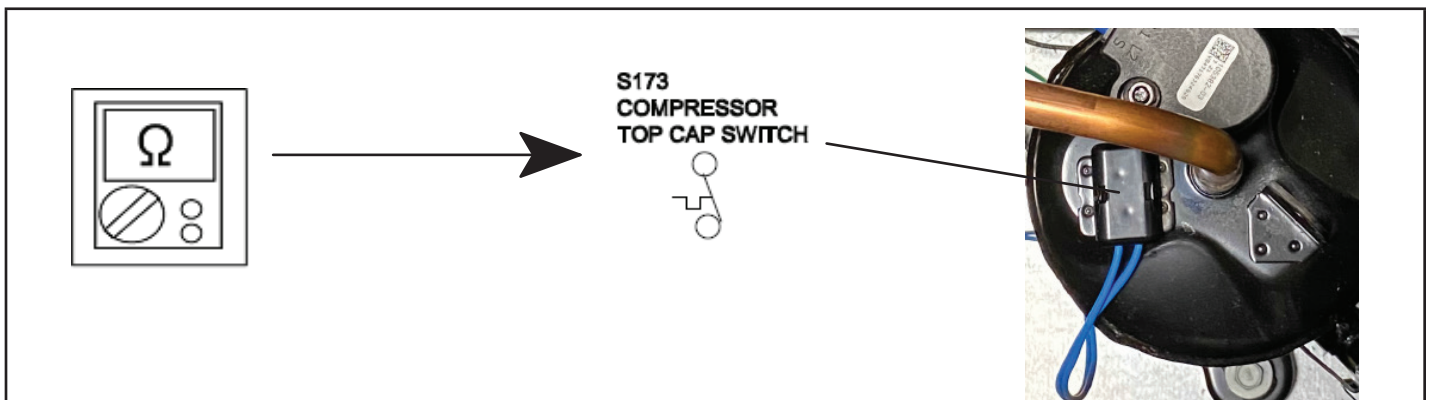


FIGURE 41. Verifying Top Cap Thermal Sensor Switch

### STATUS:

None

**ERROR:**

<b>TABLE 14. Outdoor Control 7-Segment Display Alert Codes - Top Cap Switch</b>			
<i>NOTE - System fault and lockout codes take precedence over system status codes (cooling, heating operating percentages or de-frost/dehumidification). Only the latest active fault or lockout codes are displayed (if present). If no fault or lockout codes are active, then system status codes are displayed. Alert codes are also displayed on the communicating thermostat.</i>			
<b>Alert Codes</b>	<b>Priority</b>	<b>Alarm Description</b>	<b>Possible Causes and Clearing Alarm</b>
E 422	Service Soon	Compressor top cap switch exceeding thermal limit.	The top of the compressor is hot. Refrigerant charge may be low, or low mass flow of refrigerant. Check TXV, clogged filter drier, condenser fan motor, indoor blower motor, confirm indoor coil is clean. Check to make sure the blue wires from the top thermostat did not get pulled off one of the TP terminal on the outdoor control board.
E 442	Service Urgent	The top cap switch has opened 5 times within one hour. As a result, the outdoor unit is locked out.	When compressor thermal protection sensor opens 5 times within 1 hour, outdoor stops working. To clear, disconnect power to the indoor unit (24VAC power source to the outdoor control) which will power off the outdoor control and will open the outdoor unit contactor, which interrupts power to the inverter and then re-apply power.

**Reactor Operations, Checkout and Status / Error Codes**

**OPERATION:**

Reactor (Inductor or choke) is a passive two-terminal electrical component that stores energy in its magnetic field. Reactors are one of the basic components used in electronics where current and voltage change with time, due to the ability of inductors to delay and reshape alternating currents.

**CHECKOUT:**

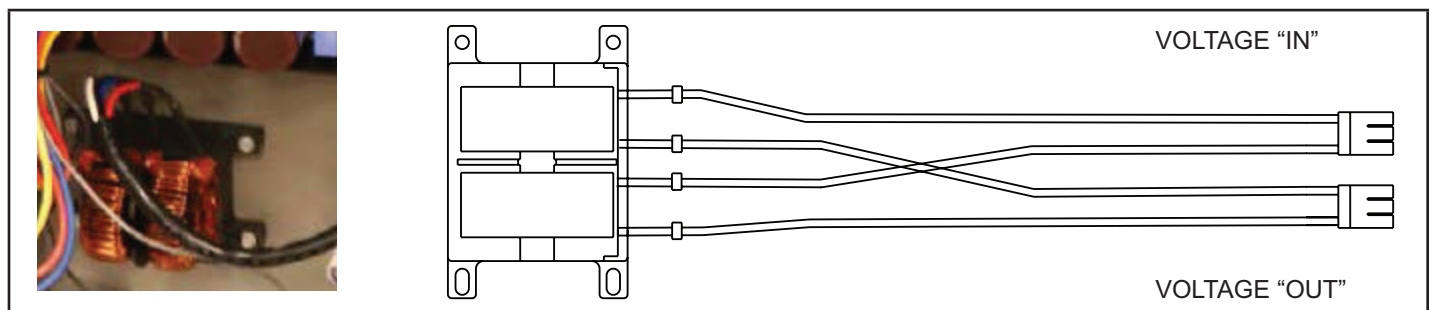
Main Power ON – Voltage IN reactor should be the same as the voltage OUT. With main power OFF and reactor disconnected from system; resistance between leads should be the same

**STATUS CODES:**

None

**ERROR CODES:**

None



**FIGURE 42. EL19KPV Reactor**

**Outdoor Fan Operation and Checkout**

**OPERATION:**

The EL19KPV units have a variable speed ECM fan motor. The variable speed ECM fan motor is controlled by PWM fan output when the compressor is running and will vary the fan speed to match the compressor capacity.

**LOW AMBIENT OPERATION:**

The EL19KPV units have factory installed low ambient cooling mode operation that will control the condenser fan motor based upon liquid line temperature.

The EL19KPV units have a variable speed ECM fan motor. The outdoor control will begin to modulate the outdoor fan motor speed is below 65°F to maintain a liquid line sensor temperature between 58°F and 70°F. If the liquid line sensor drops below 55°F the control will cycle the fan off until liquid temperature rises above 58°F.



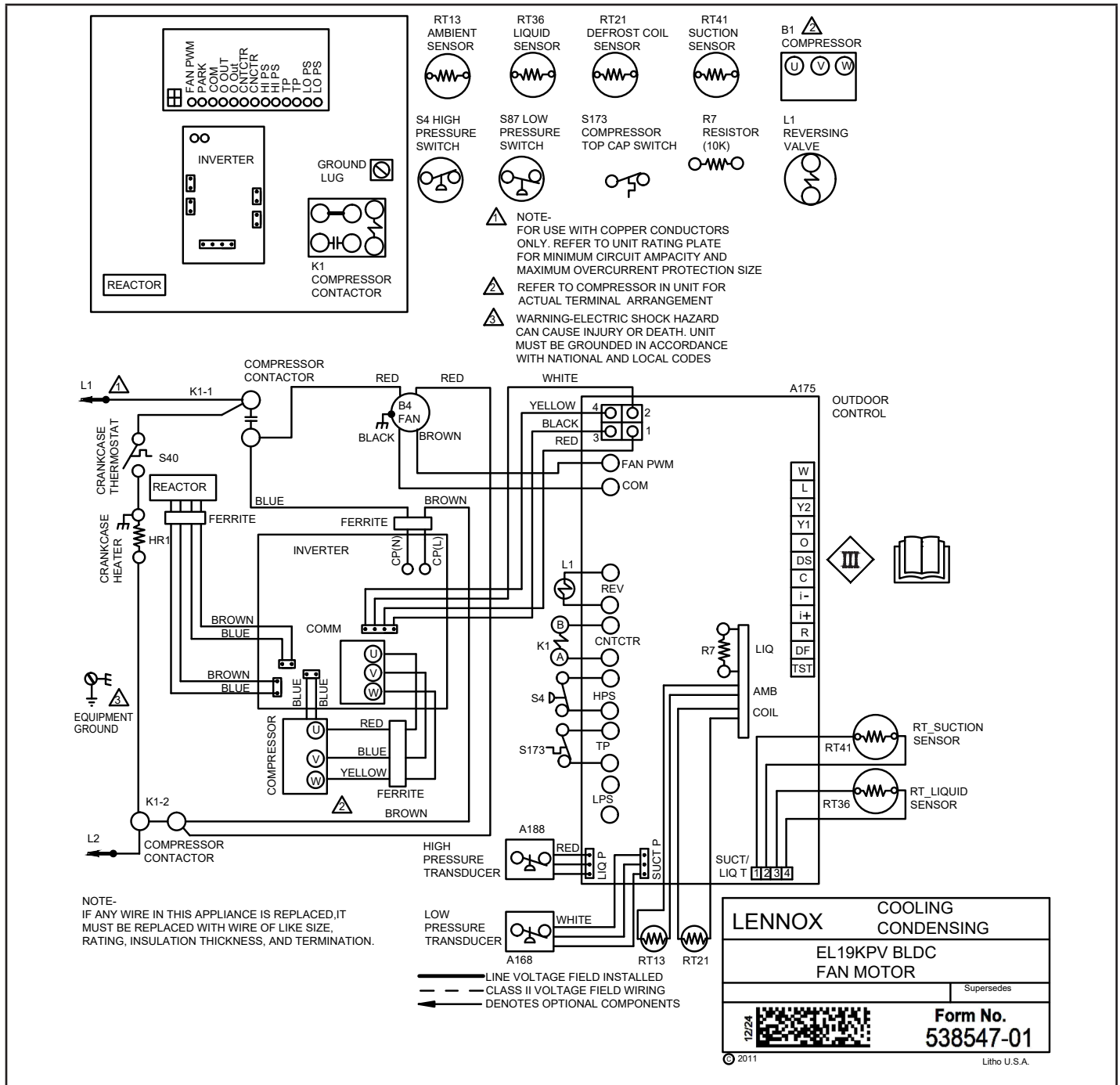
**CHECKOUT:**

**VAC Voltage Check**

Check for 208/240 VAC power at inverter contactor (red wires) (see figure 42).

Units with ECM Motor

1. With the unit running, check for 230VAC at the red outdoor fan motor wires at the contactor. If no voltage is present check main power at the contactor.
2. Perform a DC voltage check between the FPWM and Fan C terminal.
3. Using the push button on the control, enter the "fan test mode" in the "field test mode" by pushing and holding the button until solid "-" appears, release the button. Display will start flashing, within 10 seconds, push and hold the button until the "F" symbol displays then release the button. Display will begin to flash "F", within 10 seconds, push and hold the button until it stops flashing, release the button. Outdoor fan motor will cycle on for 10 minutes. To exit, push and hold the button until three horizontal bars display. Release the button and the outdoor fan will cycle off.



**FIGURE 43. VAC Voltage Check**

## Outdoor Control Operation, Checkout and Status / Error Codes

### OPERATION:

The outdoor control is a microprocessor-based device for use with variable-capacity compressors up to 5-tons in capacity operating on 24VAC residential power. The outdoor control integrates the functionality of maintaining compressor speed, and outdoor fan control of ECM motors. The outdoor control is self-configuring. During start-up the outdoor control selects one of two configurations variable-capacity air conditioner or variable-capacity heat pump.

The EL19KPV outdoor control provides application flexibility. The EL19KPV may be installed with an S40 communicating thermostat in a fully communicating system or with a conventional 24VAC non-communicating single or two stage heat pump thermostat.

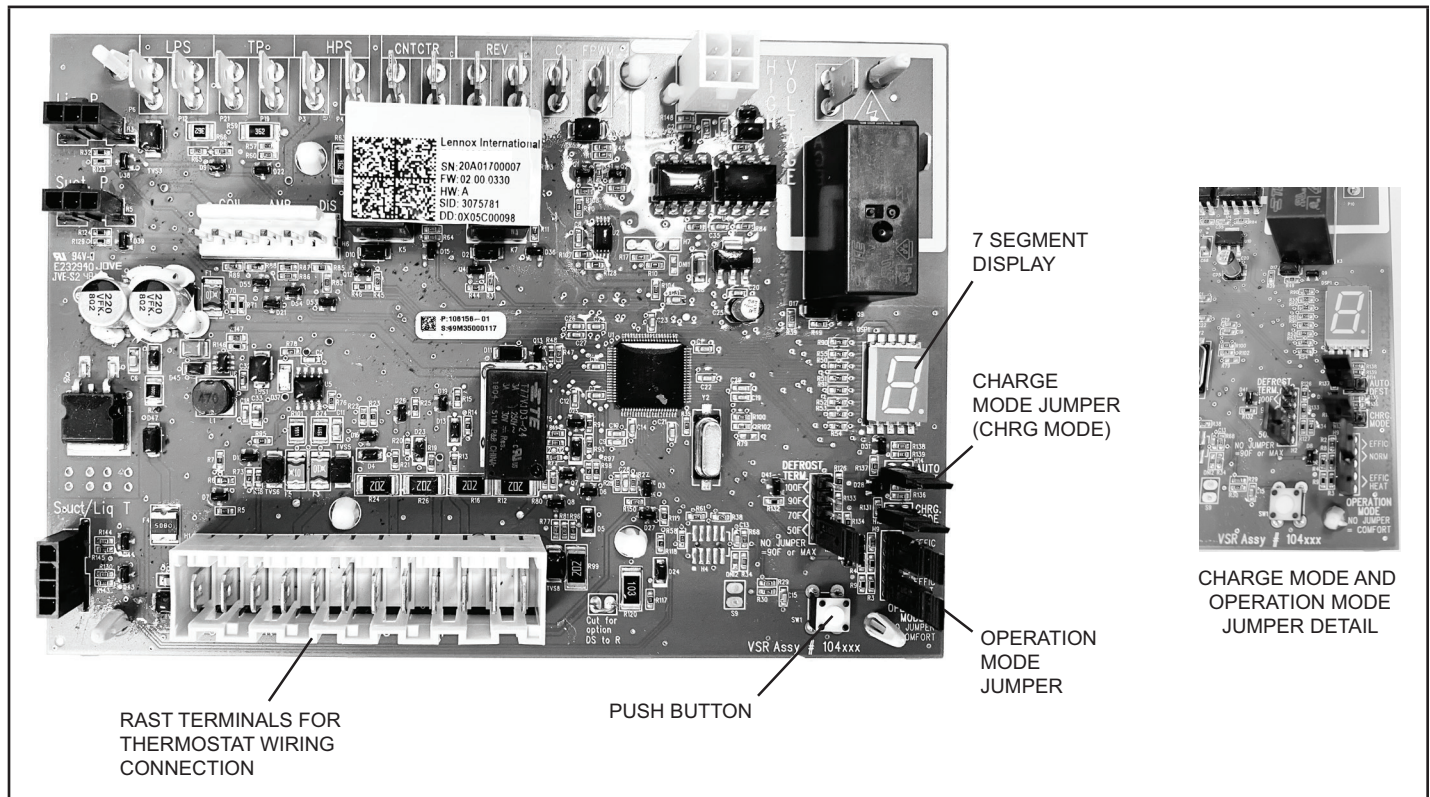


FIGURE 44. Outdoor Control Unit

### STATUS CODES:

**TABLE 15. Outdoor Control 7-Segment Display Alert Codes - Outdoor Control Status**

*NOTE - System fault and lockout codes take precedence over system status codes (cooling, heating operating percentages or defrost/dehumidification). Only the latest active fault or lockout codes are displayed (if present). If no fault or lockout codes are active, then system status codes are displayed. Alert codes are also displayed on the S40 thermostat.*

Alert Codes	Priority	Alarm Description	Possible Causes and Clearing Alarm
E 600	Service Urgent	Compressor has been cycled OFF on utility load shedding	Load shedding function: Provides a method for a local utility company to limit the maximum power level usage of the outdoor unit. The feature is activated by applying 24 volts AC power to the L and C terminals on the outdoor control.
E 601	Service Urgent	Outdoor unit has been cycled OFF on low temperature protection.	Low temperature Protection: Outdoor unit will not operate when the outdoor temperature is at or below -4° F (-20°C). If the unit is operating and the outdoor temperature drops below -4°F (-20°C), the unit will continue to operate until the room thermostat is satisfied or the outdoor temperature drops to -15°F (-26°C). (Outdoor unit ambient sensor provides temperature readings.)

## System Configuration

### EL19KPV Thermostat Control Options

The EL19KPV variable capacity units provide two thermostat control options to provide application and installation flexibility.

#### S40 Communicating Thermostat Control

The EL19KPV variable capacity unit may be installed as a fully communicating system consisting of S40 Communicating Thermostat, an indoor unit and the EL19KPV variable capacity outdoor unit wired with (4) communication wires (R, I+, I- and C) connected to the EL19KPV Outdoor Unitary Control.

The EL19KPV variable capacity unit when wired as a fully communicating system will take full advantage of the advanced diagnostics and control, Wi-Fi accessibility and system operation parameters. Refer to the EL19KPV field wiring diagram for an S40 communicating thermostat.

### Conventional 24VAC Non-Communicating Heat Pump Thermostat Control

The EL19KPV variable capacity unit may be installed using a conventional 24VAC non-communicating two-stage cooling or single-stage heat pump thermostat.

**NOTE** – The conventional 24VAC non-communicating thermostat must have a compressor minimum on time of three minutes to prevent compressor short cycling. The Lennox M30, ComfortSense 7500, ComfortSense 3000 and many other commercially available electronic thermostats provide this feature.

The EL19KPV unit will provide full variable capacity operation when installed with a conventional 24VAC non-communicating two stage or single-stage heat pump thermostat. The EL19KPV outdoor control has advanced control algorithms using the EL19KPV suction pressure sensor in the cooling mode and liquid pressure sensor in the heating mode to provide true variable capacity compressor operation.

When utilizing a two-stage conventional 24VAC non-communicating heat pump thermostat, six wires are required to control the outdoor unit (R, C, Y1, Y2, O and W). Refer to the EL19KPV field wiring diagram for a conventional 24VAC non-communicating 2-stage heat pump thermostat.

EL19KPV Thermostat Control Options

Thermostat Type	Indoor Unit Type	Qty. of Wires to EL19KPV	EL19KPV Terminal Strip Connections	Unit Operation	Field Wiring Diagram
S40 Communicating Thermostat	Communicating Gas Furnace or Air Handler	4	R, I+, I-, C	Fully Communicating Variable Capacity Operation Based Upon Thermostat Demand	Figure 15
Conventional 24VAC 2-Stage Heat Pump Thermostat (non-communicating)	Any Furnace or Air Handler (non-communicating or communicating)	6	R, C, Y1, Y2, O, W	Full Variable Capacity Operation Controlled by EL19KPV Unitary Control Using Suction Pressure in Cooling Mode and Liquid Pressure in Heating Mode	Figure 16

## Cooling Operation Mode Jumper

The Cooling Operation Mode Jumper is only used on applications installed with a conventional 24VAC non-communicating heat pump thermostat. In applications with a conventional 24VAC non-communicating heat pump thermostat, the compressor capacity is controlled to maintain the target suction pressure setpoint. The Cooling Operation Mode Jumper has three selectable cooling modes. The three modes are Efficiency (Jumper installed on Pins 1 and 2), Normal Mode (Jumper installed on Pins 2 and 3) and Comfort Mode (Jumper Removed). The factory default position is the Efficiency Mode. The Efficiency mode has a variable suction pressure setpoint that will vary with the outdoor temperature; as the outdoor temperature increases the suction pressure setpoint will decrease. When the Cooling Operation Mode jumper is installed in the “Normal Mode” the suction pressure setpoint is 135 psig.

When the Cooling Operation Mode jumper is installed in the “Comfort Mode” the suction pressure setpoint is 125 psig.

## Cooling Operation Mode Jumper (Conventional 24VAV Thermostats Only)

Operation Mode Jumper	Jumper Position	Target Suction Pressure Setting
Efficiency (default)	Pin 1 to Pin 2	Variable based on OAT
Normal	Pin 2 to Pin 3	135 PSIG
Comfort	Jumper Off	125 PSIG

## Heating Operation Mode Jumper

The Heating Operation Mode Jumper is only used on applications installed with a conventional 24VAC non-communicating heat pump thermostat. In applications with a conventional 24VAC non-communicating heat pump thermostat, the compressor capacity is controlled to maintain the target liquid pressure setpoint. The Heating Operation Mode Jumper has two selectable heating modes. The two modes are Efficiency (Jumper installed on Pins 1 and 2) and Comfort Mode (Jumper Removed). The factory default position is the Efficiency Mode. The Efficiency mode has a variable liquid pressure setpoint that will vary with the outdoor temperature; as the outdoor temperature decreases, the liquid pressure setpoint will increase. When the Operation Mode jumper is installed in the “Comfort Mode” the liquid pressure setpoint is 425 psig.

### Heating Operation Mode Jumper (Conventional 24VAV Thermostats Only)

Operation Mode Jumper	Jumper Position	Target Liquid Pressure Setting
Efficiency (default)	Pin 4 to Pin 5	Variable based on OAT
Comfort	Jumper Off	425 PSIG

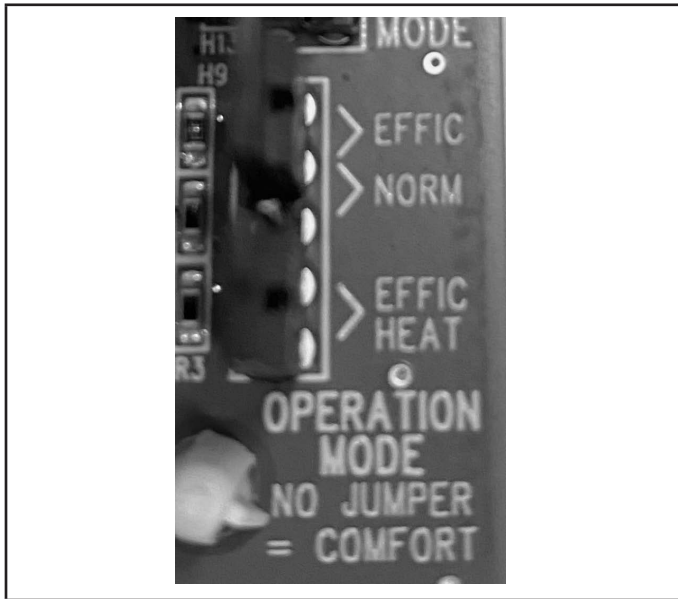


FIGURE 45. Operation Mode Jumper

### Unit Operation

#### EL19KPV Unit Operation with a S40 Communicating Thermostat

When the EL19KPV unit is installed with a S40 Communicating Thermostat and indoor unit, the unit capacity will be controlled in the variable capacity mode throughout the range of capacity from minimum capacity to maximum capacity based upon thermostat demand in both the cooling and heat pump heating mode. The indoor air volume will be controlled to match compressor capacity throughout the capacity range.

#### EL19KPV Unit Operation with a Conventional 24VAC Non-Communicating 2-Stage Heat Pump Thermostat – Cooling Mode

When the EL19KPV unit is installed with a conventional 24VAC non-communicating 2-stage heat pump thermostat, the O terminal on the thermostat will energize the unit reversing valve to place the unit in the cooling mode. A Y1 first stage cooling demand will initiate cooling operation and first stage indoor blower operation. The compressor will be controlled in the variable capacity mode by varying the compressor capacity to obtain the target suction pressure set point. The Y2 second stage cooling demand will initiate second stage blower operation. Increased air volume will increase the load on the indoor coil and increase the

suction pressure. The EL19KPV compressor capacity will continue to be controlled based upon the suction pressure. The unit capacity will be controlled in the variable capacity mode throughout the range of capacity from minimum capacity to maximum capacity. If the Y2 demand remains after 20 minutes, the EL19KPV control will begin to ramp up the compressor capacity until maximum capacity is achieved. The EL19KPV unit will cycle off once the thermostat demand is satisfied.

#### EL19KPV Unit Operation with a Conventional 24VAC Non-Communicating 2-Stage Heat Pump Thermostat - Heating Mode

When the EL19KPV unit is installed with a conventional 24VAC non-communicating 2-stage heat pump thermostat, O terminal is not powered during the heating mode and the reversing valve is de-energized placing the unit in the heating mode. A Y1 first stage compressor demand will initiate compressor operation and first stage indoor blower operation. The compressor will be controlled in the variable capacity mode by varying the compressor capacity to obtain the target liquid pressure set point. The Y2 second stage compressor demand will initiate second stage blower operation. Increased air volume will increase heat transfer on the indoor coil and decrease the liquid pressure. If the liquid pressure drops below the target setpoint, the compressor capacity will be increased. The EL19KPV compressor capacity will continue to be controlled based upon the liquid pressure. The unit capacity will be controlled in the variable capacity mode throughout the range of capacity from minimum capacity to maximum capacity. If the Y2 demand remains after 20 minutes, the EL19KPV control will begin to ramp up the compressor capacity until maximum capacity is achieved. The EL19KPV unit will cycle off once the thermostat demand is satisfied.

#### EL19KPV Unit Operation with a Conventional 24VAC Non-Communicating Single-Stage Heat Pump Thermostat – Cooling Mode

When the EL19KPV unit is installed with a conventional 24VAC non-communicating single-stage heat pump thermostat, the O terminal on the thermostat will energize the unit reversing valve to place the unit in the cooling mode. A Y1 first stage cooling demand will initiate cooling operation and cooling indoor blower operation. In single stage thermostat applications, a jumper must be installed between Y1 and Y2 on the EL19KPV outdoor control. The compressor will be controlled in the variable capacity mode by varying the compressor capacity to obtain the target suction pressure set point. If the cooling demand remains after 20 minutes, the EL19KPV control will begin to ramp up the compressor capacity until maximum capacity is achieved. The EL19KPV unit will cycle off once the thermostat demand is satisfied.

## ERROR CODES:

**TABLE 16. Outdoor Control 7-Segment Display Alert Codes - Outdoor Control Errors**

*NOTE - System fault and lockout codes take precedence over system status codes (cooling, heating operating percentages or defrost/dehumidification). Only the latest active fault or lockout codes are displayed (if present). If no fault or lockout codes are active, then system status codes are displayed. Alert codes are also displayed on the S40 thermostat.*

Alert Codes	Priority	Alarm Description	Possible Causes and Clearing Alarm
E 105	Service Soon	The outdoor control has lost communication with either the thermostat or indoor unit.	Equipment is unable to communicate. Indicates numerous message errors. In most cases errors are related to electrical noise. Make sure high voltage power is separated from RSBus. Check for miswired and/or loose connections between the stat, indoor unit and outdoor unit. Check for a high voltage source of noise close to the system. Fault clears after communication is restored.
E 120	Service Soon	There is a delay in the outdoor unit responding to the system.	Typically, this alarm/code does not cause any issues and will clear on its own. The alarm / code is usually caused by a delay in the outdoor unit responding to the thermostat. Check all wiring connections. Cleared after unresponsive device responds to any inquiry.
E 124	Service Urgent	The S40 thermostat has lost communication with the outdoor unit for more than 3 minutes.	Equipment lost communication with the thermostat. Check the wiring connections, ohm wires and cycle power. The alarm stops all associated HVAC operations and waits for a heartbeat message from the unit that's not communicating. The alarm / fault clears after communication is re-established.
E 125	Service Urgent	There is a hardware problem with the outdoor control.	There is a control hardware problem. Replace the outdoor control if the problem prevents operation and is persistent. The alarm / fault is cleared 300 seconds after the fault recovers
E 131	Service Urgent	The outdoor unit control parameters are corrupted	Reconfigure the system. Replace the control if heating or cooling is not available.
E 132	Service Urgent	Internal software error	Replace outdoor control.

## Unit Sensor Operation, Checkout and Status /Error Codes

### OPERATION:

#### 6-Pin Sensor Harness (LIQ, AMB, COIL)

##### Discharge Sensor (R7 - No Sensor)

There is no sensor located on positions 5 and 6 of the connector. A 10K Ohm resistor installed between pins 5 and 6 on the cable harness provides continuity for this circuit.

##### Ambient Temperature Sensor (RT13)

Ambient temperatures, as read by the ambient temperature sensor connected to pin 3 and pin 4, which are below -35°F (-37°C) or above 120°F (48°C) trigger a fault condition. If the ambient sensor is open, shorted, or out of the temperature range of the sensor, the control displays the appropriate alert code. Heating and cooling operation is allowed in this fault condition

##### Coil Temperature Sensor (RT21)

The liquid temperature sensor located on the outlet of the outdoor TXV is connected to pins 5 and 6.

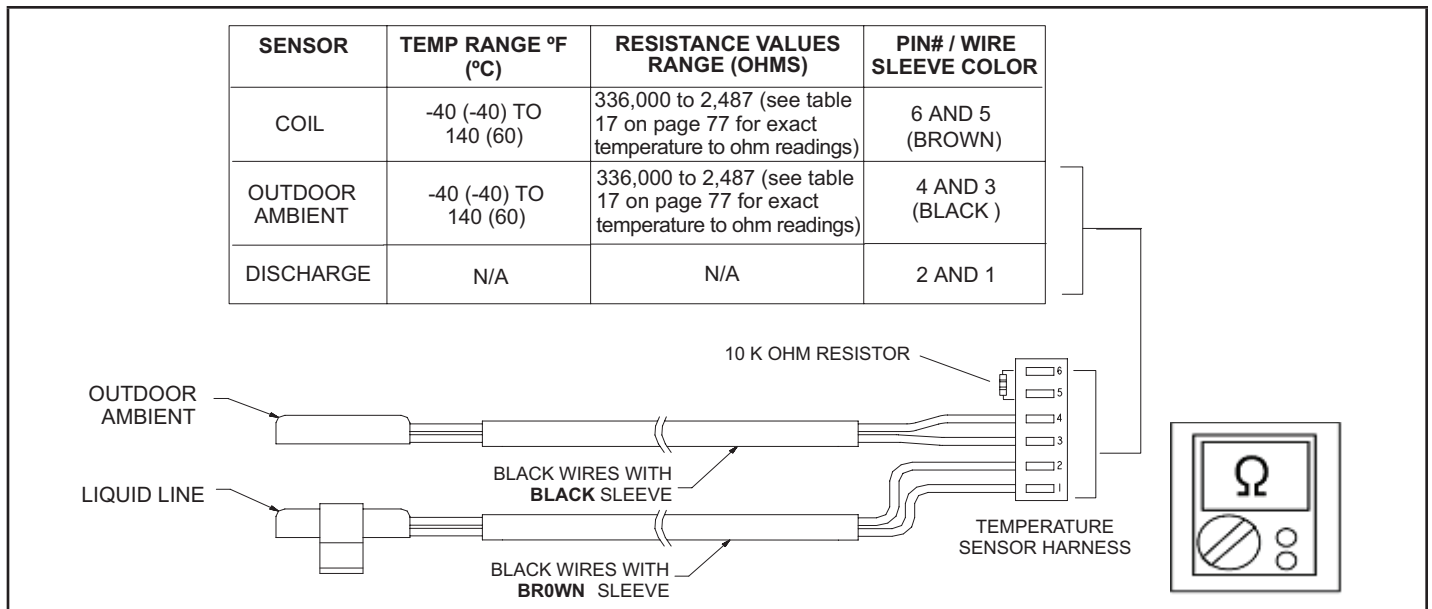
#### 4-Pin Suction Temperature Sensor / Liquid Temperature Sensor Harness

##### Suction Line Sensor (RT41)

Suction line temperature is read by the suction line temperature sensor between Pins 1 and Pin 2 of the 4-pin sensor harness. Nominal Resistance of the sensor is 10K ohms at 77F. The control will display are E182 error code if the sensor reads open or shorted for 24 hours. Cooling operation is allowed with this fault.

##### Liquid Line Temperature Sensor (RT36)

Liquid line temperature is read by the liquid line temperature sensor between Pins 3 and Pin 4 of the 4-pin sensor harness. Nominal Resistance of the sensor is 10K ohms at 77F. The control will display are E184 error code if the sensor reads open or shorted for 24 hours. Cooling operation is allowed with this fault.

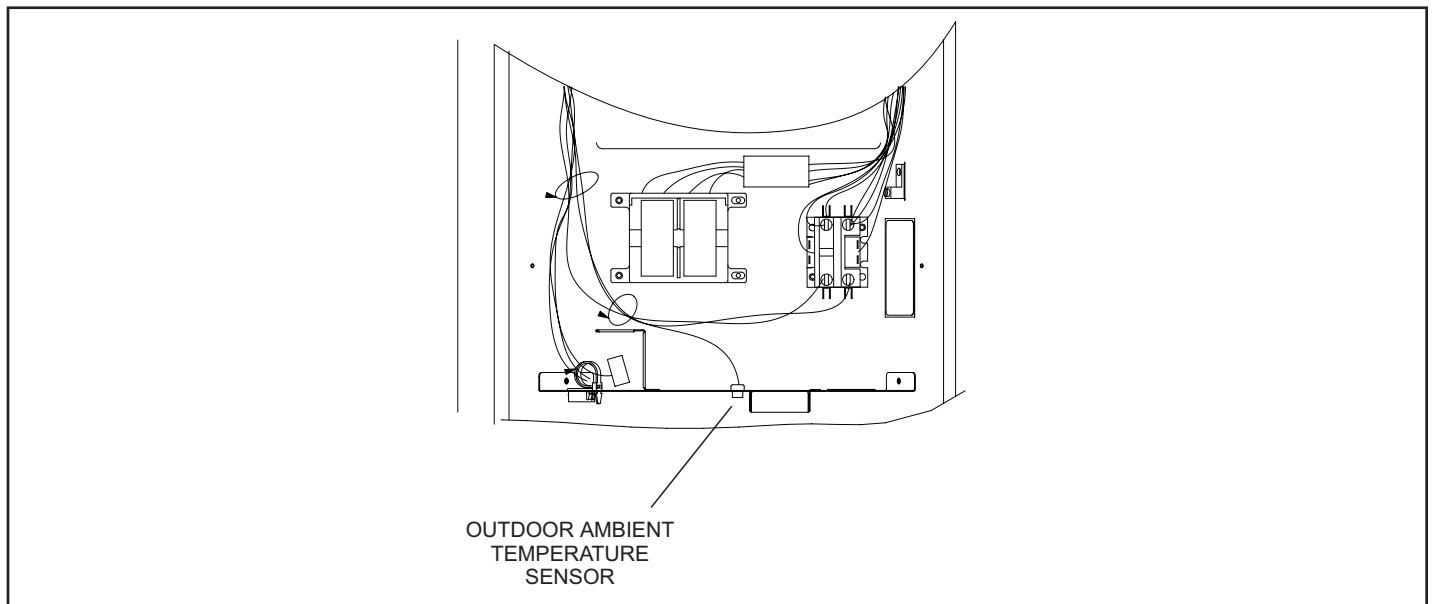


**FIGURE 46. Temperature Sensor Specification**

**CHECKOUT:**

Sensors connect to the outdoor control through a field-replaceable harness assembly that plugs into the outdoor control. Through the sensors, the control detects outdoor ambient, coil and liquid temperature fault conditions. As the detected temperature changes, the resistance across the sensor changes. Check sensor operation by reading ohms across pins shown in figure 46.

**NOTE** – When checking the ohms across a sensor, be aware that a sensor showing a resistance value that is not within the expected range may be performing as designed. However, if a shorted or open circuit is detected, then the sensor may be faulty and the sensor harness will need to be replaced.



**FIGURE 47. Temperature Sensor Location**

**TABLE 17. Ambient and Coil Sensors Temperature / Resistance Range**

Degrees Fahr- enheit	Resistance	Degrees Fahr- enheit	Resistance	Degrees Fahr- enheit	Resistance	Degrees Fahr- enheit	Resistance
136.3	2680	56.8	16657	21.6	44154	-11.3	123152
133.1	2859	56.0	16973	21.0	44851	-11.9	125787
130.1	3040	55.3	17293	20.5	45560	-12.6	128508
127.3	3223	54.6	17616	20.0	46281	-13.2	131320
124.7	3407	53.9	17942	19.4	47014	-13.9	134227
122.1	3592	53.2	18273	18.9	47759	-14.5	137234
119.7	3779	52.5	18607	18.4	48517	-15.2	140347
117.5	3968	51.9	18945	17.8	49289	-15.9	143571
115.3	4159	51.2	19287	17.3	50074	-16.5	146913
113.2	4351	50.5	19633	16.8	50873	-17.2	150378
111.2	4544	49.9	19982	16.3	51686	-17.9	153974
109.3	4740	49.2	20336	15.7	52514	-18.6	157708
107.4	4937	48.5	20695	15.2	53356	-19.3	161588
105.6	5136	47.9	21057	14.7	54215	-20.1	165624
103.9	5336	47.3	21424	14.1	55089	-20.8	169824
102.3	5539	46.6	21795	13.6	55979	-21.5	174200
100.6	5743	46.0	22171	13.1	56887	-22.3	178762
99.1	5949	45.4	22551	12.5	57811	-23.0	183522
97.6	6157	44.7	22936	12.0	58754	-23.8	188493
96.1	6367	44.1	23326	11.5	59715	-24.6	193691
94.7	6578	43.5	23720	11.0	60694	-25.4	199130
93.3	6792	42.9	24120	10.4	61693	-26.2	204829
92.0	7007	42.3	24525	9.9	62712	-27.0	210805
90.6	7225	41.7	24934	9.3	63752	-27.8	217080
89.4	7444	41.1	25349	8.8	64812	-28.7	223677
88.1	7666	40.5	25769	8.3	65895	-29.5	230621
86.9	7890	39.9	26195	7.7	67000	-30.4	237941
85.7	8115	39.3	26626	7.2	68128	-31.3	245667
84.5	8343	38.7	27063	6.7	69281	-32.2	253834
83.4	8573	38.1	27505	6.1	70458	-33.2	262482
82.3	8806	37.5	27954	5.6	71661	-34.1	271655
81.2	9040	37.0	28408	5.0	72890	-35.1	281400
80.1	9277	36.4	28868	4.5	74147	-36.1	291774
79.0	9516	35.8	29335	3.9	75431	-37.1	302840
78.0	9757	35.2	29808	3.4	76745	-38.2	314669
77.0	10001	34.7	30288	2.8	78090	-39.2	327343
76.0	10247	34.1	30774	2.3	79465		
75.0	10496	33.5	31267	1.7	80873		
74.1	10747	33.0	31766	1.2	82314		
73.1	11000	32.4	32273	0.6	83790		
72.2	11256	31.9	32787	0.0	85302		
71.3	11515	31.3	33309	-0.5	86852		
70.4	11776	30.7	33837	-1.1	88440		
69.5	12040	30.2	34374	-1.7	90068		
68.6	12306	29.6	34918	-2.2	91738		
67.7	12575	29.1	35471	-2.8	93452		
66.9	12847	28.6	36031	-3.4	95211		
66.0	13122	28.0	36600	-4.0	97016		
65.2	13400	27.5	37177	-4.6	98870		
64.4	13681	26.9	37764	-5.2	100775		
63.6	13964	26.4	38359	-5.7	102733		
62.8	14251	25.8	38963	-6.3	104746		
62.0	14540	25.3	39577	-6.9	106817		
61.2	14833	24.8	40200	-7.5	108948		
60.5	15129	24.2	40833	-8.2	111141		
59.7	15428	23.7	41476	-8.8	113400		
59.0	15730	23.2	42130	-9.4	115727		
58.2	16036	22.6	42794	-10.0	118126		
57.5	16345	22.1	43468	-10.6	120600		

**ERROR CODES:**

**TABLE 18. Outdoor Control 7-Segment Display Alert Codes – Outdoor Control Errors**

*NOTE - System fault and lockout codes take precedence over system status codes (cooling, heating operating percentages or defrost/dehumidification). Only the latest active fault or lockout codes are displayed (if present). If no fault or lockout codes are active, then system status codes are displayed. Alert codes are also displayed on the S40 thermostat.*

Alert Codes	Priority	Alarm Description	Possible Causes and Clearing Alarm
E 180	Service Soon / Service Urgent	The S40 thermostat has found a problem with the outdoor unit's ambient temperature sensor.	During normal operation, after the outdoor control recognizes sensors, the alarm will be sent only if valid temperature reading is lost. Compare outdoor sensor resistance to temperature/resistance charts in unit installation instructions. Replace sensor pack if necessary. At the beginning of (any) configuration, furnace or air-handler control will detect the presence of the sensor(s). If detected (reading in range), appropriate feature will be set as 'installed' and shown in the S40 thermostat 'About' screen. The alarm / fault will clear upon configuration, or sensing normal values.
E 182	Service Soon	Suction Temperature Sensor has malfunctioned	Sensor is open or shorted. Replace the Sensor
E 183	Service Soon	Liquid Pressure Transducer Fault	Liquid pressure transducer is out of range. The signal should be between 0.5 VDC and 4.5 VDC between Blue and Black. The error code will be cleared when the proper signal is provided. Systems controlled by a conventional 24VAC heat pump thermostat will operate in stage mode.
E 184	Service Soon	Faulty outdoor liquid line sensor	Sensor is open or shorted. Replace the sensor.

**DC Inverter Control Operation, Checkout, Status / Error Codes**

**OPERATION OF COMPONENTS:**

Electromagnetic compatibility circuit (EMC): EMC ensures the correct operation of different equipment items which use or respond to electromagnetic phenomena. It also helps to negate the effects of interference.

**CONVERTER:**

Converts AC (alternating current) to DC (direct current).

**POWER FACTOR CORRECTION (PFC) CIRCUIT:**

The PFC module is an integrated part of the outdoor inverter that monitors the DC bus for high, low and abnormal voltage conditions. If any of these conditions are detected, the PFC function and compressor will stop.

**INTELLIGENT (INVERTER) POWER MODULE (IPM):**

The IPM converts DC power into AC power. The control method is known as pulse width modulation (PWM). This means the DC is switched on and off very quickly (chopped) by the transistor switches to make simulated AC at required frequency and voltage.

**COMMUNICATION CONTROL CIRCUIT:**

Receives and sends message between the inverter and the outdoor control.

**STATUS CODES:**

**TABLE 19. Outdoor Control 7-Segment Display Alert Codes and Inverter LED Flash Codes**

*NOTE - System fault and lockout codes take precedence over system status codes (cooling, heating operating percentages or defrost/dehumidification). Only the latest active fault or lockout codes are displayed (if present). If no fault or lockout codes are active, then system status codes are displayed. Alert codes are also displayed on the S40 thermostat.*

Alert Codes	Inverter LED Flash Code (number of flashes)		Priority	Alarm Description	Possible Causes and Clearing Alarm
	Red LED	Green LED			
N/A	ON	OFF	N/A	EL19KPV-024, -036 only: Indicates inverter is operating normally.	
N/A	ON	ON	N/A	EL19KPV-048, -060 only: Indicates inverter is operating normally.	
N/A	OFF	OFF	N/A	Indicates inverter is NOT energized.	



**ERROR CODES:**

**TABLE 20. Outdoor Control 7-Segment Display Alert Codes and Inverter LED Flash Codes**

*NOTE - System fault and lockout codes take precedence over system status codes (cooling, heating operating percentages or defrost/dehumidification). Only the latest active fault or lockout codes are displayed (if present). If no fault or lockout codes are active, then system status codes are displayed. Alert codes are also displayed on the S40 thermostat.*

Alert Codes	Inverter Code	Inverter LED Flash Code (number of flashes)		Priority	Alarm Description	Possible Causes and Clearing Alarm
		Red LED	Green LED			
E 423	40	4 flashes	OFF	Service Soon / Service Urgent	The inverter has detected a circuit problem.	Control will lock out after 10 strikes within an hour. To clear, disconnect power to the indoor unit (24VAC power source to the outdoor control) which will power off the outdoor control and will open the outdoor unit contactor, which interrupts power to the inverter and then re-apply power.
E 427	21	2 flashes	1 flash	Service Soon / Service Urgent	The inverter has detected a DC peak fault condition.	If condition (55A or higher) is detected, outdoor unit will stop (compressor and fan). Antishort cycle is initiated. If peak current (55A or higher) occurs 10 times within an hour, system will lock out. Indicates high pressure, condenser fan failure, locked compressor rotor or overcharge. To clear, disconnect power to the indoor unit (24VAC power source to the outdoor control) which will power off the outdoor control and will open the outdoor unit contactor, which interrupts power to the inverter and then re-apply power.
E 428	22	2 flashes	2 flashes	Service Soon / Service Urgent	The inverter has detected a high main input current condition	If condition is detected, outdoor unit will stop (compressor and fan). Antishort cycle is initiated. If condition occurs 5 times within an hour, the unitary control will cycle the contactor to prevent the unit from locking out. Indicates high pressure, condenser fan failure or overcharge. To clear, disconnect power to the indoor unit (24VAC power source to the outdoor control) which will power off the outdoor control and will open the outdoor unit contactor, which interrupts power to the inverter and then re-apply power.
E 429	23	2 flashes	3 flashes	Service Soon / Service Urgent	On a call for compressor operation, if DC link power in inverter does not rise above 180 VDC for 2 and 3 ton models, 250 VDC for 4 and 5 ton models, within 30 seconds, the control will display a moderate code. If condition is detected, outdoor unit will stop (Compressor and fan). Antishort cycles is initiated. If condition occurs 10 times within a 60 minute rolling time period, system will lock out and display a critical code.	<b>Issues:</b> (1) If DC link power in inverter does not rise above 180 VDC for 2- and 3-ton models, 250 VDC for 4- and 5-ton models, within 30 seconds, the outdoor control will display a moderate code. (2) Capacitors on inverter do not properly charge. <b>Corrective Actions:</b> (1) Check for proper main power to outdoor unit and for any loose electrical connections.
E 430	26	2 flashes	6 flashes	Service Soon / Service Urgent	Compressor start failure.	If condition is detected, outdoor unit will stop (compressor and fan). Antishort cycle is initiated. If condition occurs 10 times within an hour, system will lock out. Indicates poor connection at compressor harness, improper winding resistance, locked compressor rotor, or flooded compressor. To clear, disconnect power to the indoor unit (24VAC power source to the outdoor control) which will power off the outdoor control and will open the outdoor unit contactor, which interrupts power to the inverter and then re-apply power.

**TABLE 20. Outdoor Control 7-Segment Display Alert Codes and Inverter LED Flash Codes**

NOTE - System fault and lockout codes take precedence over system status codes (cooling, heating operating percentages or defrost/dehumidification). Only the latest active fault or lockout codes are displayed (if present). If no fault or lockout codes are active, then system status codes are displayed. Alert codes are also displayed on the S40 thermostat.

Alert Codes	Inverter Code	Inverter LED Flash Code (number of flashes)		Priority	Alarm Description	Possible Causes and Clearing Alarm
		Red LED	Green LED			
E 431	27	2 flashes	7 flashes	Service Soon / Service Urgent	Error occurs when PFC detects an over-current condition of 100A, the control will display a moderate code. If condition is detected, outdoor unit will stop (Compressor and fan). Anti-short cycle is initiated. Inverter is unavailable to communicate with the outdoor control for 3 minutes. If condition occurs 10 times within a 60 minute rolling time period, system will lock out and display a critical code.	<p><b>Issues:</b></p> <p>(1) Indicates power interruption, brownout, poor electrical connection or loose inverter input wire.</p> <p>(2) System testing was set up and code was generated when the reversing valve is de-energized coming out of defrost (code appears with or without 30 compressor delay).</p> <p><b>Corrective Actions:</b></p> <p>(1) Check for proper main power to outdoor unit and for any loose electrical connections.</p>
E 432	28	2 flashes	8 flashes	Service Soon / Service Urgent	The inverter has detected a DC link high voltage condition.	Error occurs when the DC link capacitor voltage is greater than 480VDC. If condition is detected, outdoor unit will stop (compressor and fan). Antishort cycle is initiated. If condition occurs 10 times within an hour, system will lock out. System will stop. To clear, disconnect power to the indoor unit (24VAC power source to the outdoor control) which will power off the outdoor control and will open the outdoor unit contactor, which interrupts power to the inverter and then re-apply power.
E 433	29	2 flashes	9 flashes	Service Soon / Service Urgent	The inverter has detected a compressor over-current condition	Error occurs when compressor peak phase current is greater than 28A. Inverter will issue code 14 first and slow down to try to reduce the current. If the current remains high, outdoor unit will stop (compressor and fan). Antishort cycle is initiated. If condition occurs 5 times within an hour, the unitary control will cycle the contactor to prevent the unit from locking out. To clear, disconnect power to the indoor unit (24VAC power source to the outdoor control) which will power off the outdoor control and will open the outdoor unit contactor, which interrupts power to the inverter and then re-apply power.
E 434	53	5 flashes	3 flashes	Service Soon / Service Urgent	Outdoor control has lost communications with the inverter for greater than 3 minutes. Outdoor unit will stop all compressor demand. Outdoor control will attempt to establish communication multiple times and will automatically clear when the error clears. Unit will lock out after 60 minutes if communication is not established and will display a critical error code.	<p><b>Issues:</b></p> <p>(1) Outdoor disconnect is off or outdoor power is off, when indoor power is on (source for 24VAC)</p> <p>(2) Loose electrical power connections</p> <p>(3) Interruption of main power to the inverter</p> <p>(4) Generator powers indoor unit, but not the outdoor unit.</p> <p><b>Corrective Actions:</b></p> <p>(1) To reset, cycle the indoor power off (source of 24VAC to outdoor unit) and back on. This will de-energize outdoor control and inverter by cycling the contactor.</p> <p>(2) Make sure the disconnect is on</p> <p>(3) Check electrical power supply connections</p> <p>(4) Check for proper main 230V power supply</p>
E 435	60	6 flashes	OFF	Service Soon / Service Urgent	Inverter internal error.	When this error occurs, the outdoor control will cycle power to the inverter by opening the contactor for 2 minutes. Check that the EEPROM is properly seated. After power is cycled to the inverter 3 times, the outdoor unit is locked out.

**TABLE 20. Outdoor Control 7-Segment Display Alert Codes and Inverter LED Flash Codes**

*NOTE - System fault and lockout codes take precedence over system status codes (cooling, heating operating percentages or defrost/dehumidification). Only the latest active fault or lockout codes are displayed (if present). If no fault or lockout codes are active, then system status codes are displayed. Alert codes are also displayed on the S40 thermostat.*

Alert Codes	Inverter Code	Inverter LED Flash Code (number of flashes)		Priority	Alarm Description	Possible Causes and Clearing Alarm
		Red LED	Green LED			
E 436	62	6 flashes	2 flashes	Service Soon / Service Urgent	<p>Inverter heat sink temperature exceeded limit. Occurs when the heat sink temperature exceeds the inverter limit. Inverter issues code 13 first, then slows down to allow the heat sink to cool. If temperature remains high, outdoor unit stops (compressor and fan). Anti-short cycle is initiated. If condition occurs 5 times within an hour, the unitary control will cycle the contactor to prevent the unit from locking out.</p> <p>To clear, disconnect power to the indoor unit (24VAC power source to the outdoor control) which will power off the outdoor control and will open the outdoor unit contactor, which interrupts power to the inverter and then re-apply power.</p>	<p><b>Issue:</b> Feedback from supplier tear down of inverter indicates that the screws that hold the inverter to the inverter board were loose causing poor contact between these two components.</p> <p><b>Corrective Action:</b> Tighten screws that hold the heat sink to the inverter control board.</p> <p><b>NOTE:</b> Wait five minutes to all capacitor to discharge before checking screws.</p>
E 437	65	6 flashes	5 flashes	Service Soon / Service Urgent	<p>Heat sink temperature sensor fault has occurred (temperature less than 4 °F or greater than 264°F after 10 minutes of operation).</p>	<p>This occurs when the temperature sensor detects a temperature less than 0.4°F or greater than 264°F after 10 minutes of operation. If condition is detected, outdoor unit will stop (compressor and fan). Antishort cycle is initiated. If condition occurs 5 times within an hour, the unitary control will cycle the contactor to prevent the unit from locking out.</p> <p>To clear, disconnect power to the indoor unit (24VAC power source to the outdoor control) which will power off the outdoor control and will open the outdoor unit contactor, which interrupts power to the inverter and then re-apply power.</p>
E 438	73	7 flashes	3 flashes	Service Soon / Service Urgent	<p>The inverter has detected a PFC over current condition. This would be caused by a high load condition, high pressure, or outdoor fan failure. Outdoor control will display the code when the inverter has the error. After 3 minutes, the inverter will reset and the compressor will turn on again. If it happens 10 times within a 60 minute rolling time period, the OD control will lock out operation of the outdoor unit and display a critical code.</p>	<p><b>Issue:</b> Possible issue is system running at high pressures. Check for high pressure trips or other alert codes in room thermostat and outdoor control.</p> <p>To clear, disconnect power to the indoor unit (24VAC power source to the outdoor control) which will power off the outdoor control and will open the outdoor unit contactor, which interrupts power to the inverter and then re-apply power.</p>
E 439	12	1 flash	2 flashes	Information Only / Dealer	<p>Compressor slowdown due to high input current.</p>	<p>This error code is primarily for informational purposes as the inverter controls the compressor to operate within design parameters. Typically the inverter will make a minor speed reduction of 4 Hz (approximately a 5-6% speed reduction) for a brief period of time and to reduce the input current and will then resume normal operation.</p>

**TABLE 20. Outdoor Control 7-Segment Display Alert Codes and Inverter LED Flash Codes**

*NOTE - System fault and lockout codes take precedence over system status codes (cooling, heating operating percentages or defrost/dehumidification). Only the latest active fault or lockout codes are displayed (if present). If no fault or lockout codes are active, then system status codes are displayed. Alert codes are also displayed on the S40 thermostat.*

Alert Codes	Inverter Code	Inverter LED Flash Code (number of flashes)		Priority	Alarm Description	Possible Causes and Clearing Alarm
		Red LED	Green LED			
E 440	13	1 flash	3 flashes	Information Only / Dealer	Heat sink temperature is approaching limit. The compressor speed automatically slows to reduce heat sink temperature. The control sets indoor CFM and outdoor RPM to values according to demand percentage rather than the actual Hz. Alarm is automatically cleared.	<p>This error code is primarily for informational purposes as the inverter controls the compressor speed to operate within design parameters. Typically the inverter will make a minor speed reduction of 4 Hz (approximately a 5-6% speed reduction) for a brief period of time and to reduce the heat sink temperature and will then resume normal operation. This may occur at high outdoor temperatures (above 110°F) for brief periods of time (3 – 4 minutes) and is normal and expected operation of the inverter controlling the compressor safely within design parameters.</p> <p>The inverter finned aluminum heat sink is located on the back side of the inverter in the condenser air stream. If the alert code 440 occur frequently, especially at lower outdoor temperatures, check the heat sink for debris that may reduce heat transfer or possible obstructions that may impact air flow across the heat sink.</p> <p>The inverter will begin to briefly reduce the compressor speed when the heat sink temperature rises above 167°F and will allow the inverter to resume the requested compressor demand speed once the inverter heat sink reaches 150°F. The heat sink temperature, compressor speed in Hertz the Inverter Compressor Speed Reduction status ("On" or "Off ") notification can be viewed under the outdoor unit Diagnostics section of the thermostat dealer control center on units installed with an S40 thermostat.</p>
E 441	14	1 flash	4 flashes	Information Only / Dealer	Compressor slowdown due to high compressor current. Compressor current is approaching limit. The compressor speed automatically slows. The control sets indoor CFM and outdoor RPM to values according to demand percentage rather than the actual Hz. Alarm is automatically cleared..	<p>This error code is primarily for informational purposes as the inverter controls the compressor to operate within design parameters. Alert code 441 typically occurs at startup as the compressor as the currently increases rapidly during startup.</p> <p>The inverter will reduce the compressor speed by 4 hz and slow the compressor ramp up speed to the requested compressor demand (capacity). This is normal and expected operation of the inverter to control the compressor within design parameters. In most cases the alert code 441 does not require any additional service or diagnostic procedures.</p> <p>E441 may also occur if the system is operating at high pressures.</p> <p>This error code is primarily for informational purposes as the inverter controls the compressor to operate within design parameters. Alert code 441 typically occurs at startup as the compressor as the currently increases rapidly during startup.</p> <p>The inverter will reduce the compressor speed by 4 hz and slow the compressor ramp up speed to the requested compressor demand (capacity). This is normal and expected operation of the inverter to control the compressor within design parameters. In most cases the alert code 441 does not require any additional service or diagnostic procedures.</p> <p>E441 may also occur if the system is operating at high pressures.</p>

## System Refrigerant

### **IMPORTANT**

The system must be operating at full capacity during charging. Using the Charge Mode Jumper on the outdoor control ensures the unit is running at 100% capacity. Confirm outdoor unit running capacity.

This section outlines the procedures to:

- 1 - Connect a gauge set for testing and charging as illustrated in figure 48.
- 2 - Check and adjust indoor airflow as described in figure 49.
- 3 - Add or remove refrigerant using the weigh-in method shown in figure 50.
- 4 - Verify the charge using the subcooling method described in figure 51.

**IMPORTANT:** Unit must be operating at 100% capacity to be charged properly.

### **ADDING OR REMOVING REFRIGERANT**

This system uses R454B refrigerant which operates at slightly lower pressures than R-410A.

This system uses R454B refrigerant, which is a zeotropic blend. Unit must be charged with liquid refrigerant only.

### **INDOOR AIRFLOW CHECK**

Check airflow using the Delta-T (DT) process using the illustration in figure 49.

The diagnostic screen on the S40 thermostat displays the indoor CFMs on systems installed with the S40 communicating thermostat.

On systems installed with the S40 thermostat, the Cooling - Maximum Rate Test located in the Test section of the Dealer Control Center of the thermostat or the Dealer Setup App may be used to operate the unit at maximum capacity during charging.

## Charge Mode Jumper

To initiate the EL19KPV Charge Mode function, install the jumper across the two Charge Mode Pins (CHRG MODE) on the outdoor control. The Charge Mode can be used when charging the system with refrigerant, checking the refrigerant charge, pumping down the system and performing other service procedures that requires outdoor unit operation at 100% capacity.

### **EL19KPV Charge Mode Operation with a S40 Communicating Thermostat**

Installing a jumper on the Charge Mode Pins will initiate compressor operation in the cooling mode and outdoor fan motor at 100% capacity and will provide a signal to the indoor unit to initiate indoor blower operation at the maximum cooling air volume. To exit the charge mode, remove the Charge Mode Jumper. The Charge Mode has a maximum time of 60 minutes and will automatically exit the charge mode after 60 minutes is the charge mode jumper is left in place.

### **EL19KPV Charge Mode Operation with a Conventional 24VAC Non-Communicating Heat Pump Thermostat**

On applications with a conventional 24VAC non-communicating thermostat, the charge mode jumper must be installed on the Charge Mode Pins after providing a Y1 compressor demand to the EL19KPV to initiate the Charge Mode. When using the Charge Mode in the cooling mode, the "O" must also be provided with a 24V signal to place the reversing valve in the cool position. In the heating mode only a Y1 compressor demand is required along with the blower demand for the full cooling air volume. A cooling blower demand must also be provided to initiate blower operation on the cooling speed on the indoor unit. The compressor and outdoor fan motor will operate at 100% capacity. To exit the charging mode, remove the Charge Mode Jumper and remove the Y1 Cooling demand and indoor blower demand. The Charge Mode has a maximum time of 60 minutes and will automatically exit the charge mode after 60 minutes is the charge mode jumper is left in place.

## Charging

Verify the unit is electrically grounded before charging the system. Extreme care shall be taken not to overfill the refrigerating system.

Charge should be checked and adjusted using information outlined in this section and in the tables provided on the charging label on the unit's control access panel.

R454B is a zeotropic blend of two refrigerants. At any given refrigerant pressure, R454B will have two saturation temperatures, a saturated liquid temperature and a saturated vapor temperature. See R454B Refrigerant Pressure Temperature Chart in the installation and service manual for saturation temperatures.

R454B Units must be charged with liquid refrigerant. Follow conventional charging procedures when charging the system. The technician is required to mark the total charge of the installed system on the unit nameplate, which includes the nameplate charge (factory charge) and additional charge that is added to the system at the time of installation.

The R454B refrigerant cylinders are provided with a ¼" LH flare connection, therefore a ¼" LH female flare adapter will be required. Connect manifold gauges and hoses following conventional charging procedures. Position the R454B refrigerant cylinder to deliver liquid refrigerant.

EL19KPV unit is factory charged with R454B. Refer to unit Charging Label for baseline line set length for factory unit charge and Additional Charge guidelines.

Initiate a call for cooling and allow the refrigerant pressures and temperatures to stabilize. Adjust the charge to using the subcooling method. The unit charging label provides the target Subcooling Values. Record the liquid line temperature. Measure the liquid line pressure and use the value to determine the Saturated Liquid Temperature. Calculate subcooling by subtracting the liquid line temperature from the Saturated liquid temperature.

Subcooling = Saturated Liquid Temperature – Liquid Line Temperature

Compare the results with the unit charging label.

Once system charging has been completed, the additional charge and total charge must be marked on the unit nameplate. Total Charge = Factory Charge + Additional charge. The total charge is marked on the space adjacent to "Total Charge". See nameplate below.

Detailed information is given in the EL19KPV Installation and Service Procedures manual, which is available on LennoxPros.com.

### Refrigerant Charge per Line Set Length

LIQUID LINE DIA.	OUNCES PER 5 FEET (G PER 1.5 M) ADJUST FROM 15 FEET (4.6 M) LINE SET*
3/8" (9.5 MM)	3 OUNCES PER 5' (85 G PER 1.5 M)

\*If line length is greater than 15 ft. (4.6 m), add this amount. If line length is less than 15 ft. (4.6 m), subtract this amount.

NOTE – Insulate liquid line when it is routed through areas where the surrounding ambient temperature could become higher than the temperature of the liquid line or when pressure drop is equal to or greater than 20 psig.

[ ]		[ ]	
M/N [ ]		MFG: Month/Year	
S/N [ ]		MFG: Month/Year	
CONTAINS R-454B	MAXIMUM ALLOWABLE PRESSURE		
FACTORY CHARGE	640 PSIG (4412.8 kPa)		
xx LBS xx OZS (X.X kg)	[ ]		
TOTAL CHARGE	[ ]		
ELECTRICAL RATING		NOMINAL VOLTS 208/230	
1 PH	60 HZ	MIN 197	MAX 253

Additional Charge added to bring system to full charge (Line Set Length / Coil matches)

Total System Charge (Factory Charge + Additional Charge)

(NOTE - The nameplate is shown for illustration purposes only. Go to actual nameplate on outdoor unit for charge information.)

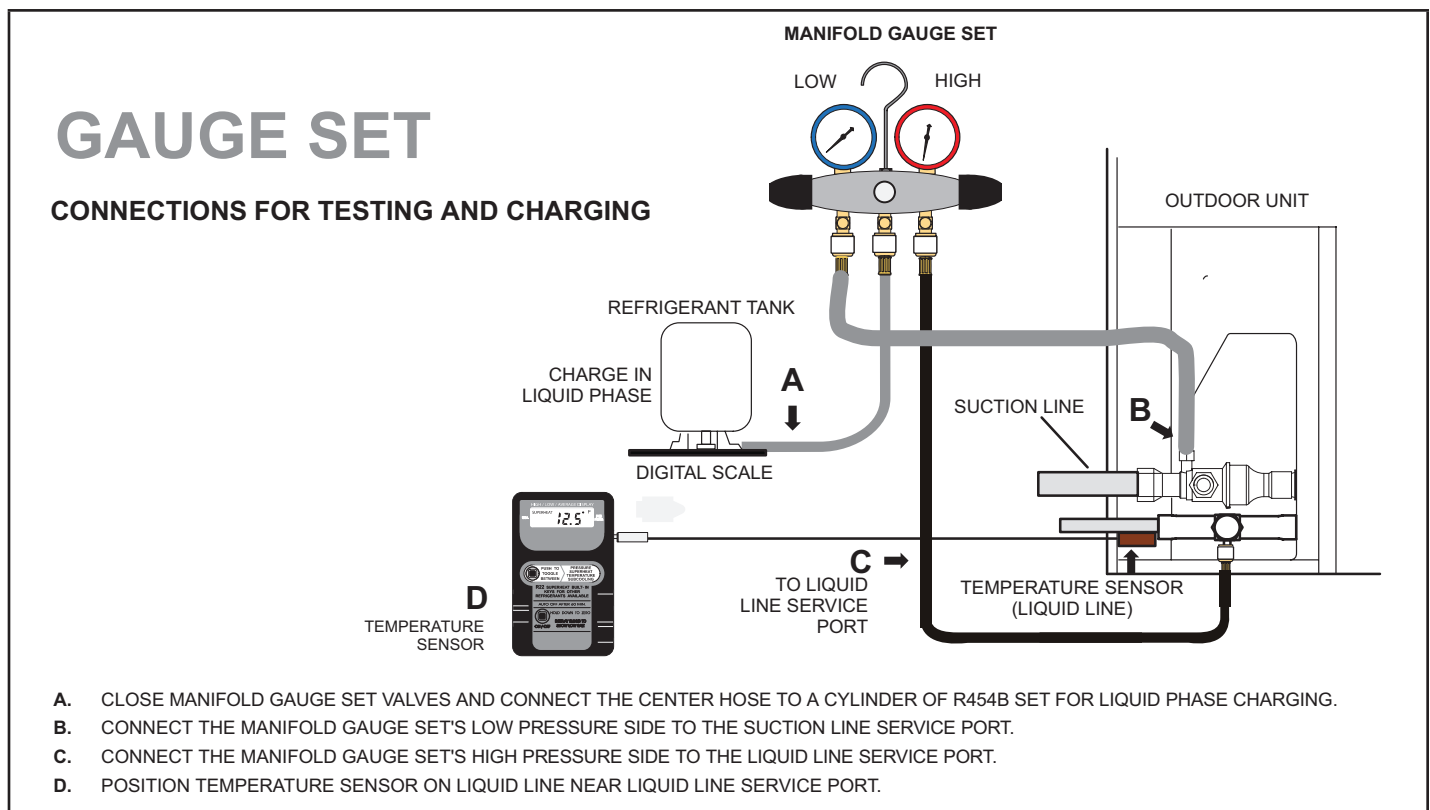
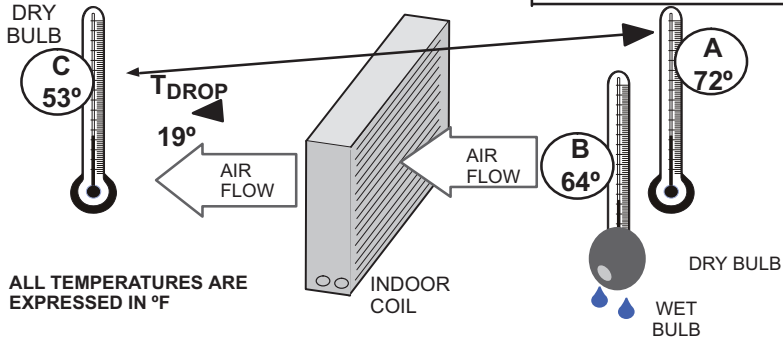


FIGURE 48. Gauge Set Connections

# AIRFLOW INDOOR COIL



ALL TEMPERATURES ARE EXPRESSED IN °F

ASSUME DT = 15 AND A TEMP. = 72°, BELOW C TEMPERATURES REQUIRE ACTION:

C°	T <sub>DROP</sub>	-	DT	=	°F	ACTION
53°	19	-	15	=	4	INCREASE THE AIRFLOW
58°	14	-	15	=	-1	(WITHIN ±3° RANGE) NO CHANGE
62°	10	-	15	=	-5	DECREASE THE AIRFLOW

		DT															
TEMPERATURE OF AIR ENTERING INDOOR COIL °F		80	78	76	74	72	70	24	23	22	21	20	19	18	17	16	15
A	WET-BULB °F	DRY-BULB															
		57	58	59	60	61	62	63	64	65	66	67	68	69	70		

1. DETERMINE THE DESIRED DT — MEASURE ENTERING AIR TEMPERATURE USING DRY BULB (A) AND WET BULB (B). DT IS THE INTERSECTING VALUE OF A AND B IN THE TABLE (SEE TRIANGLE).
  2. FIND TEMPERATURE DROP ACROSS COIL — MEASURE THE DRY BULB AIR TEMPERATURE ENTERING AND LEAVING THE COIL (A AND C). TEMPERATURE DROP FORMULA: (T<sub>DROP</sub>) = A MINUS C.
  3. DETERMINE IF FAN NEEDS ADJUSTMENT — IF THE DIFFERENCE BETWEEN THE MEASURED T<sub>DROP</sub> AND THE DESIRED DT (T<sub>DROP</sub>-DT) IS WITHIN ±3°, NO ADJUSTMENT IS NEEDED. SEE EXAMPLE AT LEFT.
  4. ADJUST THE FAN SPEED — SEE INDOOR UNIT INSTRUCTIONS TO INCREASE/DECREASE FAN SPEED.
- NOTE - CHANGING AIR FLOW AFFECTS ALL TEMPERATURES; RECHECK TEMPERATURES TO CONFIRM THAT THE TEMPERATURE DROP AND DT ARE WITHIN ±3°.


FIGURE 49. Checking Indoor Airflow over Evaporator Coil using Delta-T Chart

Use the WEIGH-IN method for adding initial refrigerant charge, and then use SUBCOOLING method for verifying refrigerant charge.

## WEIGH-IN CHARGING METHOD

64°F (17.7°C) and Below

Amount specified on nameplate



Adjust amount for variation in line set length and liquid line diameter using table below.

Liquid Line Set Diameter	R454B (ounces per foot)
5/16"	0.40
3/8"	0.60
1/2"	1.00

Total charge

± \_\_\_\_\_ = \_\_\_\_\_

**NOTE** - Insulate liquid line when it is routed through areas where the surrounding ambient temperature could become higher than the temperature of the liquid line or when pressure drop is equal to or greater than 20 psig.

**NOTE** - The nameplate is shown for illustration purposes only. Go to actual nameplate on outdoor unit for charge information.

**Charging Formula for Liquid Line Charge Adjustments**

[(Line set oz./ft. x total length) - (factory charge for line set)] = charge adjustment

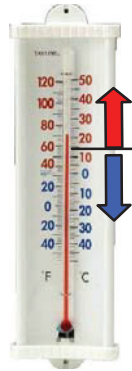
**Example:** Units are factory-charged for 15 feet (4.6 meters) of 3/8" line set. Factory charge for 3/8" is 0.60 oz/ft x 15 = 9.0 ounces.

**FIGURE 50. Using R454B Weigh-In Method**

## SUBCOOLING CHARGING METHOD

(All charging **MUST** be performed while system is operating either at maximum speed or 100% demand.)

1. THE DIAGNOSTIC SCREEN ON THE THERMOSTAT OR OUTDOOR CONTROL 7-SEGMENT DISPLAY WILL SHOW INDOOR AND OUTDOOR MOTOR CFMS OR RPMS.
2. MEASURE OUTDOOR AMBIENT TEMPERATURE.
3. CONNECT GAUGE SET.
4. CHECK LIQUID AND VAPOR LINE PRESSURES. COMPARE PRESSURES WITH COOLING MODE NORMAL OPERATING PRESSURES IN THE APPLICABLE CHARGING STICKER, NORMAL OPERATING PRESSURES AT MAXIMUM CAPACITY.



USE COOLING MODE  
60°F (15°C)  
USE HEATING MODE

**NOTE** - THE REFERENCE TABLE IS A GENERAL GUIDE. EXPECT MINOR PRESSURE VARIATIONS. SIGNIFICANT DIFFERENCES MAY MEAN IMPROPER CHARGE OR OTHER SYSTEM PROBLEM.

5. SET THERMOSTAT FOR HEAT/COOL DEMAND, DEPENDING ON MODE BEING USED:

**USING COOLING MODE** — WHEN THE OUTDOOR AMBIENT TEMPERATURE IS 60°F (15°C) AND ABOVE. TARGET SUBCOOLING VALUES (MAXIMUM / 100% CAPACITY) IN APPLICABLE CHARGING STICKER ARE BASED ON 70 TO 80°F (21-27°C) INDOOR RETURN AIR TEMPERATURE; IF NECESSARY, OPERATE HEATING TO REACH THAT TEMPERATURE RANGE; THEN SET THE INITIAL COOLING DEMAND AT MAXIMUM CAPACITY. THE PREFERRED METHOD IS TO USE THE "CHARGE MODE" JUMPER ON THE OUTDOOR CONTROL. SEE CHARGE MODE JUMPER SECTION ON PAGE 80. WHEN PRESSURES HAVE STABILIZED, CONTINUE WITH STEP 6.

6. READ THE LIQUID LINE TEMPERATURE; RECORD IN THE LIQ° SPACE.
7. READ THE LIQUID LINE PRESSURE; THEN FIND ITS CORRESPONDING TEMPERATURE IN THE TEMPERATURE/ PRESSURE CHART LISTED IN THE APPLICABLE CHARGING STICKER AND RECORD IT IN THE SAT° SPACE.
8. SUBTRACT LIQ° TEMPERATURE FROM SAT° TEMPERATURE TO DETERMINE SUBCOOLING; RECORD IT IN SC° SPACE.
9. COMPARE SC° RESULTS WITH APPLICABLE CHARGING STICKER, BEING SURE TO NOTE ANY ADDITIONAL CHARGE FOR LINE SET AND/OR MATCH-UP.
10. IF SUBCOOLING VALUE IS GREATER THAN SHOWN IN APPLICABLE CHARGING STICKER FOR THE APPLICABLE UNIT, REMOVE REFRIGERANT; IF LESS THAN SHOWN, ADD REFRIGERANT.
11. IF REFRIGERANT IS ADDED OR REMOVED, REPEAT STEPS 6 THROUGH 10 TO VERIFY CHARGE.
12. DISCONNECT GAUGE SET AND RE-INSTALL BOTH THE LIQUID AND SUCTION SERVICE VALVE CAPS.

SAT° \_\_\_\_\_

LIQ° - \_\_\_\_\_

SC° = \_\_\_\_\_

**FIGURE 51. Using R454B Subcooling Method - High Speed (High Capacity)**



TABLE 21. R454B Temperature (°F) - Pressure (Psig)

Pressure (psig)	Saturated Liquid Temp (°F)	Saturated Vapor Temp (°F)	Pressure (psig)	Saturated Liquid Temp (°F)	Saturated Vapor Temp (°F)	Pressure (psig)	Saturated Liquid Temp (°F)	Saturated Vapor Temp (°F)	Pressure (psig)	Saturated Liquid Temp (°F)	Saturated Vapor Temp (°F)
0	-58.9	-57.1	158	58.9	61.3	272	93.0	95.4	362	113.4	115.6
25	-19.2	-17.2	160	59.6	62.0	274	93.5	95.9	364	113.8	116.0
30	-13.9	-11.8	165	61.4	63.8	276	94.0	96.4	366	114.2	116.4
35	-9.0	-6.9	170	63.1	65.5	278	94.5	96.9	368	114.6	116.8
40	-4.4	-2.3	175	64.9	67.3	280	95.0	97.4	370	115.0	117.2
45	-0.2	1.9	180	66.6	69.0	282	95.5	97.9	372	115.4	117.6
50	3.7	5.9	185	68.2	70.6	284	96.0	98.4	374	115.8	118.0
55	7.5	9.7	190	69.8	72.2	286	96.5	98.8	376	116.2	118.4
60	11.0	13.2	195	71.4	73.8	288	97.0	99.3	378	116.6	118.8
65	14.4	16.6	200	73.0	75.4	290	97.5	99.8	380	117.0	119.2
70	17.6	19.8	202	73.6	76.0	292	97.9	100.3	382	117.4	119.6
75	20.6	22.9	204	74.2	76.6	294	98.4	100.7	384	117.7	119.9
80	23.6	25.9	206	74.9	77.3	296	98.9	101.2	386	118.1	120.3
85	26.4	28.7	208	75.5	77.9	298	99.4	101.7	388	118.5	120.7
90	29.1	31.4	210	76.1	78.5	300	99.8	102.2	390	118.9	121.1
95	31.7	34.0	212	76.7	79.1	302	100.3	102.6	392	119.3	121.5
100	34.3	36.6	214	77.3	79.7	304	100.8	103.1	394	119.7	121.9
102	35.3	37.6	216	77.9	80.2	306	101.2	103.5	396	120.1	122.2
104	36.2	38.6	218	78.4	80.8	308	101.7	104.0	398	120.5	122.6
106	37.2	39.5	220	79.0	81.4	310	102.1	104.4	400	120.8	123.0
108	38.1	40.5	222	79.6	82.0	312	102.6	104.9	405	121.8	123.9
110	39.1	41.4	224	80.2	82.6	314	103.0	105.4	410	122.7	124.9
112	40.0	42.4	226	80.8	83.1	316	103.5	105.8	415	123.6	125.8
114	40.9	43.3	228	81.3	83.7	318	103.9	106.2	420	124.6	126.7
116	41.8	44.2	230	81.9	84.3	320	104.4	106.7	425	125.5	127.6
118	42.7	45.1	232	82.4	84.8	322	104.8	107.1	430	126.4	128.5
120	43.6	46.0	234	83.0	85.4	324	105.3	107.6	435	127.3	129.4
122	44.5	46.9	236	83.6	86.0	326	105.7	108.0	440	128.2	130.2
124	45.4	47.7	238	84.1	86.5	328	106.2	108.5	445	129.0	131.1
126	46.2	48.6	240	84.7	87.1	330	106.6	108.9	450	129.9	132.0
128	47.1	49.4	242	85.2	87.6	332	107.0	109.3	460	131.6	133.7
130	47.9	50.3	244	85.8	88.1	334	107.5	109.7	470	133.3	135.3
132	48.8	51.1	246	86.3	88.7	336	107.9	110.2	480	135.0	137.0
134	49.6	51.9	248	86.8	89.2	338	108.3	110.6	490	136.7	138.6
136	50.4	52.8	250	87.4	89.7	340	108.8	111.0	500	138.3	140.2
138	51.2	53.6	252	87.9	90.3	342	109.2	111.5	510	139.9	141.8
140	52.0	54.4	254	88.4	90.8	344	109.6	111.9	520	141.5	143.3
142	52.8	55.2	256	88.9	91.3	346	110.0	112.3	530	143.0	144.8
144	53.6	56.0	258	89.5	91.8	348	110.5	112.7	540	144.5	146.3
146	54.3	56.7	260	90.0	92.4	350	110.9	113.1	550	146.1	147.8
148	55.1	57.5	262	90.5	92.9	352	111.3	113.5	560	147.5	149.2
150	55.9	58.3	264	91.0	93.4	354	111.7	114.0	570	149.0	150.7
152	56.6	59.0	266	91.5	93.9	356	112.1	114.4	580	150.5	152.1
154	57.4	59.8	268	92.0	94.4	358	112.5	114.8	590	151.9	153.5
156	58.1	60.5	270	92.5	94.9	360	112.9	115.2	600	153.3	154.8

Note

1. R-454B is a zeotropic blend and must be charged with liquid refrigerant only.
2. Saturated liquid temperature is used to calculate liquid subcooling.
3. Saturated vapor temperature is used to calculate suction superheat.
4. See unit charging label for subcooling values and additional charging information.

**FIGURE 52. EL19KPV Charging Label**

**R454B CHARGING INFORMATION – FOR COMPLETE CHARGING DETAILS, REFER TO THE OUTDOOR UNIT INSTALLATION AND SERVICE PROCEDURE**

**Maintenance checks using the Normal Operating Pressures table**

Table 2 may be used to help perform maintenance checks. This table is not a procedure for charging the system and any minor variations in the pressures may be expected due to differences in installations. However, significant deviations could mean that the system is not properly charged or that a problem exists with some component in the system.

**Charge Using the Subcooling Method**

**Cooling Mode** – When the outdoor ambient temperature is 60°F (15°C) and above, use the cooling mode to adjust the charge using the subcooling method. Target subcooling values in table 1 are based on 70 to 80°F (21-27°C) indoor return air temperature.

**Heating Mode** – When the outdoor ambient temperature is below 60°F (15°C), use the heating mode to adjust the charge using the subcooling charge levels (table 1). Target subcooling values in table 1 are based on 65-75°F (18-24°C) indoor return air temperature.

**Matchups/Charge Levels and Line Set Lengths**

Table 2 lists all the Lennox recommended indoor unit matchups along with the charge levels for the various sizes of outdoor units. **Charge levels on the unit nameplate are based on installations with 30ft. (9.1m) line sets; on line sets with 3/8”(9.5mm) liquid line, add 3oz. additional refrigerant for every 5ft. longer than 30ft. If line length is less than 30ft., subtract this amount (see Installation Instructions for more details).**

**Charge Using the Weigh-in Method**

If the system is void of refrigerant, locate and repair any leaks and then weigh in the refrigerant charge into the unit. For charge adjustments, be sure to consider line set length differences and, referring to table 1, adjust for the matchup difference.

- 1 - Recover the refrigerant from the unit.
- 2 - Conduct leak check; evacuate as previously outlined.
- 3 - Weigh in the unit nameplate charge, adjusting for matchup and line set length differences. If weighing facilities are not available use the Subcooling method.

**Table 1 – Normal Operating Pressures (Liquid ±10 and Vapor ±5 psig)**

Temperature °F*	Cooling Operation – Liquid Line Pressure / Vapor Line Pressure			
	-024	-036	-048	-060
65	227/134	245/128	236/126	255/124
75	265/136	284/130	275/130	297/126
85	307/138	328/132	317/132	343/127
95	356/141	375/133	367/134	393/129
105	408/143	426/136	417/137	447/131
115	467/145	479/138	471/139	500/137
Temperature	Heating Operation – Liquid Line Pressure / Vapor Line Pressure			
	20	30	40	50
20	355/59	262/36	265/41	294/47
30	366/73	397/70	388/57	313/61
40	374/89	314/83	315/78	332/71
50	392/107	329/99	340/93	364/93
60	401/126	346/115	361/111	382/112

\*Temperature of air entering the outdoor coil.

**Table 2 – Indoor Unit Matches and Subcooling Charge Levels and Additional Charge\*\***

Indoor Matchup	Target Subcool		Total Charge		Additional Charge	
	Heating (±5°F)	Cooling (±1°F)	lbs	oz	lbs	oz
<b>EL19KPV-024</b>						
CBK45UH-024	35	14	10	1	1	2
CBK45UH-030	32	16	10	8	1	9
CBK48MVT-018/024 CBK47UH-024"	31	14	8	15	0	0
CBK48MVT-030 CBK47UH-030"	26	11	9	13	0	14
CK40(C,U)T-24	40	12	9	11	0	12
CK40(C,U)T-30	32	14	10	2	1	3
CK40(C,U)T-36	27	15	9	15	1	0
CK40HT-30A	34	15	10	4	1	5
CK40HT-30B	28	14	10	1	1	2
CK40DT-42B	57	13	9	15	1	0
<b>EL19KPV-036</b>						
CBK45UH-036	19	25	10	7	1	15
CBK45UH-042	18	25	10	14	2	6
CBK48MVT-036 CBK47UH-036"	16	14	8	11	0	3
CK40(C,U)T-30/36	61	16	8	8	0	0
CK40(C,U)T-36	20	11	9	15	1	7
CK40(C,U)T-48	21	27	10	7	1	15
CK40HT-36A	27	16	9	2	0	10
CK40HT-36C	20	17	9	0	0	8
CK40HT-42C	19	23	10	4	1	12
CK40HT-48B	23	28	11	2	2	10
CK40HT-48C	24	28	10	15	2	7
CK40DT-30/36B	48	17	8	14	0	6
CK40DT-42B	53	23	9	14	1	10
CK40DT-48C	50	26	10	8	2	0
<b>EL19KPV-048</b>						
CBK45UH-048	16	9	9	6	0	0
<b>EL19KPV-060</b>						
CBK45UH-060	20	14	10	7	0	9
CBK48MVT-060 CBK47UH-060"	21	19	12	8	2	10
CK40(C,U)T-48	32	14	10	5	0	7
CK40(C,U)T-49	21	14	11	3	1	5
CK40(C,U)T-50/60	22	13	9	14	0	0
CK40(C,U)T-60C	18	15	10	12	0	14
CK40(C,U)T-60D	12	12	11	3	1	5
CK40HT-48C	31	14	10	3	0	5
CK40HT-51/61C	22	14	10	7	0	9
CK40HT-60D	19	14	11	0	1	2
CK40DT-48C	54	13	10	6	0	8
CK40DT-50/60C	48	12	9	15	0	1
CK40DT-60D	45	11	10	1	0	3

The values in this table are most popular match-up pressures; indoor match-up, indoor air quantity, and indoor load will cause the pressures to vary.

\*\*Amount of charge required in addition to charge shown on unit nameplate.



## Decommissioning

Before carrying out this procedure, it is essential that the technician is completely familiar with the equipment and all its detail. It is recommended good practice that all refrigerants are recovered safely. Prior to the task being carried out, an oil and refrigerant sample shall be taken in case analysis is required prior to re-use the recovered refrigerant. It is essential that electrical power is available before the task is commenced.

- A - Become familiar with the equipment and its operation.
- B - Isolate system electrically.
- C - Before attempting the procedure, ensure that:
  - mechanical handling equipment is available, if required, for handling refrigerant cylinders;
  - all personal protective equipment is available and being used correctly,
  - the recovery process is supervised at all times by a competent person;
  - recovery equipment and cylinders conform to the appropriate standards.

- D - Pump down refrigerant system, if possible.
- E - If a vacuum is not possible, make a manifold so that refrigerant can be removed from various parts of the system.
- F - Make sure that cylinder is situated on the scales before recovery takes place.
- G - Start the recovery machine and operate in accordance with instructions.
- H - Do not overfill cylinders (no more than 80 % volume liquid charge).
- I - Do not exceed the maximum working pressure of the cylinder, even temporarily.
- J - When the cylinders have been filled correctly and the process completed, make sure that the cylinders and the equipment are removed from site promptly and all isolation valves on the equipment are closed off.

Recovered refrigerant shall not be charged into another REFRIGERATING SYSTEM unless it has been cleaned and checked.