

**ML14XC1 (HFC-410A) SERIES OUTDOOR UNITS (3-PHASE)**



**Table of Contents**

Model Number Identification.....	2
Typical Serial Number Identification .....	2
Specifications .....	3
Electrical Data .....	3
Unit Dimensions – Inches (mm) .....	4
Typical Unit Parts Arrangement .....	5
Operating Gauge Set and Service Valves .....	6
Installation .....	8
Unit Placement .....	8
Removing and Installing Louvered Panels .....	10
New or Replacement Line Set.....	11
Brazing Connections .....	13
Flushing Line Set and Indoor Coil .....	16
Installing Indoor Metering Device .....	17
Leak Testing the System .....	18
Evacuating Line Set and Indoor Coil .....	19
Electrical – Circuit Sizing and Wire Routing .....	20
Maintenance .....	24
Typical Field Wiring .....	26
Servicing Units Delivered Void of Charge .....	26
Unit Start-Up .....	27
System Refrigerant .....	27

**⚠ WARNING**

Improper installation, adjustment, alteration, service or maintenance can cause property damage, personal injury or loss of life. Installation and service must be performed by a licensed professional HVAC installer or equivalent, service agency, or the gas supplier.

**⚠ IMPORTANT**

The Clean Air Act of 1990 bans the intentional venting of refrigerant (CFCs, HCFCs and HFCs) as of July 1, 1992. Approved methods of recovery, recycling or reclaiming must be followed. Fines and/or incarceration may be levied for noncompliance.

**⚠ CAUTION**

As with any mechanical equipment, contact with sharp sheet metal edges can result in personal injury. Take care while handling this equipment and wear gloves and protective clothing.

**⚠ WARNING**



Electric Shock Hazard. Can cause injury or death. Unit must be properly grounded in accordance with national and local codes. Line voltage is present at all components when unit is not in operation on units with single-pole contactors. Disconnect all remote electric power supplies before opening access panel. Unit may have multiple power supplies.

**⚠ IMPORTANT**

This unit must be matched with an indoor coil as specified with AHRI. For AHRI Certified system match-ups and expanded ratings, visit [www.LennoxPros.com](http://www.LennoxPros.com). Coils previously charged with HCFC-22 must be flushed.

**General Information**

This ML14XC1 outdoor air conditioner **with all-aluminum coil** is designed for use with HFC-410A refrigerant only. This unit must be installed with an approved indoor air handler or coil. For AHRI Certified system match-ups and expanded ratings, visit [www.LennoxPros.com](http://www.LennoxPros.com). These instructions are intended as a general guide and do not supersede local codes in any way. Consult authorities having jurisdiction before installation.

This outdoor unit is designed for use in systems that use the following refrigerant metering device:

- Thermal expansion valve (CTXV)

**IMPORTANT:** Special procedures are required for cleaning the aluminum coil in this unit. See page 24 in this manual for information.

## Model Number Identification

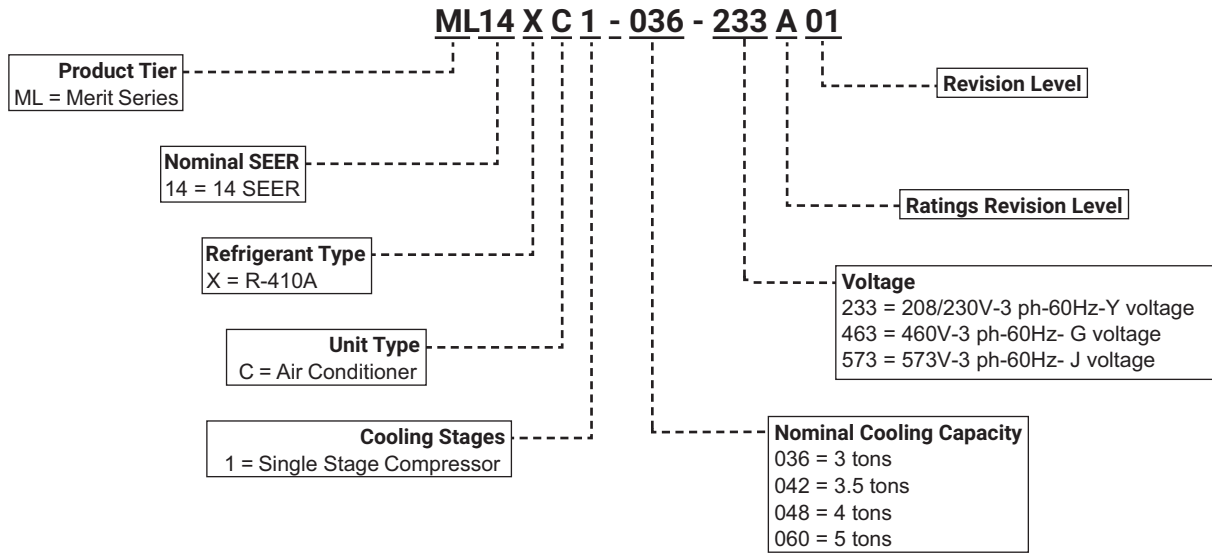

## Typical Serial Number Identification

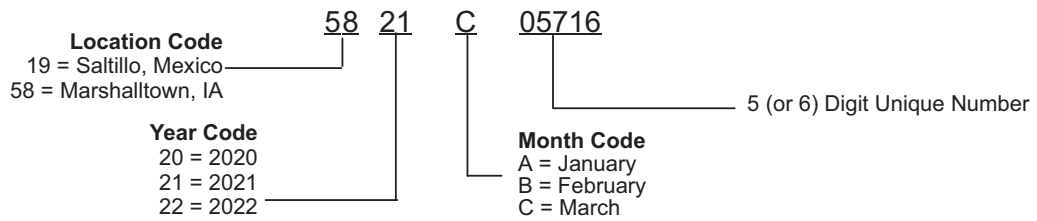

## Specifications

General Data	Model No. - 208/230V-3ph	ML14XC1-036-233	ML14XC1-042-233	ML14XC1-048-233	ML14XC1-060-233
	Model No. - 460V-3ph	ML14XC1-036-463	ML14XC1-042-463	ML14XC1-048-463	ML14XC1-060-463
	Model No. - 575V-3ph	ML14XC1-036-573	- - -	ML14XC1-048-573	ML14XC1-060-573
	Nominal Tonnage	3	3.5	4	5
<b>Indoor Unit Expansion Valve (TXV)</b>		<b>12J19</b>	<b>12J20</b>	<b>12J20</b>	<b>12J20</b>
<sup>1</sup> Sound Rating Number		76	76	78	80
<b>Connections (sweat)</b>	Liquid line o.d. - in.	3/8	3/8	3/8	3/8
	Suction line o.d. - in.	7/8	7/8	7/8	1-1/8
<sup>2</sup> Refrigerant	R-410A charge furnished	7 lbs. 14 oz.	8 lbs. 12 oz.	9 lbs. 8 oz.	12 lbs. 0 oz.
<b>Outdoor Coil</b>	Net face area - Outer coil	18.67	21.00	21.00	29.09
	sq. ft. Inner coil	17.96	20.25	20.25	28.16
	Tube diameter - in.	5/16	5/16	5/16	5/16
	No. of rows	2	2	2	2
	Fins per inch	22	22	22	22
<b>Outdoor Fan</b>	Diameter - in.	22	22	22	26
	No. of Blades	3	3	4	4
	Motor hp	1/6	1/6	1/4	1/4
	Cfm	3160	3050	3600	4550
	Rpm	825	825	825	825
	Watts	190	190	310	310
	<b>Shipping Data - lbs. 1 package</b>		190	211	218

## Electrical Data

Line voltage data - 60 Hz - 3ph		208/230V	460V	575V	208/230V	460V	208/230V	460V	575V	208/230V	460V	575V
		<sup>3</sup> Maximum overcurrent protection (MOCP) amps	15	10	10	20	10	20	10	10	30	15
<sup>4</sup> Minimum circuit ampacity (MCA)	12.2	7.8	5.3	17.9	8.1	18.9	8.5	7.1	21.4	10.7	8.1	
<b>Compressor</b>	Rated Load Amps	9.0	5.8	3.8	13.5	6.0	13.8	6.1	4.9	16.0	7.8	5.7
	Locked Rotor Amps	71	38	37	118	60	123.0	60	33	110	60	39
	Power Factor	0.8	0.8	0.8	0.90	0.90	0.86	0.86	0.86	0.88	0.88	0.88
<b>Outdoor Fan Motor</b>	Full Load Amps	1.0	0.6	0.6	1.0	0.6	1.7	0.9	0.9	1.4	1.0	1
	Locked Rotor Amps	1.9	1.1	1.1	1.9	2.3	3.2	2.3	2.3	3.2	2.5	2.5

## Unit Dimensions – Inches (mm)

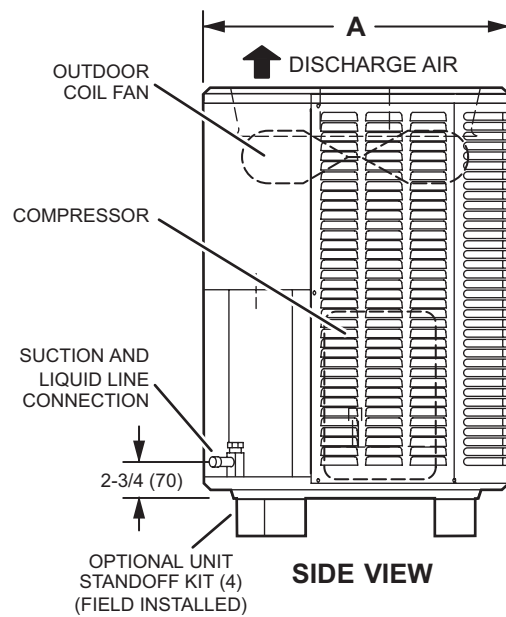
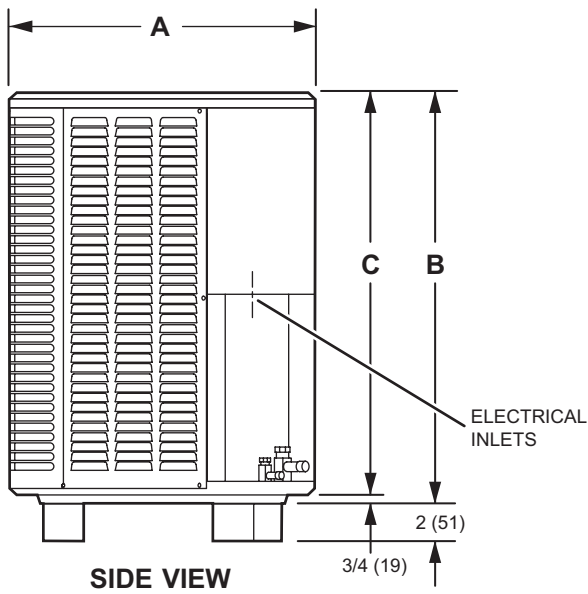
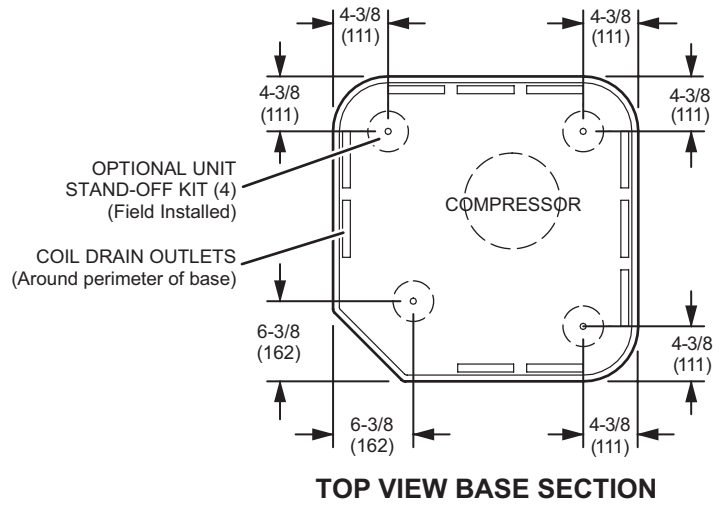
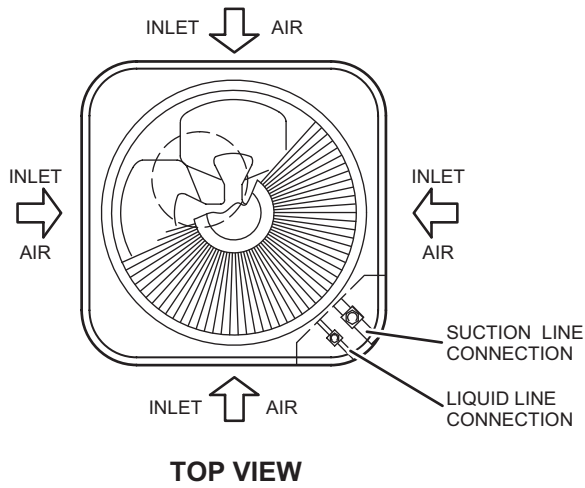

Model No.	A		B		C	
	inches	mm	inches	mm	inches	mm
ML14XC1-036	28-1/4	718	33-1/4	845	32-1/2	826
ML14XC1-042	28-1/4	718	37-1/4	946	36-1/2	927
ML14XC1-048	28-1/4	718	37-1/4	946	36-1/2	927
ML14XC1-060	32-1/4	819	43-1/4	1099	42-1/2	1080

# Typical Unit Parts Arrangement

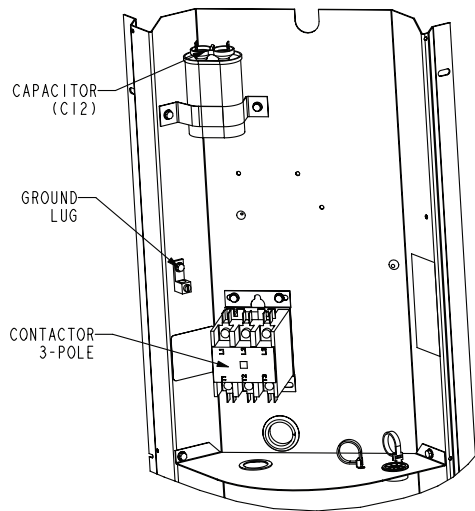

**CONTROL PANEL  
230/460V**

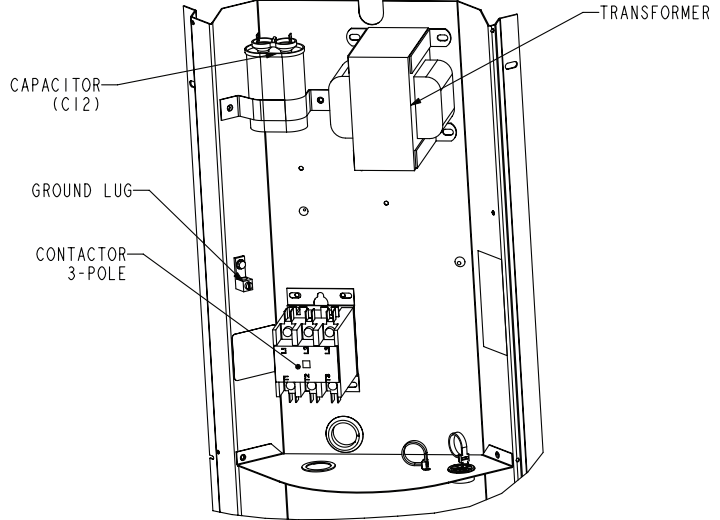

**CONTROL PANEL  
575V**

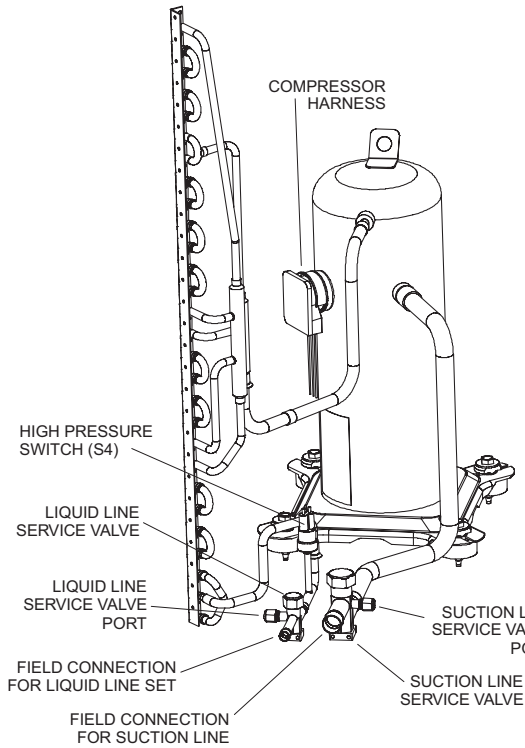

**TYPICAL PLUMBING  
(COPELAND COMPRESSOR)**

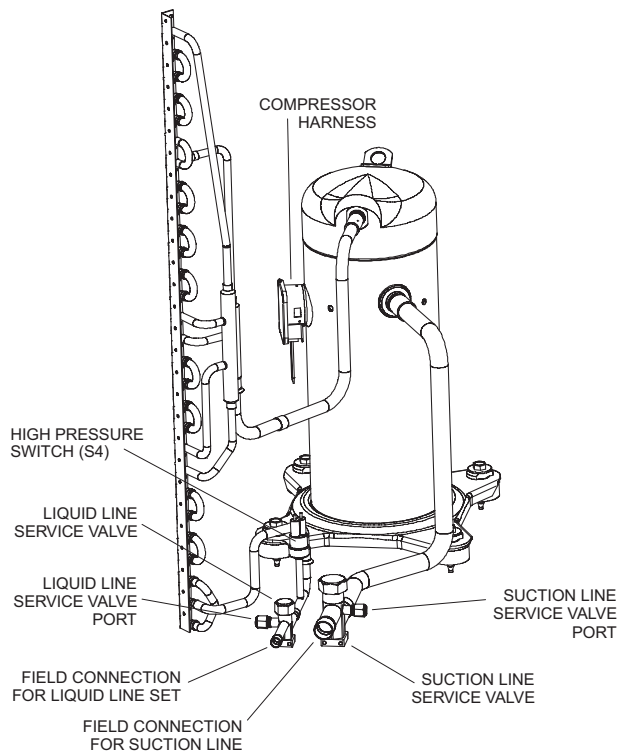

**TYPICAL PLUMBING  
(LG COMPRESSOR)**

**FIGURE 1.**

## Operating Gauge Set and Service Valves

### TORQUE REQUIREMENTS

When servicing or repairing heating, ventilating, and air conditioning components, ensure the fasteners are appropriately tightened. Table 2 lists torque values for fasteners.

### IMPORTANT

Only use Allen wrenches of sufficient hardness (50Rc - Rockwell Harness Scale minimum). Fully insert the wrench into the valve stem recess.

Service valve stems are factory-torqued (from 9 ft-lbs for small valves, to 25 ft-lbs for large valves) to prevent refrigerant loss during shipping and handling. Using an Allen wrench rated at less than 50Rc risks rounding or breaking off the wrench, or stripping the valve stem recess.

See the Lennox Service and Application Notes #C-08-1 for further details and information.

### IMPORTANT

To prevent stripping of the various caps used, the appropriately sized wrench should be used and fitted snugly over the cap before tightening.

TABLE 1. Torque Requirements

Parts	Recommended Torque	
Service valve cap	8 ft.- lb.	11 NM
Sheet metal screws	16 ft.- lb.	2 NM
Machine screws #10	28 ft.- lb.	3 NM
Compressor bolts	90 in.- lb.	10 NM
Gauge port seal cap	8 ft.- lb.	11 NM

### USING MANIFOLD GAUGE SET

When checking the system charge, only use a manifold gauge set that features low loss anti-blow back fittings.

Manifold gauge set used with HFC-410A refrigerant systems must be capable of handling the higher system operating pressures. The gauges should be rated for use with pressures of 0 - 800 psig on the high side and a low side of 30" vacuum to 250 psig with dampened speed to 500 psi. Gauge hoses must be rated for use at up to 800 psig of pressure with a 4000 psig burst rating.

### OPERATING SERVICE VALVES

The liquid and vapor line service valves are used for removing refrigerant, flushing, leak testing, evacuating, checking charge and charging. Each valve is equipped with a service port which has a factory-installed valve stem. Figure 2 provides information on access and operation of both angle and ball service valves

# SERVICE VALVES ANGLE AND BALL

## Operating Angle Type Service Valve:

1. Remove stem cap with an appropriately sized wrench.
2. Use a service wrench with a hex-head extension (3/16" for liquid line valve sizes and 5/16" for vapor line valve sizes) to back the stem out counterclockwise as far as it will go.

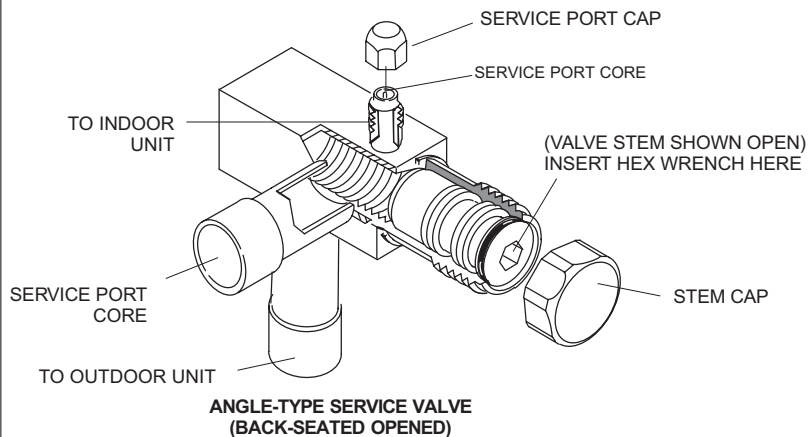

When service valve is **OPEN**, the service port is open to line set, indoor and outdoor unit.

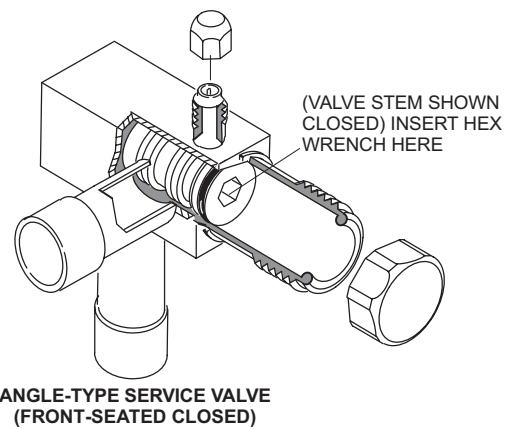

WHEN SERVICE VALVE IS **CLOSED**, THE SERVICE PORT IS OPEN TO THE LINE SET AND INDOOR UNIT.

## Operating Ball Type Service Valve:

1. Remove stem cap with an appropriately sized wrench.
2. Use an appropriately sized wrench to open. To open valve, rotate stem counterclockwise 90°. To close rotate stem clockwise 90°.

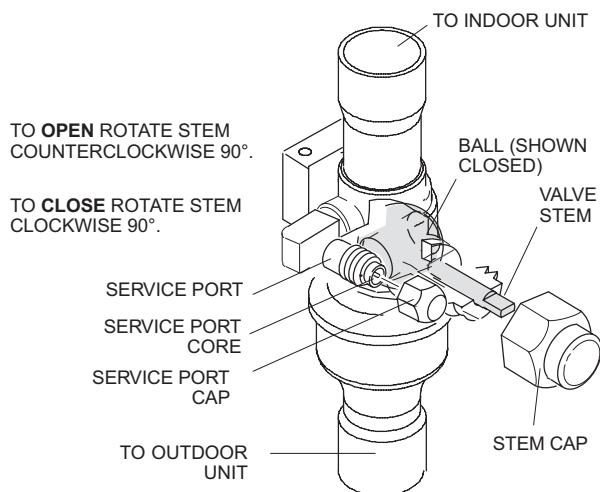

## To Access Service Port:

A service port cap protects the service port core from contamination and serves as the primary leak seal.

1. Remove service port cap with an appropriately sized wrench.
2. Connect gauge set to service port.
3. When testing is completed, replace service port cap and tighten as follows:
  - With torque wrench: Finger tighten and torque cap per table 3.
  - Without torque wrench: Finger tighten and use an appropriately sized wrench to turn an additional 1/6 turn clockwise.

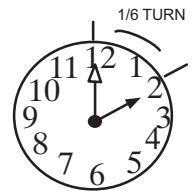

## Reinstall Stem Cap:

Stem cap protects the valve stem from damage and serves as the primary seal. Replace the stem cap and tighten as follows:

- With Torque Wrench: Finger tighten and then torque cap per table 3.
- Without Torque Wrench: Finger tighten and use an appropriately sized wrench to turn an additional 1/12 turn clockwise.

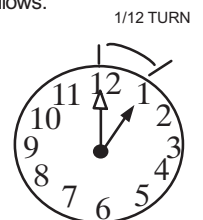

NOTE — A label with specific torque requirements may be affixed to the stem cap. If the label is present, use the specified torque.

**FIGURE 2. Angle and Ball Service Valves**

## Installation

### Unit Placement

See Unit Dimensions on page 4 for sizing mounting slab, platforms or supports.

### **⚠ CAUTION**

In order to avoid injury, take proper precaution when lifting heavy objects..

### POSITIONING CONSIDERATIONS

Consider the following when positioning the unit:

- Some localities are adopting sound ordinances based on the unit's sound level registered from the adjacent property, not from the installation property. Install the unit as far as possible from the property line.
- When possible, do not install the unit directly outside a window. Glass has a very high level of sound transmission. For proper placement of unit in relation to a window see the provided illustration in figure 6, detail A.

### PLACING UNIT ON SLAB

When installing unit at grade level, the top of the slab should be high enough above grade so that water from higher ground will not collect around the unit.

The slab should have a slope tolerance as described in figure 6, detail B.

**NOTE** – If necessary for stability, anchor unit to slab as described in figure 4, detail B.

### ROOF MOUNTING

Install the unit a minimum of 6 inches (152 mm) above the roof surface to avoid ice build-up around the unit. Locate the unit above a load bearing wall or area of the roof that can adequately support the unit. Consult local codes for rooftop applications. If unit coil cannot be mounted away from prevailing winter winds, a wind barrier should be constructed. Size barrier at least the same height and width as outdoor unit. Mount barrier 24 inches (610 mm) from the sides of the unit in the direction of prevailing winds.

### **⚠ NOTICE**

#### Roof Damage!

This system contains both refrigerant and oil. Some rubber roofing material may absorb oil, causing the rubber to swell. Bubbles in the rubber roofing material can cause leaks. Protect the roof surface to avoid exposure to refrigerant and oil during service and installation. Failure to follow this notice could result in damage to roof surface.

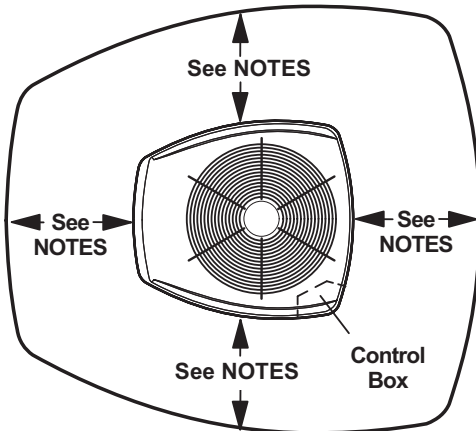

#### NOTES:

Service clearance of 30 in. must be maintained on one of the sides adjacent to the control box.

Clearance to one of the other three sides must be 36 in.

Clearance to one of the remaining two sides may be 12 in. and the final side may be 6 in.

A clearance of 24 in. must be maintained between two units.

48 in. clearance required on top of unit.

**NOTICE:** Specific applications may require adjustment of the listed installation clearances to provide protection for the unit from physical damage or to avoid conditions which limit operating efficiency. (Example: Clearances may have to be increased to prevent snow or ice from falling on the top of the unit. Additional clearances may also be required to prevent air recirculation when the unit is installed under a deck or in another tight space.)

**FIGURE 3. Installation Clearances**



## DETAIL A

INSTALL UNIT AWAY FROM WINDOWS

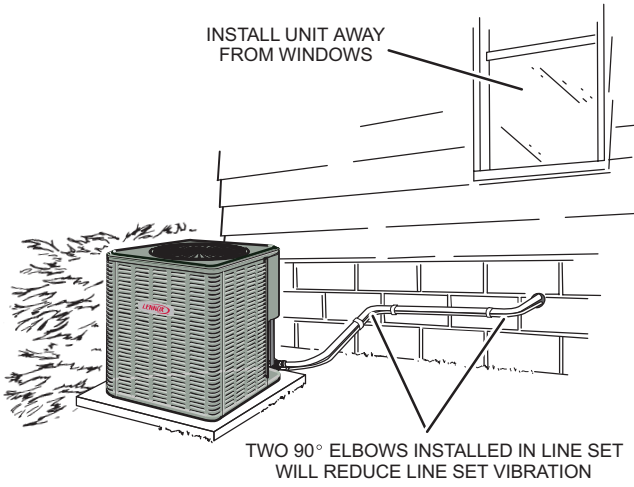

## DETAIL B

Install unit level or, if on a slope, maintain slope tolerance of 2 degrees (or 2 inches per 5 feet [50 mm per 1.5 m]) away from building structure.

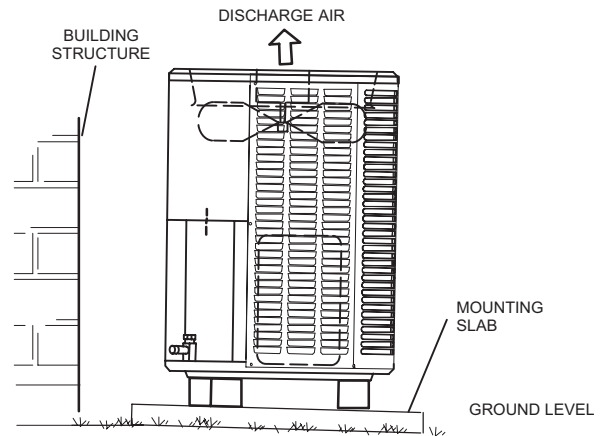

**FIGURE 4. Placement and Slab Mounting**

## Removing and Installing Louvered Panels



### WARNING

To prevent personal injury, or damage to panels, unit or structure, be sure to observe the following:

While installing or servicing this unit, carefully stow all removed panels out of the way, so that the panels will not cause injury to personnel, nor cause damage to objects or structures nearby, nor will the panels be subjected to damage (e.g., being bent or scratched).

While handling or stowing the panels, consider any weather conditions, especially windy conditions, that may cause panels to be blown around and battered.

When removing the unit panels. Remove panel **A** first, then **B**, **C** and finally **D**. When reinstalling panels, reverse that order starting with panel **D**, **C**, **B** and finally **A**.

### REMOVAL

#### STEP 1

To remove panel, remove mounting screws securing panel to the unit.

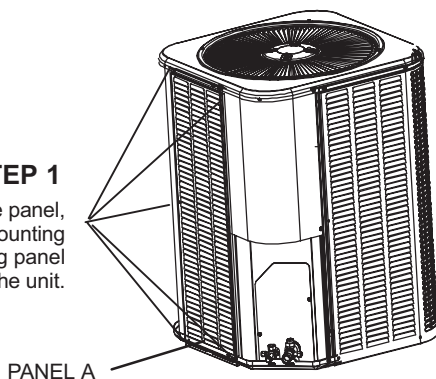

#### STEP 2

Slightly lift panel **A** in order to clear side lips of panel from base of unit.

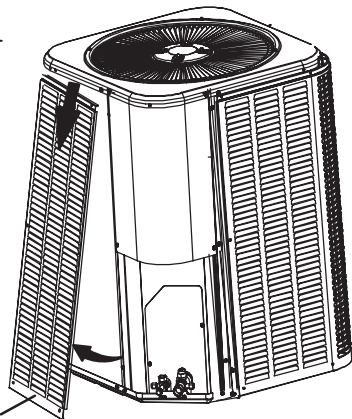

#### STEP 3

Tilt panel out slightly and pull downward to remove.

Repeat steps 1, 2 and 3 to remove panels **B**, **C** and **D**.

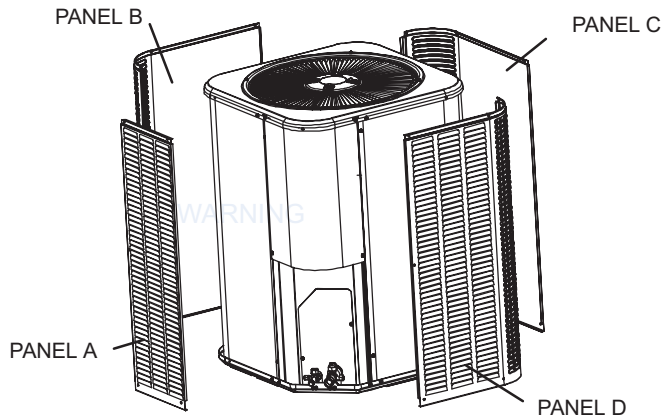

### INSTALLATION

#### STEP 1

Starting with panel **D**. Insert panel unit top cap lip and lift slightly to clear side lip of panel from base.

TOP CAP

#### STEP 2

Move panel in towards unit. Align left / right side lips of panel with groove inserts along left / right side of unit.

SIDE GROOVE

#### STEP 3

Secure panel with mounting screws.

Repeat steps 1 and 2 when installing panels **C**, **B** and **A**.

BASE

PANEL D

FIGURE 5. Removing and Installing Panels

## New or Replacement Line Set

This section provides information on new installation or replacement of existing line set. If a new or replacement line set is not required, then proceed to Brazing Connections on page 13.

Field refrigerant piping consists of liquid and suction lines from the outdoor unit (brazed connections) to the indoor unit coil (flare or braze connections). Use Lennox L15 (braze, non-flare) series line set, or use field-fabricated refrigerant lines as listed in table 2.

TABLE 2

REFRIGERANT LINE SET – INCHES (MM)					
Model	Valve Field Connections		Recommended Line Set		
	Liquid Line	Suction Line	Liquid Line	Suction Line	L15 Line Sets
-036					
-042	3/8 in. (10 mm)	7/8 in. (22 mm)	3/8 in. (10 mm)	7/8 in. (22 mm)	L15-65 15 ft. - 50 ft. (4.6 m - 15 m)
-048					
-060	3/8 in. (10 mm)	1-1/8 in. (28 mm)	3/8 in. (10 mm)	1-1/8 in. (28 mm)	Field Fabricated

NOTE - Some applications may require a field-provided 7/8" to 1-1/8" adapter.

**NOTE** - When installing refrigerant lines longer than 50 feet, refer to the Refrigerant Piping Design and Fabrication Guidelines manual available on [LennoxPros.com](http://LennoxPros.com) (Corp. 9351-L9), or contact the Technical Support Department Product Application group for assistance.

**NOTE** - For new or replacement line set installation, refer to Service and Application Note - Corp. 9112-L4 (C-91-4).

## ⚠ WARNING



When using a high pressure gas such as nitrogen to pressurize a refrigeration or air conditioning system, use a regulator that can control the pressure down to 1 or 2 psig (6.9 to 13.8 kPa).

## ⚠ WARNING

Refrigerant can be harmful if it is inhaled. Refrigerant must be used and recovered responsibly. Failure to follow this warning may result in personal injury or death.

## ⚠ WARNING



Fire, Explosion and Personal Safety hazard. Failure to follow this warning could result in damage, personal injury or death.

Never use oxygen to pressurize or purge refrigeration lines. Oxygen, when exposed to a spark or open flame, can cause fire and/or an explosion, that could result in property damage, personal injury or death.

If refrigerant lines are routed through a wall, seal and isolate the opening so vibration is not transmitted to the building. Pay close attention to line set isolation during installation of any HVAC system. When properly isolated from building structures (walls, ceilings, floors), the refrigerant lines will not create unnecessary vibration and subsequent sounds.

The compressor is charged with sufficient Polyol ester oil for line set lengths up to 50 feet. Recommend adding oil to system based on the amount of refrigerant charge in the system. No need to add oil in a system with 20 pounds of refrigerant or less. For systems over 20 pounds - add one ounce for every five pounds of refrigerant over 20 pounds. Recommended topping-off POE oils are Mobil EAL ARC-TIC 22 CC or ICI EMKARATE RL32CF.

### LIQUID LINE FILTER DRIER INSTALLATION

The filter drier (one is shipped with each ML14XC1 unit) must be field installed in the liquid line between the outdoor unit's liquid line service valve and the indoor coil's metering device as illustrated in figure 6. This filter drier must be installed to ensure a clean, moisture-free system. Failure to install the filter drier will void the warranty. A replacement filter drier is available from Lennox. See Brazing Connections on page for special procedures on brazing filter drier connections to the liquid line.

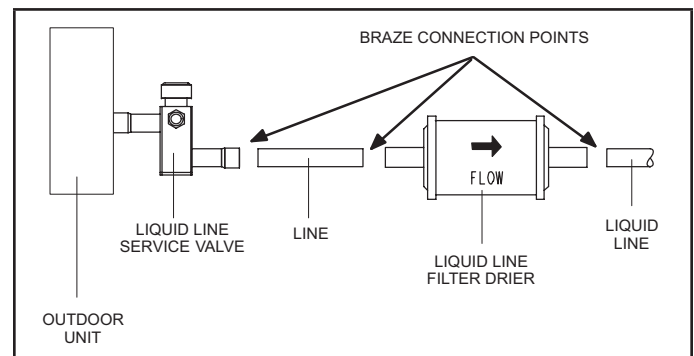

FIGURE 6. Typical Liquid Line Filter Drier Installation

# LINE SET

**IMPORTANT** — Refrigerant lines must not contact structure.

## INSTALLATION

**Line Set Isolation** — The following illustrations are examples of proper refrigerant line set isolation:

### REFRIGERANT LINE SET — TRANSITION FROM VERTICAL TO HORIZONTAL

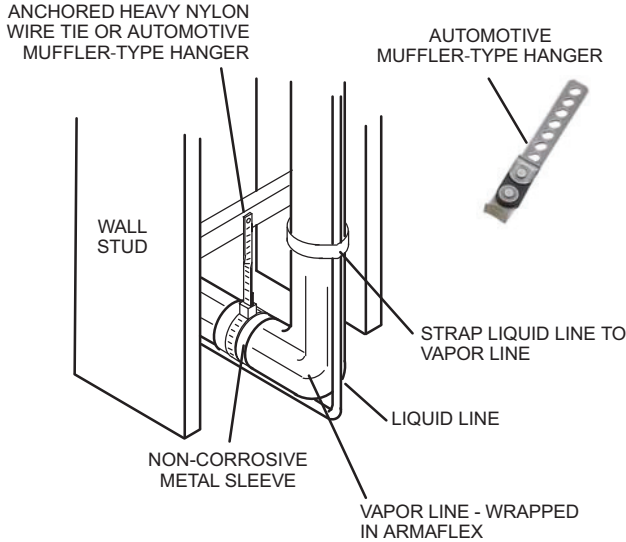

### REFRIGERANT LINE SET — INSTALLING HORIZONTAL RUNS

To hang line set from joist or rafter, use either metal strapping material or anchored heavy nylon wire ties.

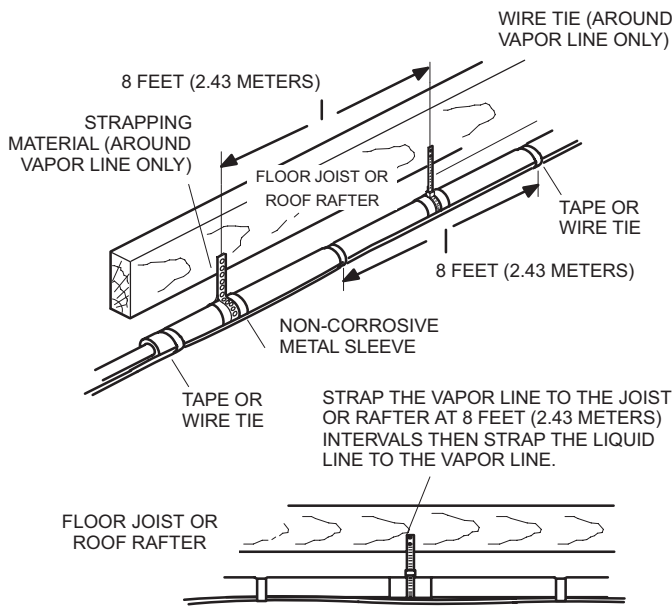

### REFRIGERANT LINE SET — INSTALLING VERTICAL RUNS (NEW CONSTRUCTION SHOWN)

**NOTE** — Insulate liquid line when it is routed through areas where the surrounding ambient temperature could become higher than the temperature of the liquid line or when pressure drop is equal to or greater than 20 psig.

**IMPORTANT** — Refrigerant lines must not contact wall

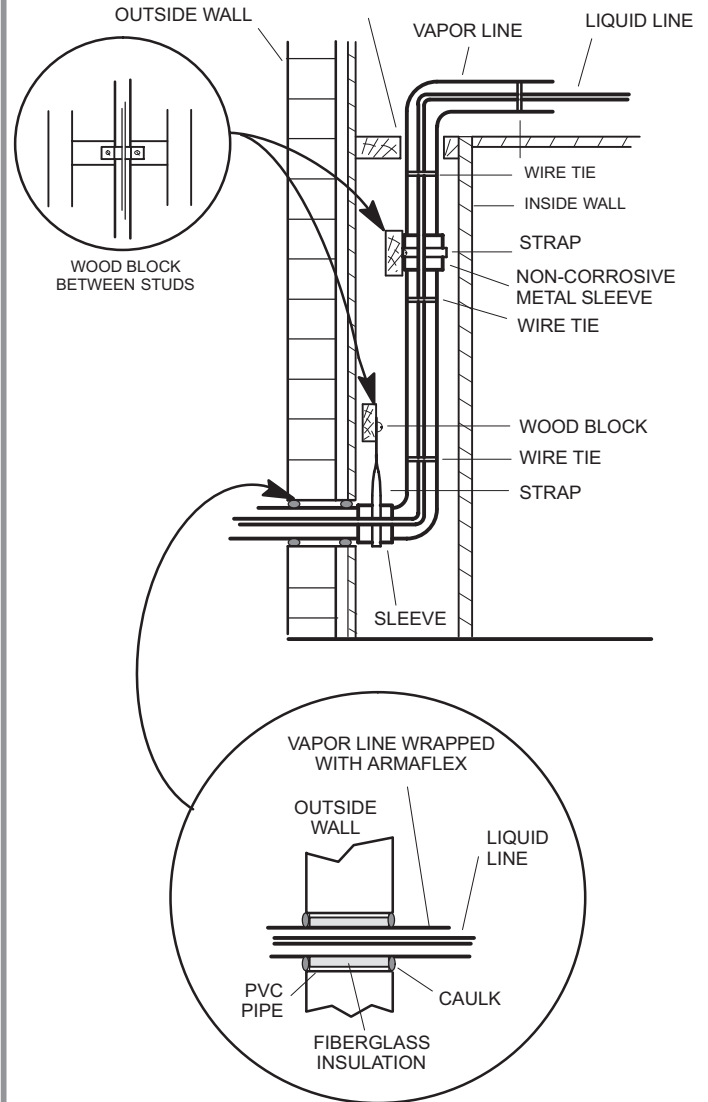

**NOTE** — Similar installation practices should be used if line set is to be installed on exterior of outside wall.

**WARNING** — Polyol ester (POE) oils used with HFC-410A refrigerant absorb moisture very quickly. It is very important that the refrigerant system be kept closed as much as possible. **DO NOT** remove line set caps or service valve stub caps until you are ready to make connections.

FIGURE 7. Line Set Installation

## Brazing Connections

Use the procedures outlined in figures 8 and 9 for brazing line set connections to service valves.

### WARNING



Danger of fire. Bleeding the refrigerant charge from only the high side may result in pressurization of the low side shell and suction tubing. Application of a brazing torch to a pressurized system may result in ignition of the refrigerant and oil mixture. Check the high and low pressures before applying heat.

### CAUTION

Brazing alloys and flux contain materials which are hazardous to your health.

Avoid breathing vapors or fumes from brazing operations. Perform operations only in well-ventilated areas.

Wear gloves and protective goggles or face shield to protect against burns.

Wash hands with soap and water after handling brazing alloys and flux.

### IMPORTANT

Allow braze joint to cool before removing the wet rag from the service valve. Temperatures above 250°F can damage valve seals.

### IMPORTANT

Use silver alloy brazing rods with 5% minimum silver alloy for copper-to-copper brazing. Use 45% minimum alloy for copper-to-brass and copper-to-steel brazing.

### IMPORTANT

If this unit is being matched with an approved line set or indoor unit coil that was previously charged with mineral oil, or if it is being matched with a coil which was manufactured before January of 1999, the coil and line set must be flushed prior to installation. Take care to empty all existing traps. Polyol ester (POE) oils are used in Lennox units charged with HFC-410A refrigerant. Residual mineral oil can act as an insulator, preventing proper heat transfer. It can also clog the expansion device and reduce system performance and capacity.

Failure to properly flush the system, per this instruction and the detailed Installation and Service Procedures manual will void the warranty.

# 1 PIPING PANEL REMOVAL AND LINE SET PREPARATION

Remove piping panel for easier access to service valves. Cut ends of the refrigerant lines square (free from nicks or dents) and debur the ends. The pipe must remain round. Do not crimp end of the line.

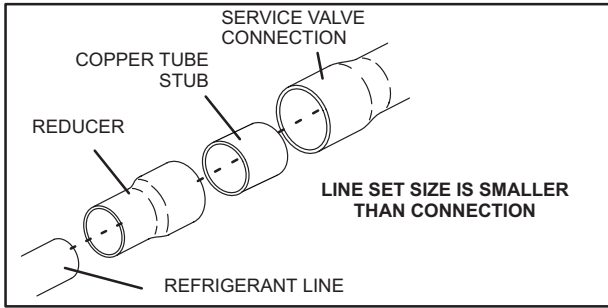
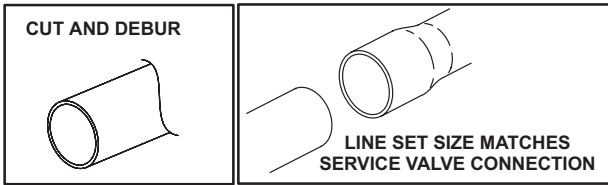

DO NOT CRIMP SERVICE VALVE CONNECTOR WHEN PIPE IS SMALLER THAN CONNECTION

# 2 CAP AND CORE REMOVAL

Remove service cap and core from both the suction and liquid line service ports.

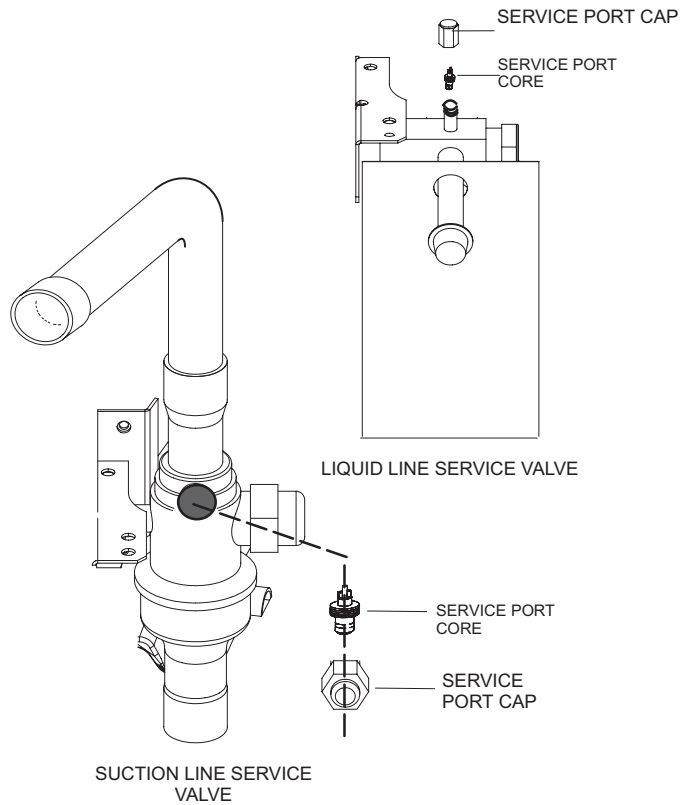

# 3 ATTACH THE MANIFOLD GAUGE SET FOR BRAZING LIQUID AND SUCTION LINE SERVICE VALVES

- A. Connect gauge set low pressure side to liquid line service valve (service port).
- B. Connect gauge set center port to bottle of nitrogen with regulator.
- C. With valve core removed from the suction line service port, nitrogen flow will have an exit point.

SUCTION SERVICE PORT MUST BE OPEN AND SERVICE PORT CORE REMOVED TO ALLOW EXIT POINT FOR NITROGEN FLOW

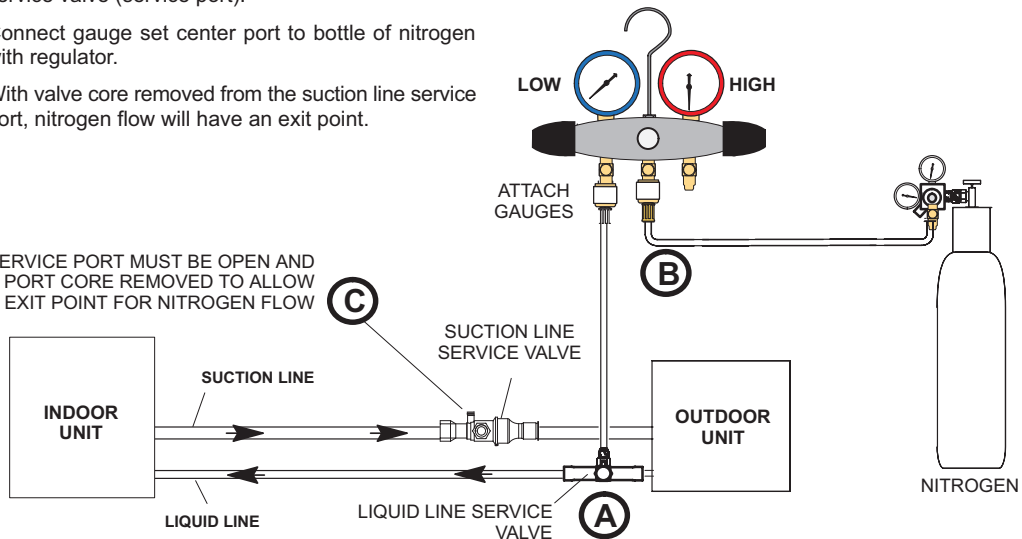

FIGURE 8. Brazing Procedures

## 4 WRAP SERVICE VALVES

To help protect service valve seals during brazing, wrap water-saturated cloths around service valve bodies and copper tube stubs. Use additional water-saturated cloths underneath the valve body to protect the base paint.

## 5 FLOW NITROGEN

Flow regulated nitrogen (at 1 to 2 psig) through the refrigeration gauge set into the valve stem port connection on the liquid service valve and out of the suction / vapor valve stem port. See steps 3A, 3B and 3C on manifold gauge set connections.

## 6 BRAZE LINE SET

Wrap both service valves with water-saturated cloths as illustrated here and as mentioned in step 4, before brazing to line set. Cloths must remain water-saturated throughout the brazing and cool-down process.

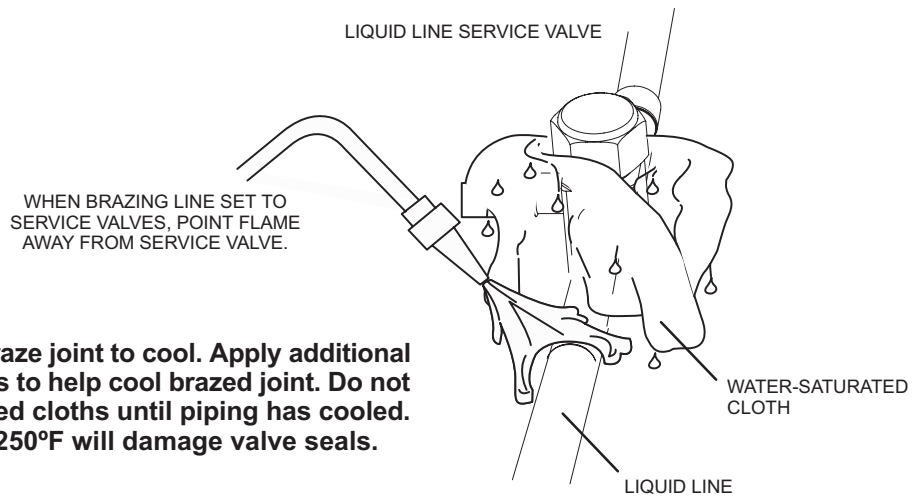

**IMPORTANT - Allow braze joint to cool. Apply additional water-saturated cloths to help cool brazed joint. Do not remove water-saturated cloths until piping has cooled. Temperatures above 250°F will damage valve seals.**

### WARNING

**FIRE, PERSONAL INJURY, OR PROPERTY DAMAGE** may result if you do not wrap a water-saturated cloth around both liquid and suction line service valve bodies and copper tube stub while brazing the line set! The braze, when complete, must be quenched with water to absorb any residual heat.

Do not open service valves until refrigerant lines and indoor coil have been leak-tested and evacuated. Refer to Installation and Service Procedures manual found on [LennoxPros.com](http://LennoxPros.com).

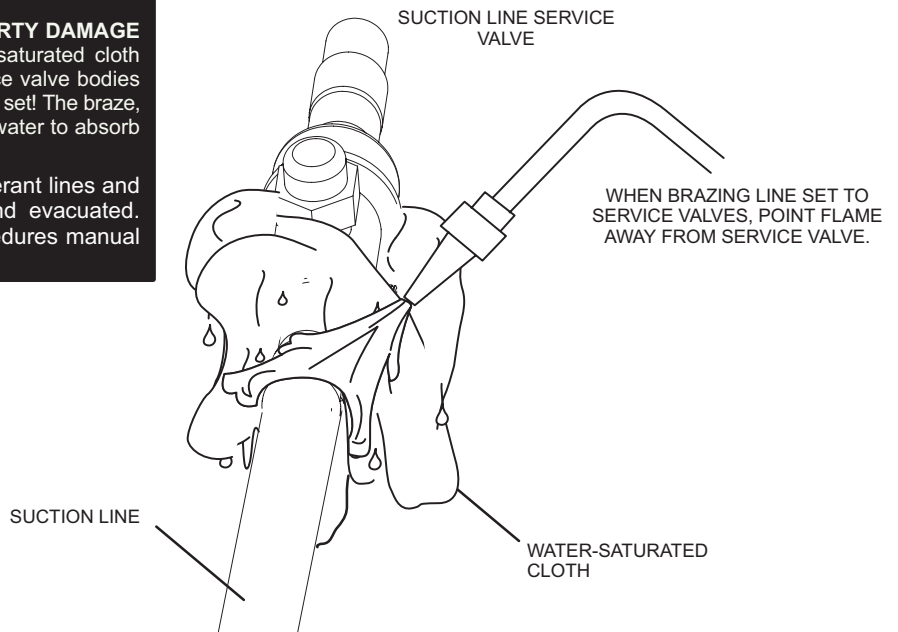

## 7 PREPARATION FOR NEXT STEP

Disconnect manifold gauge set from service ports after all connections have been brazed. Apply additional water-saturated cloths to both service valves to cool piping. Once piping is cool, remove all water-saturated cloths.

**FIGURE 9. Brazing Procedures (Cont'd)**

## Flushing Line Set and Indoor Coil

### 1A TYPICAL EXISTING FIXED ORIFICE REMOVAL PROCEDURE (UNCASED OR COIL SHOWN)

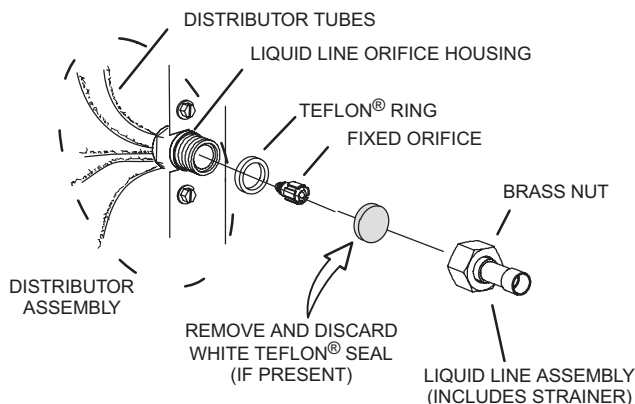

- A On fully cased coils, remove the coil access and plumbing panels.
- B Remove any shipping clamps holding the liquid line and distributor assembly.
- C Using two wrenches, disconnect liquid line from liquid line orifice housing. Take care not to twist or damage distributor tubes during this process.
- D Remove and discard fixed orifice, valve stem assembly if present and Teflon® washer as illustrated above.
- E Use a field-provided fitting to temporarily reconnect the liquid line to the indoor unit's liquid line orifice housing.

### 1B TYPICAL EXISTING EXPANSION VALVE REMOVAL PROCEDURE (UNCASED COIL SHOWN)

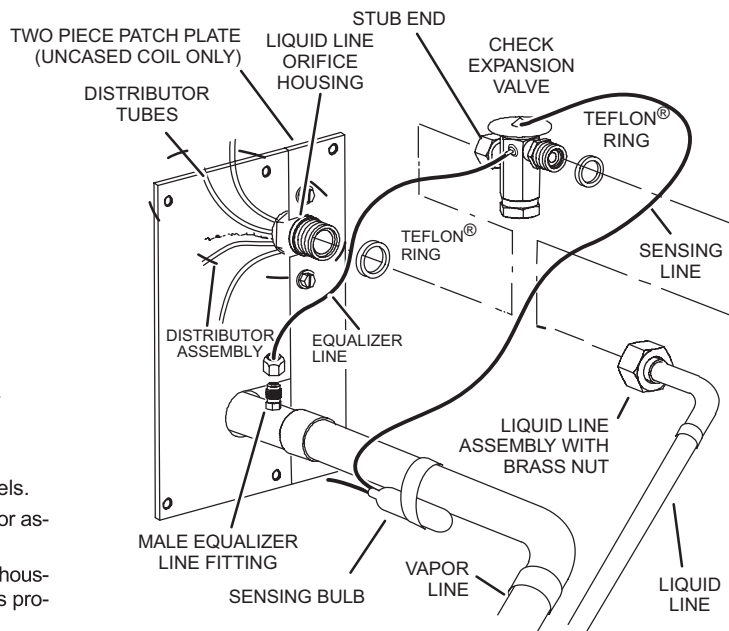

- A On fully cased coils, remove the coil access and plumbing panels.
- B Remove any shipping clamps holding the liquid line and distributor assembly.
- C Disconnect the equalizer line from the check expansion valve equalizer line fitting on the vapor line.
- D Remove the vapor line sensing bulb.
- E Disconnect the liquid line from the check expansion valve at the liquid line assembly.
- F Disconnect the check expansion valve from the liquid line orifice housing. Take care not to twist or damage distributor tubes during this process.
- G Remove and discard check expansion valve and the two Teflon® rings.
- H Use a field-provided fitting to temporary reconnect the liquid line to the indoor unit's liquid line orifice housing.

### 2 CONNECT GAUGES AND EQUIPMENT FOR FLUSHING PROCEDURE

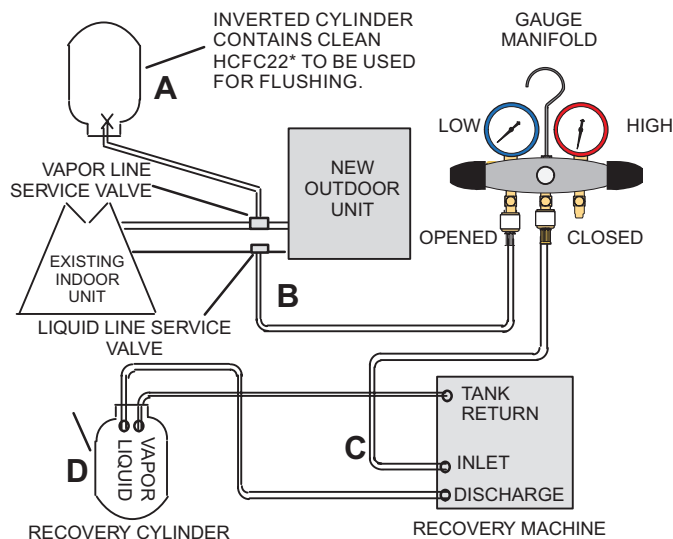

- A Inverted HCFC-22 cylinder with clean refrigerant\* to the vapor service valve.
- B HCFC-22 gauge set (low side) to the liquid line valve.
- C HCFC-22 gauge set center port to inlet on the recovery machine with an empty recovery tank to the gauge set.
- D Connect recovery tank to recovery machines per machine instructions.

**\*IMPORTANT - Clean refrigerant is any refrigerant in a system that has not had compressor burn out. If the system has experienced burn out, it is recommended that the existing line set and indoor coil be replaced.**

### 3 FLUSHING LINE SET

The line set and indoor unit coil must be flushed with at least the same amount of clean refrigerant\* that previously charged the system. Check the charge in the flushing cylinder before proceeding.

- A Set the recovery machine for liquid recovery and start the recovery machine. Open the gauge set valves to allow the recovery machine to pull a vacuum on the existing system line set and indoor unit coil.
- B Invert the cylinder of clean HCFC-22\* and open its valve to allow liquid refrigerant to flow into the system through the vapor line valve. Allow the refrigerant to pass from the cylinder and through the line set and the indoor unit coil before it enters the recovery machine.
- C After all of the liquid refrigerant has been recovered, switch the recovery machine to vapor recovery so that all of the HCFC-22 vapor is recovered. Allow the recovery machine to pull the system down to 0.
- D Close the valve on the inverted HCFC-22 drum and the gauge set valves. Pump the remaining refrigerant out of the recovery machine and turn the machine off.

FIGURE 10. Removing Metering Device and Flushing



## Installing Indoor Metering Device

This outdoor unit is designed for use in systems that use an expansion valve (TXV) metering device at the indoor coil. The expansion valve can be installed internal or external to the indoor coil. In applications where an uncased coil is being installed in a field-provided plenum, install the

expansion valve in a manner that will provide access for field servicing of the expansion valve. Refer to below illustration for reference during installation of expansion valve unit.

### INDOOR EXPANSION VALVE INSTALLATION

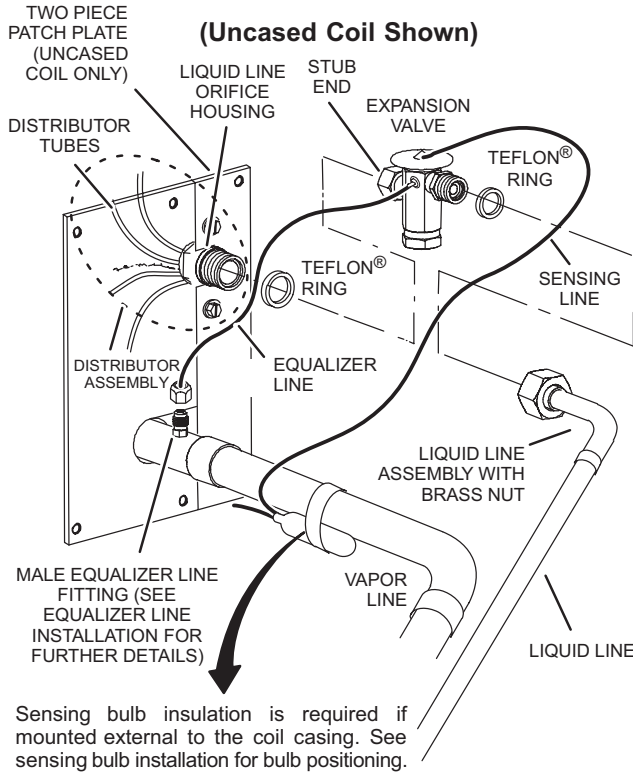

- Remove the field-provided fitting that temporary reconnected the liquid line to the indoor unit's distributor assembly.
- Install one of the provided Teflon® rings around the stubbed end of the expansion valve and lightly lubricate the connector threads and expose surface of the Teflon® ring with refrigerant oil.
- Attach the stubbed end of the expansion valve to the liquid line orifice housing. Finger tighten and use an appropriately sized wrench to turn an additional 1/2 turn clockwise as illustrated in the figure above, or 20 ft-lb.
- Place the remaining Teflon® washer around the other end of the expansion valve. Lightly lubricate connector threads and expose surface of the Teflon® ring with refrigerant oil.
- Attach the liquid line assembly to the expansion valve. Finger tighten and use an appropriately sized wrench to turn an additional 1/2 turn clockwise as illustrated in the figure above or 20 ft-lb.

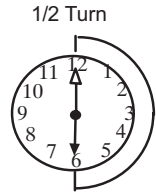

### SENSING BULB INSTALLATION

- Attach the vapor line sensing bulb in the proper orientation as illustrated to the right using the clamp and screws provided.
- NOTE** — Confirm proper thermal contact between vapor line and expansion bulb before insulating the sensing bulb once installed.
- Connect the equalizer line from the expansion valve to the equalizer vapor port on the vapor line. Finger tighten the flare nut plus 1/8 turn (7 ft-lbs) as illustrated below.

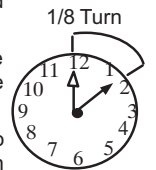

### EQUALIZER LINE INSTALLATION

- Remove and discard either the flare seal cap or flare nut with copper flare seal bonnet from the equalizer line port on the vapor line as illustrated in the figure to the right.
- Remove and discard either the flare seal cap or flare nut with copper flare seal bonnet from the equalizer line port on the vapor line as illustrated in the figure to the right.

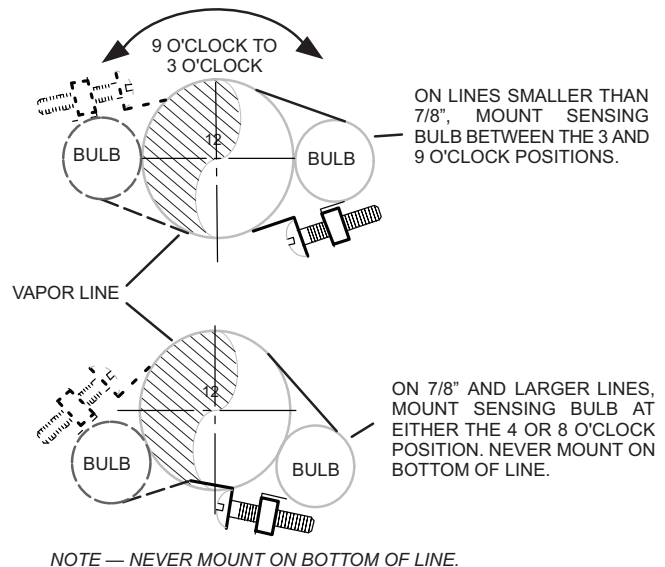
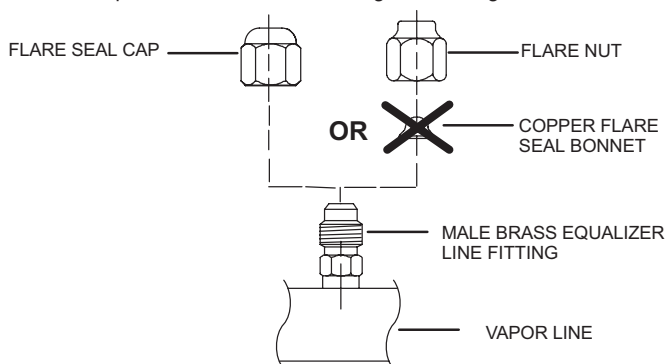

FIGURE 11

## Leak Testing the System

### **! IMPORTANT**

Leak detector must be capable of sensing HFC refrigerant.

### **! IMPORTANT**

The Environmental Protection Agency (EPA) prohibits the intentional venting of HFC refrigerants during maintenance, service, repair and disposal of appliance. Approved methods of recovery, recycling or reclaiming must be followed.

# LEAK TEST

## LINE SET AND INDOOR COIL

**NOTE - NORMALLY, THE HIGH PRESSURE HOSE IS CONNECTED TO THE LIQUID LINE PORT. HOWEVER, CONNECTING IT TO THE VAPOR PORT BETTER PROTECTS THE MANIFOLD GAUGE SET FROM HIGH PRESSURE DAMAGE.**

### **1 CONNECT GAUGE SET**

- A. CONNECT AN HFC-410A MANIFOLD GAUGE SET HIGH PRESSURE HOSE TO THE VAPOR VALVE SERVICE PORT.
- B. WITH BOTH MANIFOLD VALVES CLOSED, CONNECT THE CYLINDER OF HFC-410A REFRIGERANT TO THE CENTER PORT OF THE MANIFOLD GAUGE SET.

*NOTE - LATER IN THE PROCEDURE, THE HFC-410A CONTAINER WILL BE REPLACED BY THE NITROGEN CONTAINER.*

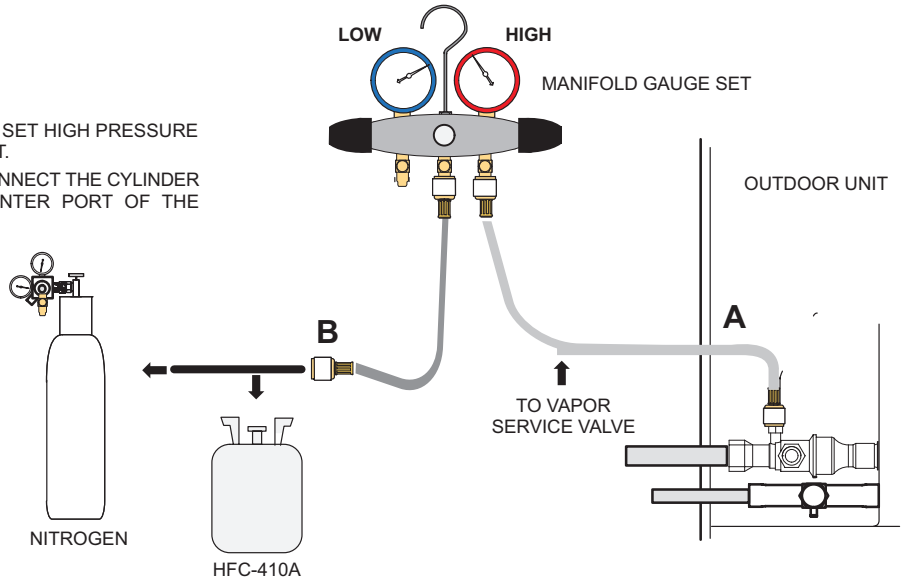

### **2 TEST FOR LEAKS**

AFTER THE LINE SET HAS BEEN CONNECTED TO THE INDOOR AND OUTDOOR UNITS, CHECK THE LINE SET CONNECTIONS AND INDOOR UNIT FOR LEAKS. USE THE FOLLOWING PROCEDURE TO TEST FOR LEAKS:

- A. WITH BOTH MANIFOLD VALVES CLOSED, CONNECT THE CYLINDER OF HFC-410A REFRIGERANT TO THE CENTER PORT OF THE MANIFOLD GAUGE SET. OPEN THE VALVE ON THE HFC-410A CYLINDER (VAPOR ONLY).
- B. OPEN THE HIGH PRESSURE SIDE OF THE MANIFOLD TO ALLOW HFC-410A INTO THE LINE SET AND INDOOR UNIT. WEIGH IN A TRACE AMOUNT OF HFC-410A [A TRACE AMOUNT IS A MAXIMUM OF TWO OUNCES (57 G) REFRIGERANT OR THREE POUNDS (31 KPA) PRESSURE]. CLOSE THE VALVE ON THE HFC-410A CYLINDER AND THE VALVE ON THE HIGH PRESSURE SIDE OF THE MANIFOLD GAUGE SET. DISCONNECT THE HFC-410A CYLINDER.
- C. CONNECT A CYLINDER OF DRY NITROGEN WITH A PRESSURE REGULATING VALVE TO THE CENTER PORT OF THE MANIFOLD GAUGE SET.
- D. ADJUST DRY NITROGEN PRESSURE TO 150 PSIG (1034 KPA). OPEN THE VALVE ON THE HIGH SIDE OF THE MANIFOLD GAUGE SET IN ORDER TO PRESSURIZE THE LINE SET AND THE INDOOR UNIT.
- E. AFTER A FEW MINUTES, OPEN ONE OF THE SERVICE VALVE PORTS AND VERIFY THAT THE REFRIGERANT ADDED TO THE SYSTEM EARLIER IS MEASURABLE WITH A LEAK DETECTOR.
- F. AFTER LEAK TESTING, DISCONNECT GAUGES FROM SERVICE PORTS.

**FIGURE 12. System Leak Test**

## Evacuating Line Set and Indoor Coil

### 1 CONNECT GAUGE SET

**NOTE** — Remove cores from service valves (if not already done).

- A** Connect low side of manifold gauge set with 1/4 SAE in-line tee to vapor line service valve
- B** Connect high side of manifold gauge set to liquid line service valve
- C** Connect micron gauge available connector on the 1/4 SAE in-line tee.
- D** Connect the vacuum pump (with vacuum gauge) to the center port of the manifold gauge set. The center port line will be used later for both the HFC-410A and nitrogen containers.

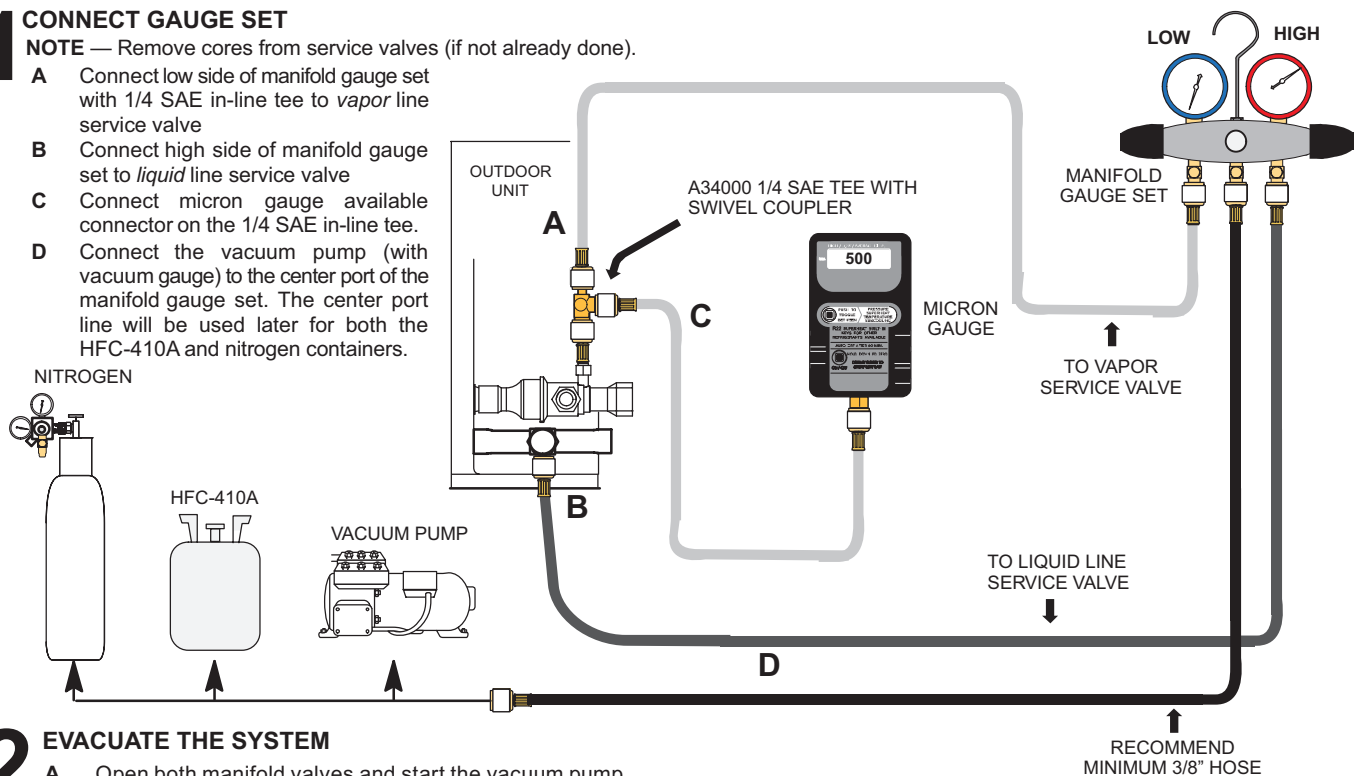

### 2 EVACUATE THE SYSTEM

- A** Open both manifold valves and start the vacuum pump.
- B** Evacuate the line set and indoor unit to an **absolute pressure** of 23,000 microns (29.01 inches of mercury).
 

**NOTE** — During the early stages of evacuation, it is desirable to close the manifold gauge valve at least once. A rapid rise in pressure indicates a relatively large leak. If this occurs, **repeat the leak testing procedure**.

**NOTE** — The term **absolute pressure** means the total actual pressure within a given volume or system, above the absolute zero of pressure. Absolute pressure in a vacuum is equal to atmospheric pressure minus vacuum pressure.
- C** When the absolute pressure reaches 23,000 microns (29.01 inches of mercury), perform the following:
  - Close manifold gauge valves
  - Close valve on vacuum pump
  - Turn off vacuum pump
  - Disconnect manifold gauge center port hose from vacuum pump
  - Attach manifold center port hose to a dry nitrogen cylinder with pressure regulator set to 150 psig (1034 kPa) and purge the hose.
  - Open manifold gauge valves to break the vacuum in the line set and indoor unit.
  - Close manifold gauge valves.
- D** Shut off the dry nitrogen cylinder and remove the manifold gauge hose from the cylinder. Open the manifold gauge valves to release the dry nitrogen from the line set and indoor unit.
- E** Reconnect the manifold gauge to the vacuum pump, turn the pump on, and continue to evacuate the line set and indoor unit until the absolute pressure does not rise above 500 microns (29.9 inches of mercury) within a 20-minute period after shutting off the vacuum pump and closing the manifold gauge valves.
- F** When the absolute pressure requirement above has been met, disconnect the manifold hose from the vacuum pump and connect it to an upright cylinder of HFC-410A refrigerant. Open the manifold gauge valve 1 to 2 psig in order to release the vacuum in the line set and indoor unit.
- G** Perform the following:
  - Close manifold gauge valves.
  - Shut off HFC-410A cylinder.
  - Reinstall service valve cores by removing manifold hose from service valve. Quickly install cores with core tool while maintaining a positive system pressure.
  - Replace stem caps and secure finger tight, then tighten an additional one-sixth (1/6) of a turn as illustrated.

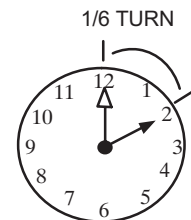

**FIGURE 13. Evacuating the System**

## ⚠ IMPORTANT

Use a thermocouple or thermistor electronic vacuum gauge that is calibrated in microns. Use an instrument capable of accurately measuring down to 50 microns.

## ⚠ WARNING

Possible equipment damage.

Avoid deep vacuum operation. Do not use compressors to evacuate a system. Extremely low vacuum can cause internal arcing and compressor failure. Damage caused by deep vacuum operation will void warranty.

Evacuating the system of non-condensables is critical for proper operation of the unit. Non-condensables are defined as any gas that will not condense under temperatures and pressures present during operation of an air conditioning system. Non-condensables and water suction combine with refrigerant to produce substances that corrode copper piping and compressor parts.

## Electrical – Circuit Sizing and Wire Routing

In the U.S.A., wiring must conform with current local codes and the current National Electric Code (NEC). In Canada, wiring must conform with current local codes and the current Canadian Electrical Code (CEC).

Refer to the furnace or air handler installation instructions for additional wiring application diagrams and refer to unit nameplate for minimum circuit ampacity and maximum overcurrent protection size.

### 24VAC TRANSFORMER

Use the transformer provided with the furnace or air handler for low-voltage control power (24VAC - 40 VA minimum).

## ⚠ WARNING

Fire Hazard. Use of aluminum wire with this product may result in a fire, causing property damage, severe injury or death. Use copper wire only with this product.

## ⚠ WARNING

Failure to use properly sized wiring and circuit breaker may result in property damage. Size wiring and circuit breaker(s) per Product Specifications bulletin (EHB) and unit rating plate.

### SIZE CIRCUIT AND INSTALL SERVICE DISCONNECT SWITCH

Refer to the unit nameplate for minimum circuit ampacity, and maximum fuse or circuit breaker (HACR per NEC). Install power wiring and properly sized disconnect switch.

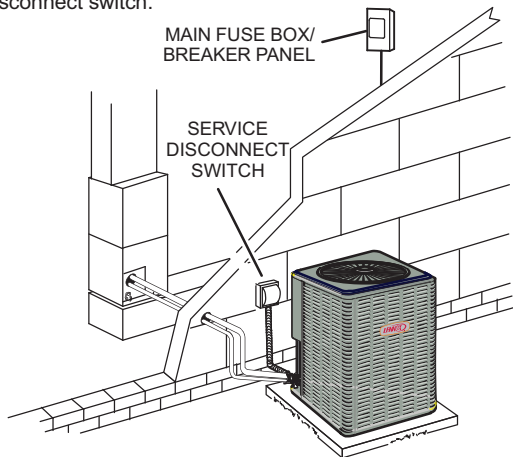

*NOTE — Units are approved for use only with copper conductors. Ground unit at disconnect switch or to an earth ground.*

### INSTALL THERMOSTAT

Install room thermostat (ordered separately) on an inside wall approximately in the center of the conditioned area and 5 feet (1.5m) from the floor. It should not be installed on an outside wall or where it can be affected by sunlight or drafts.

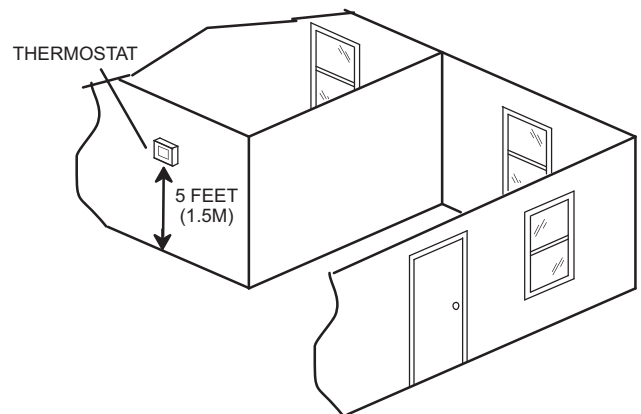



*NOTE — 24VAC, Class II circuit connections are made in the control panel.*

# ROUTING HIGH VOLTAGE/ GROUND AND CONTROL WIRING

## HIGH VOLTAGE / GROUND WIRES

Any excess high voltage field wiring should be trimmed and secured away from any low voltage field wiring. To facilitate a conduit, a cutout is located in the bottom of the control panel. Connect conduit to the control panel using a proper conduit fitting.

-  HIGH VOLTAGE FIELD WIRING
-  LOW VOLTAGE FIELD WIRING
-  FACTORY WIRING

## CONTROL WIRING

*NOTE* — Wire tie provides low voltage control wire strain relief and to maintain separation of field installed low and high voltage circuits.

*NOTE* — For proper voltages, select thermostat wire (control wires) gauge per table below.

*NOTE* — Do not bundle any excess 24VAC control wires inside control panel.

Install low voltage wiring from outdoor to indoor unit and from thermostat to indoor unit as illustrated.

- A** Run 24VAC control wires through hole with grommet and secure with provided wire tie.
- B** Make 24VAC thermostat wire connections. Locate the two wires from the contactor and make connection using field provided wire nuts:
  - Yellow to Y1
  - Black to C (common)

WIRE RUN LENGTH	AWG#	INSULATION TYPE
LESS THAN 100' (30 METERS)	18	TEMPERATURE RATING
MORE THAN 100' (30 METERS)	16	35°C MINIMUM.

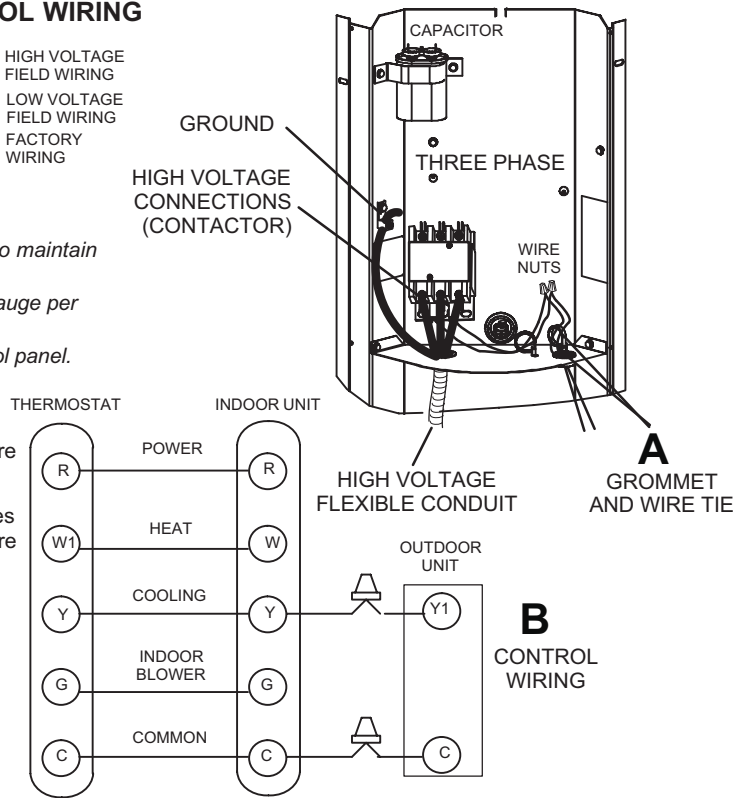

**FIGURE 14. Typical Wiring**

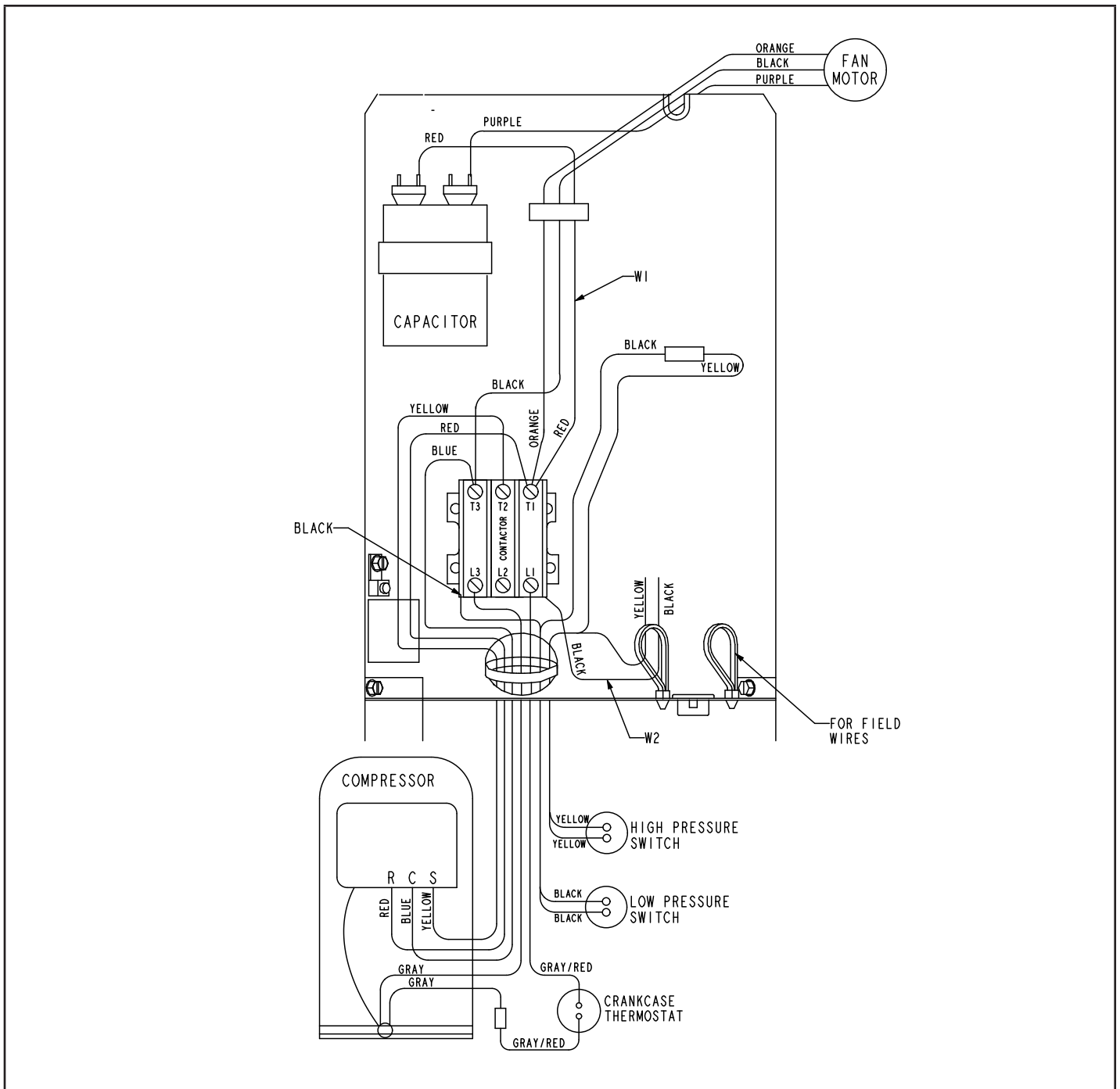
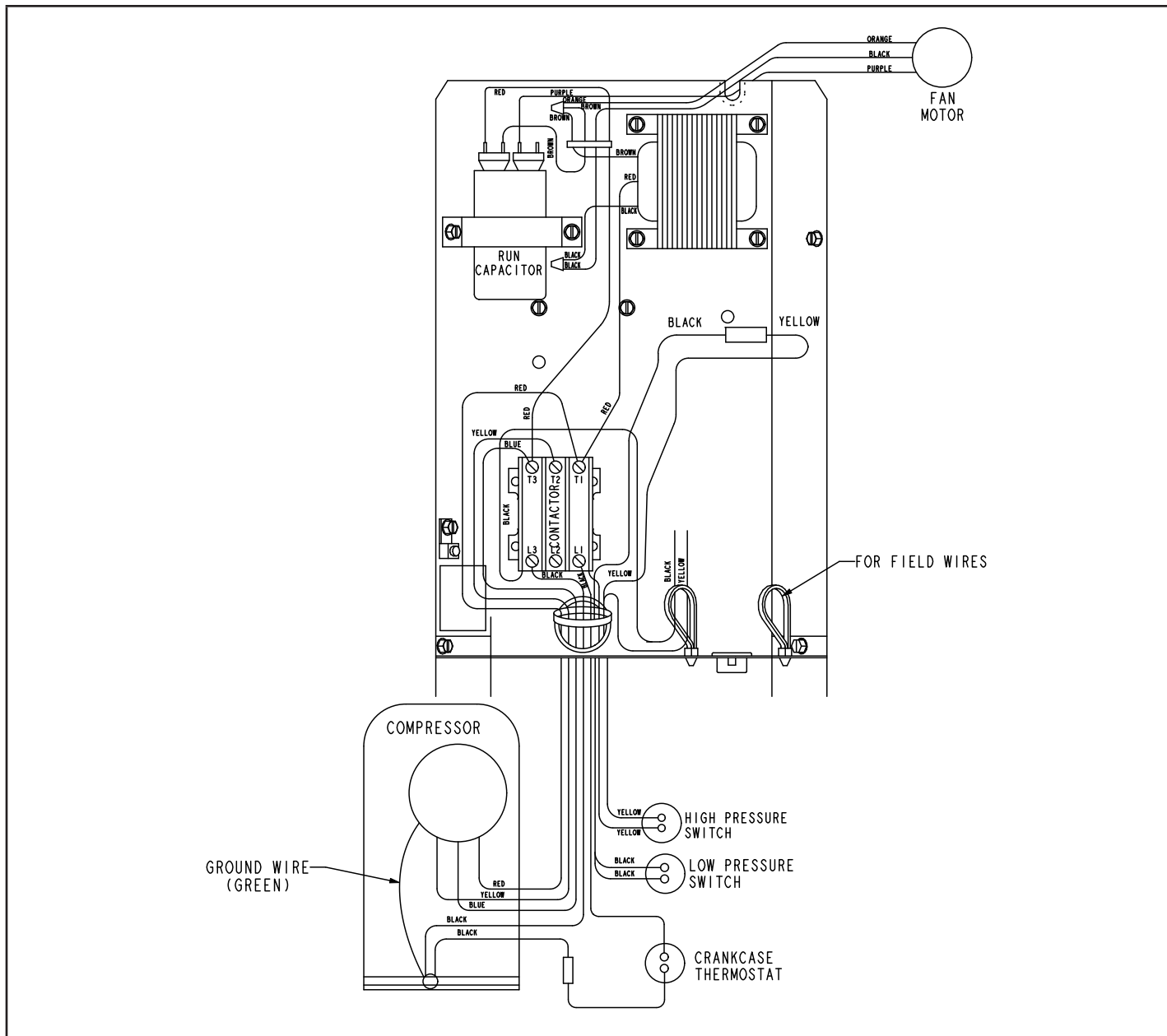

FIGURE 15. Typical Factory Wiring – G and Y Voltages



**FIGURE 16. Typical Factory Wiring – J Voltage**

## System Operation

### **IMPORTANT**

Some scroll compressors have an internal vacuum protector that will unload scrolls when suction pressure goes below 20 psig. A hissing sound will be heard when the compressor is running unloaded. Protector will reset when low pressure in system rises above 40 psig. **DO NOT REPLACE COMPRESSOR.**

The outdoor unit and indoor blower will cycle on and off as dictated by demands from the room thermostat. When the thermostat's blower switch is in the **ON** position, the indoor blower will operate continuously.

#### **HIGH PRESSURE SWITCH (S4)**

ML14XC1 units are equipped with a high-pressure switch that is factory-wired and located in the liquid line.

The switch is a Single Pole, Single Throw (SPST), auto-reset switch which is normally closed and removes power from the compressor when discharge pressure rises above factory setting at  $590 \pm 10$  psig; resets at  $418 \pm 5$  psig.

#### **CRANKCASE HEATER (HR1) AND THERMOSTAT (S40)**

Compressors in some models are equipped with a 40 watt or 70 watt, belly band type crankcase heater. HR1 prevents liquid from accumulating in the compressor. HR1 is controlled by a single pole, single through thermostat switch (S40) located on the liquid line (see figure 1 for location).

When liquid line temperature drops below  $50^\circ\text{F}$  the thermostat closes energizing HR1. The thermostat will open, de-energizing HR1 once liquid line temperature reaches  $70^\circ\text{F}$ .

#### **THERMAL PROTECTION SWITCH (S173) - COMPRESSOR MOUNTED**

Some units are equipped with a compressor mounted normally closed temperature switch that prevents compressor damage due to overheating caused by internal friction. The switch is located on top of the compressor casing. This switch senses the compressor casing temperature and opens at  $239\text{-}257^\circ\text{F}$  ( $115^\circ\text{C}\text{-}125^\circ\text{C}$ ) to shut off compressor operation. The auto-reset switch closes when the compressor casing temperature falls to  $151\text{-}187^\circ\text{F}$  ( $66^\circ\text{C}\text{-}86^\circ\text{C}$ ), and the compressor is re-energized. This single-pole, single-throw (SPST) bi-metallic switch is wired in series with the 24V Y input signal to control compressor operation.

## Maintenance

Your heating and air conditioning system should be inspected and maintained yearly (before the start of the cooling and heating seasons) by a licensed professional HVAC technician. You can expect the technician to check the following items. **These checks may only be conducted by a licensed professional HVAC technician.**

## Outdoor Unit

1. Inspect component wiring for loose, worn or damaged connections. Also check for any rubbing or pinching of wires. Confirm proper voltage plus amperage of outdoor unit.
2. Check the cleanliness of outdoor fan and blade assemblies. Check condition of fan blades (cracks). Clean or replace them, if necessary.
3. Inspect base pan drains for debris and clean as necessary.
4. Inspect the condition of refrigerant piping and confirm that pipes are not rubbing copper-to-copper. Also, check the condition of the insulation on the refrigerant lines. Repair, correct, or replace as necessary.
5. Test capacitor. Replace as necessary.
6. Inspect contactor contacts for pitting or burn marks. Replace as necessary.
7. Check outdoor fan motor for worn bearings/bushings. Replace as necessary.
8. Inspect and clean outdoor coils, if necessary and note any damage to coils or signs of leakage.

### **NOTICE !**

**Failure to follow instructions will cause damage to the unit.**

**This unit is equipped with an aluminum coil. Aluminum coils may be damaged by exposure to solutions with a pH below 5 or above 9. The aluminum coil should be cleaned using potable water at a moderate pressure (less than 50psi). If the coil cannot be cleaned using water alone, Lennox recommends use of a coil cleaner with a pH in the range of 5 to 9. The coil must be rinsed thoroughly after cleaning.**

**In coastal areas, the coil should be cleaned with potable water several times per year to avoid corrosive buildup (salt).**

## Indoor Unit (Air Handler or Furnace)

1. Inspect component wiring for loose, worn or damaged connections. Confirm proper voltage plus amperage indoor unit.
2. Inspect and clean or replace air filters in indoor unit.
3. Check the cleanliness of indoor blower and clean blower, if necessary.
4. Inspect the evaporator coil (Indoor) drain pans and condensate drains for rust, debris, obstructions, leaks or cracks. Pour water in pans to confirm proper drainage from the pan through to the outlet of the pipe. Clean or replace as necessary.
5. Inspect and clean evaporator (indoor) coil, if necessary.
6. Inspect the condition of the refrigerant lines and confirm that pipes are not rubbing copper-to-copper. Also, ensure that refrigerant pipes are not being affected by indoor air contamination. Check condition of insulation on the refrigerant lines. Repair, correct, or replace as necessary.



7. Inspect the duct system for leaks or other problems. Repair or replace as necessary.
8. Check for bearing/bushing wear on indoor blower motor. Replace as necessary.
9. Indoor unit inspections of gas- or oil-fired furnaces will also include inspection and cleaning of the burners, and a full inspection of the gas valve, heat exchanger and flue (exhaust) system.

### General System Test with System Operating

1. Your technician should perform a general system test. He will turn on the air conditioner to check operating functions such as the startup and shutoff operation. He will also check for unusual noises or odors, and measure indoor/outdoor temperatures and system pressures as needed.
2. The technician will check the refrigerant charge per the charging sticker information on the outdoor unit.
3. Verify that system total static pressure and airflow settings are within specific operating parameters.
4. Verify correct temperature drop across indoor coil.

Start-Up and Performance Checklist			
Job Name _____	Job no. _____	Date _____	
Job Location _____	City _____	State _____	
Installer _____	City _____	State _____	
Unit Model No. _____	Serial No. _____	Service Technician _____	
Nameplate Voltage _____			
Rated Load Ampacity _____	Compressor _____	Outdoor Fan _____	
Maximum Fuse or Circuit Breaker _____			
Electrical Connections Tight? <input type="checkbox"/>	Indoor Filter clean? <input type="checkbox"/>	Supply Voltage (Unit Off) _____	
Indoor Blower RPM _____	S.P. Drop Over Indoor (Dry) _____	Outdoor Coil Entering Air Temp. _____	
Discharge Pressure _____	Suction Pressure _____	Refrigerant Charge Checked? <input type="checkbox"/>	
<b>Refrigerant Lines:</b> - Leak Checked? <input type="checkbox"/>		Properly Insulated? <input type="checkbox"/>	Outdoor Fan Checked? <input type="checkbox"/>
<b>Service Valves:</b> --- Fully Opened? <input type="checkbox"/>		Caps Tight? <input type="checkbox"/>	
Voltage With Compressor Operating _____		<b>Thermostat</b>	
		Calibrated? <input type="checkbox"/>	Properly Set? <input type="checkbox"/> Level? <input type="checkbox"/>

## Typical Field Wiring

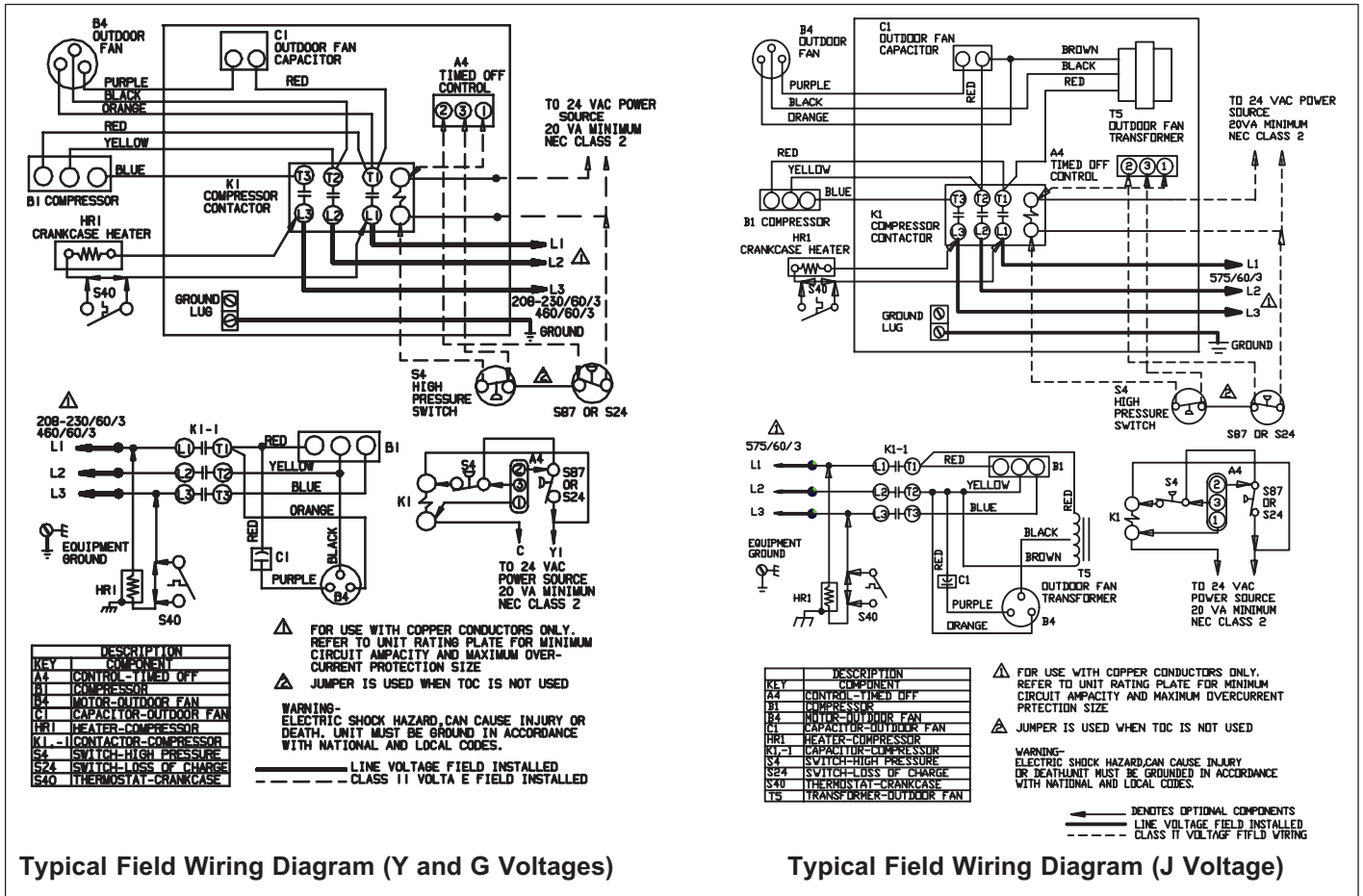

FIGURE 17. Typical Field Wiring

**NOTE** – The thermostat used may be electromechanical or electronic.

**NOTE** – Transformer in indoor unit supplies power (24 VAC) to the thermostat and outdoor unit controls.

### COOLING:

- Cooling demand initiates at Y1 in the thermostat.
- 24VAC from indoor unit (Y1) energizes the TOC timed off control (if used) which energizes contactor K1 (provided S4 high pressure switch is closed).
- K1-1 N.O. closes, energizing compressor (B1) and outdoor fan motor (B4).
- Compressor (B1) and outdoor fan motor (B4) begin immediate operation..

### END OF COOLING DEMAND:

- Cooling demand is satisfied. Terminal Y1 is de-energized .
- Compressor contactor K1 is de-energized.
- K1-1 opens and compressor (B1) and outdoor fan motor (B4) are de-energized and stop immediately

## Servicing Units Delivered Void of Charge

If the outdoor unit is void of refrigerant, clean the system using the procedure described below.

- Leak test the system using the procedure outlined on page 18.
- Evacuate the system using procedure outlined on page 19.
- Use nitrogen to break the vacuum and install a new filter drier in the system.
- Evacuate the system again using procedure outlined on page 19.
- Weigh in refrigerant using procedure outlined in figure 20.

## Unit Start-Up

### **⚠ IMPORTANT**

If unit is equipped with a crankcase heater, it should be energized 24 hours before unit start-up to prevent compressor damage as a result of slugging.

- 1 - Rotate fan to check for binding.
- 2 - Inspect all factory- and field-installed wiring for loose connections.
- 3 - After evacuation is complete, open both the liquid and vapor line service valves to release the refrigerant charge (contained in outdoor unit) into the system.
- 4 - Replace the stem caps and tighten to the value listed in table 1.
- 5 - Check voltage supply at the disconnect switch. The voltage must be within the range listed on the unit's nameplate. If not, do not start the equipment until you have consulted with the power company and the voltage condition has been corrected.

- 6 - Set the thermostat for a cooling demand. Turn on power to the indoor unit and close the outdoor unit disconnect switch to start the unit.
- 7 - Recheck voltage while the unit is running. Power must be within range shown on the nameplate.
- 8 - Check system for sufficient refrigerant by using the procedures that follow.

## System Refrigerant

This section outlines procedures for:

- 1 - Connecting gauge set for testing and charging;
- 2 - Checking and adjusting indoor airflow;
- 3 - Adding or removing refrigerant.

NOTE - System fault and lockout codes take precedence over system status codes (cooling, heating operating percentages or defrost/dehumidification).

# GAUGE SET

## CONNECTIONS FOR TESTING AND CHARGING

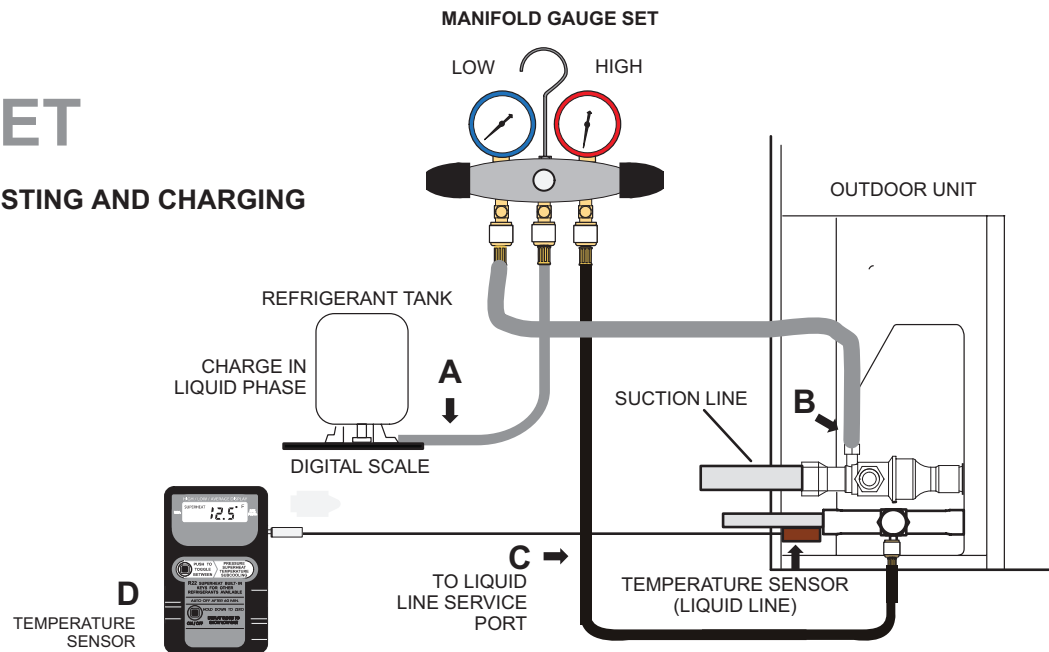

- A. CLOSE MANIFOLD GAUGE SET VALVES AND CONNECT THE CENTER HOSE TO A CYLINDER OF HFC-410A SET FOR LIQUID PHASE CHARGING.
- B. CONNECT THE MANIFOLD GAUGE SET'S LOW PRESSURE SIDE TO THE SUCTION LINE SERVICE PORT.
- C. CONNECT THE MANIFOLD GAUGE SET'S HIGH PRESSURE SIDE TO THE LIQUID LINE SERVICE PORT.
- D. POSITION TEMPERATURE SENSOR ON LIQUID LINE NEAR LIQUID LINE SERVICE PORT.

**FIGURE 18. Gauge Set Setup and Connections**

## ADDING OR REMOVING REFRIGERANT

This system uses HFC-410A refrigerant which operates at much higher pressures than HCFC-22. The pre-installed liquid line filter drier is approved for use with HFC-410A only. Do not replace it with components designed for use with HCFC-22. This unit is NOT approved for use with coils which use capillary tubes or fixed orifices as a refrigerant metering device. Check airflow using the Delta-T (DT) process using the illustration in figure 19.

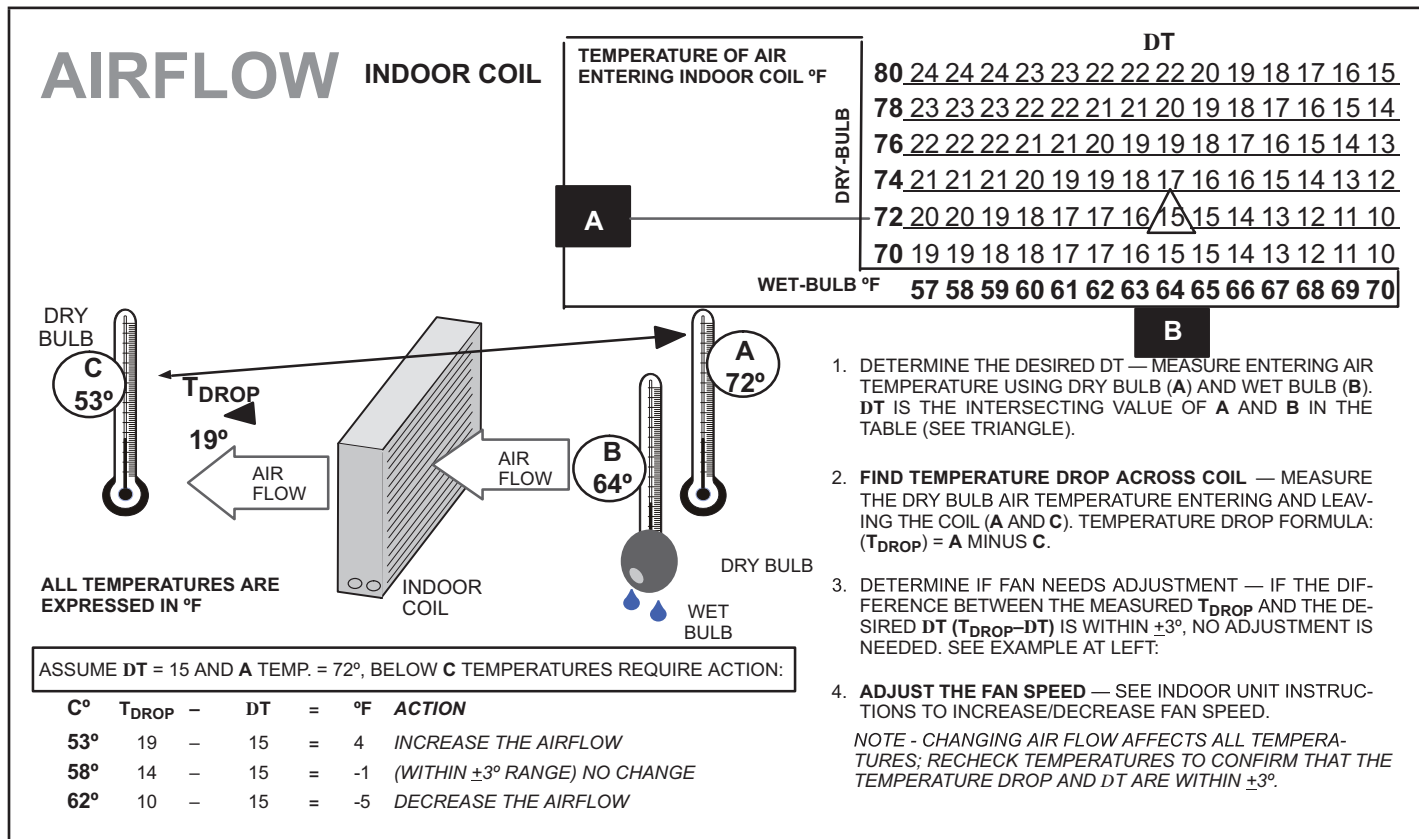

FIGURE 19. Checking Indoor Airflow over Evaporator Coil using Delta-T Chart

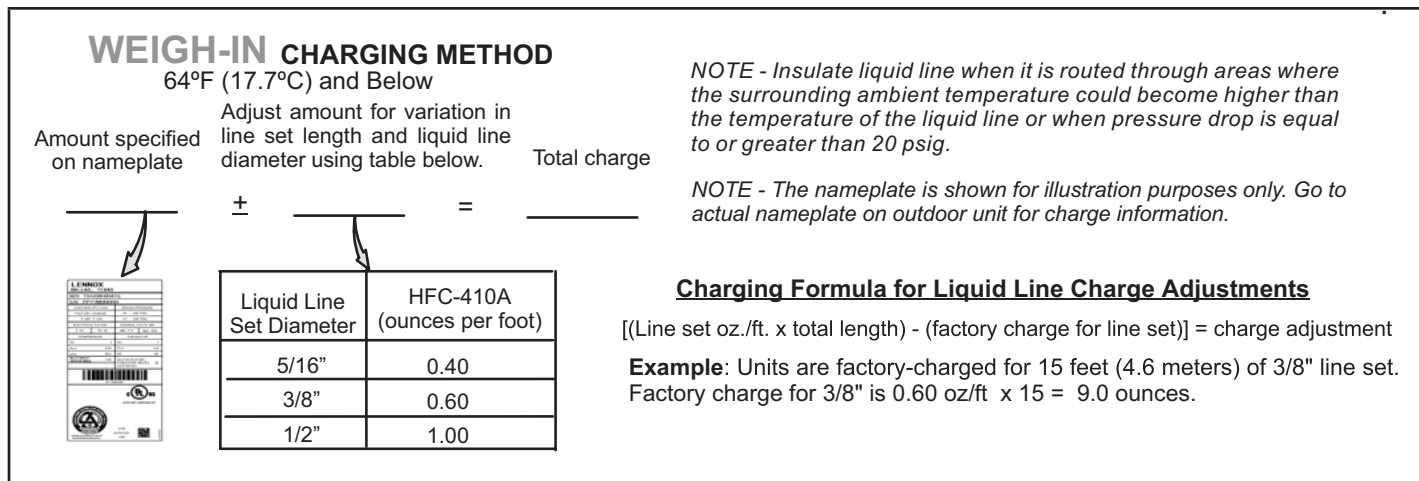
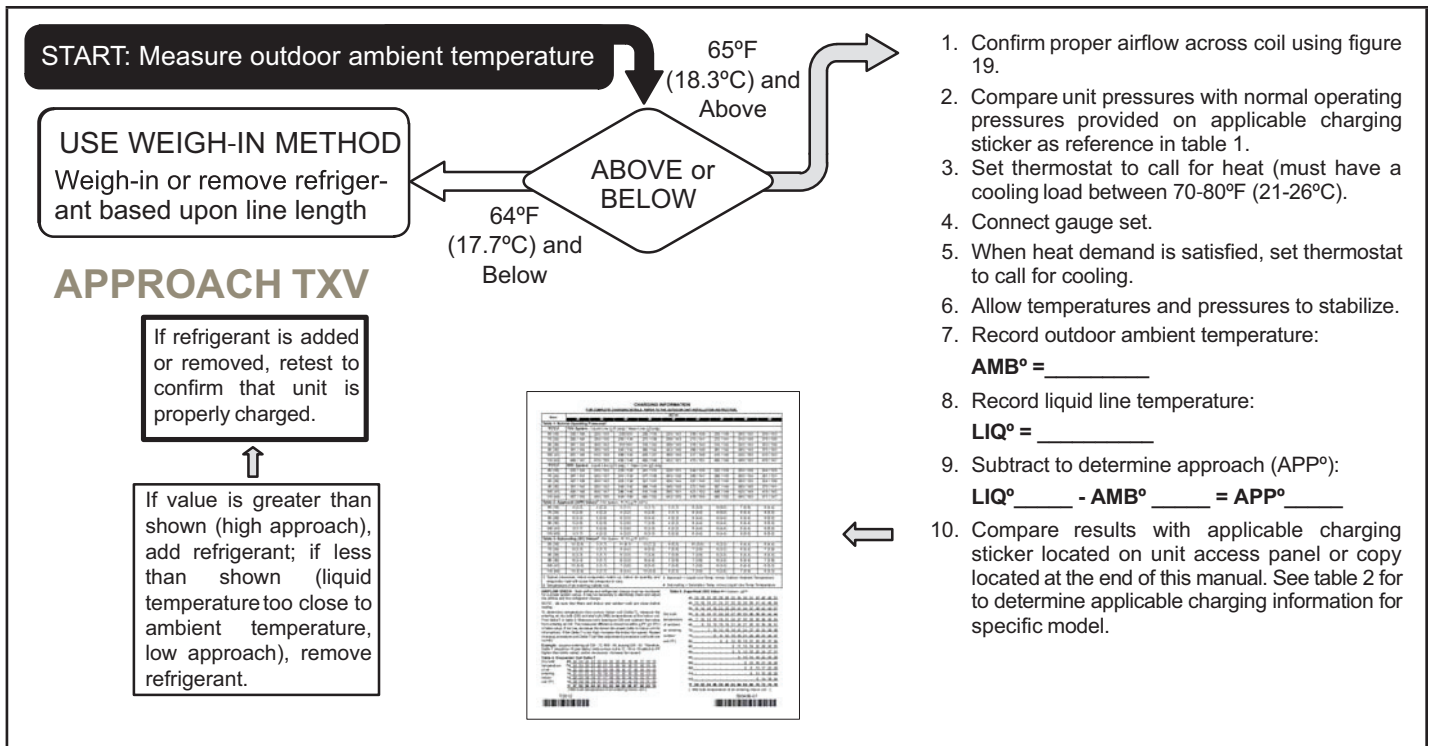
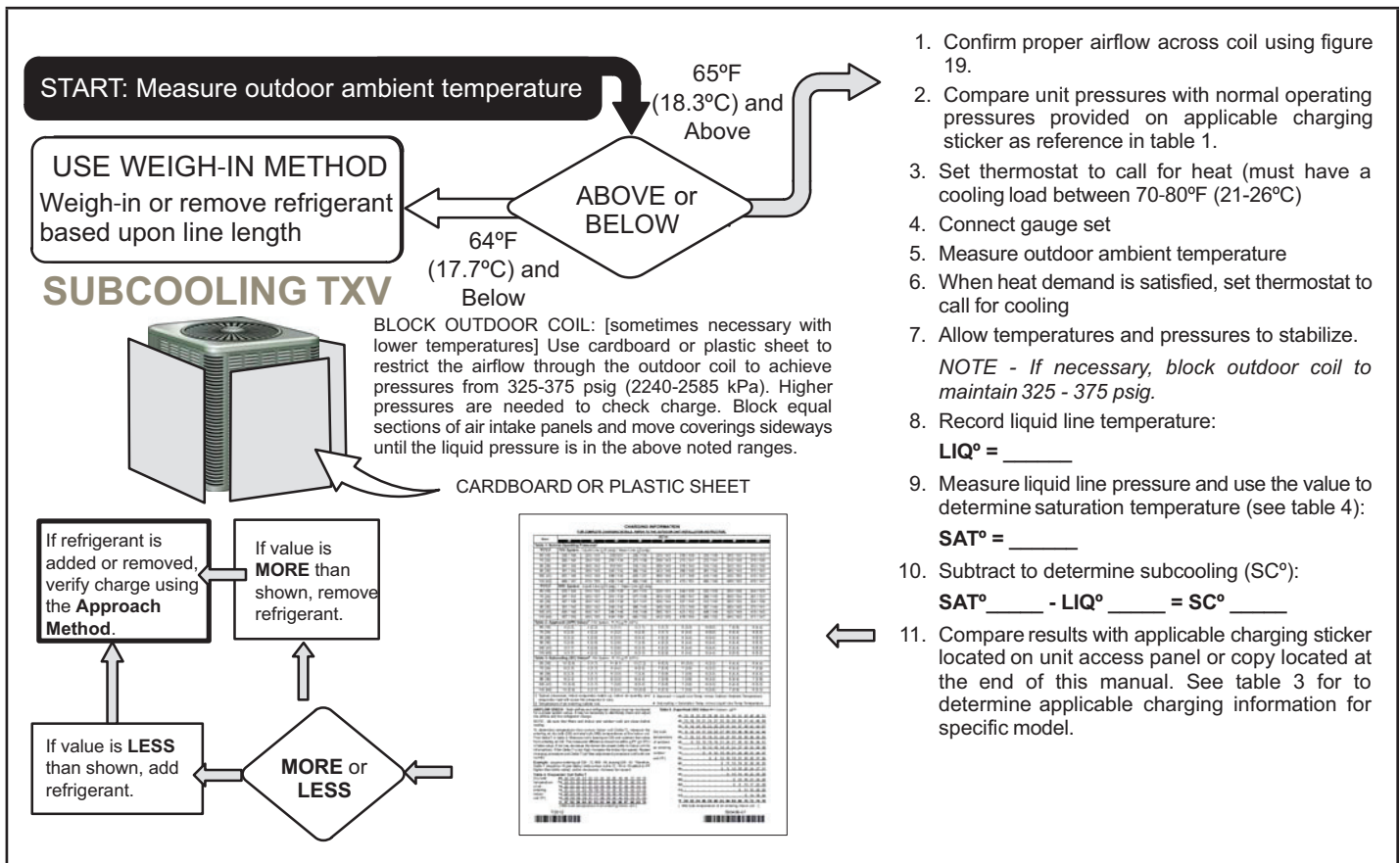

FIGURE 20. Using HFC-410A Weigh-In Method



**FIGURE 21. HFC-410A Approach TXV Charge**



**FIGURE 22. HFC-410A Subcooling TXV Charge**

**TABLE 3. HFC-410A Temperature – Pressure (Psig)**

<b>°F</b>	<b>°C</b>	<b>Psig</b>	<b>°F</b>	<b>°C</b>	<b>Psig</b>
-40	-40.0	11.6	60	15.6	170
-35	-37.2	14.9	65	18.3	185
-30	-34.4	18.5	70	21.1	201
-25	-31.7	22.5	75	23.9	217
-20	-28.9	26.9	80	26.7	235
-15	-26.1	31.7	85	29.4	254
-10	-23.3	36.8	90	32.2	274
-5	-20.6	42.5	95	35.0	295
0	-17.8	48.6	100	37.8	317
5	-15.0	55.2	105	40.6	340
10	-12.2	62.3	110	43.3	365
15	-9.4	70.0	115	46.1	391
20	-6.7	78.3	120	48.9	418
25	-3.9	87.3	125	51.7	446
30	-1.1	96.8	130	54.4	476
35	1.7	107	135	57.2	507
40	4.4	118	140	60.0	539
45	7.2	130	145	62.8	573
50	10.0	142	150	65.6	608
55	12.8	155			