

COMPONENTS

(A) Top Panel-1pc

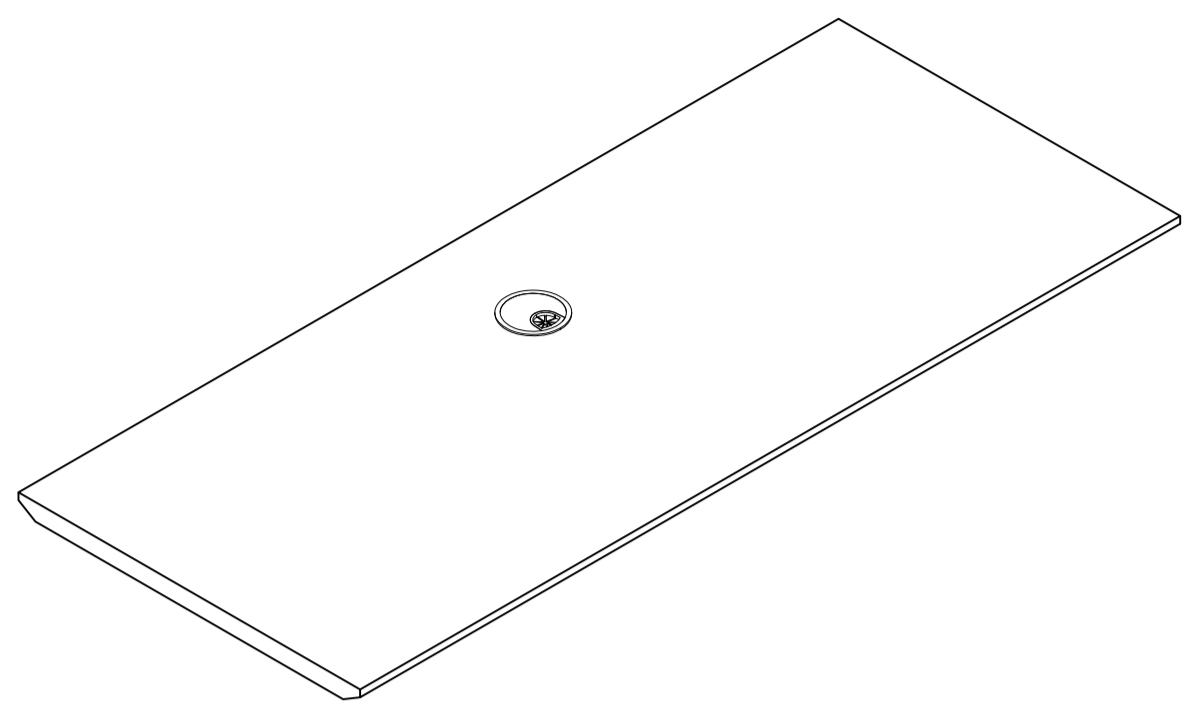

(B) Base Leg-1pc

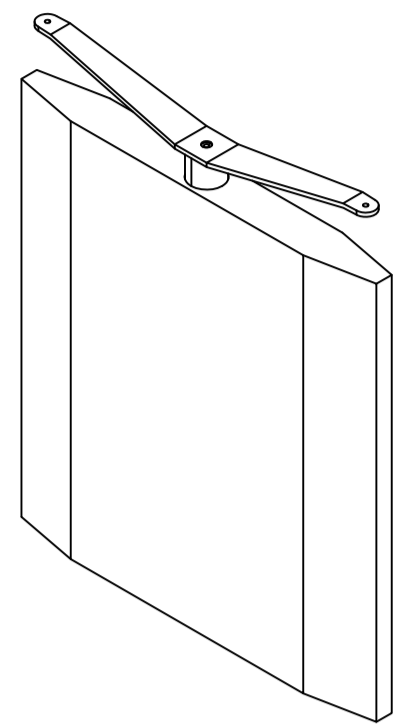

HARDWARE & TOOLS

(C) Mntg Bracket  
150\*90\*3mm-4pcs

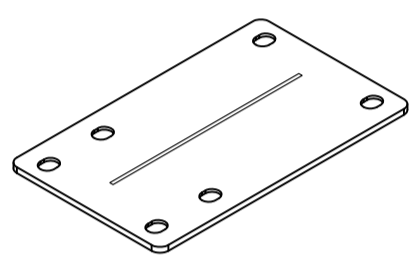

(D) Phillips Screw  
M6X15mm-25pcs

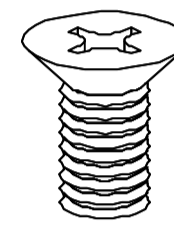

(E) Allen Screw  
M6X15mm-3pcs

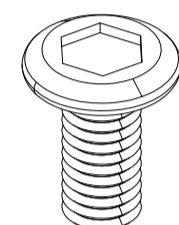

(F) Allen Wrench 4mm-1pc Tools Required for Assembly

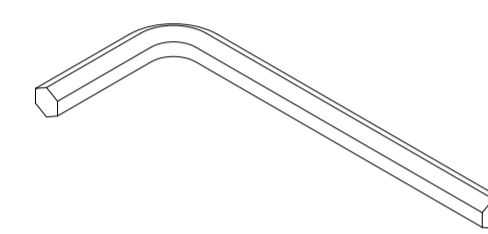

**NOTE:**  
Hardware is packed  
with carton **ALBB**

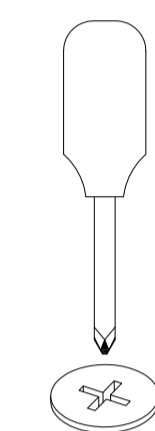

Phillips Screw Driver for  
(D) Screw Ø6X15mm

INSTRUCTIONS - Do not use power tools to assemble

STEP 1

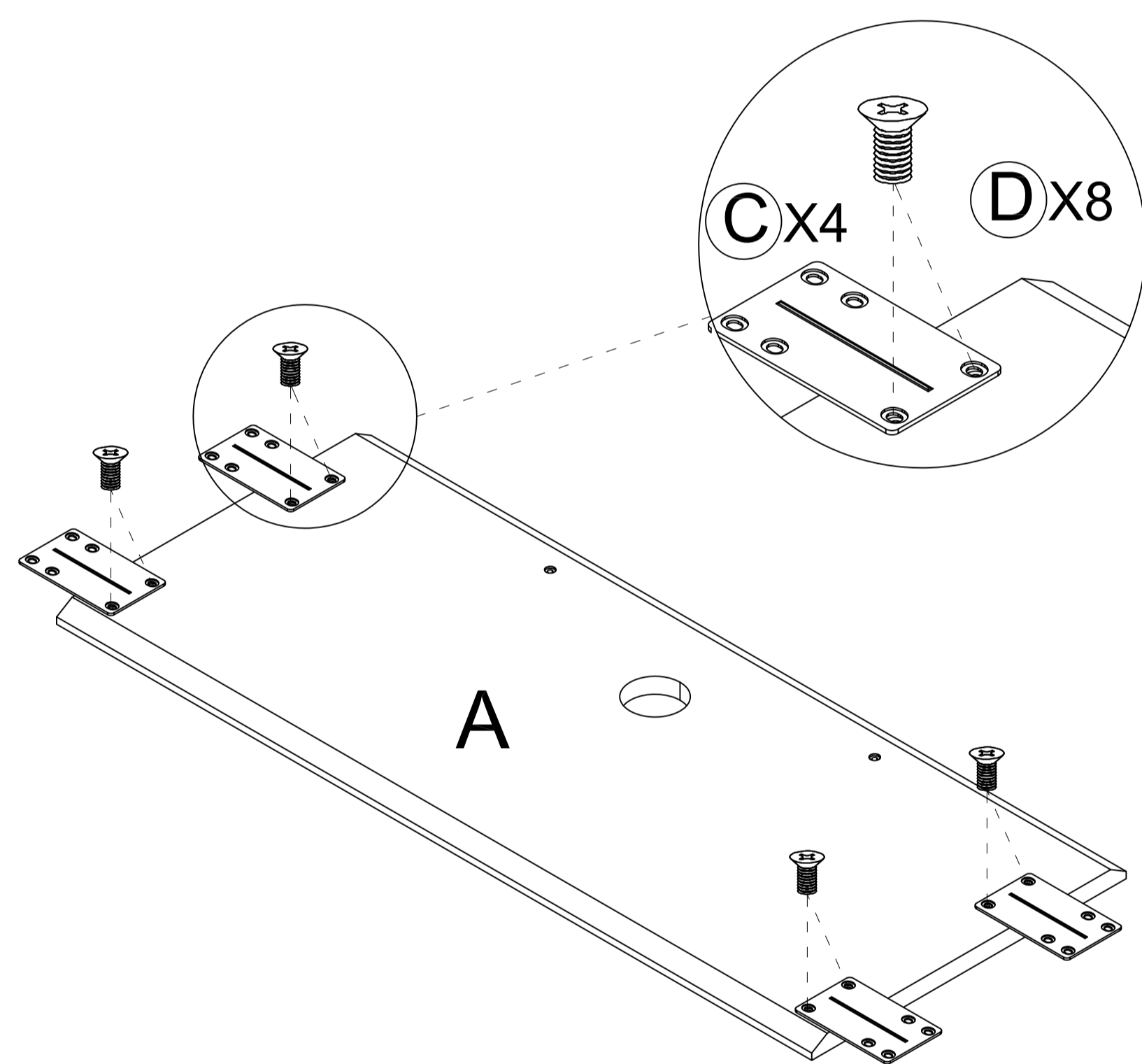

STEP 2

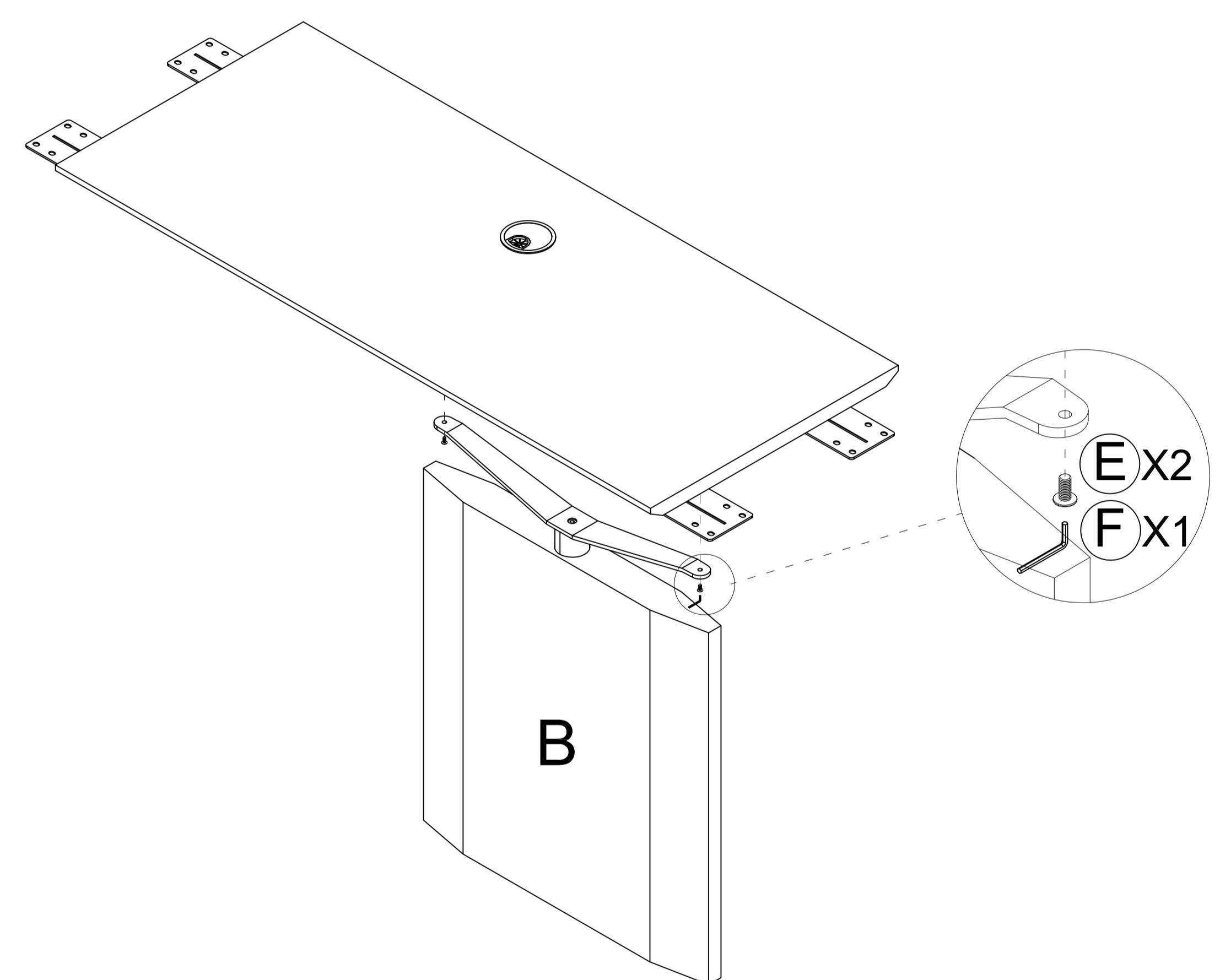

STEP 3 - Install Right or Left Side

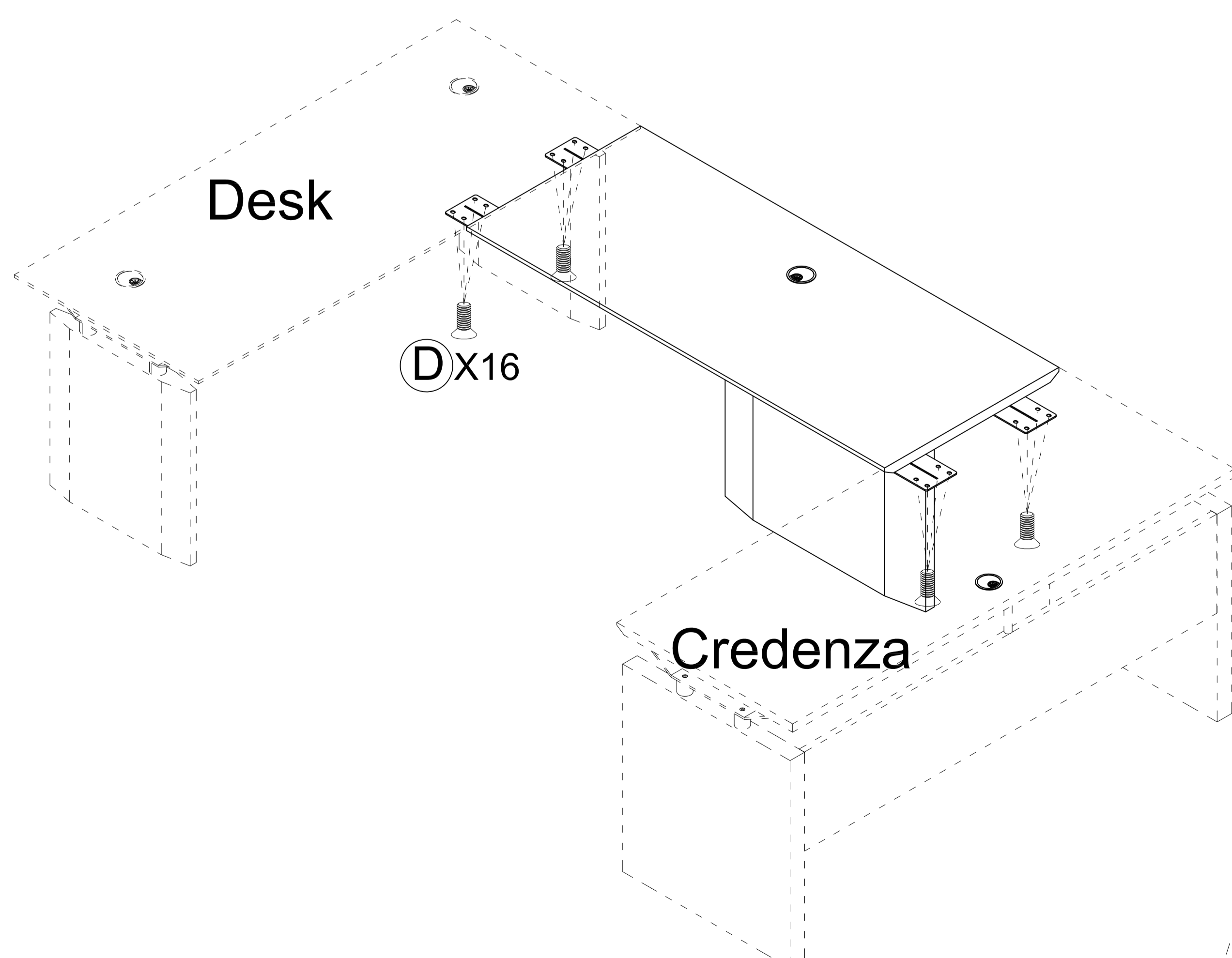

OR

