

Congratulations on the purchase of your new Officient chair!

PARTS

PART	DESCRIPTION	QTY
1	Left Metal Frame	1
2	Right Metal Frame	1
3	Cross Braces	2
4	Seat Cushion	1
5	1¾" Lock Tight Screws	4
6	1" Lock Tight Screws	4
7	Back Cushion	1
8	Back Flap	1
9	Hexagonal Wrench	1

INSTRUCTIONS

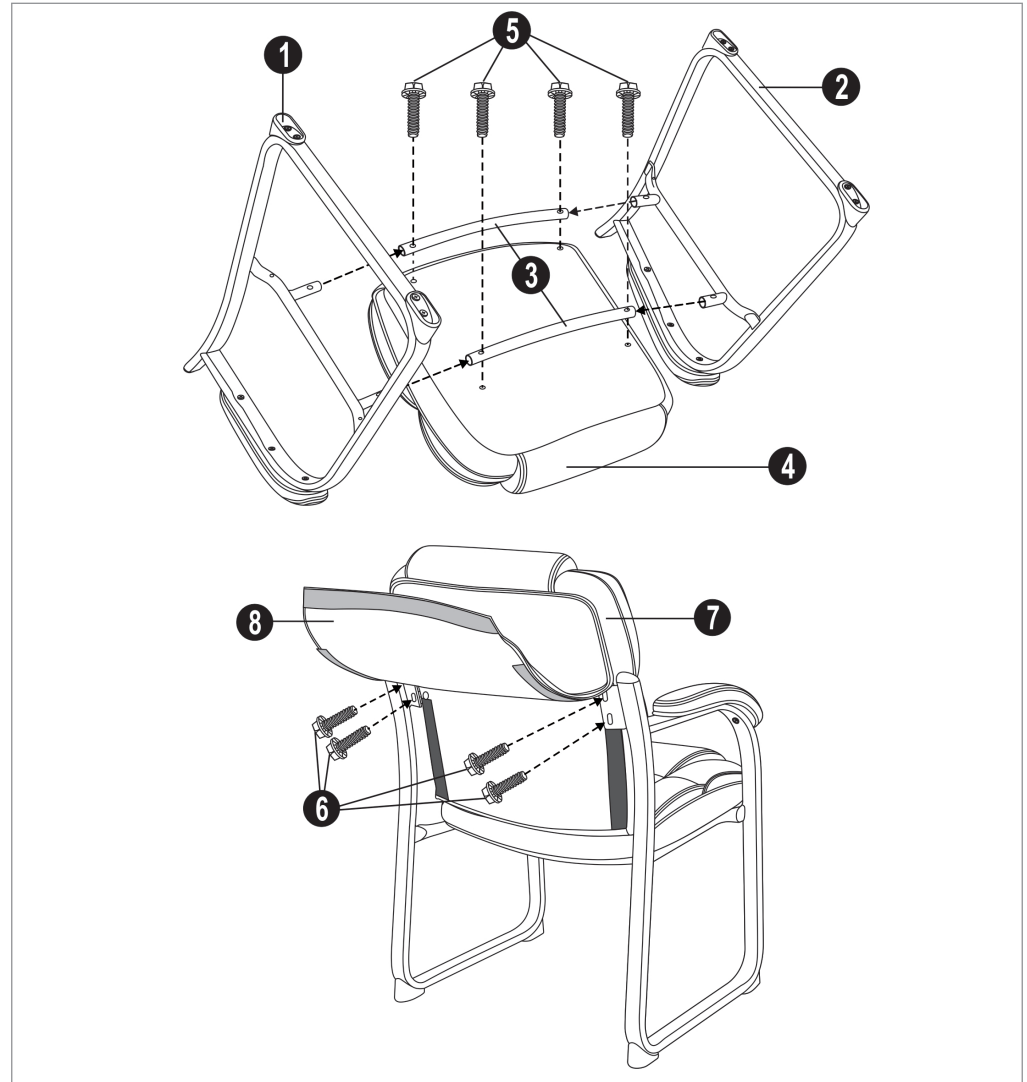

INSTRUCTIONS

- Remove all parts from the carton and separate them into part number groups as indicated in the parts list.
- Connect the two metal frames (1 & 2) with the cross braces (3) by inserting the pins on each frame into the braces (3). Attach the seat cushion (4) to cross braces (3) by using 1¾" lock tight screws (5). **Do not tighten screws completely.**
- Attach back cushion (7) to metal frames (1 & 2) by using 1" lock tight screws (6). **Do not tighten screws completely.** By leaving them slightly loose, you will be able to align them first.
- Adjust the chair so the seat and back cushions are aligned and the frame is sitting flat on the floor.
- Now tighten all of the screws completely.**
- Pull down the back flap (8) tightly and attach the back flap (8) to the velcro on the bottom of the seat cushion (4).
- Periodically (every 90 days) make sure that the screws are still fully tightened.

ATTENTION:

Make certain to fully tighten all screws before using chair.

WE SUGGEST TAPING THE WRENCH UNDER THE SEAT FOR FUTURE USE.