

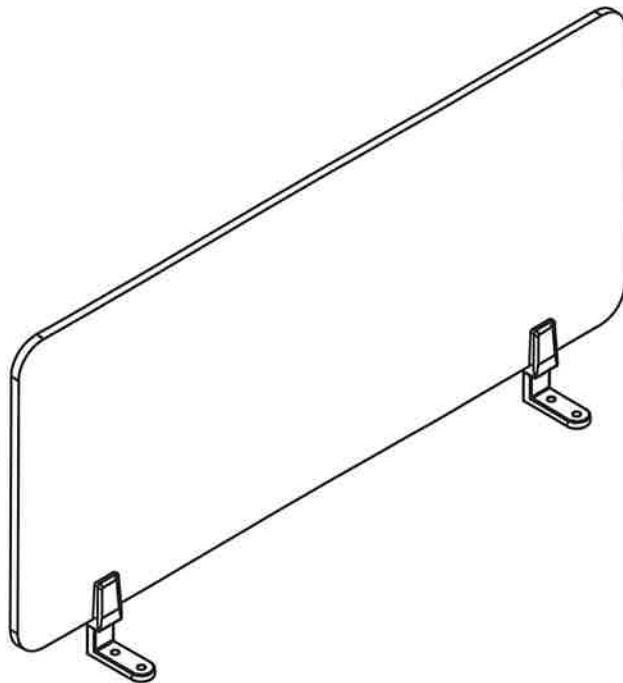

# NBF





## 46" 58" 70" Desktop Divider Assembly Instructions



O-ETP-46  
O-ETP-58  
O-ETP-70

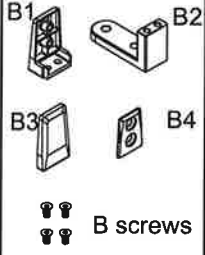

Assembly HARDWARE

S/N	PICTURE	NAME	TOTAL QTY	REMARK
A		Wrench	1PCS	
B		L support Bracket	2PCS	
C		Screw	4PCS	

FOLLOW STEPS 1 TO 3 FOR PANEL SETUP. SEE STEPS 4 TO 5 FOR INDIVIDUAL DESK INSTALLATION.

1. INSTALL "B1" AND "B2" L SUPPORT BRACKET PIECES TOGETHER USING "A" WRENCH.

A(1x)  
B1(2X)  
B2(2X)

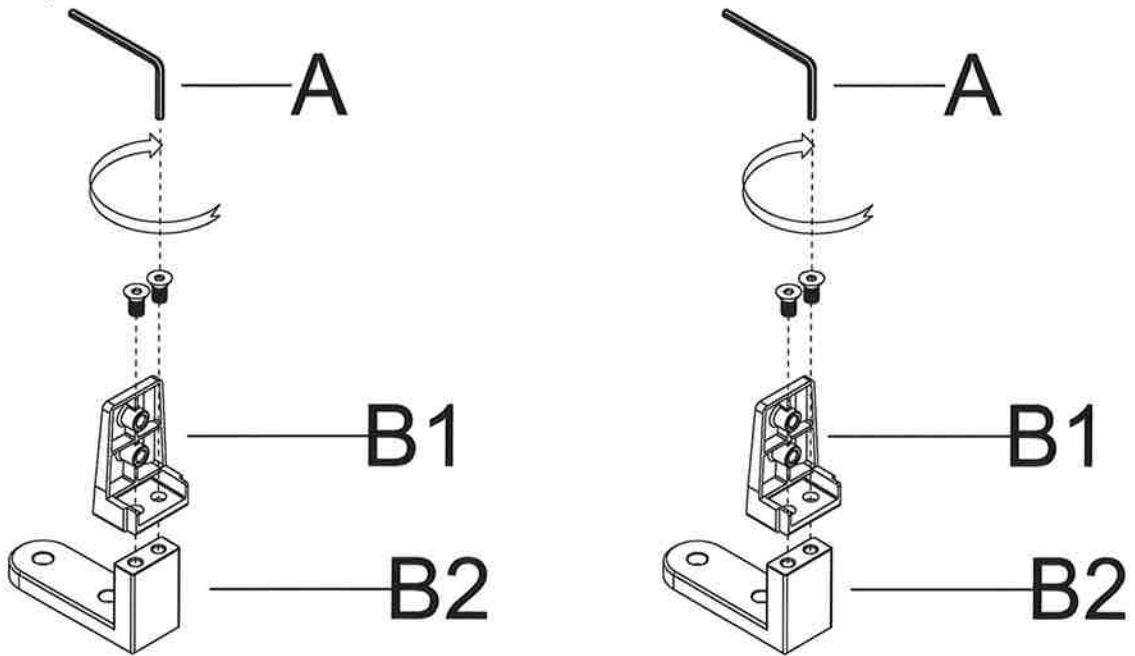

2. INSTALL "B" L SUPPORT BRACKETS TO THE BOTTOM OF DIVIDER USING "A" WRENCH AND "B4" AND "B" SCREWS.

A(1X)  
B4(2X)  
B SCREWS(4X)

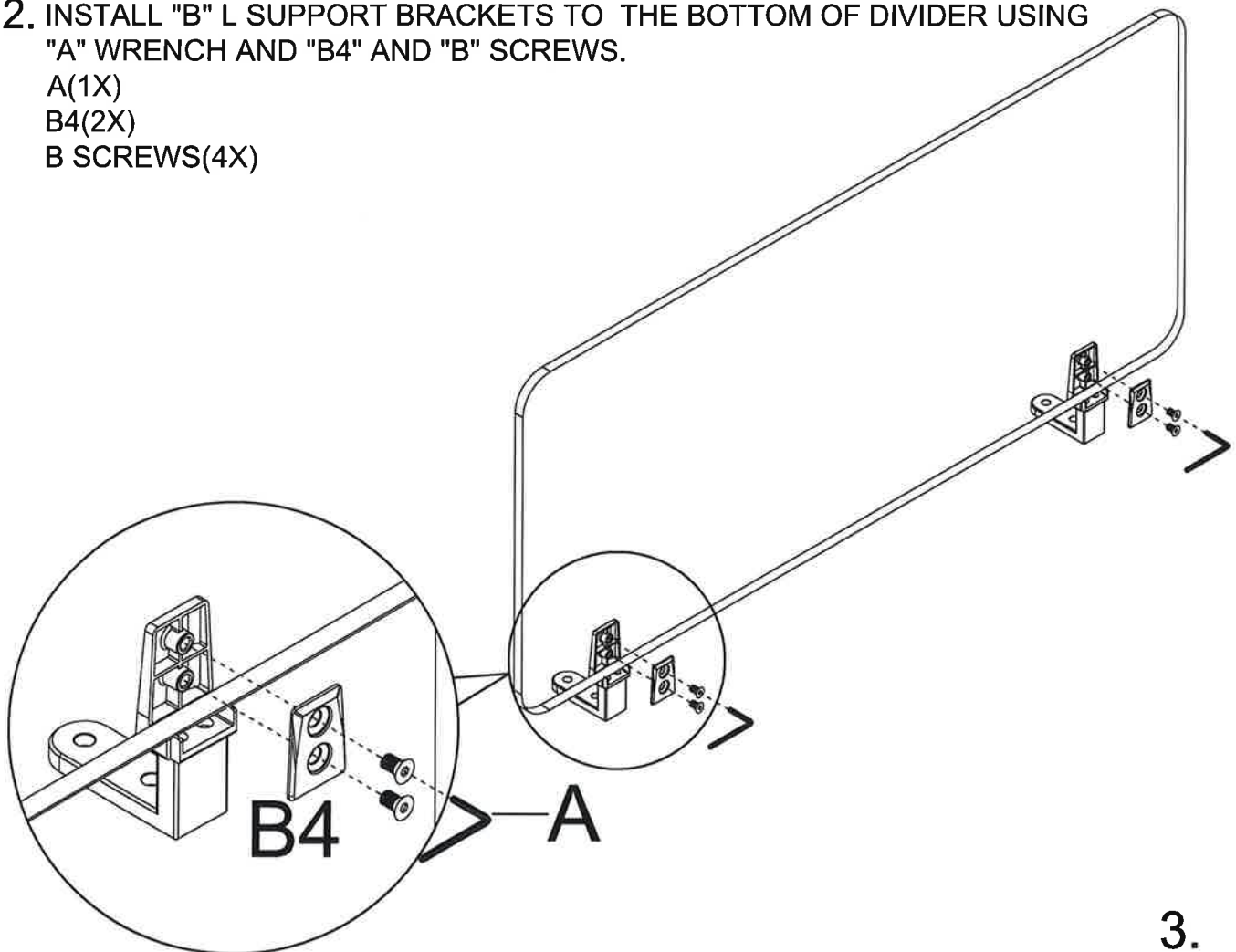

3.

3. PUSH DOWN "B3" OF L SUPPORT BRACKETS OVER "B4" TO COVER HOLES.  
B3(2X)

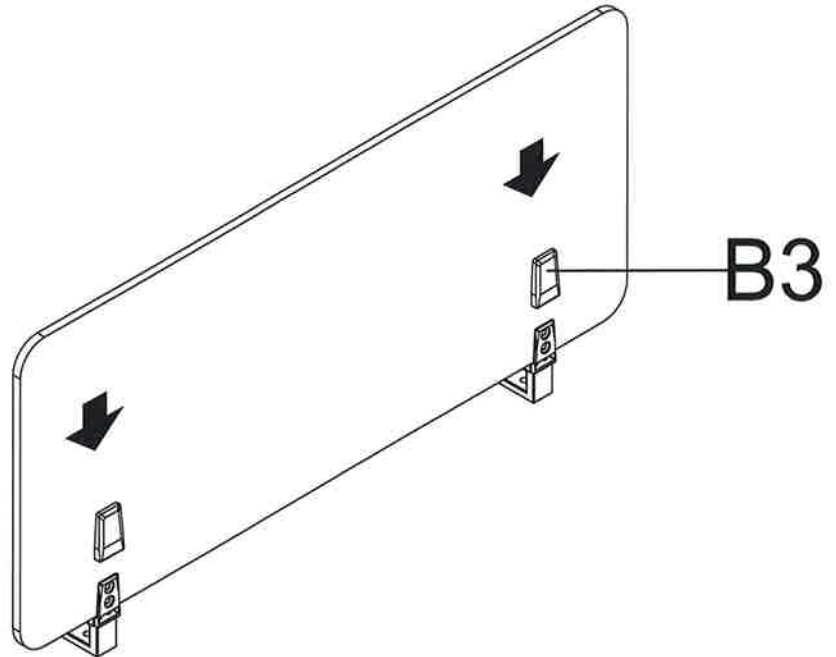

4. INSTALL DIVIDER TO AN INDIVIDUAL 71" OR 59" DESK USING "C" SCREWS.  
SLIDING BRACKET BETWEEN TOP AND FRAME. 2 SCREWS PER BRACKET.  
USE POWER DRILL FOR CONNECTION.  
C(4x)

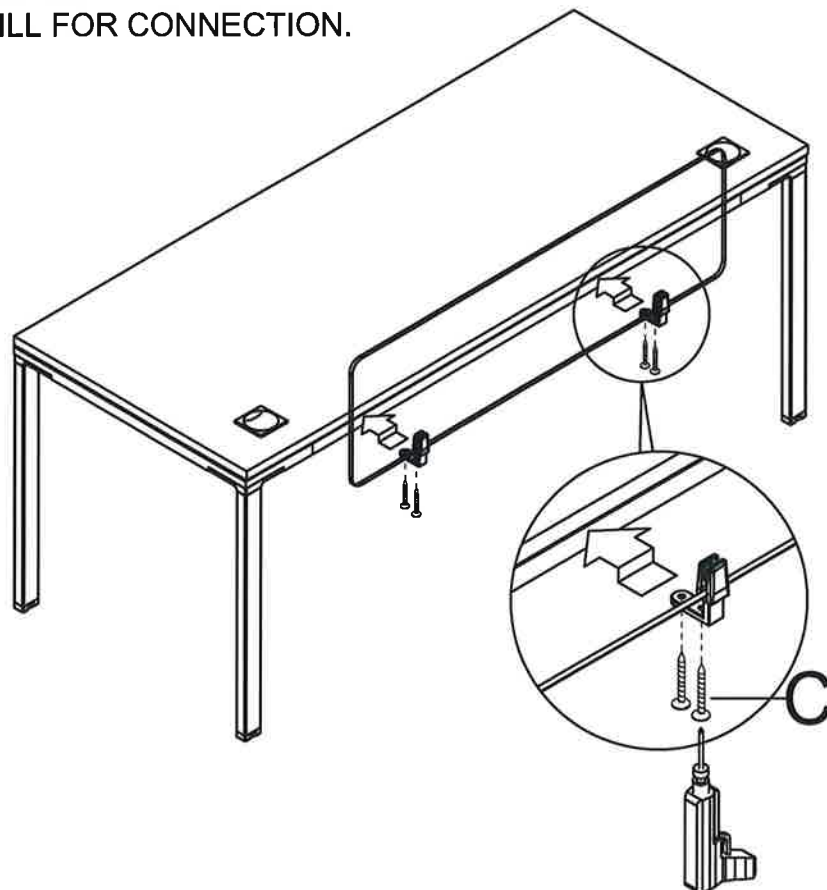

## 5. COMPLETE

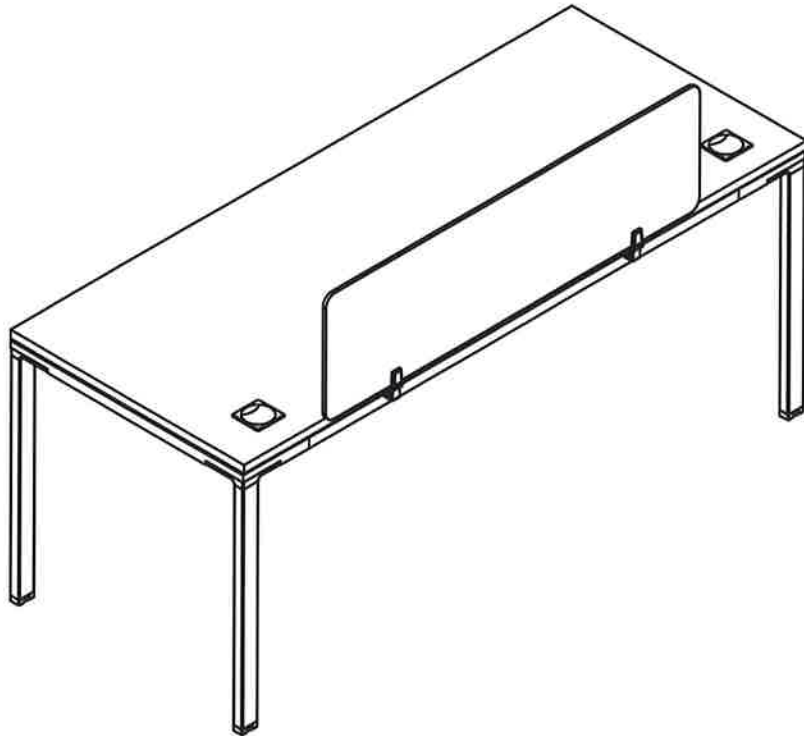

FOLLOW STEPS 6 TO 8 FOR TWO PERSON WORKSTATION INSTALLATION.

6. INSTALL DIVIDER TO 47" OR 59" WORKSTATION USING "C" SCREWS. SLIDING BRACKET BETWEEN TOP AND FRAME, 2 SCREWS PER BRACKET. USE POWER DRILL FOR CONNECTION.  
C(4X)

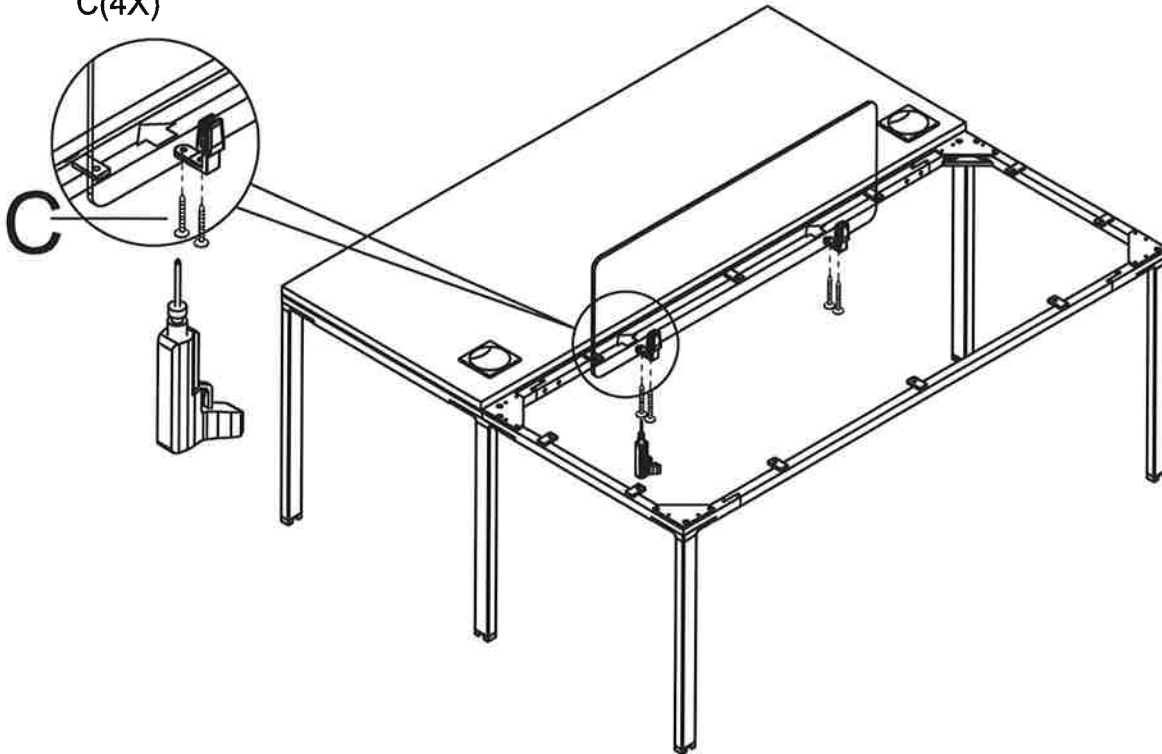

IMPORTANT: FOR WORKSTATION, INSTALL ONE DESK TOP FIRST, THEN DIVIDER, THEN SECOND DESKTOP LAST.

7. PUT ON THE OTHER DESK TOP, SEE WORKSTATION INSTRUCTIONS.

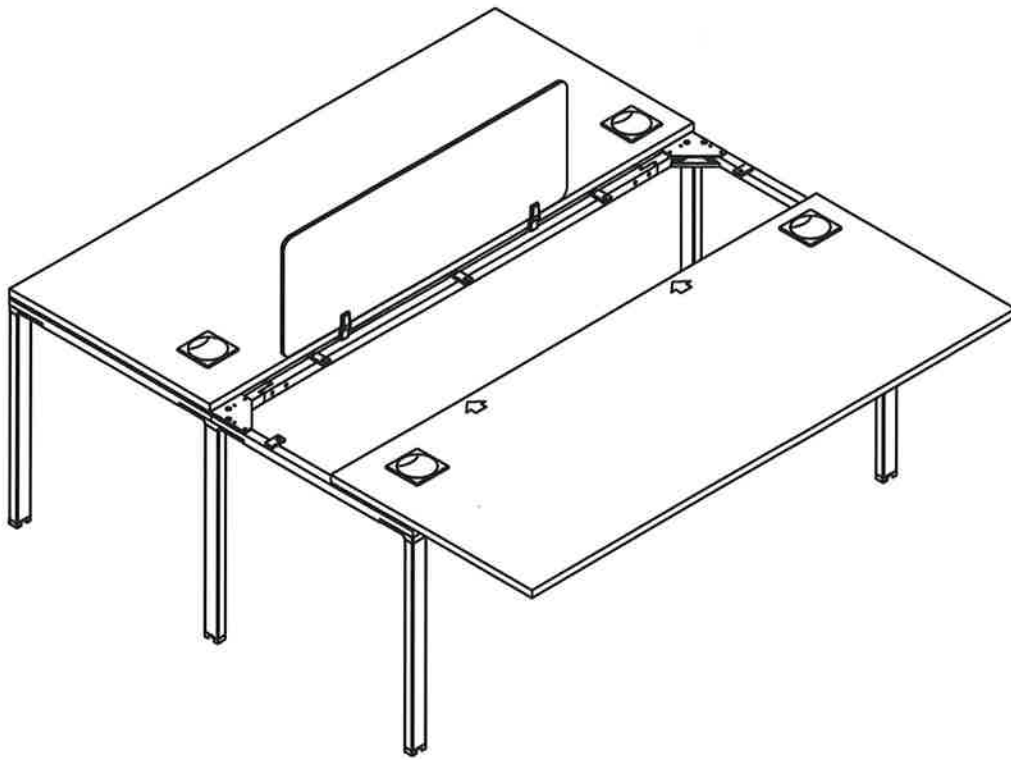

8. COMPLETE

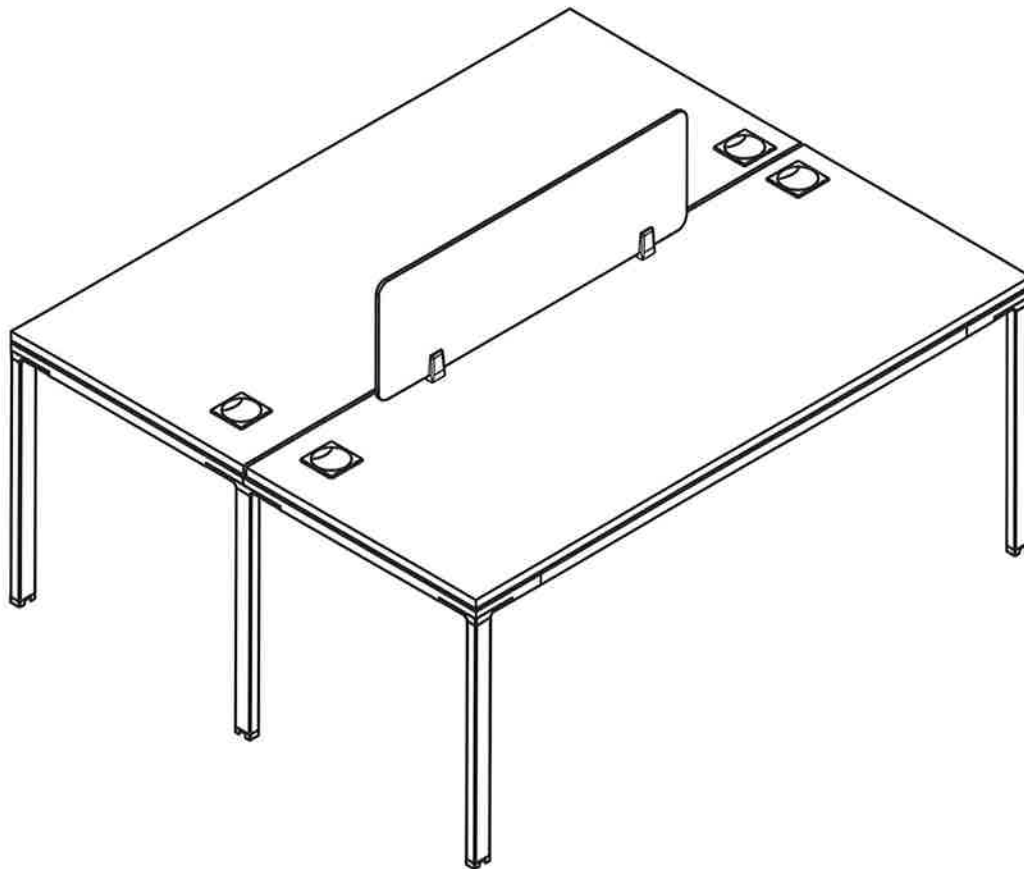

6.