



Signature Series

800-558-1010

www.NBF.com

Assembly
Instructions

AtWork Divider

Model# AW-50212-96
(96" x 78")

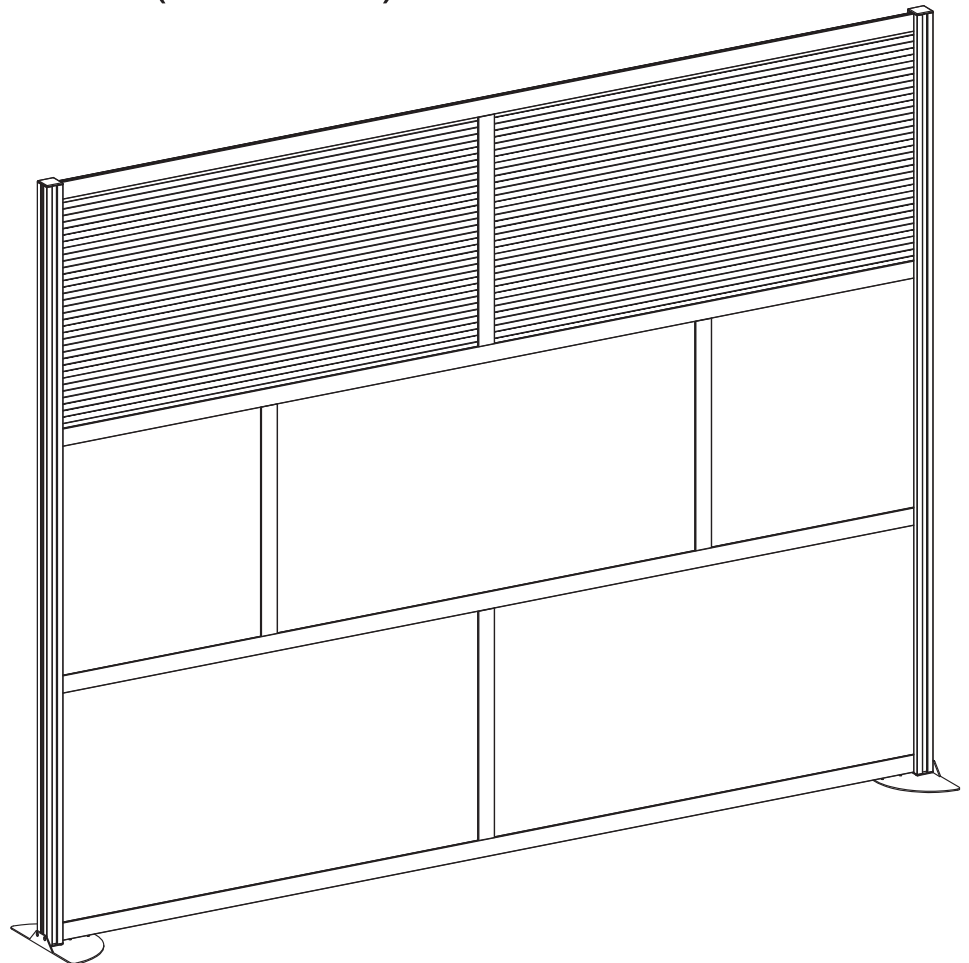

Do not return to store. For product support, please call toll free 866-606-7888

AtWork Divider

Model# AW-50212-96

(96" x 78")

Identify all the components

Carton A.

A. Plexi Glass Inserts 46"-2pcs
(AW-PG46)

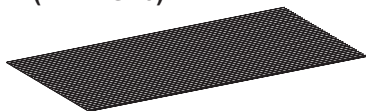

B. Cherry Inserts 22"-2pcs
(AW-CH22)

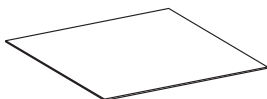

C. Cherry Inserts 46"-1pc
(AW-CH46)

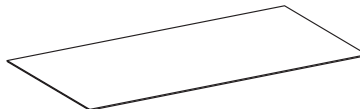

D. Espresso Inserts 46"-2pcs
(AW-ES46)



Carton B.

E. Frame -2pcs
(AW-50212-XX-FR)

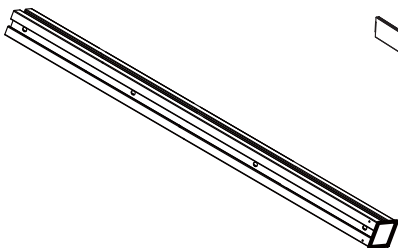

F. Horizontal Bar -4pcs
(AW-50212-72-HB)

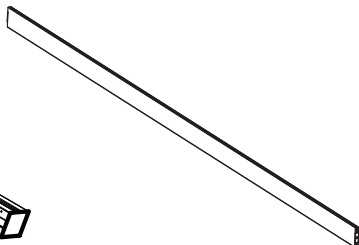

G. Vertical Bar -4pcs
(AW-50211-XX-VB)

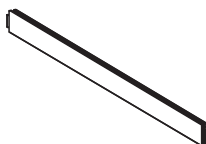

H. Duck Feet -2pcs
(AW-50211-48-DF)



Hardware identification

Carton B.

Z1. Bolt M6*60mm -8pcs
(AW-Bolt M6*60mm)

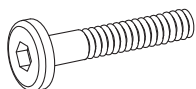

Z2. Bolt M6*15mm -4pcs
(AW-Bolt M6*15mm)

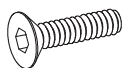

Z3. Screws 4*12mm -4pcs
(AW- Screws 4*12mm)



Z4. Screws 4*38mm -4pcs
(AW-Screws 4*38mm)

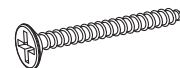

Z5. Allen Key- 1pc
(AW-Allen Wrench)

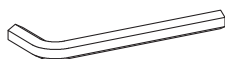

Z6. EVA 100mm -2pcs
(AW-50212-Z6)

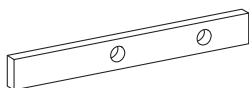

Z7. Top Cap -2pcs
(AW-Top Cap)

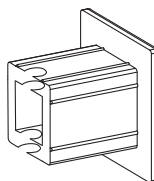

Z8. Bottom Cap (Pre-attached) -2pcs
(AW-Bottom Cap)

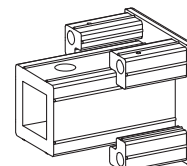

Step 1

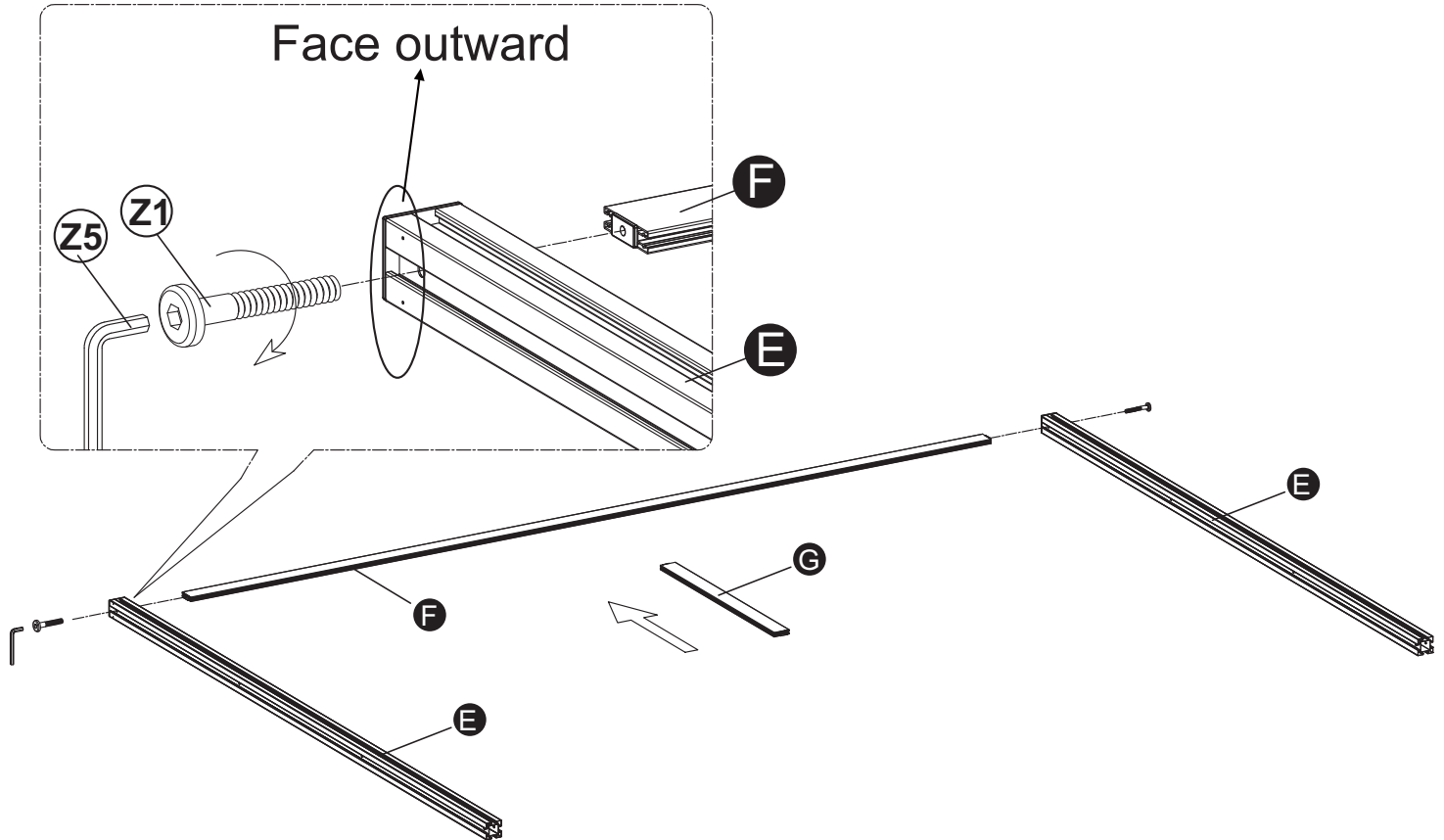

Z1. Bolt M6*60mm
- 2pcs

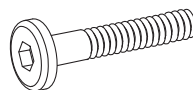

Z8. Bottom Cap (Pre-attached)
- 2pcs

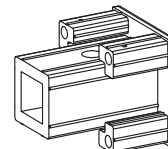

Z5. Allen Key
- 1pc



Note: Do not tighten screws until all screws have been started.

Step 2

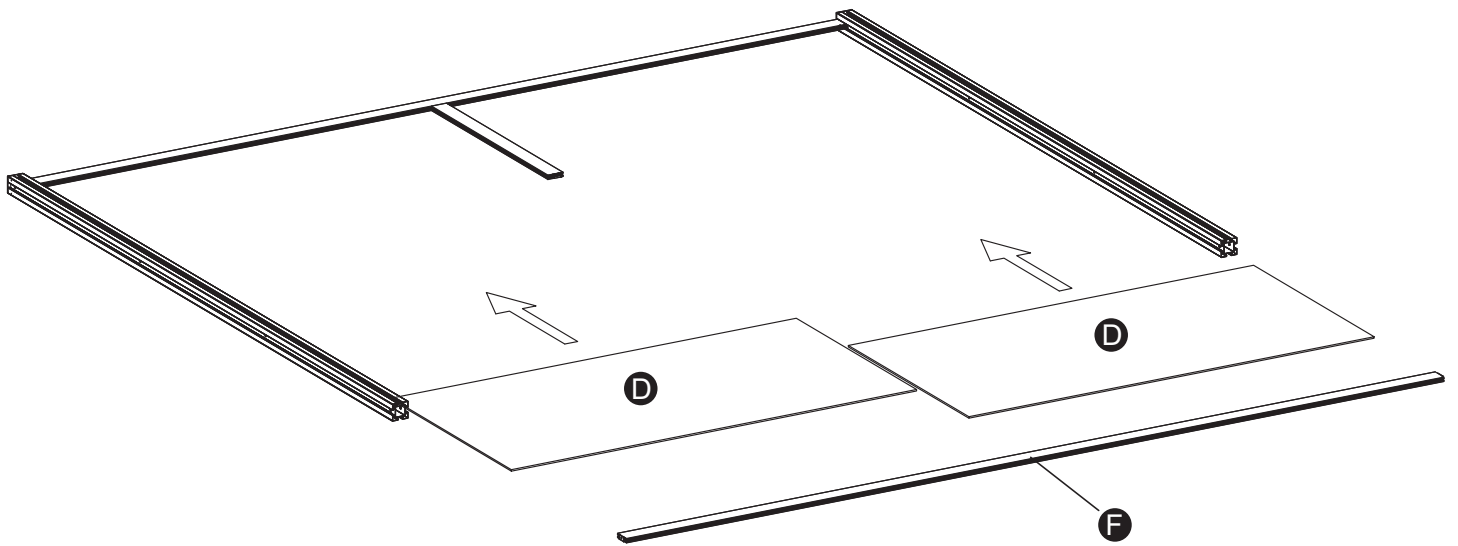

Note: Do not tighten screws until all screws have been started.

Step 3

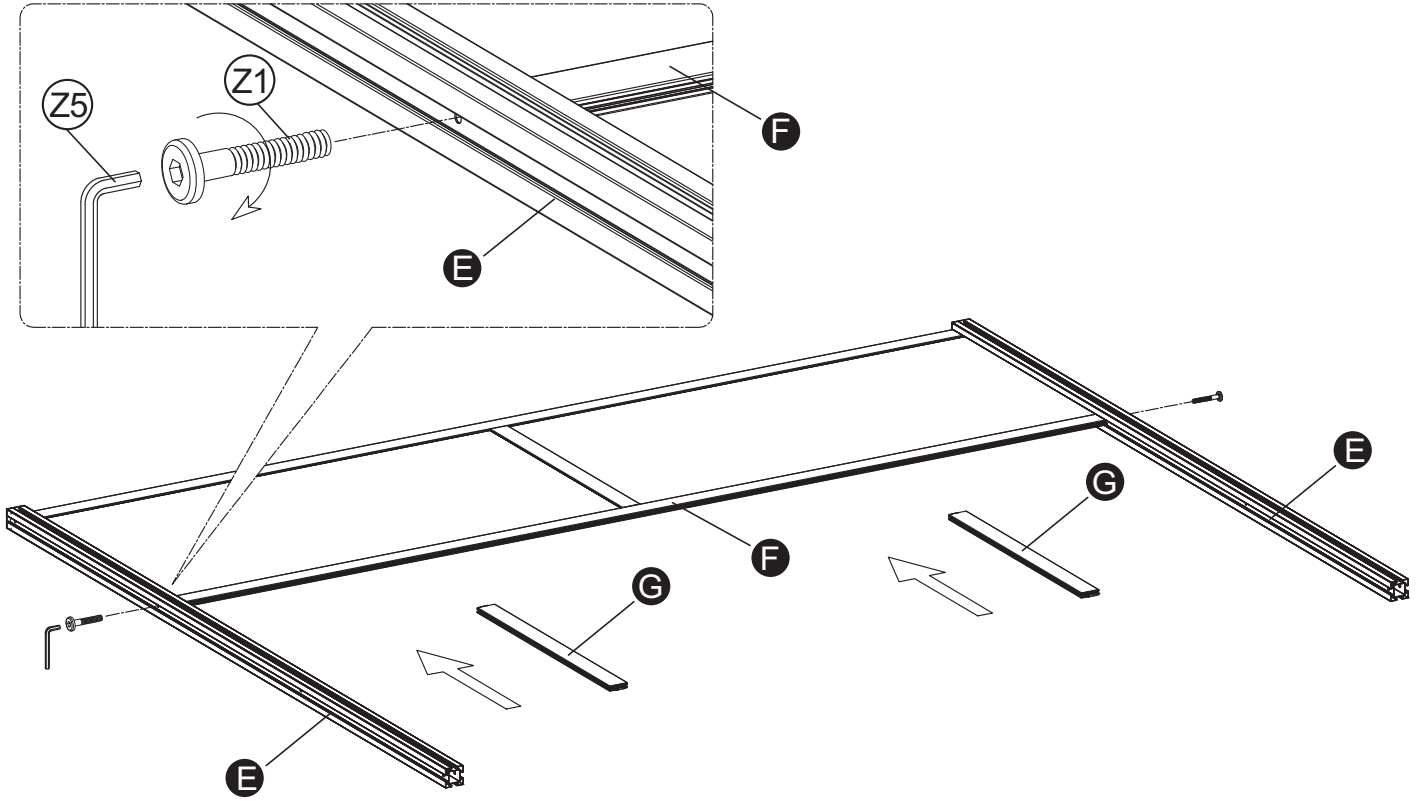

Z1. Bolt M6*60 mm
- 2pcs

Z5. Allen Key
- 1pc

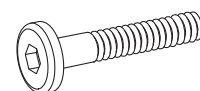

Note: Do not tighten screws until all screws have been started.

Step 4

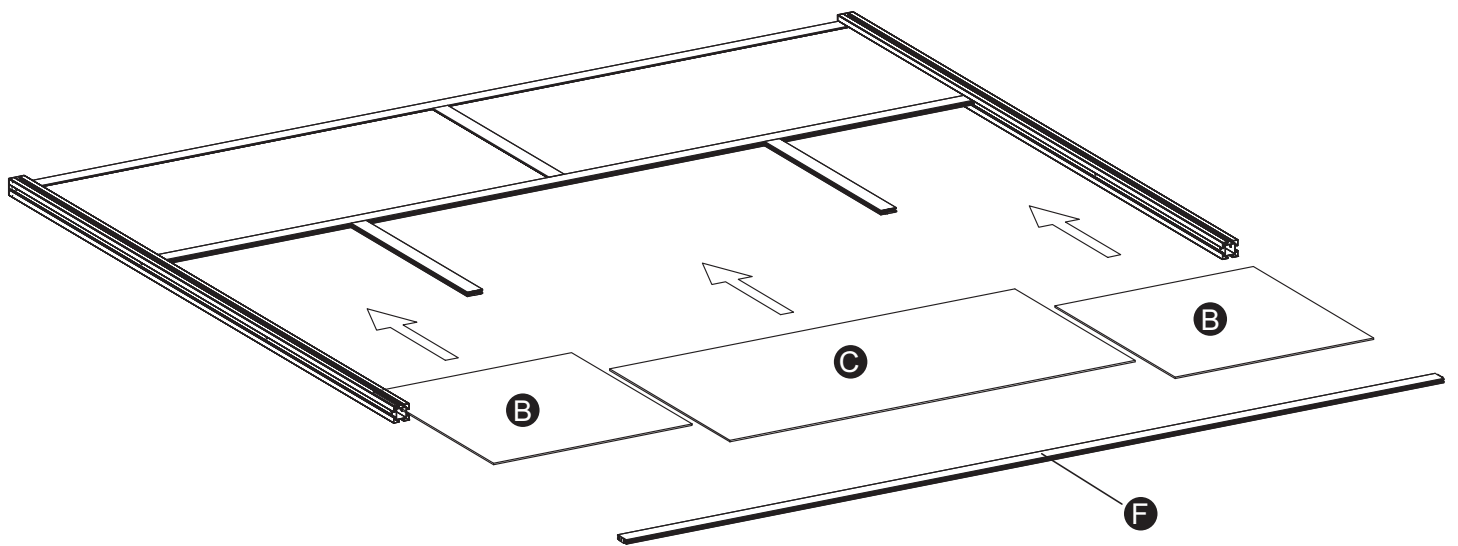

Note: Do not tighten screws until all screws have been started.

Step 5

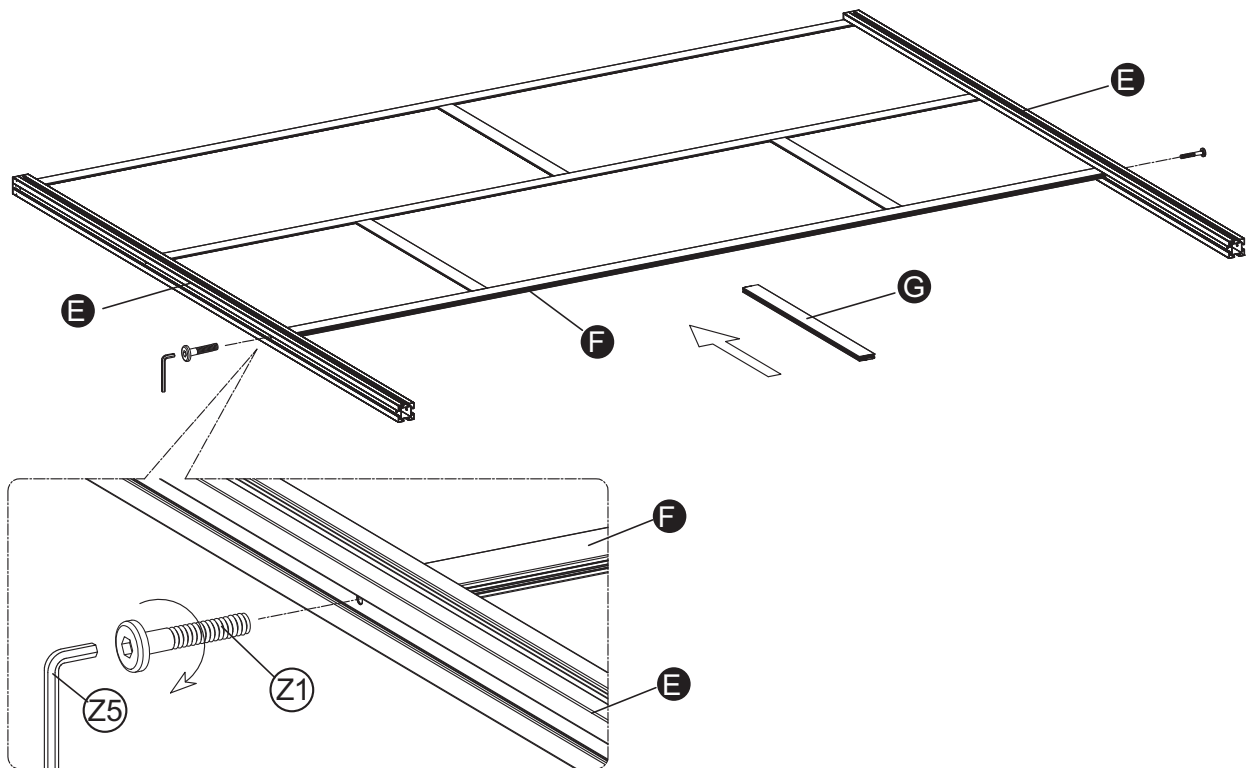

Z1. Bolt M6*60mm
- 2pcs

Z5. Allen Key
- 1pc

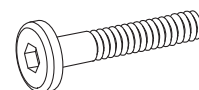

Note: Do not tighten screws until all screws have been started.

Step 6

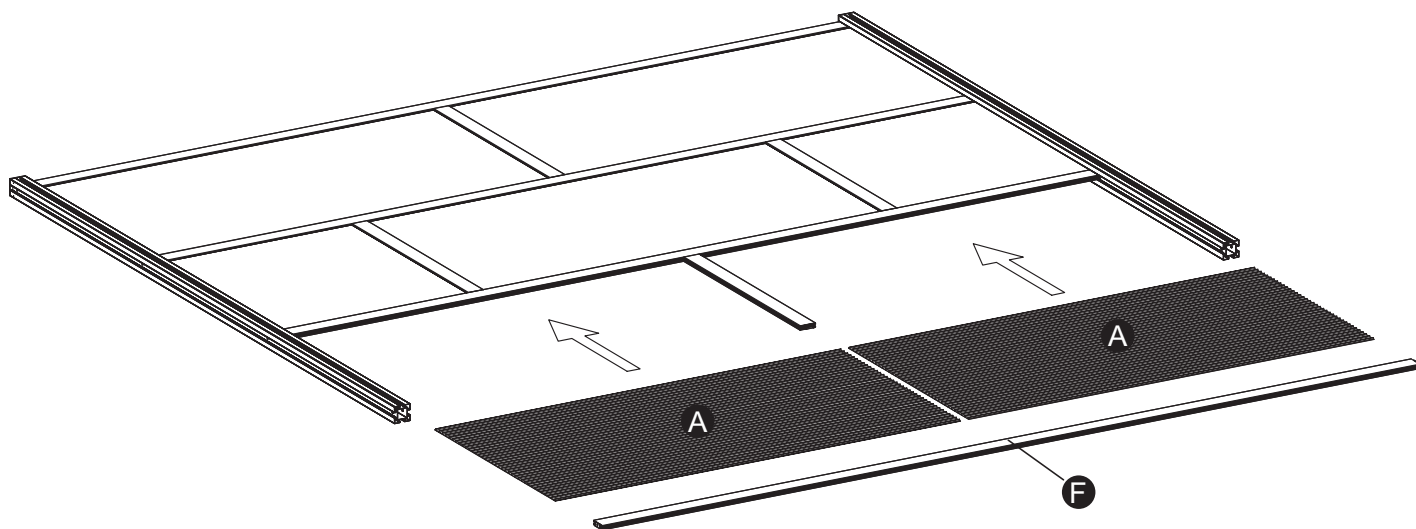

Note: Do not tighten screws until all screws have been started.

Step 7

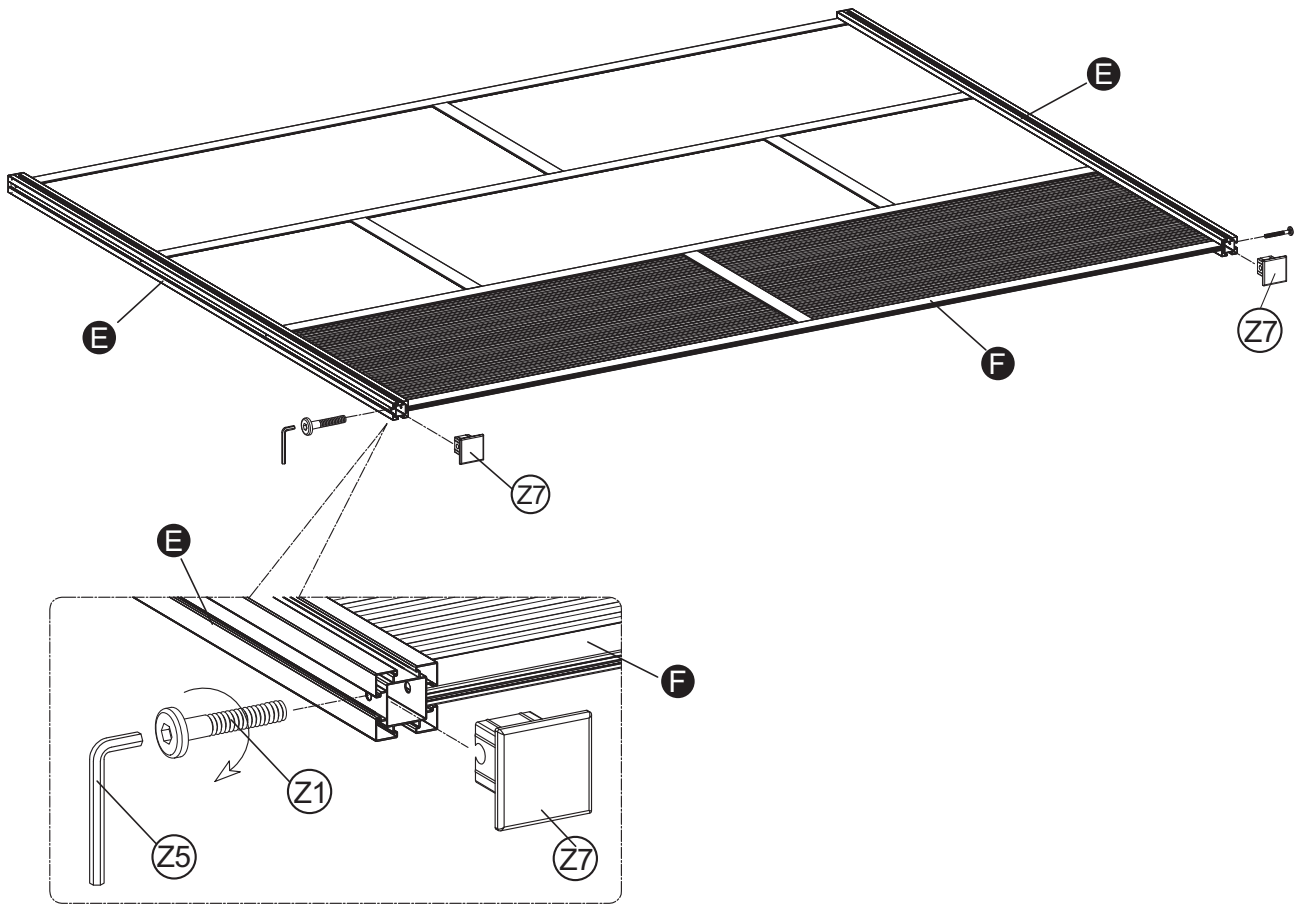

Z1. Bolt M6*60mm -2pcs

Z5. Allen Key -1pc

Z7. Top Cap -2pcs

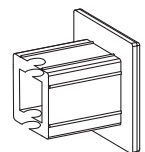
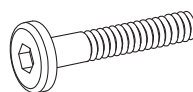

Note: Do not tighten screws until all screws have been started.

Step 8

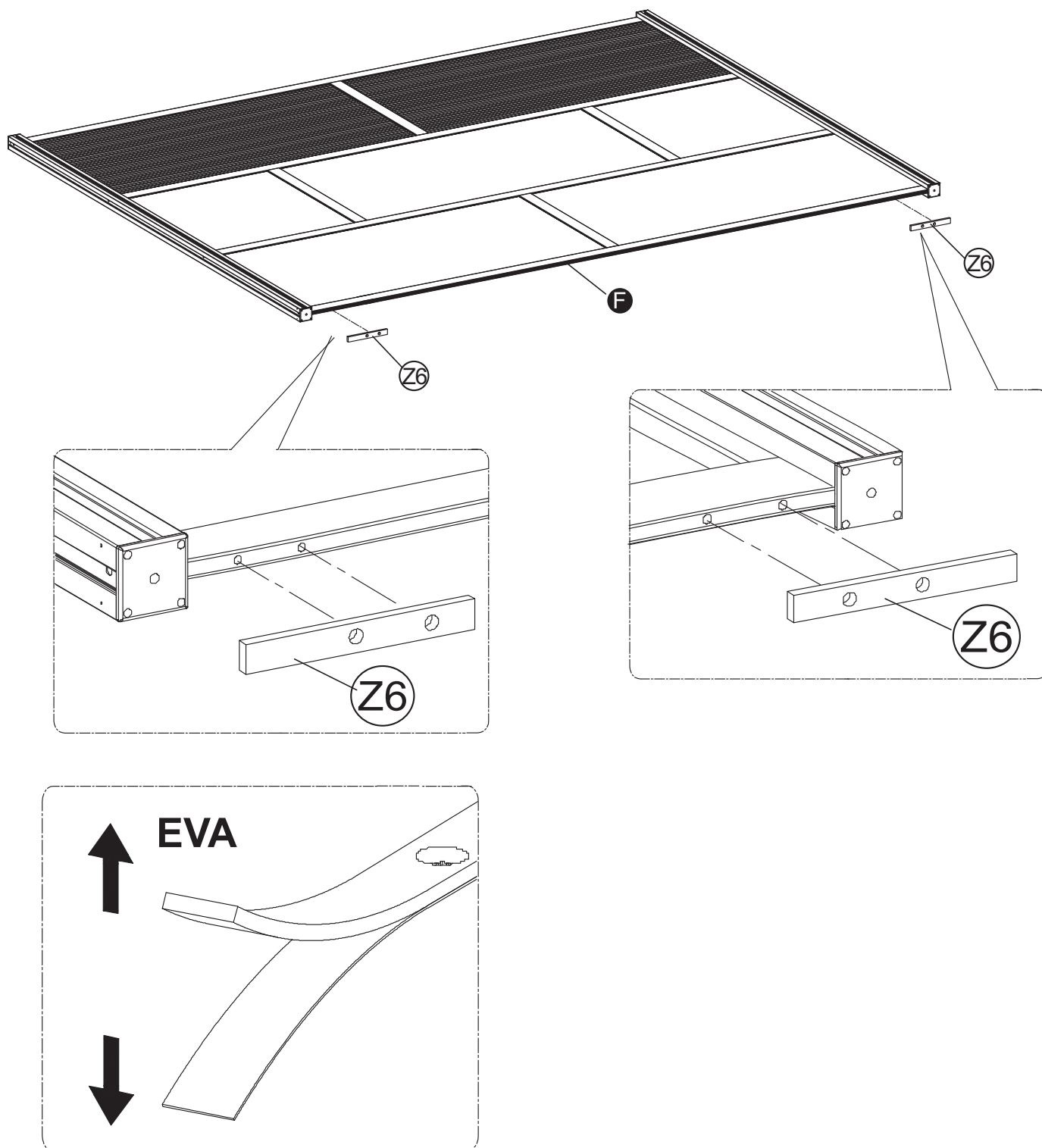

Z6. EVA 100 mm -2pcs

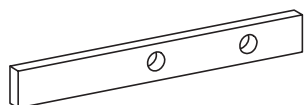

Note: Do not tighten screws until all screws have been started.

Step 9

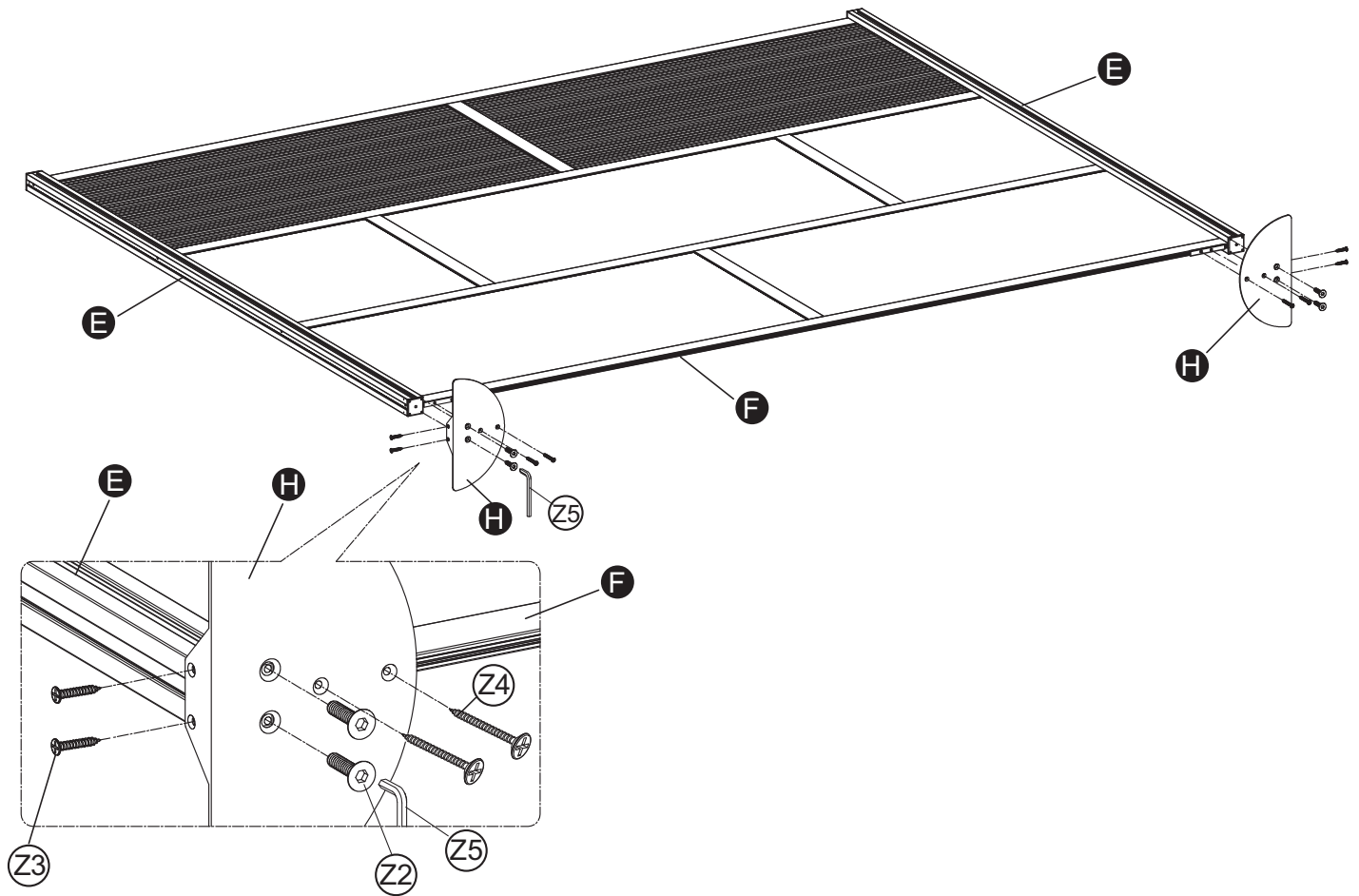

**Z2. Bolt M6*15mm
-4pcs**

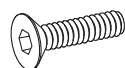

**Z3. Screws 4*12mm
-4pcs**



**Z4. Screws 4*38mm
-4pcs**

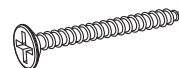

**Z5. Allen Key
- 1pc**



Note: Do not tighten screws until all screws have been started.