

Models 5000L, 5000LE, 5000R, 5000RE Serenity Series

Parts Listing

A
Chair
1 Unit

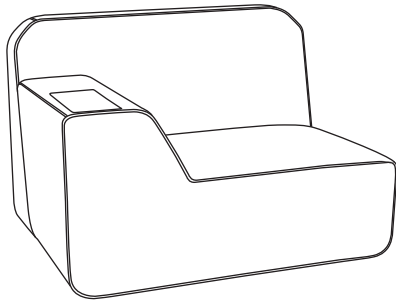

B
Legs
4 Units

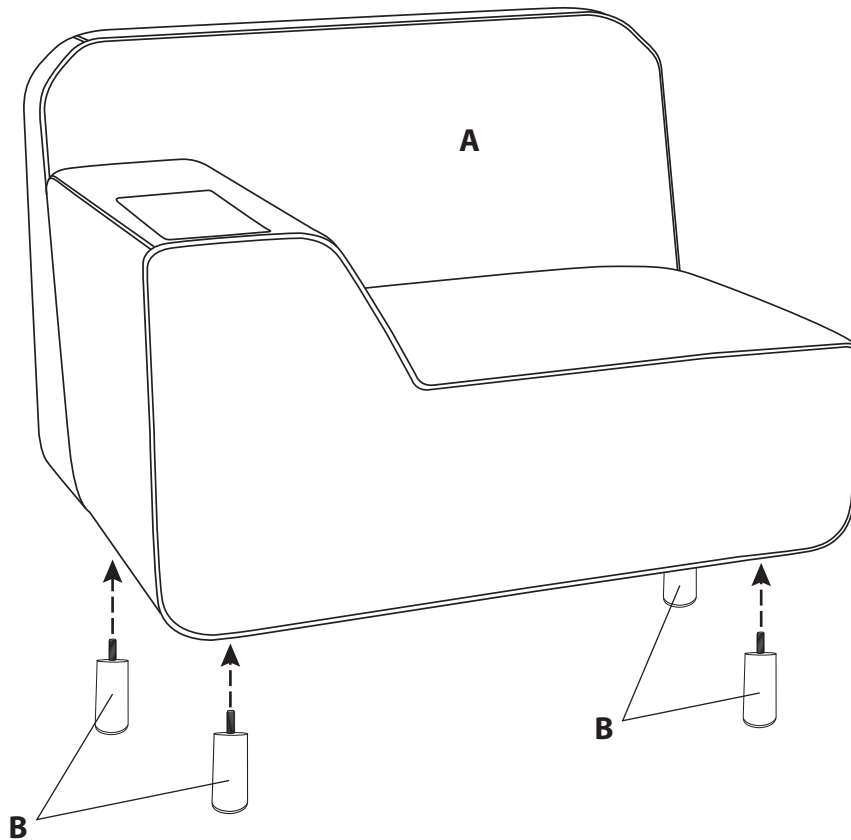

Assembly Instructions



No Tools Required

Models 5000LE & 5000RE

Do This Before Step 1:

Carefully lay Chair (A) onto its back and pull open corner of lining attached with velcro on bottom of Chair (A). Pull out electrical cord and reattach velcro. Plug-in electrical cord or stash cord away in pocket after Legs (B) are attached (see Step 1).

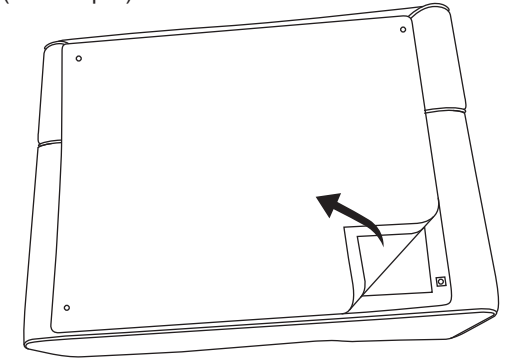

Step 1: Attach the Legs (B) to the Chair (A) by carefully laying the Chair (A) onto its back and screwing the Legs (B) into the corresponding holes in each corner of the bottom of the chair frame and tighten by hand.

Step 2: Return Chair (A) to upright position.

WEIGHT CAPACITY: 500 lbs.

Assembly Notes:

Hand tighten legs only.

CAUTION:

1. Do not use this chair as a step ladder.
2. Check for loose legs and tighten them every 6 months.

ofm
Furniture For The Real Office™

161 Tradition Trail • Holly Springs, NC, 27540
800-520-7471 (voice) • 919-362-4765 (fax)
919-303-6389 (voice) • www.ofminc.com
support@ofminc.com