



Leaders in Reception Seating

Lesro Industries, Inc.
1 Griffin Road South
Bloomfield, CT
06002

Phone
860.243.3226
Fax
860.243.5392
www.lesro.com

Assembly Instructions

For Amherst, Ashford, Belmont, Brewster, Chelsea, Franklin,
Hartford, Lenox, Madison, Savoy, Somerset and Weston Series

Tools required: 1/2" ratchet

Note: These instructions are intended for various models and configurations. Your product may not look exactly as those shown in the diagrams.

Important: The assembly process requires that some hardware be kept loose until later in the sequence. Follow these instructions closely to ensure correct assembly.

Recommendation: Retighten all screws on a seasonal basis to ensure your product remains strong and stable for many years of use.

Weight Capacity: These tables are not intended for use as seats.

Parts List

Tabletop
Legs, 4 pcs.

Hardware Pack

Hex Screws, 4 pcs.
Washers, 4 pcs.

End, Corner & Coffee Tables

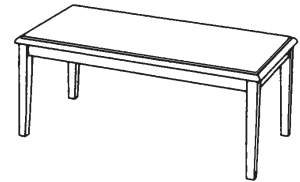
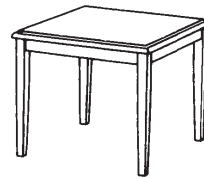
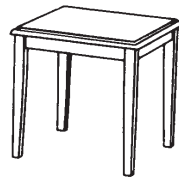

1. Unpack and identify all parts.
2. Place the tabletop upside down on a soft, clean surface to prevent scratches.
3. Attach each leg by inserting a screw with washer through the frame into pre-drilled hole in leg, as shown in the figure.
4. Before tightening screws, be sure each leg is aligned squarely with the frame opening and is pressed firmly against the tabletop
5. Tighten all leg screws firmly using care not to strip.
6. Your product is now assembled and ready to use.

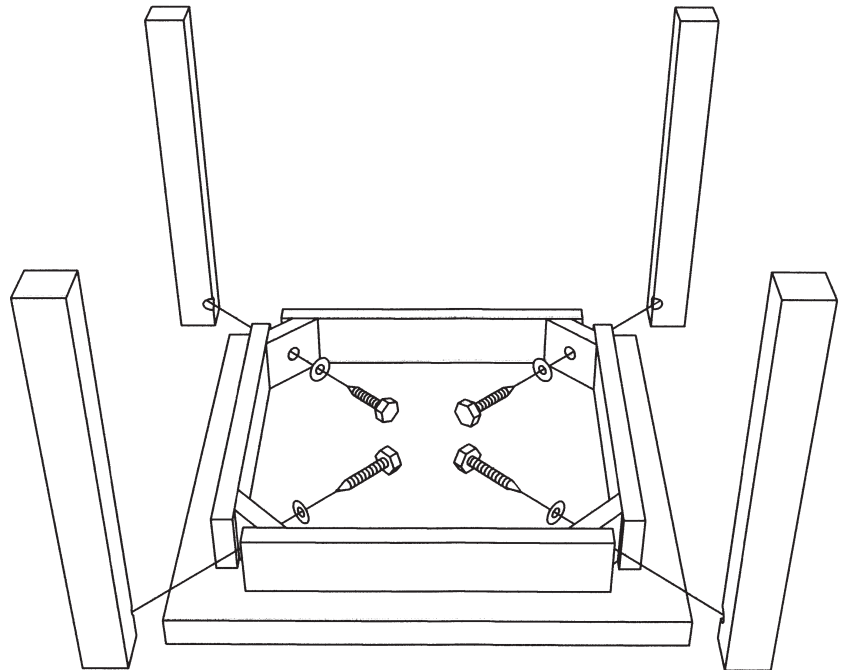

Thank you for purchasing a Lesro product.

Need assistance with assembly? Call Lesro customer service 1-800-275-7545.

Visit us on-line at www.lesro.com