



# 5500MMP

## POLYESTER VERTICAL MESH BACK PROFESSIONAL MANAGER'S CHAIR

### OPERATING INSTRUCTIONS



### FEATURES

#### • PNEUMATIC SEAT HEIGHT ADJUSTMENT

To raise seat remove pressure from seat and lift lever (1) up. To lower seat height sit on chair and lift lever (1) up.

**NOTE:** It is normal for chair to slightly lower under body weight.

#### • 2-TO-1 SYNCHRO TILT ADJUSTMENT

For individual comfort, this chair has been equipped with an adjustment that will allow the user to change the tension of the tilting feature.

Turn knob (2) clockwise to increase tension and counter-clockwise to decrease or ease the tension. To lock return chair to the upright position, push lever (1) in. To unlock pull lever (1) out.

**NOTE:** Be careful not to loosen back tilt adjustment knob completely.

#### • ARM HEIGHT ADJUSTMENT

To adjust arm height, push button (3) in to allow the arms to move up or down freely. Release the button (3) once the desired height is reached.

### WARNING

1. Use this product only one person at a time.
2. Do not use this chair unless all bolts screws and knobs are securely tightened.
3. Check that all bolts screws and knobs are tight every three months or as needed.
4. Do not overturn back tilt knob when decreasing tension.
5. Dispose of packing material properly. Do not use plastic cover as head covering. It may cause suffocation.
6. Do not use chair as a stepladder.
7. Use this chair for its intended purpose only.
8. Use mild detergent only for cleaning.

### LIMITED WARRANTY

NBF® Signature Series chairs are warranted from the date of purchase against failure due to material and workmanship as follows:

- Lifetime on component parts including Control mechanisms, pneumatic cylinders, wood, plastic parts, base and casters.
- 3 Years on upholstery fabric and foam against wear and deterioration.

To make a warranty claim, contact Parts Department. Provide model number, proof of purchase, description of the problem and obtain return authorization. At it's option NBF will:

(a) Supply compatible components of current manufacture.

(b) Repair the customer's component. The customer must prepay freight on any components returned to the factory. Return freight on components still in warranty will be paid by NBF.

*\*All warranties are limited to the original purchaser for normal commercial usage defined as a standard forty hour work week by persons weighing 250 lbs. or less. This warranty will not cover labor, freight or damage from misuse, abuse, negligence, alteration, accident, vandalism, rusting, acts of nature or any other event beyond the control of NBF. The warranty does not cover cosmetic damage that may result from normal use. Liability for incidental or consequential damages is excluded. The user assumes all risk of injury resulting from use of this product. When usage is more than 40 hours per week, a two year warranty on all parts applies. Fabric and foam is warranted for one year. This warranty gives you specific legal rights, and you may also have other rights which vary from state to state.*

Our quality standards are among the highest in the industry. Sometimes, no matter how hard we try, there are times when parts are damaged or missing. Our Parts Department will do everything possible to promptly remedy the problem. Contact our factory by Fax 1-909-930-5629, or toll free parts number 1-800-950-7262, Monday through Friday 8:00 a.m. - 5:00 p.m. Pacific Time.

# 5500MMP

## POLYESTER VERTICAL MESH BACK PROFESSIONAL MANAGER'S CHAIR

### ASSEMBLY INSTRUCTIONS

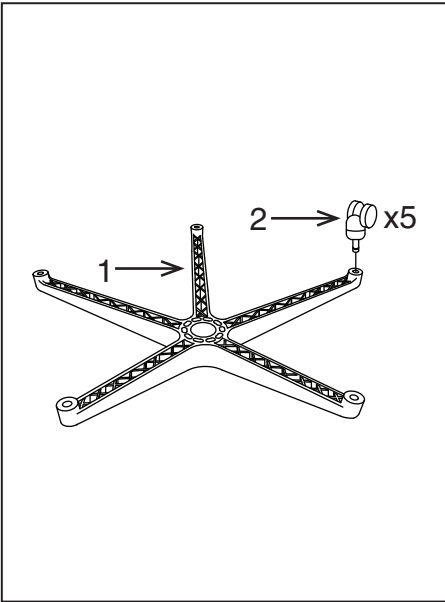
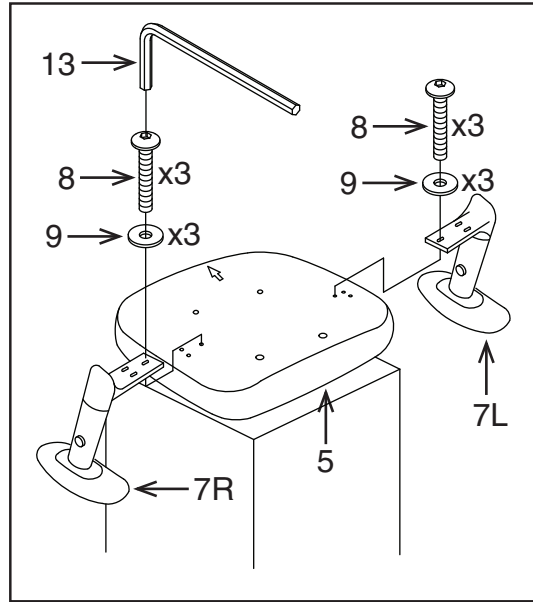
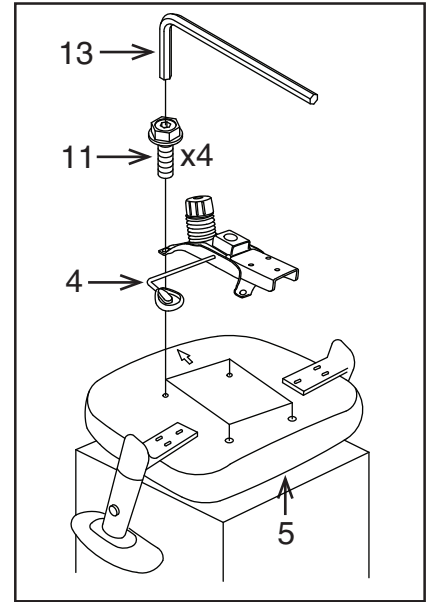
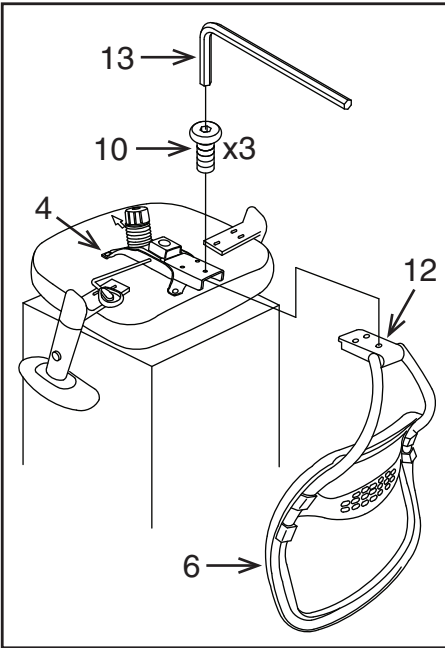
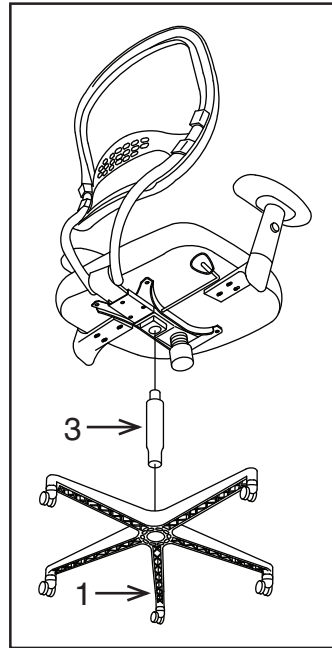
**STEP 1**

**STEP 2**

**STEP 3**

**STEP 4**

**STEP 5**

PART	QTY
1. Base	1
2. Casters	5
3. Pneumatic Cylinder	1
4. Seat Plate	1
5. Seat Cushion	1
6. Back Cushion	1
7. Arms (7L & 7R)	2
8. Arm Screws	6
9. Flat Washers	6
10. Back Support Screws	3
11. Seat Plate Screws	4
12. Back Support (pre-installed)	1
13. Allen Wrench	1

Remove all parts from carton, separate by part numbers indicated on parts list, and verify part quantities.

**STEP 1** Insert five Casters (2) into Base (1), push hard until you feel or hear the Caster (2) snap into place.

**STEP 2** Align the holes in the Arms (7L & 7R) with the holes in the Seat Cushion (5), attach Arms (7L & 7R) to Seat Cushion (5) using three Arm Screws (8) and three Flat Washers (9) for each Arm. **FULLY TIGHTEN ALL ARM SCREWS (8) USING ALLEN WRENCH (13).**

**STEP 3** Attach Seat Plate (4) to Seat Cushion (5) with the arrow towards the front of the chair, secure using four Seat Plate Screws (11), **FULLY TIGHTEN ALL SEAT PLATE SCREWS (11) USING ALLEN WRENCH (13).**

**STEP 4** Attach Back Support (12) to rear of Seat Plate (4) using three Back Support Screws (10).

**FULLY TIGHTEN ALL BACK SUPPORT SCREWS (10) USING ALLEN WRENCH (13).**

**STEP 5** Insert Pneumatic Cylinder (3) into Base (1), Place assembled seat on top of Pneumatic Cylinder (3) and apply downward pressure.

**ATTENTION: MAKE SURE ALL SCREWS ARE FULLY TIGHTENED BEFORE USING CHAIR.**