











**Congratulations on the purchase of your new *OFFICIENT* chair!**

**PARTS:** REMOVE ALL THE PARTS FROM THE CARTON AND VERIFY PART QUANTITIES AS INDICATED IN THIS PARTS LIST.  
PLEASE READ ALL INSTRUCTIONS BEFORE ASSEMBLY. YOU WILL NEED A PHILLIPS-HEAD SCREWDRIVER.

<p><b>A</b></p>  <p>CASTER - QTY: 5</p>	<p><b>B</b></p>  <p>22" BASE - QTY: 1</p>	<p><b>C</b></p>  <p>GAS LIFT - QTY: 1</p>	<p><b>D</b></p>  <p>TELESCOPIC BELLOWS QTY: 1</p>	<p><b>E</b></p>  <p>CHAIR SEAT - QTY: 1</p>	<p><b>F</b></p>  <p>MECHANISM - QTY: 1</p>	<p><b>G</b></p>  <p>SPRING WASHER - QTY: 1</p>
<p><b>H</b></p>  <p>1/4" x 3/4" SCREW QTY: 4</p>	<p><b>I</b></p>  <p>SEAT BACK &amp; BAR: QTY: 1</p>	<p><b>J</b></p>  <p>BACK DEPTH ADJUSTMENT SCREW QTY: 1</p>	<p><b>K</b></p>  <p>FLAT WASHER - QTY: 1</p>	<p><b>ATTENTION:</b> DURING ASSEMBLY, ONLY HAND TIGHTEN THE SCREWS UNTIL ALL THE SCREWS ARE IN PLACE. THEN, MAKE SURE ALL THE SCREWS ARE FULLY TIGHTENED BEFORE USING THE CHAIR.</p>		

**INSTRUCTIONS**

**STEP ONE** Insert the **CASTERS** **A** into the **BASE** **B**.

**STEP TWO** Insert the **GAS LIFT** **C** into the **BASE**.

**STEP THREE** Cover the **GAS LIFT** with the 3-piece **TELESCOPIC BELLOWS** **D**.

**STEP FOUR** Place the **CHAIR SEAT** **E** on a level, non-abrasive surface and align the pre-drilled holes in **MECHANISM** with the holes in the **CHAIR SEAT**.

**STEP FIVE** Insert the four **1/4" x 3/4" SCREWS** **H** through the holes in the **SEAT MECHANISM** into the holes in the **CHAIR SEAT**. Tighten with a screwdriver.

**IF YOU ARE ASSEMBLING A MODEL WITH OPTIONAL ADJUSTABLE ARMS, PLEASE PROCEED TO THE NEXT PAGE FOR ASSEMBLY INSTRUCTIONS.**

**STEP SIX** Carefully place the **CHAIR SEAT** with the attached **SEAT MECHANISM** onto the **GAS LIFT** aligning the hole in the **SEAT MECHANISM** with the **GAS LIFT**.

Press down on the **CHAIR SEAT** to secure onto the **BASE**.

**STEP SEVEN** Slide the **SEAT BAR** **I** (the end with the pre-drilled hole) under the **CHAIR SEAT** and into the slot in the **SEAT MECHANISM**.

**STEP EIGHT** Place the washers **G** and **K** on the threaded end of the **BACK DEPTH ADJUSTMENT SCREW** **J** and insert into the slot in the **SEAT MECHANISM** and into the pre-drilled hole in the **SEAT BACK BAR**. Hand tighten to hold in place.

**STEP NINE** Carefully sit on the chair to make sure the **GAS LIFT** is properly inserted into the **BASE**.

**STEP TEN** Operate the **GAS LIFT LEVER** on the **MECHANISM** to be sure the unit is working properly.

**STEP ELEVEN** Re-adjust the **BACK DEPTH ADJUSTMENT SCREW** accordingly for personal comfort.

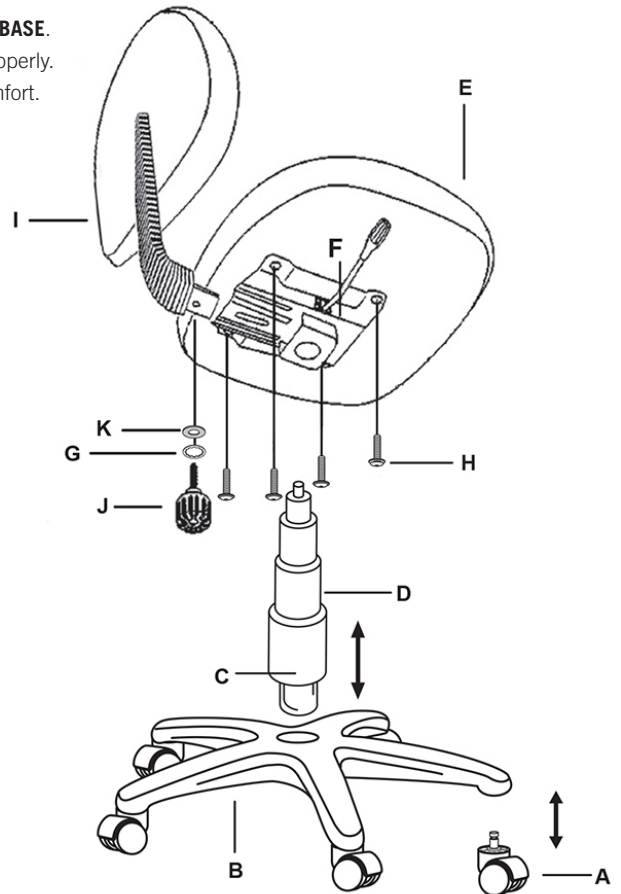

**CAUTION:**  
DO NOT USE THIS CHAIR AS A  
STEP LADDER. PERIODICALLY  
CHECK FOR LOOSE SCREWS  
AND TIGHTEN THEM .