

3000 Series Leg Installation & Ganging Instructions

Parts Listing

Base Chair/Cushion
included with all models

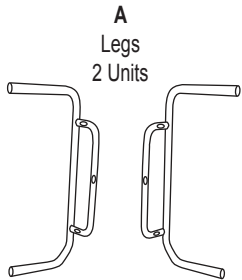

B
8x50mm Screw
6 Units

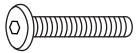

C
Allen Wrench
1 Unit



D
Ganging Brackets
2 Sets

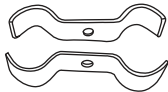

E
Ganging Bracket Screw
2 Units



F
Ganging Bracket Nut
2 Units

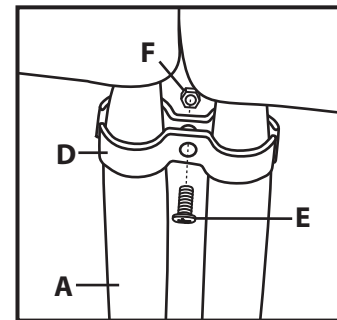
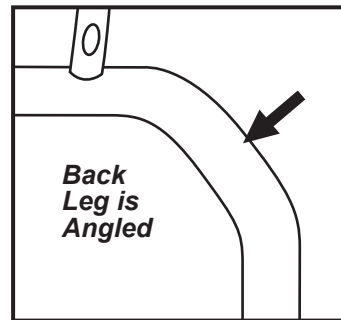
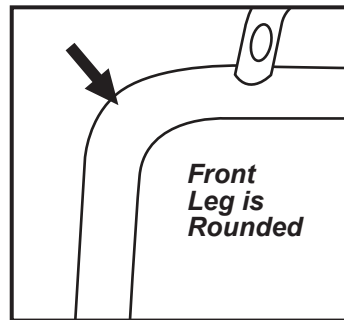
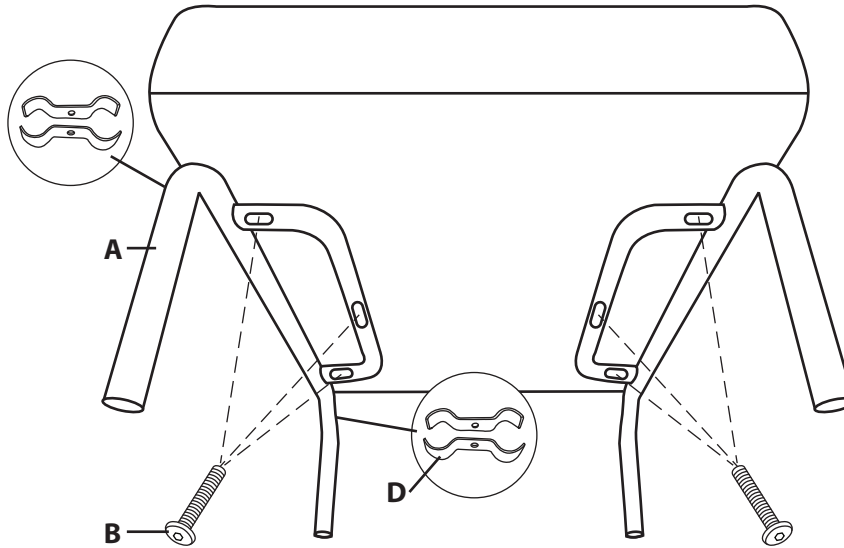

Assembly Notes:

During assembly, hand tighten screws. Only when all screws are in place, you may then tighten all screws completely.

CAUTION:

1. Do not use this product as a step ladder.
2. Check for loose screws and tighten them every 6 months.

Assembly Instructions



Tools Needed: Allen Wrench (provided), Screw Driver
Note: *The front leg is rounded.*
The back leg is angled.

Step 1: Remove pre-inserted Screws (B) from the bottom of the Chair/Cushion. Attach Legs (A) by aligning the holes in the Legs (A) with the corresponding holes in the Cushion. **Note: Make sure angled leg is to the back of the Cushion.**

Step 2: Attach by inserting 8x50mm Screws (B) through Legs (A) and into the Cushion using an Allen Wrench (C).

Step 3: If applicable, attach Ganging Bracket (D) to Legs (A) using Ganging Bracket Screw (E) and Ganging Bracket Nut (F). Tighten using Screw Driver.

ofm
Furniture For The Real Office™

161 Tradition Trail, Holly Springs, NC, 27540
www.ofmfurniture.com
800-520-7471 (voice) 919-362-4765 (fax)
919-303-6389 (voice) support@ofminc.com