

WARRANTY INFORMATION

SERVICE INSTRUCTIONS

1. DO NOT attempt to repair or adjust any electrical or mechanical functions on this unit. Doing so will void the warranty.
2. If you have any questions regarding this unit's operation or believe any repair is necessary, please write to our Consumer Service Department.
3. If you need to exchange the unit, please return it in its original carton, with a sales receipt, to the store where you purchased it. If you are returning the unit more than 30 days after the date of purchase, please see the enclosed warranty.
4. If you have any other questions or comments, see our correspondence below:

JCS/THG, LLC
13120 JURUPA AVENUE
FONTANA, CA 92337

For your own records, staple or attach your sales receipt to this manual. Also, please take a moment to write the store name/location and date purchase below.

STORE NAME: _____

LOCATION: _____

DATE PURCHASED: _____

(STAPLE RECEIPT HERE)

WARRANTY INFORMATION

ONE (1) YEAR LIMITED WARRANTY

SAVE THIS WARRANTY INFORMATION

- A. This Warranty applies only to the original purchaser of this product.
- B. This Warranty applies ONLY to repair or replacement of any supplied or manufactured parts of this product that, upon inspection by JCS/THG, LLC authorized personnel, is shown to have failed in normal use due to defects in material or workmanship. JCS/THG, LLC will determine whether to repair or replace the unit. This Warranty does not apply to installation expenses.
- C. Operating this unit under conditions other than those recommended or at voltages other than the voltage indicated on the unit, or attempting to service or modify the unit, will render this WARRANTY VOID.
- D. Unless otherwise proscribed by law JCS/THG, LLC shall not be liable for any personal injury, property or any incidental or consequential damage of any kind resulting from malfunctions, defects, misuse, improper installation or alteration of this product.**
- E. All parts of this product excluding filters, which are covered under separate warranty, are guaranteed for a period of 1 year as follows:
1. Within the first 30 days from date of purchase, the store from which you purchased your product should replace this product if it is defective in material or workmanship (provided the store has in-stock replacement.) If you intend to assert any claim in connection with the product, please follow the instructions in paragraph F.
 2. Within the first twelve months from date of purchase, JCS/THG, LLC will repair or replace the product if it is defective in material or workmanship, subject to the conditions in paragraph G.
- F. If you have any other problem or claim in connection with this product, please write to our Consumer Service Department.
- G. **IMPORTANT RETURN INSTRUCTIONS.** Your Warranty depends on your following these instructions if you are returning the unit to JCS/THG, LLC:
1. Carefully pack the item in its original carton or other suitable box to avoid damage in shipping.
 2. Before packing your unit for return, be sure to enclose:
 - a) Your name, full address with zip code and telephone number,
 - b) A dated sales receipt or PROOF OF PURCHASE,
 - c) Your \$6.00 check for return shipping and handling, and
 - d) The model number of the unit and the problem you are having. (Enclose in an envelope and tape directly to the unit before the box is sealed.)
 3. JCS/THG, LLC recommends you ship the package U.P.S. ground service for tracking purposes.
 4. All shipping charges must be prepaid by you.
 5. Mark the outside of your package:

JCS/THG, LLC
13120 JURUPA AVENUE
FONTANA, CA 92337

SHIPPING AND HANDLING CHARGES: \$6.00 (USD)

This Warranty gives you specific legal rights, and you may have other rights which vary from state to state. The provisions of this Warranty are in addition to, and not a modification of, or subtraction from, the statutory warranties and other rights and remedies contained in any applicable legislation. To the extent that any provision of this Warranty is inconsistent with any applicable law, such provision shall be deemed voided or amended, as necessary, to comply with such law.

9100040002323

AOR11805EM2

Printed in China



Owner's Guide

AOR118



Air Purifier

PLEASE READ AND SAVE THESE IMPORTANT INSTRUCTIONS

© 2005 JCS/THG, LLC

The ARM & HAMMER name, logo and associated marks are trademarks of Church & Dwight Co., Inc. and are under license by JCS/THG, LLC.

PLEASE READ AND SAVE THESE IMPORTANT SAFETY INSTRUCTIONS

When using electrical appliances, basic safety precautions should always be followed to reduce the risk of fire, electric shock, and injury to persons, including the following:

1. Read all instructions before using the appliance.
2. To avoid fire or shock hazard, plug the appliance directly into a 120V AC electrical outlet.
3. If the filter is covered by a bag when shipped: Remove plastic bag before use.
4. Keep the cord out of heavy traffic areas. To avoid fire hazard, NEVER put the cord under rugs, near heat registers, radiators, stoves, or heaters.
5. To protect against electrical hazards, DO NOT immerse in water or other liquids. Do not use near water.
6. Close supervision is necessary when any appliance is used by or near children, or disabled persons.
7. Always unplug the air purifier before moving it, changing the filters, cleaning, or whenever the air purifier is not in use. Be sure to pull by the plug and not the cord.
8. NEVER drop or insert any object into any openings.
9. DO NOT operate any appliance with a damaged cord or plug, if motor fan fails to rotate, after the appliance malfunctions, or if it has been dropped or damaged in any manner. Return appliance to manufacturer for examination, electrical or mechanical adjustment, or repair.
10. Use appliance only for intended household use as described in this manual. Any other use not recommended by the manufacturer may cause fire, electric shock, or injury to persons. The use of attachments not recommended by the manufacturer may cause hazards.
11. DO NOT use outdoors.

12. Never block the air openings, or place on soft surface, such as bed or sofa, as this could cause the unit to tip over thus blocking the air intake opening.
13. Keep unit away from heated surfaces and open flames.
14. DO NOT attempt to repair or adjust any electrical or mechanical functions on this unit. Doing so will void the warranty. The inside of the unit contains no user serviceable parts. All servicing should be performed by qualified personnel only.
15. WARNING: To reduce the risk of fire or electrical shock, DO NOT use this air purifier with any solid-state speed control device.
16. DO NOT place anything on top of the unit.

PLEASE READ AND SAVE THESE IMPORTANT SAFETY INSTRUCTIONS

Congratulations on your purchase of an air purifier. Your air purifier has an attractive stylish design. Its versatility and quiet operation make this unit perfect for both the home and the office.

CORD AND PLUG INSTALLATION SAFETY INSTRUCTIONS

The length of the cord used on this appliance was selected to reduce the hazards of becoming tangled in or tripping over a longer cord. If a longer cord is necessary, an approved extension cord may be used. The electrical rating of the extension cord must be equal to or greater than the rating of the air purifier. Care must be taken to arrange the extension cord so that it will not drape over the countertop or table-top where it can be pulled on by children or accidentally tripped over.

THIS PRODUCT IS EQUIPPED WITH A POLARIZED PLUG (a plug having one blade wider than the other). This plug will fit into the power outlet only one way. If the plug does not fit fully into the outlet, reverse the plug. If it still does not fit, contact qualified personnel to install the proper outlet.

DO NOT DEFEAT THE SAFETY PURPOSE OF THIS POLARIZED PLUG IN ANY WAY

FEATURES - OPERATIONS

IONIZER

Your air purifier has an independently controlled ionizer, which, when turned on, releases negative ions into outgoing filtered air. Ions are tiny particles that carry a positive or negative charge. These ions exist naturally around us, in the air, water, and ground. Both positive and negative ions are colorless, odorless, and completely harmless. Negative ions help the air purification process by attaching themselves to very small airborne particles in the room.

These particles take on a negative charge and may join with positively charged particles such as dust, pollen, smoke, and pet dander to form larger particles that are then more readily captured by the filter system, or may be attracted to positively charged surfaces throughout the home, like walls or floors. This may occur more frequently when the filter is nearing the end of its functional life expectancy and is able to capture less of the charged particles.

You may also note after extended use, that dust has collected around the grills or front panel. This is from the ionization affect caused by the negative ions exiting from the air outlet. This is additional evidence of the air cleaning effectiveness of negative ions. The dust can be easily removed with a clean, damp cloth or soft brush.

Finally, using your ionizer may result in an occasional popping or cracking sound. This is a normal sound, generally caused by a small build-up of ions that, when discharged, cause the popping or cracking sound.

NOTE: It is important to replace the multi-stage filter at the recommended intervals.

Using the ionizer in conjunction with dirty filters may result in dirty particles exiting the air purifier and being attracted to walls, carpets, furniture, or other household objects. These dirty particles may prove very difficult to remove. Homes with excessive amounts of pet dander, dust, or smoke may decrease the life expectancy of the multi-stage filter system and may interfere with the ionization process. You may want to run the ionizer less often and/or check the condition of the multi-stage filter more frequently in order to reduce particles from being attracted to surfaces throughout your home as mentioned above.

PRE-OPERATING INSTRUCTIONS

1. When removing the air purifier from the packing case, visually check for shipping damage. Please contact your dealer immediately if the unit bears any sign of damage.
2. Keep shipping carton and packing for use in the unlikely event that your unit needs servicing. If this unit is shipped without the original packaging, damage could occur and void the warranty.
3. Your air purifier comes to you ready for use, as the multi-stage filter cartridge has been installed in the unit.

PLEASE FAMILIARIZE YOURSELF WITH THE INSTRUCTIONS THAT FOLLOW BEFORE CONNECTING THE UNIT TO A POWER SOURCE.

OPERATING INSTRUCTIONS

1. Remove your new air purifier from its protective plastic bag.
2. Choose a suitable location, tabletop or shelf ensuring that both the air intake and exit are unobstructed. Remember, air enters the rear of the unit and exits from the front.
3. Turn the Fan Control Switch (F) to provide the desired airflow:
Off (**O**)
Low (**I**) - for continuous operation
High (**II**) - for maximum air cleaning when high levels of air pollution are present

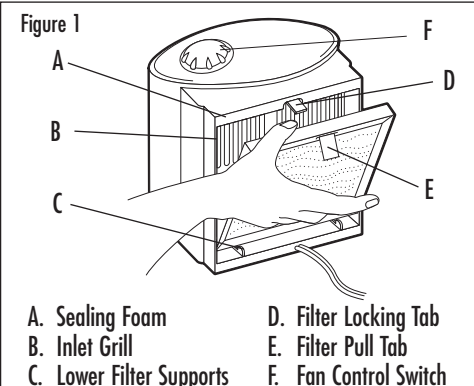

CLEANING INSTRUCTIONS TROUBLESHOOTING

CLEANING INSTRUCTIONS

Turn off and unplug unit before cleaning.

PLASTIC HOUSING – A soft damp cloth and non-abrasive cleaner may be used to remove any excessive dirt or fingerprints. Treated like any other quality appliance, your unit will retain its attractive appearance for many years.

Filter - Do not wash the multi-stage filter cartridge. This is a disposable item (see "Changing The Filter" section).

CHANGING THE FILTER

To keep your air purifier operating at its peak efficiency, the multi-stage filter cartridge should be replaced on a regular basis. While the length of time between filter changes will vary based on the amount of use and the conditions in which the unit is run, it will be approximately every three months. To change the filter, use the following steps.

1. Looking at the back of the unit, notice the unit's Filter Locking Tab (D) and a Filter Pull Tab (E) on the filter. Gently pull up on the Filter Locking Tab (D) while pulling outward on the Filter Pull Tab (E). The filter should pull away from the unit.
2. Discard the used filter; gently wipe the Inlet Grill (B) with a small soft brush or cloth taking care not to damage the foam gasket.
3. Remove the replacement filter from its packaging and its sealed bag. Mark on the "Replacement Filter" sticker the date on which the filter should likely be replaced. This date should be approximately three months from date of installation.
4. Install the filter with the Filter Pull Tab (E) located at the top and facing outward (see Figure 1) and introducing the bottom of the filter into the filter cavity. The filter will be resting against the sealing foam and on the Lower Filter Supports (C).
5. Push Filter into Filter Locking Tab (D). The filter tab should latch on the filter.

REPLACEMENT FILTER (MODEL AOR115PDQ-U) IS AVAILABLE AT YOUR LOCAL RETAILER OR BY CALLING 1-800-5-HOLMES.

TROUBLESHOOTING

Problem	Solution
Unit will not operate	Check to make sure unit is properly plugged in. Check to make sure the unit is on by rotating the power switch to the ON position.
Decreased air flow	Check the filters to see if they are in good condition and if they need to be changed. Check to ensure nothing is blocking air inlet and filtered air outlet.