



National Business Furniture

# Assembly Instructions

## For New Castle, Mason Street, and Ridgewood Series

**Tools required:** Rubber mallet (Standard hammer is not recommended)

**Note:** These instructions are intended for various models and configurations, with and without arms. Your products may not look exactly as those shown in the diagrams.

**Important:** The assembly process requires all interlocking wedge hardware be kept loose until later in the sequence. Once all parts are properly connected, it is then safe to tighten and secure hardware. Follow these instructions closely to ensure your product remains strong and stable for many years of use.

**Weight Capacity:** All chairs in these series have a weight capacity of 300 lbs. per seat, unless otherwise stated.

1. Unpack and identify all parts. **Important: The white label on the bottom of the seat goes in the back.**
2. This chair is held together by use of **interlocking wedge** hardware, as shown in figure 1.
3. Attach the seat cushion to one leg frame by aligning the interlocking wedges and sliding them together simultaneously, as shown in figure 2. **Important: Keep these wedge connections loose for now.**
4. Repeat step 3 to attach the second leg frame to the seat cushion. Keep these connections loose for now as well.
5. Stand the chair upright and slide the back cushion between the leg frames, as shown in figure 3. Use care that the wedges on both sides are properly aligned and connected simultaneously. Do not attempt to insert one side ahead of the other. Keep these wedge connections loose for now.
6. With the chair upright on a level surface, use your hands to apply pressure to the seat and back cushions a little at a time. You should feel the wedges slide together and tighten.
7. With scrap cardboard or other protective material over the fabric, use a rubber mallet (not a standard hammer) to gently tap the seat and back cushions until the interlocking wedges are "locked" together. **Important: Wedges are correctly "locked" when the inner wedge comes into contact with the top flap of the outer wedge, and the bottom edges align, as shown in figure 4. Avoid excessive force or damage to the wedges may occur.**
8. Wedge connections must be visually inspected before use to ensure all are correctly set and locked.
9. Your product is now assembled and ready to use.

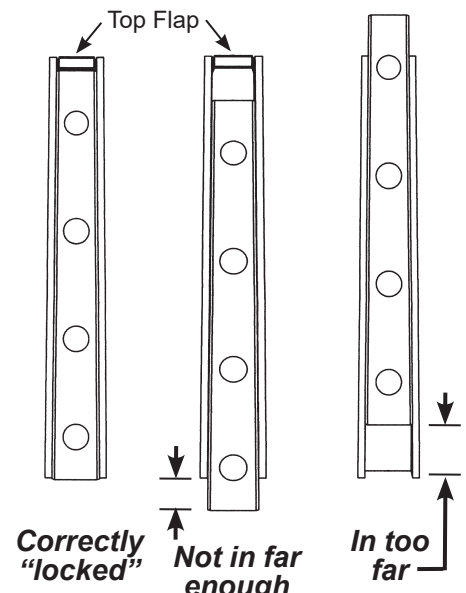
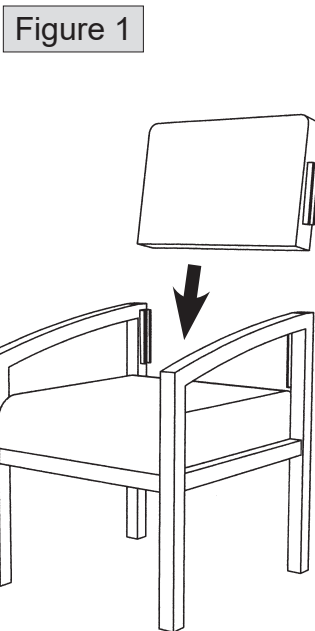
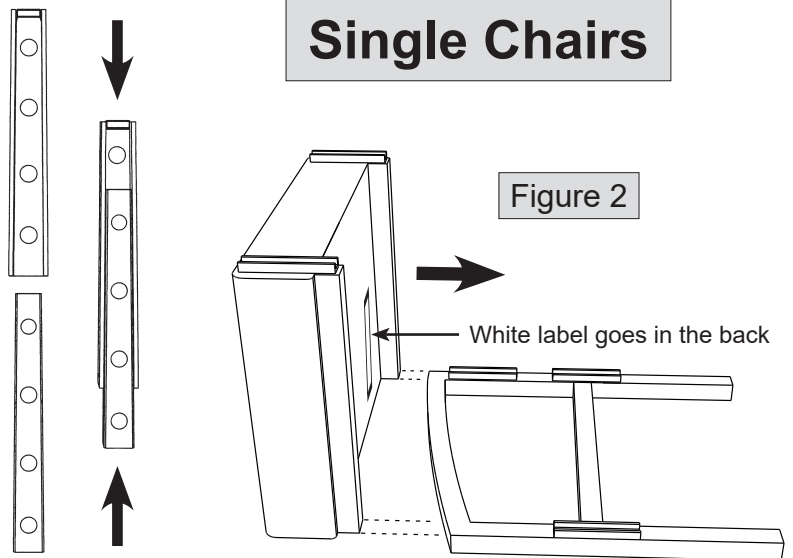

**TROUBLESHOOTING TIP:** If chair does not sit level on the floor, check that all wedges are correctly "locked," as shown in figure 4.

Thank you for purchasing this NBF product!  
Need assistance with parts or assembly? Call 800.275.7545



**National Business  
Furniture**

# Assembly Instructions

## For New Castle, Mason Street, and Ridgewood Series

**Tools required:** Rubber mallet (Standard hammer is not recommended)

**Note:** These instructions are intended for various models and configurations, with and without arms. Your products may not look exactly as those shown in the diagrams.

**Important:** The assembly process requires all interlocking wedge hardware be kept loose until later in the sequence. Once all parts are properly connected, it is then safe to tighten and secure hardware. Follow these instructions closely to ensure your product remains strong and stable for many years of use.

**Weight Capacity:** All chairs in these series have a weight capacity of 300 lbs. per seat, unless otherwise stated.

1. Unpack and identify all parts. Center legs have wedge hardware on both sides. Left and right legs have wedge hardware on one side only. **Important: The white label on the bottom of each seat cushion goes in the back.**
2. These chairs are held together by use of *interlocking wedge* hardware, as shown in figure 1 on opposite side of this sheet.
3. Start with the right leg frame to assemble the first chair and follow steps 3 and 4 on the opposite side of this sheet. **Important: keep all wedge hardware connections loose for now and do not attach back cushions at this time.**
4. Continue attaching seat cushions and leg frames until entire set is assembled, as shown in figure 5. **Again, keep all wedge hardware connections loose.**
5. Once all seat cushions and leg frames have been connected, place entire assembly upright on a level surface.
6. Slide back cushions between the leg frames as shown in figure 6. Use care that the wedges on both sides are properly aligned and connected simultaneously. Do not attempt to insert one side ahead of the other. **Keep these wedge connections loose until all back cushions are in place.**
7. With the assembly upright on a level surface, use your hands to apply pressure to each seat and back cushion a little at a time. You should feel the wedges slide together and tighten.
8. With scrap cardboard or other protective material over the fabric, use a rubber mallet (not a standard hammer) to gently tap the seat and back cushions until the interlocking wedges are "locked" together. Refer to figure 4 on opposite side of this sheet.  
**Important: Wedges are correctly "locked" when the inner wedge comes into contact with the top flap of the outer wedge, and the bottom edges align, as shown in figure 4. Avoid excessive force or damage to the wedges may occur.**
9. Wedge connections must be visually inspected before use to ensure all are correctly set and locked.
10. Your product is now assembled and ready to use.

### Connecting Chairs & Sofas

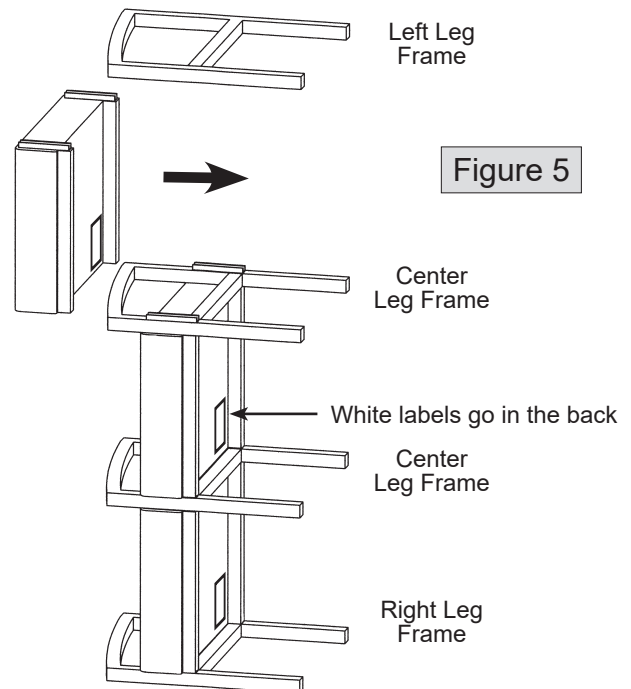

Figure 5

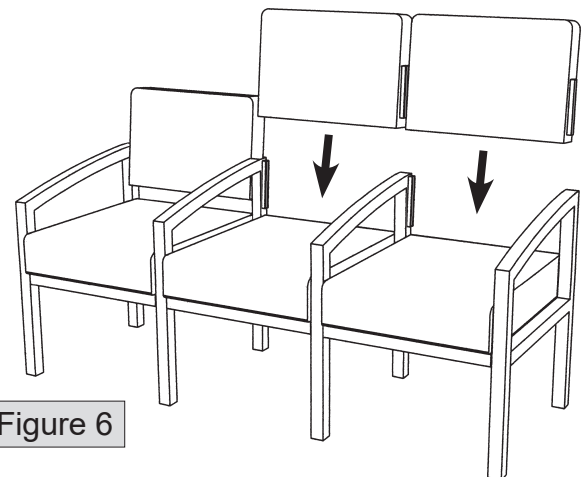

Figure 6

**TROUBLESHOOTING TIP: If chairs do not sit level on the floor, check that all wedges are correctly "locked" as shown in figure 4 on opposite side of this sheet.**

**Thank you for purchasing this NBF product!  
Need assistance with parts or assembly? Call 800.275.7545**