

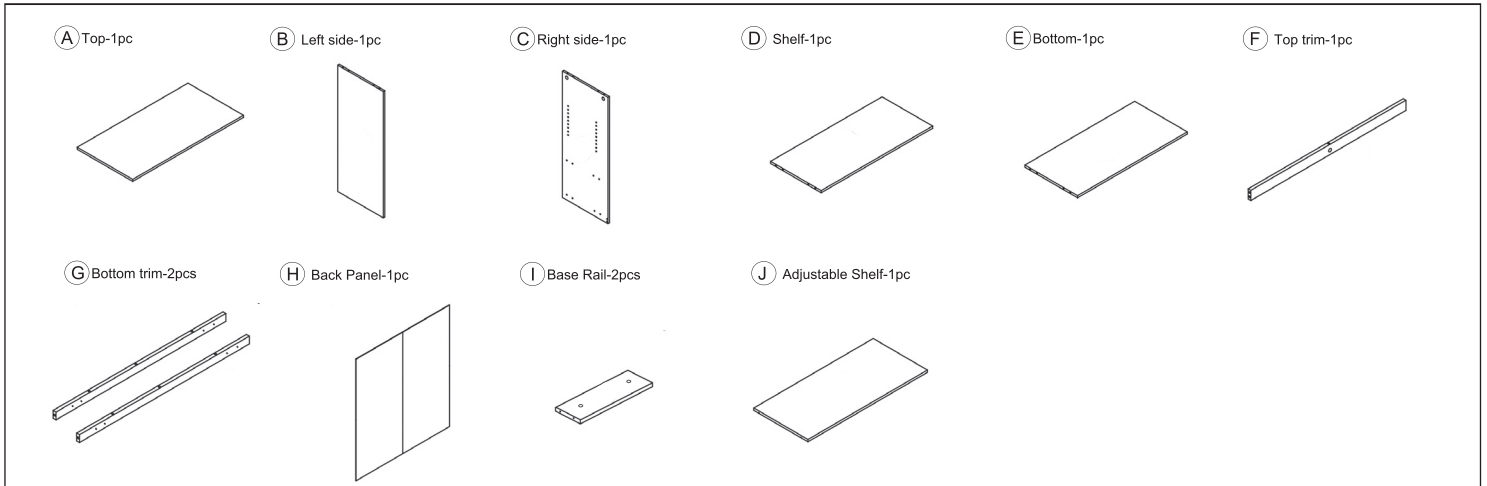

At Work- Bookcase

Assembly Instructions

COMPONENTS



HARDWARE & TOOLS

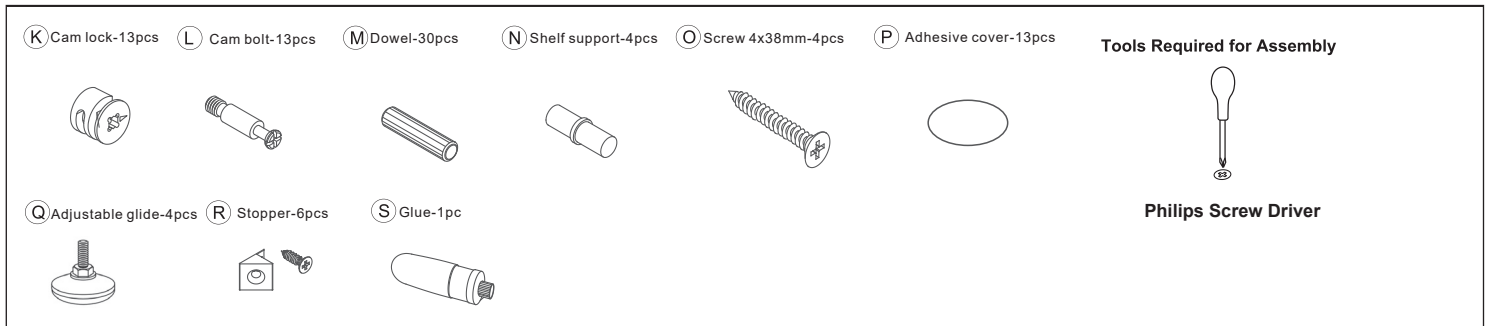

INSTRUCTIONS

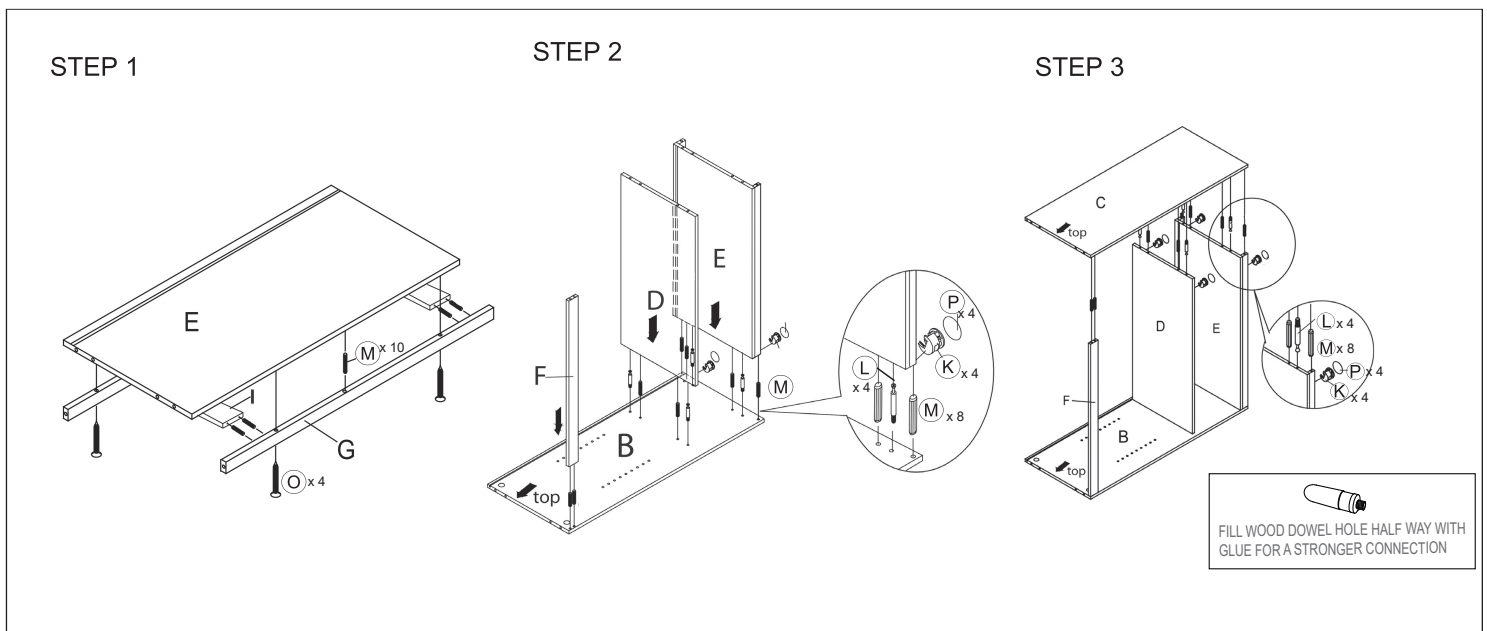

INSTRUCTIONS

STEP 4

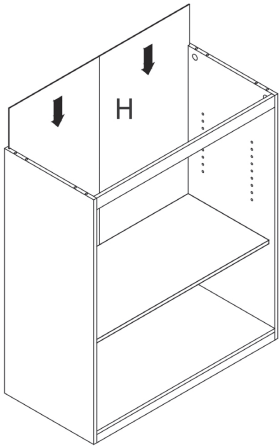

STEP 5

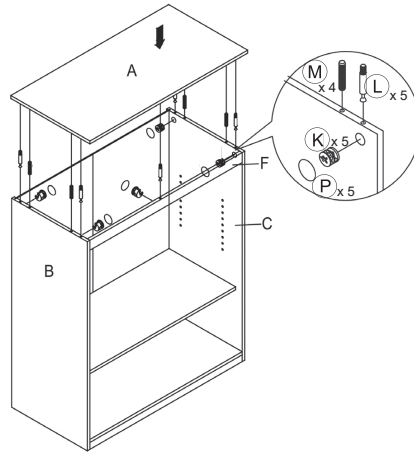

STEP 6

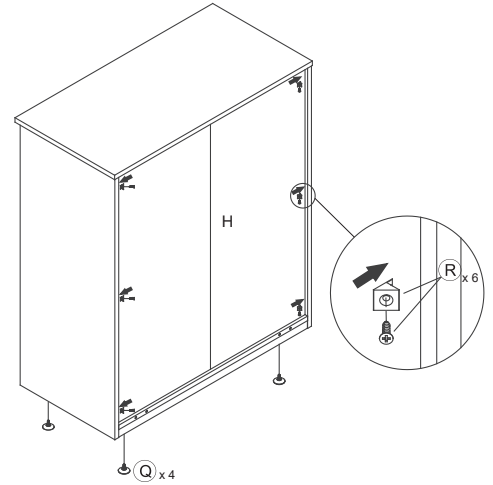

STEP 7

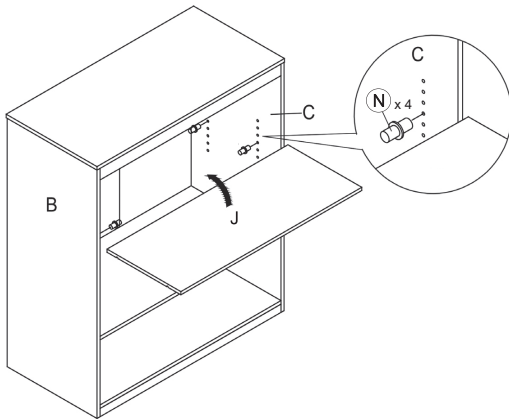

COMPLETED

