



BACK-UP ALARMS

Beacons | Lightbars | Minibars | Directional LEDs | Worklamps | Camera Systems

800 SERIES

Designed to meet all the harsh operational requirements of any fleets equipment, ECCO's 800 Series alarms feature a reverse-mounted speaker design and reinforced nylon housing providing unrivaled durability. These alarms are so robust that an ECCOLIFE™ warranty covering the alarm for the life of the vehicle is offered on all models. Smart Alarm® models measure ambient noise and adjust their sound level, creating a volume that is safe without being annoying or contributing to noise pollution. Smart Alarms eliminate the need for constant manual adjustment and help prevent intentional alarm disconnection.

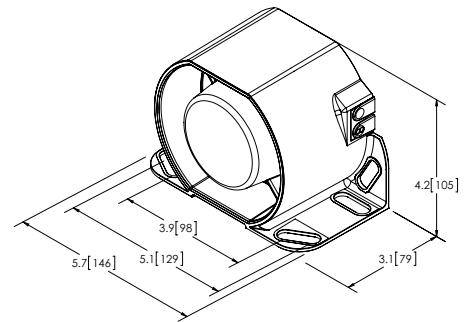

Models

PART NO.	VOLTAGE	dB(A)	AMPS	APPROVALS
SA917N	12-24	87-112	0.6	SAE Type F, CE, e
850N	12-36	112	1.7	SAE Type A, CE, e, UL, AMECA
830N	12-36	107	1.3	SAE Type B, CE, e, AMECA
840N	12-36	97/112	1.9	CE, e
820N	12-36	87/107	1.5	CE, e, UL

Features and Benefits

- Reverse mounted speaker enhances sound and protects the speaker from dust and moisture ingress
- Reinforced nylon housing eliminates corrosion damage
- Sealed in epoxy for protection against dust, moisture and vibration
- Steam cleanable and pressure washable
- Temperature Range: -40°F to +185°F (-40°C to +85°C)
- ECCOLIFE™ Warranty

Alarm Specifications

Connection: 16 AWG blunt cut wires
 Reinforced nylon housing
 Recommended mounting bolt:
 Bottom: 3/8-16 UNC Grade 5 or better
 Back: 5/16-18 UNC Grade 5 or better
 Recommended washer:
 Bottom: 3/8" Type A Series N washer
 Back: 5/16" Type A Series N washer
 Recommended mounting torque:
 Bottom: 276 in. lbs.
 Back: 156 in. lbs.

Need to find an alarm?
 There's an app for that.

Scan the QR Code to learn how or search ECCO Mobile in your app store.

