



	MODEL NO.	SERIAL NO.
VERTICAL DAVIT ASSEMBLY	506668	
DAVIT MOUNTING RECEPTACLE	506667	

# USER INSTRUCTIONS

## MSA VERTICAL MOUNT DAVIT SYSTEM

### ⚠ WARNING

*National standards and state, provincial and federal laws require the user to be trained before using this product. Use this manual as part of a user safety training program that is appropriate for the user's occupation. These instructions must be provided to users before use of the product and retained for ready reference by the user. The user must read, understand (or have explained), and heed all instructions, labels, markings and warnings supplied with this product and with those products intended for use in association with it. FAILURE TO DO SO MAY RESULT IN SERIOUS INJURY OR DEATH.*

## 1.0 VERTICAL MOUNT DAVIT AND COMPANION COMPONENTS MODELS AND SPECIFICATIONS

**TABLE 1. MSA VERTICAL MOUNT DAVIT SYSTEM MODELS COVERED BY THESE INSTRUCTIONS**

MODEL NUMBER	DESCRIPTION	MATERIAL	APPROXIMATE WEIGHT	
			LBS.	KG
506667	DAVIT MOUNTING RECEPTACLE	CARBON STEEL, ZINC PLATED	28.8	13
506668	VERTICAL DAVIT ASSEMBLY	CARBON STEEL, ZINC PLATED	44	20

**TABLE 2. MSA VERTICAL MOUNT DAVIT SYSTEM COMPANION COMPONENTS COVERED BY THESE INSTRUCTIONS**

MODEL NUMBER	DESCRIPTION	QTY PER ASSEMBLY	LIFELINE MATERIAL	APPROX WEIGHT	
				LBS.	KG
506218	DYNEVAC 95 FT	1 OR 2	STAINLESS STEEL	51	23
506558	DYNEVAC 50 FT	1 OR 2	STAINLESS STEEL	33	15
506261	DYNEVAC MOUNTING BRACKET 95'	1 OR 2	-	8	4
506627	DYNEVAC MOUNTING BRACKET 50'	1 OR 2	-	7	3
506426	DYNA-HOIST, SIDE MOUNT	0 OR 1	STAINLESS STEEL	49	22

### 1.1 SPECIFICATIONS - MSA VERTICAL MOUNT DAVIT SYSTEM

- For use on fixed steel ladders meeting OSHA 29CFR 1926.1050 and ANSI A14.3-1984. Rung spacing should be 12 inches (30.5 cm), clear distance between the side rails should be at least 16 inches (40.6 cm), clearance behind the ladder should be at least 7 inches (17.8 cm), and clearance on the climbing side of the ladder should be at least 30 inches (76.2 cm). The maximum intended load on the ladder must be determined by the qualified person responsible for the design, installation and use of the system. The criteria defining a qualified person are established by OSHA.
- Capacity is two persons, each weighing up to 310 lbs (141 kg) for personnel including weight of the user-borne objects. Maximum capacity is 620 lbs (242 kg).
- The vertical davit assembly and davit mounting receptacle, when used with the MSA Dyna-Lock or Dynevac, meet ANSI Z359.1-1992, ANSI A10.14-1991, and OSHA regulations dealing with fall arrest systems. These instructions and the labels on the product, fulfill the requirements of those standards and regulations.
- The vertical davit assembly and davit mounting receptacle meet the applicable requirements of OSHA regulation 29CFR1910.146 and ANSI Z117.1.
- The vertical davit assembly and davit mounting receptacle must be used together. They are designed to anchor a personal fall arrest system. They may also be used to lift and lower personnel and materials.
- Material used in construction of the vertical davit assembly and davit mounting receptacle is (a) square structural steel tubing conforming to ASTM A500, Grade B and , (b) steel plate conforming to ASTM A36. Welds conform to AWS code specification. Plating conforms to ASTM B633. Hardware conforms to ASA B18.2.1-1965; bolts are SAE Grade 5.

## 2.0 TRAINING

It is the responsibility of the purchaser of the vertical mount davit system to assure that product users are made familiar with these User Instructions and trained by a competent person in: (1) workplace hazard awareness and hazard identification, evaluation and control; (2) how to properly select, inspect, use, store and maintain the vertical davit and associated equipment; (3) how to select and make connections to anchorages and anchorage connectors; (4) proper attachment locations and proper attachment methods including compatibility of connections to reduce the probability of accidental disengagement ("rollout"); (5) how to evacuate from a hazardous space; (6) what to do after a fall to protect the user from injury, including emergency rescue planning and execution; and (7) the consequences of improper use of the equipment and of failure to follow instructions and training. If the vertical mount davit system is to be used for confined space applications, the user must also be trained in accordance with the requirements of OSHA regulation 29 CFR 1910.146 and ANSI Z117.1. Training must be conducted without undue exposure of the trainee to hazards. The effectiveness of training should be periodically assessed (at least annually) and the need for more training or retraining determined. MSA offers training programs. Contact MSA for training information.

## 3.0 HAZARDS IDENTIFICATION, EVALUATION AND CONTROL

### CAUTION

**Do not use the vertical mount davit system unless a qualified person has inspected the workplace and determined that use of the vertical davit is essential and that identified hazards can neither be eliminated nor exposures to them prevented.**

Prior to selecting a vertical mount davit system or other personal protective equipment, the user must make a workplace assessment of hazards and conditions where the equipment is required. Such assessment must, at a minimum, identify the presence of:

- Hot objects
- Sparks
- Flames
- Heat-producing operations
- Confined space hazards
- Chemicals
- Electrical hazards
- Environmental contaminants
- Sharp objects
- Abrasive surfaces
- Moving equipment
- Moving materials
- Unguarded openings
- Climatic factors
- Weather factors
- Unstable/uneven surfaces
- Slippery surfaces

Foreseeable changes in any of these conditions, taken individually or collectively, must be identified. The materials and construction of the vertical mount davit system and associated equipment must be considered in the selection process such that these workplace conditions are suitably addressed and responded to. The equipment must match the work situation and workplace environmental factors.

The workplace assessment must identify all paths of intended user movement and all hazards along such paths. The user must identify the required range of mobility in each hazard zone and note the location and distance to all obstructions in potential fall paths. Lateral obstructions which could be contacted in a pendular fall arrest must be noted. The self-retracting lanyard connecting the user's harness to the vertical davit anchorage connection must be selected so as to suitably limit total fall distance. If the vertical mount davit system are to be used for confined space entry operations, the workplace assessment must comply with the requirements of OSHA regulation 29 CFR 1910.146 and ANSI Z117.1.

## 4.0 DESCRIPTION OF VERTICAL MOUNT DAVIT SYSTEM AND COMPANION COMPONENTS

- 4.1 VERTICAL DAVIT ASSEMBLY:** The vertical davit consists of a plated tube with steel plates for attachment of companion components. At the top of the davit is a factory-installed D-ring anchorage connector. The removable davit is supported in the vertical position by the davit mounting receptacle. The vertical davit assembly is designed to permit attachment of one or two Dyna-Lock self-retracting lanyards, or Dynevac self-retracting lanyards with emergency rescuer. The davit will also support a side-mount Dyna-Hoist personnel and material hoist in combination with the Dyna-Lock or Dynevac.
- 4.2 DAVIT MOUNTING RECEPTACLE:** The davit mounting receptacle is the means by which the vertical davit assembly is attached to the ladder anchorage. The receptacle is permanently secured to three (3) rungs of the ladder by three (3) rung clamps, (provided), which bolt to threaded studs on the receptacle. The davit mounting receptacle is constructed of plated steel tube with inside dimensions which allow clearance for inserting the vertical davit assembly. A bolt is included to provide an adjustable stop for positioning the davit within the receptacle.
- 4.3 MOUNTING BRACKET FOR DYNEVAC/DYNA-LOCK:** The vertical davit assembly is equipped with two mounting plates for attachment of up to two (2) mounting brackets. The MSA P/N 506261 bracket fits the 95 ft (30 m) Dynevac and Dyna-Lock. The MSA P/N 506627 bracket fits the 50 ft (16 m) Dynevac and Dyna-Lock. The brackets are secured to the mounting plates with hardware provided on the vertical davit assembly. The mounting bracket is constructed of cast aluminum alloy.

- 4.4 DYNEVAC SELF-RETRACTING LANYARD WITH EMERGENCY RESCUER:** The Dynevac is a fall arrester of the retractable lifeline type with a built-in emergency rescue mechanism. The maximum capacity of the Dynevac is a single person whose total weight, including the weight of the user plus clothing, tools and other user-borne objects is 310 lbs (140 kg). Minimum capacity is 75 lbs (34 kg). Dynevac models are available in 50 ft (16 m) and 95 ft (30 m) line lengths. Wire rope lifeline may be ordered in either stainless steel or galvanized finish. A specially protected Roughneck™ Dynevac unit is available for use in corrosive environments. The Dynevac housing is zinc plated carbon steel. Internal components are principally carbon and alloy steel with a cast aluminum drum.
- 4.5 DYNA-LOCK SELF-RETRACTING LANYARD:** The Dyna-Lock is a fall arrester of the retractable lifeline type. The Dyna-Lock consists of a metal housing and wire-rope lifeline connected to a drum inside the housing. An internal spring causes the drum to wind-up the line when there is no load on the line. An internal locking mechanism is designed to lock the drum when the line is pulled out quickly, which will occur in the case of an accidental fall by the user. Capacity is one person, 75-310 lbs (34-140 kg). Dyna-Lock models are available in 30 ft (10 m), 50 ft (16 m), 70 ft (22 m), and 95 ft (30 m) line lengths. Wire rope lifeline may be ordered in either stainless steel or galvanized finish. A specially protected Roughneck™ Dyna-Lock unit is available for use in corrosive environments. The Dyna-Lock housing is zinc-plated carbon steel. Internal components are principally carbon and alloy steel with a cast aluminum drum.
- 4.6 DYNA-HOIST:** The MSA Dyna-Hoist is suitable for lifting, lowering and positioning materials when used with the vertical mount davit. The Dyna-Hoist capacity is 620 lbs (280 kg) for materials. Dyna-Hoist models are available with a variety of optional features. Standard features include an open drum wound with galvanized or stainless steel wire rope, in lengths of 40 ft (12 m), 80 ft (24 m), or 105 ft ( 32 m); reserve line on the drum to prevent overload on the point of termination; built-in shock absorber; clutched drive; triple braking system; steel housing and mounting bracket; self-locking swivel snaphook; and manual crank handle with anti-backlash brake.

VERTICAL MOUNT DAVIT SYSTEM

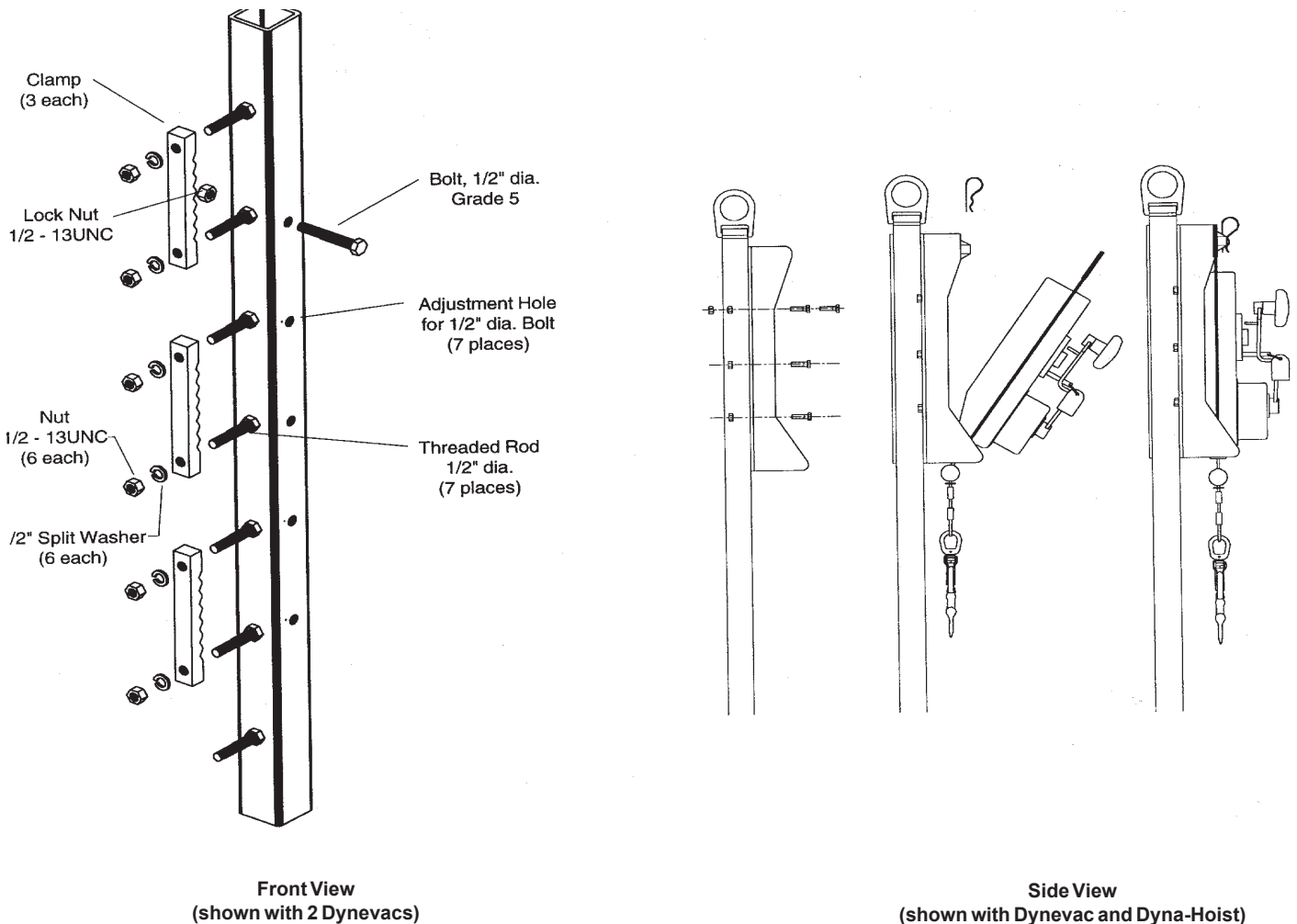

## 5.0 VERTICAL DAVIT MOUNTING SYSTEM SELECTION AND APPLICATIONS

- 5.1 PURPOSE OF THE VERTICAL DAVIT MOUNTING SYSTEM:** The primary purpose of the vertical mounting davit system is to serve as an anchorage connector for ladder climbing fall arrest and personnel rescue. Secondly, the vertical mounting davit system provides a means for anchoring a materials-handling hoist to a structural ladder and, thereby, enable lifting, lowering and suspension of materials from its location above a work space.

Use of the vertical mount davit system must comply with these User Instructions and, further, is subject to approval under the user's safety rules and regulations and by the user's safety director, supervisor, or a qualified safety engineer. Be certain the selection of the vertical mount davit system is suited for the intended use and work environment. If there is any conflict between these User Instructions and other directives or procedures of the user's organization, do not use the vertical mounting system until such conflicts are resolved. Consult all local, state, and federal Occupational Health and Safety Administration (OSHA) requirements for personal safety equipment. Also refer to the latest revision of ANSI Z359.1 and ANSI A10.14 standards for more information on anchorage connectors and associated system components. In Canada, refer to provincial and federal regulations.

- 5.2 USAGE LIMITATIONS:** The following application limitations must be considered and planned for before using the vertical mount davit system.
- 5.2.1 PHYSICAL LIMITATIONS:** The vertical mount davit system is designed for use by two person with a combined total weight less than 620 lbs (280 kg), including clothing, tools, and other user-borne objects. Persons with muscular, skeletal, or other physical disorders should consult a physician before using. Pregnant women and minors must never use the vertical mount davit system. Increasing age and lowered physical fitness may reduce a person's ability to withstand shock loads during fall arrest or prolonged suspension. Consult a physician if there is any question about physical ability to safely use this product to arrest a fall or suspend.
- 5.2.2 CHEMICAL HAZARDS:** Acidic, alkaline, or other environments with harsh substances may damage the plating and hardware elements of the vertical mount davit system. When working in the presence of chemicals, more frequent inspection of the vertical mount davit system is required.
- 5.2.3 CORROSION:** Do not expose the vertical mount davit system to corrosive environments for prolonged periods. Organic substances and salt water are particularly corrosive to metal parts. When working in corrosive environments, more frequent inspection, cleaning and drying of the vertical mount davit system is required. See sections 9, 11 and 12 for cleaning and inspection details.
- 5.2.4 ELECTRICAL HAZARDS:** Use extreme caution when working near energized electrical sources. Metal construction of the vertical mount davit system and other components connected to them will conduct electric current. Maintain a safe working distance {preferably at least 10 ft (3 m)} from electrical hazards.
- 5.2.5 MOVING MACHINERY:** When working about moving machinery (e.g. conveyors, rotating shafts, presses, etc.), maintain a safe working distance from machinery parts which could entangle clothing, this product, or other components connected to it.
- 5.2.6 WEAR AND DETERIORATION:** Any vertical mount davit system which shows signs of excessive wear or deterioration must be removed from use and marked "UNUSABLE" until destroyed. See sections 11 and 12 for detailed inspection procedures.
- 5.2.7 IMPACT FORCES:** Any vertical mount davit system which has been subjected to the forces of arresting a fall must be immediately removed from service and marked as "UNUSABLE" until (a) inspected and determined by a competent person to be undamaged and suitable for reuse, or (b) returned to MSA for repair.
- 5.2.8 GENERAL PRECAUTIONS:**
- This system must be installed and used under the supervision of a qualified person.
  - Use only with a suitable steel structural ladder.
  - Use only with compatible MSA components.
  - Do not expose the worker to hazard during installation and removal of the vertical mount davit system.
  - Connect no more than two (2) personal fall arrest subsystems to the vertical mount davit system at one time.

## 6.0 SYSTEMS REQUIREMENTS

The vertical mount davit assembly and davit mounting receptacle are components of multi-component systems. Without the other necessary components, they serve no useful purpose. The vertical mount davit assembly and davit mounting receptacle are used in climbing protection and rescue. They may also be used in material handling. In general, however, the vertical mount davit assembly and davit mounting receptacle are not intended for use in restraint, evacuation or personnel riding.

- 6.1 SYSTEM TYPES:** Systems are classified according to their intended purposes. There are six classifications of systems which may be used individually or in combinations. The six basic systems classifications are:
- Personnel-riding
  - Climbing protection
  - Fall Arrest
  - Restraint
  - Rescue
  - Evacuation
- 6.1.1 PERSONNEL-RIDING SYSTEMS:** A personnel-riding system is an assembly of components and subsystems, including the necessary connectors, used for lifting and lowering a worker to and from a work station which is not accessible by other preferred means, and potentially for positioning the worker while at that work station. Personnel-riding systems are of two general types, namely: (a) the mobile supported aerial platform type (e.g. manually- and self-propelled platforms and vehicle-mounted platforms), and (b) suspended personnel hoisting type (e.g. suspended scaffolds, suspension seats, and suspension harnesses). When working on mobile supported aerial platforms, the user should use a restraint system (see section 6.1.3) anchored to the platform to provide restraint against falling from the platform. When working with the suspended personnel hoisting type of system, the user should use a back-up a fall arrest system of either the self-retracting lanyard type or the fall arrester (rope grab) type. Contact MSA for separate instructions on the associated equipment used in personnel-riding systems. **The vertical mount davit system is not suitable for use in personnel-riding systems.**
- 6.1.2 FALL ARREST SYSTEMS:** A fall arrest system is an assembly of components and subsystems, including the necessary connectors, used to arrest the user in a fall from a working height and suspend the user until rescue can be effected. A fall arrest system must always include a harness and connecting means between the harness and an anchorage or anchorage connector. Such connecting means may consist of a lanyard, energy (shock) absorber, fall arrester (rope grab), lifeline, self-retracting lanyard or suitable combinations of these.
- 6.1.2.1 Lanyard Connecting Subsystem** is the term applied to an assembly, including the necessary connectors, which is comprised of a lanyard and a shock absorber. The lanyard and shock absorber are usually permanently coupled together along with self-locking snaphooks at each end. The subsystem is attached between the fall arrest attachment (back D-ring) of the harness and an anchorage or anchorage connector. **The vertical mount davit system is not included in lanyard connecting subsystems.**
- 6.1.2.2 Fall Arrester Connecting Subsystem** is the term applied to an assembly, including the necessary connectors, which is comprised of a fall arrester (rope grab) and a vertical lifeline. Sometimes a lanyard or lanyard with integral shock absorber, including the necessary connectors, is connected to the rope grab. The vertical lifeline must have a lifeline tensioner (counterweight), a connector for anchoring it, and may have a shock absorber. The subsystem is attached between the fall arrest attachment (back D-ring) of the harness and an anchorage or anchorage connector. Fall arrester connecting subsystems are sometimes suitable for use in climbing protection systems. See section 6.1.2. Contact MSA for information on shock absorbing lanyards that are suitable for use in fall arrester connecting subsystems. **The MSA vertical mount davit system is not included in fall arrester connecting subsystems.**
- 6.1.2.3 Self-Retracting Lanyard Connecting Subsystem** is the term applied to an assembly, including the necessary connectors, comprised of a self-retracting lanyard only or a self-retracting lanyard and added shock absorber at the point of attachment to the user's harness. The subsystem is attached between the fall arrest attachment (back D-ring) of the harness and an anchorage or anchorage connector. These subsystems are sometimes suitable for use in climbing protection systems. See section 6.1.2. **The vertical mount davit system is suitable for use in self-retracting lanyard connecting subsystems.**
- 6.1.3 RESCUE SYSTEMS:** A rescue system is an assembly of components and subsystems, including the necessary connectors, used for moving an incapacitated or isolated person from a hazardous place to a safe place under alert or emergency conditions. An isolated person is one who has no available means of access to a safe place or is physically stranded or trapped. Rescue systems require actions of specially trained rescuers to effect the rescue of the incapacitated or isolated person. **The vertical mount davit system is suitable for use in rescue systems.**
- 6.1.4 CLIMBING PROTECTION SYSTEMS:** A climbing protection system is an assembly of components and subsystems, including the necessary connectors, used to arrest the user in a fall from a working height and suspend the user until rescue can be effected. Such systems are used for climbing ladders and structures that are designed for climbing. They may either be temporary (portable) or permanent. Temporary climbing protection systems are described in sections 6.1.7.2 and 6.1.7.3. Permanent climbing protection systems are ones of the rigid rail type such as the MSA Dyna-Glide systems. In those systems, a rigid rail is permanently attached to the structure to be climbed. A fall arrester device is attached to and glides on the rail to permit ascent and descent. It quickly locks in case of a fall. The Dyna-Glide fall arrester is attached between the front attachment (chest D-ring) of a MSA Pullover harness and the fall arrester by use of a carabiner. Contact MSA for more information about Dyna-Glide climbing protection systems. **The vertical mount davit system Dyna-Lock/Dynevac mounting bracket attachment point is a suitable anchorage connector in a temporary climbing protection system.**
- 6.1.5 RESTRAINT SYSTEMS:** A restraint system is an assembly of components and subsystems, including the necessary connectors, used to:

(a) stabilize and partially support the user at an elevated work location and allow free use of both hands. This type of restraint system is referred to as a work positioning system or, simply, a positioning system.

(b) restrict the user's motion so as to prevent reaching a location where a fall hazard exists. This type of system is referred to as a travel restriction system.

A positioning system includes a harness and connecting means between the harness and an anchorage or anchorage connector. Such connecting means usually consists of a positioning lanyard which is connected to both hip D-rings and wraps around or connects to an anchorage or anchorage connector. A positioning system must always be backed up by a fall arrest system. A travel restriction system consists of a harness and a fixed-length or adjustable-length lanyard connected between any one of the harness D-rings and an anchorage or anchorage connector. **The vertical mount davit system should not be used for work positioning nor for travel restriction.**

- 6.1.6 EVACUATION SYSTEMS:** An evacuation system is an assembly of components and subsystems, including the necessary connectors, employed by the user to move, unassisted by others, from a hazardous place to a safe place under alert or emergency conditions. An evacuation system consists of a harness and connecting means between the harness and an anchorage or anchorage connector. Such connecting means may consist of: (a) the MSA Dynescape™ Automatic Descender, (b) the MSA Dynescape™ Manual Descender, or (c) the MSA Fallbloc™ System. See the separate instructions for this equipment. **The vertical mount davit system is generally not used in evacuation systems.**
- 6.1.7 COMBINATIONS OF SYSTEMS:** Systems for fall arrest, restraint, climbing protection, personnel-riding, rescue and evacuation are often used in combination. For example, positioning type restraint systems must be backed up by a separate and independent fall arrest system. Hands-on training is required to obtain the necessary information and skills needed to work with combinations of systems. Refer to the separate instructions accompanying the several components and subsystems necessary to make up these systems.
- 6.1.7.1 Vertical mount davit material handling system** consists of the vertical mount davit system with MSA side-mounted Dyna-Hoist. This system is intended to only be used to lift and lower materials.
- 6.1.7.2 Vertical mount davit climbing protection and rescue system** consists of the vertical mount davit system with MSA Dynevac and MSA Dynevac mounting bracket. This system is intended to be used to arrest the user in a fall from a working height and effect a rescue of the user.
- 6.1.7.3 Vertical mount davit climbing protection system** consists of the vertical mount davit system with MSA Dyna-Lock and MSA Dyna-lock mounting bracket. This system is intended to be used to arrest the user in a fall from a working height and suspend the user until rescue can be effected.

## 6.2 COMPATIBILITY OF SYSTEM PARTS

- 6.2.1 COMPATIBILITY OF COMPONENTS AND SUBSYSTEMS:** MSA vertical mount davit system is designed to be used with other MSA approved components and connecting subsystems. Use of the vertical mount davit system with products made by others that are not approved in writing by MSA may adversely affect the functional compatibility between system parts and the safety and reliability of the complete system. Contact MSA with any questions regarding compatibility of equipment used with the vertical mount davit system.
- 6.2.2 COMPATIBILITY OF CONNECTORS:** Connectors, such as D-rings, snaphooks, and carabiners, must be rated at 5,000 lbf (22 kN) minimum breaking strength. MSA connectors meet this requirement. Connecting hardware must be compatible in size, shape, and strength. Non-compatible connectors may accidentally disengage ("rollout").
- 6.2.3 ANCHORAGES AND ANCHORAGE CONNECTORS:** An anchorage is generally a fixed structural member such as a beam, girder, column, floor, or wall. **The vertical mount davit system is an anchorage connector for for personal fall arrest systems.** Anchorages and anchorage connectors for personal fall arrest systems must have a strength capable of supporting a static load, applied in directions permitted by the system, of at least: (a) 3,600 lbf (16 kN) when certification exists, or (b) 5,000 lbf (22.2 kN) in the absence of certification. See ANSI Z359.1 for definition of certification. When more than one personal fall arrest system is attached to an anchorage, the anchorage strengths set forth in (a) and (b) must be multiplied by the number of systems attached to the anchorage. See ANSI Z359.1, section 7.2.3. This requirement is consistent with OSHA requirements under 20 CFR 1910, Subpart F, Section 1910.66, Appendix C. In addition, it is recommended that the user of personal fall arrest systems refer to ANSI Z359.1, Section 7, for important considerations in equipment selection, rigging, use, and training.

## 7.0 PLANNING THE USE OF SYSTEMS

Perform the hazard identification and evaluation described in section 3.0 of these instructions. Then plan the system(s) before

starting work. Consider all possible paths of user movement and all factors that could affect the user's safety before, during, and after a fall anywhere along these paths. A qualified person must select the components, materials, anchorage and anchorage connectors to match the system application, the work, workplace hazards, and the environment. Consider the following points when planning the system(s).

- 7.1 ANCHORAGE AND ANCHORAGE CONNECTOR SELECTION:** Determine the necessary locations of anchorages to assure that the user will be continuously connected when exposed to hazards of falling. Select anchorages that are stable and have the strength required by section 6.2.3 of these instructions. Carefully select the locations of the anchorages to: (a) reduce possible free fall distance, (b) prevent swing fall hazards, and (c) provide clear space in the potential fall paths to avoid striking an object. Do not select anchorage locations that will require the user to work above them as this will increase the potential free fall and total fall distances. Plan the types of anchorage connectors that will need to be selected and refer to those instructions.
- 7.2 FREE FALL DISTANCE, TOTAL FALL DISTANCE, AND SYSTEM ELONGATION:** Personal fall arrest systems must be selected and rigged to ensure that potential free fall distances will never exceed 6 ft (1.8 m) as required by OSHA and ANSI Z359.1. [In Canada, free fall distance is limited to 5 ft (1.5 m) by regulation. ANSI A10.14 also restricts free fall distance to 5 ft (1.5 m).] Total fall distance is the sum of free fall distance and deceleration distance. Dynamic elongation of the system (temporary elastic stretch of connecting components and subsystems) must be included in the total fall distance and the user must allow for clearance.
- 7.3 USER MOVEMENTS:** Identify all necessary movements of the user and the materials and equipment needed to perform the planned work. Plan for avoidance of the crossing or tangling of connecting subsystems of two or more workers. Anticipate user movements that might introduce hazards of the connecting subsystem passing under, about or between body parts or invite the user to clamp, knot or otherwise prevent the connecting subsystem from functioning properly. Establish controls to prevent these occurrences.
- 7.4 PENDULUM (SWING) FALLS:** Swing falls can occur when the system is not anchored directly above the user. The force of striking an object in a pendular motion can cause serious injury. Always minimize swing falls by working as directly below the anchorage point as possible.

#### Swing Fall Hazard

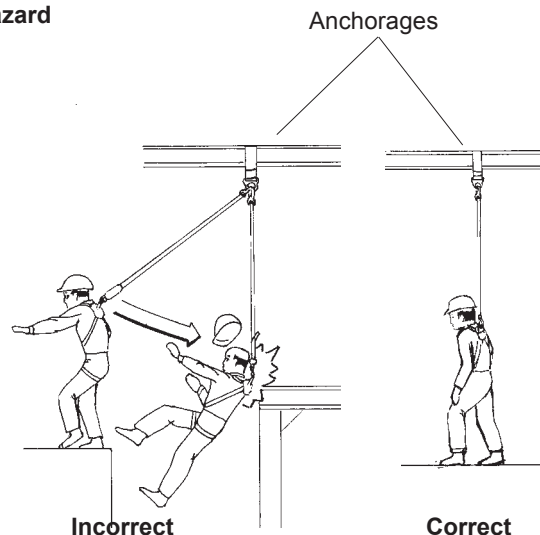

Swing fall hazards must be minimized by anchoring directly above the user's work space.

- 7.5 CLEAR SPACE IN FALL PATH:** Make certain that enough clearance is available in all potential fall paths to prevent striking an object. The amount of clearance needed depends upon the type of connecting subsystem used, and the location of the anchorage. Allow at least 40 in (1 m) below the user and within a radius of 6 ft (1.8 m). This allows for some horizontal motion during the fall even if there is no swing fall possible.
- 7.6 HAZARDS IDENTIFIED IN WORKPLACE ASSESSMENT:** All hazards of the type set forth in section 3 of these instructions must be addressed and suitable controls planned and implemented. For example, if work must be performed near unavoidable sharp edges, plan to protect against cutting by use of heavy padding or other means of covering the sharp edge.

- 7.7 RESCUE AND EVACUATION:** The user must have a rescue plan and the means at hand to implement it. The plan must take into account the equipment and special training necessary to effect prompt rescue under all foreseeable conditions. If the rescue be from a confined space, the provisions of OSHA regulation 1910.146 and ANSI Z117.1 must be taken into account. Although a rescue plan and the means to implement it must always be in place, it is a good idea to provide means for evacuation without assistance of others. This will usually reduce the time to get to a safe place and reduce or prevent the risk to rescuers. The vertical mount davit system is suitable for use in rescue systems but not are used in evacuation systems.

## 8.0 INSTALLATION AND USE

### CAUTION

**Do not expose workers to fall hazards during installation. A separate personal fall arrest system is required for each installation worker. The vertical mount davit system must be installed and used under the supervision of a qualified person.**

- 8.1 INSTALLING THE DAVIT MOUNTING RECEPTACLE:** Equipment required to complete the installation includes: wrench, 3/4 inch size.
- Step 1:** Align davit mounting receptacle vertically with the top to the receptacle as close to the topside working surface as practical. Receptacle must engage three (3) ladder rungs .
- Step 2:** Center the davit mounting receptacle between the ladder side rails. The steel receptacle tube must be placed on the climbing side of the ladder, threaded rods facing toward the inside of the ladder. Label is on top, facing out.
- Step 3:** Assemble the alligator clamps, three (3) per davit mounting receptacle. The teeth of the clamps engage the ladder rungs. Attach lock washer and nut (provided) to the end of each threaded stud. Tighten the nuts to at least 50 pound foot (67 N-m) torque.
- Step 4:** Inspect the installation. Verify all parts are present and properly secured before use. **(Refer to Figure 1)**
- 8.2 ATTACHING THE DYNEVAC TO THE VERTICAL DAVIT ASSEMBLY:** Equipment required to complete the installation includes: wrenches, open-end/box-end socket, 9/16 inch size and 17 mm size.
- Step 1:** Assemble the Dynevac mounting bracket, P/N 506261 or 506627, using the four (4) hex bolts and lock-nuts provided. (The hole pattern of the Dynevac mounting bracket will match the corresponding bolt holes in the davit mounting bracket.) Apply 31 pound foot ( 42 N-m) torque to tighten bolts. Repeat this step for the second Dynevac mounting bracket, if necessary.
- Step 2:** Detach the stabilizer grip form the Dynevac housing by removing the 17 mm hex nut.
- Step 3:** Install the vertical davit assembly into the davit mounting receptacle as described in section 8.3.
- Step 4:** Lay the Dynevac on the ground beside the vertical davit. While holding the ball-stopper, extract line from the Dynevac. Pass line through the slotted opening of the Dynevac Mounting Bracket. The ball-stopper will hold the line in position while you raise the Dynevac into position on the mounting bracket. Place the Dynevac nozzle through the opening in the mounting bracket (nozzle faces down). Push the Dynevac handle against the mounting bracket boss. Secure the Dynevac with the cotter pin attached to the Dynevac bracket.
- Step 5:** Inspect the Dynevac attachment. Verify that all parts are present and properly secured before use. **(Refer to Figure 2)**

### CAUTION

**Read and understand Dynevac User Instructions, P/N 620948, before using this equipment.**

- 8.3 INSTALLATION OF THE VERTICAL DAVIT ASSEMBLY:** Equipment required to complete the installation includes: wrench, 3/4 inch size. The davit mounting receptacle must be installed on the ladder anchorage prior to beginning this step, see section 8.1. The Dynevac/Dyna-Lock brackets should be attached to the davit before beginning this step, see section 8.2. Approximately 8 ft (2.4 m) of overhead clearance is required to install the vertical davit.
- Step 1:** Lift the vertical davit assembly straight above the davit mounting receptacle and lower the davit slowly into the receptacle tube.
- Step 2:** Adjust the height of the vertical davit assembly and place the 1/2 inch diameter Grade 5 bolt (provided) into one of



the seven (7) holes of the davit mounting receptacle. Secure the bolt with the lock nut provided.

**Note:**The davit height must be low enough to permit the operation of the Dynevac crank handle during emergency retrieval. The height of the davit must also be sufficient to allow clearance of the hips of the suspended person above the top of the ladder in the event of an emergency rescue. A series of seven (7) holes are located along the side of the davit mounting receptacle to permit adjustment of the vertical davit to its optimum height. **(Refer to Figure 3)**

**8.4 INSTALLATION OF THE DYNA-HOIST:** A Dyna-Hoist retrofit for the vertical davit mounting system (P/N 506xxx) is required to attach the MSA Dyna-Hoist to the davit mounting assembly. Installation of the retrofit kit requires use of a small blade screwdriver. No special tools are required to install the Dyna-Hoist once the retrofit kit is in place.

**Step 1:** Lift the Dyna-Hoist with the snaphook facing down, and slip the angle bracket of the hoist onto the vertical davit assembly. The bottom edge of the angle bracket should rest on a stop welded for this purpose on the side of the davit tube.

**Step 2:** Pin the Dyna-Hoist angle bracket with the ball-lock pin provided on the hoist. Then pin the Dyna-Hoist through the hole in the davit tube using the ball lock pin provided in the retrofit kit.

**Step 3:** Inspect the Dyna-Hoist installation. The cable opening must be facing down, with the hoist cranking handle to the right side when standing topside facing the vertical mounting davit assembly. The handle should turn without interference from other equipment mounted to the davit. Verify all parts are present and properly secured prior to use. **(Refer to Figure 4)**

**CAUTION**

Read and understand Dyna-Hoist User Instructions P/N 621852, before using this equipment.

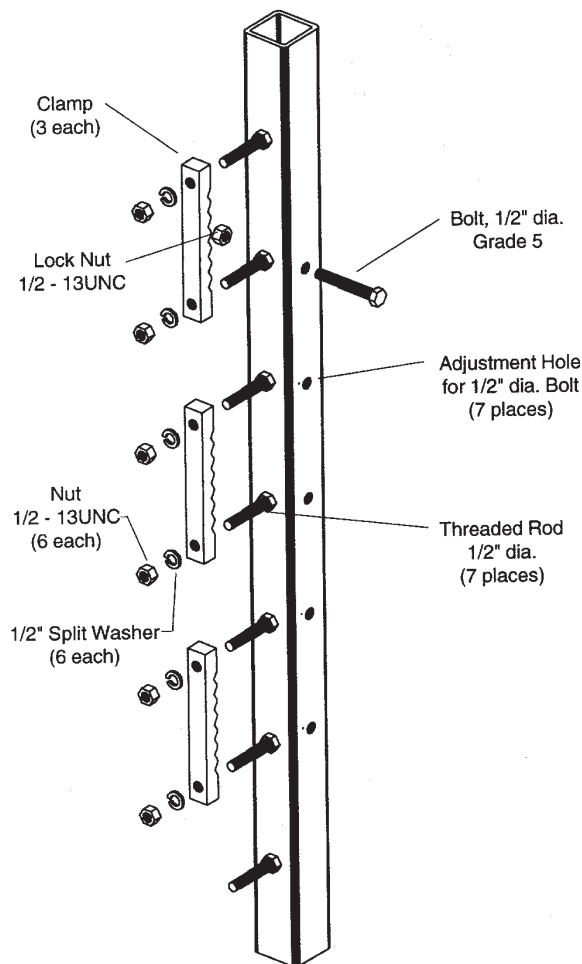

**Figure 1**  
Davit Mounting Receptacle (P/N 506667)  
Exploded View

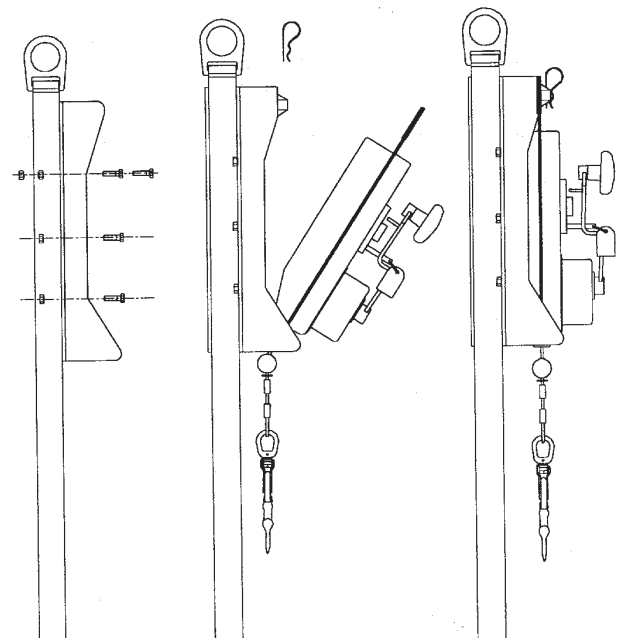

**Figure 2**  
Attaching Dynevac to the  
Dynevac/Dyna-Lock Bracket

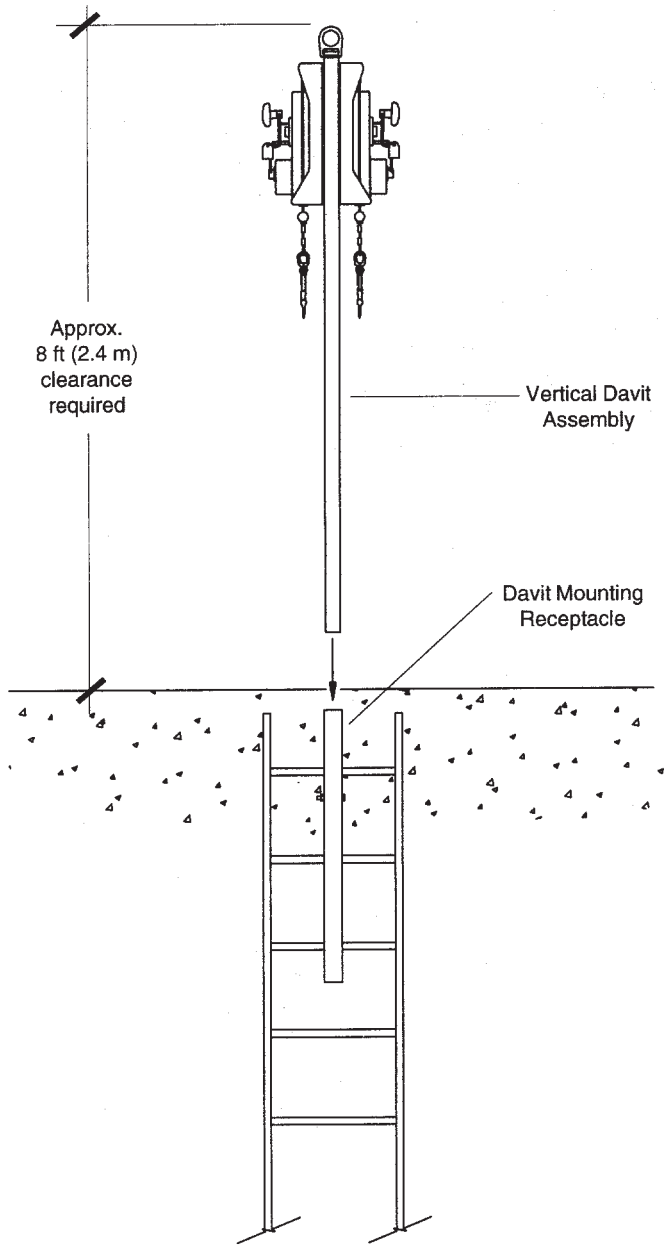

**Figure 3**  
Installing  
Vertical Davit Assembly (P/N 506668)  
into Davit Mounting Receptacle

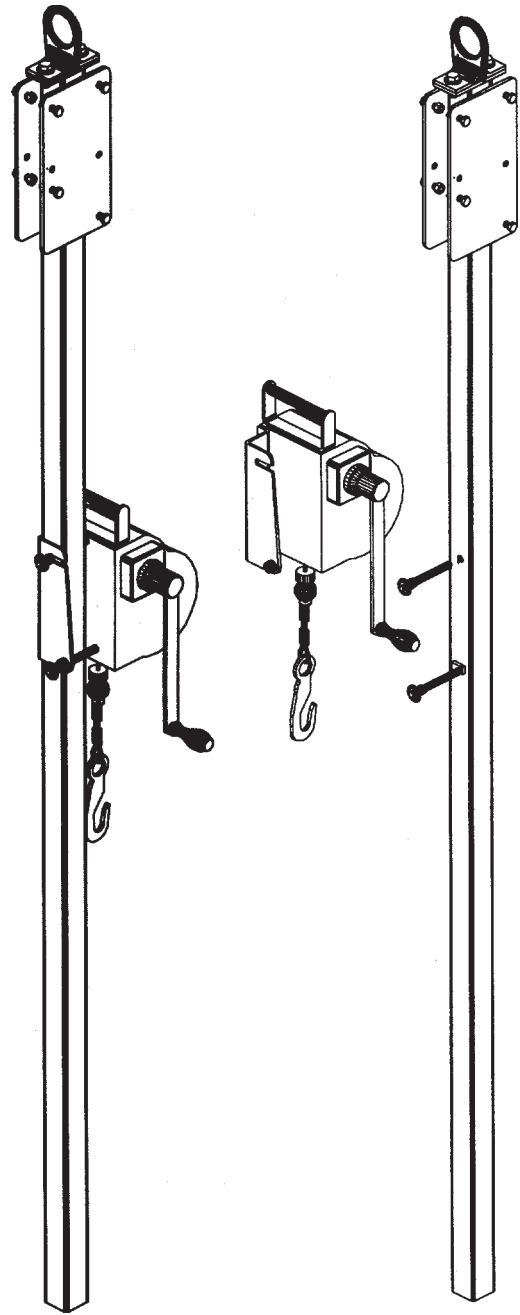

**Figure 4**  
Installing  
Side Mount Dyna-Hoist  
onto Vertical Davit Assembly

## 8.4 INSTRUCTIONS FOR USE:

### CAUTION

- Do not exceed the maximum capacity of 620 lbs (282 kg) including personnel and material.
- Do not connect more than two persons to the vertical davit mounting system at one time.

**8.4.1 LADDER CLIMBING FALL ARREST:** Connect the swivel snaphook of the Dynevac/Dyna-Lock self retracting lanyard (SRL) to the front (chest) D-ring of the worker's full body harness. Connect to the SRL before entering the fall hazard zone. When ladder climbing, the SRL will automatically pay out and reel-in line. Do not allow a slack-line condition to develop; lifeline must be under tension while climbing. Use care to avoid tangling the line of another worker on the same system. When not in use, the SRL line should be allowed to retract back into the housing.

In the event of a fall, the SRL will lock automatically, arresting the fall within 24 inches (61 cm). The worker should regain contact with the ladder, if possible, and immediately evacuate to a safe working level. If the suspended worker is incapacitated, rescue efforts must be initiated (see section 8.4.2). Once the vertical mount davit system has been exposed to the forces of arresting a fall, the components must be removed from service and labeled "UNUSABLE" until examined and disposition made by a competent person within the user's organization. Contact MSA with any questions regarding the suitability for use of vertical mount davit system components.

**8.4.2 EMERGENCY RESCUE:** When the Dynevac is in use, rescue of an incapacitated worker may be performed by engaging the Dynevac in Rescue Mode. Refer to the Dynevac User Instructions for detailed procedures. Rescue may be by lifting or lowering to the nearest safe working level. If the suspended worker is raised to the top of the ladder for rescue, the person must be lifted to a height so that his hips clear the top of the ladder. The topside rescue worker must be provided with his own, separate, fall arrest subsystem anchored to the D-ring on top to the vertical davit. Additional rescue personnel must also be provided with the means to protect against potential fall hazards during rescue.

**8.4.3 MATERIALS LIFTING AND LOWERING:** The MSA Dyna-Hoist is used in conjunction with the vertical mount davit system for lifting and lowering materials up to 620 lbs (280 kg) capacity. Attach the load to the Dyna-Hoist swivel snaphook. The topside worker must be equipped with a personal fall arrest subsystem connected to the D-ring on top of the vertical davit. Detailed operating instructions are included in the Dyna-Hoist User Instructions (P/N 621852).

Limit total load on the vertical mount davit system to 620 lbs (280 kg) when using the hoist in combination with a personnel fall arrest Dynevac/Dyna-Lock. Use care to avoid crossing or tangling lines. Do not leave suspended loads on the hoist unattended. When not in use, the hoist line should be reeled back onto the drum. The Dyna-Hoist must be removed from the davit before lifting an incapacitated worker topside during rescue.

### CAUTION

When lifting or lowering materials, NEVER suspend loads above a worker on the vertical mount davit system.

**8.4.4 DISASSEMBLING THE VERTICAL MOUNT DAVIT SYSTEM:** To disassemble the components of the vertical mount davit system, reverse the steps in the installation instructions given earlier in section 8.4. Do not leave the components of the system in place for prolonged periods in a corrosive environment. Inspect the system at disassembly, as described in section 11, before stowing. Stow the equipment in a clean dry area when not in use.

## 9.0 CARE, MAINTENANCE, AND STORAGE

User maintenance consists of cleaning and drying the vertical mount davit system. All other maintenance or repair work must be done at the factory or by persons authorized in writing by MSA.

**9.1 CLEANING INSTRUCTIONS:** To clean, periodically use a clean damp (not wet) cloth to remove dirt or contamination which may cause corrosion or hamper readability of labels. Wipe off any moisture before returning the device to service. The frequency of cleaning should be determined by inspection and by severity of the environment. In highly corrosive environments cleaning should be done every two or three days. Never use solvents to clean vertical mount davit system as they may break down the label adhesive. Don't use abrasives to scour the vertical mount davit system as they may damage the plating and the labels. To remove oil or grease, use a mild dishwasher detergent on a damp cloth or sponge and follow by repeated swabbing with a clean damp cloth to remove all soap residue. Never immerse the product in water or other liquid.

**9.2 STORAGE:** Store the device in a clean, dry place indoors. Store the product away from heat and steam and never allow it to rest for lengthy periods of time on concrete or ash floors as the lime sulfur and ash can cause corrosion.

**10.0 MARKINGS AND LABELS**

10.1 The following labels must be present, legible, and securely attached to the vertical mount davit system.

**VERTICAL DAVIT ASSEMBLY**  
**Rose**

**Model:** 506668  
**Material:** Carbon Steel, Zinc Plated  
**Capacity:** Two person, each with a combined total weight no greater than 310 lbs (141 kg), including clothing, tools, and other user-borne objects. Max. capacity is 620 lbs (282 kg).  
**Length:** 7.5 ft (2.3 m)  
**Approx. net weight:** 44.0 lb (20.0 kg)

Use only with Rose Davit Mounting Receptacle (P/N 506667). Compatible with Rose Dynevac self-retracting lanyard with emergency rescuer.

**INSTALLATION-**  
**Step 1:** Assemble the Dynevac Flat Mounting Brackets (2) using hardware provided.  
**Step 2:** Davit Mounting Receptacle (P/N 506667) must be installed on ladder anchorage according to User Instructions (P/N 623053).  
**Step 3:** Lift Vertical Davit and lower into Davit Mounting Receptacle.  
**Step 4:** Adjust height of davit and insert 1/2" diameter Grade 5 bolt (provided) into davit receptacle. Secure with lock nut provided. Davit height must be low enough to permit the use of the Dynevac crank handle for emergency retrieval.  
**Step 5:** Mount Dynevac brackets according to User Instructions (P/N 620948).  
**Step 6:** Inspect completed davit installation. Verify all parts are present and properly secured before use.

**INSTRUCTIONS FOR USE -**

- Connect Dynevac snaphook to front (chest) D-ring of fullbody harness.
- Dynevac must be in fall arrest mode for ladder climbing. Engage handle for lifting and lowering only during emergency retrieval.
- Remain connected to self-retracting lanyard lifeline when climbing. Dynevac lifeline should be retracted into unit when not in use.
- To rescue, follow instructions on Dynevac label. Suspended person must be lifted as close as possible to working surface. Rescuer must be attached to D-ring anchorage connector when engaged in lifting or lowering.

<b>DATE OF MANUFACTURE</b>				
YR	1996	1997	1998	1999
MTH	JAN	FEB	MAR	APR
	MAY	JUN	JUL	AUG
	SEP	OCT	NOV	DEC

Rose Manufacturing Co.,  
 2250 S. Tejon St., Englewood,  
 CO 80110-1000,  
 1-800-722-1231 P/N 623049

**VERTICAL DAVIT ASSEMBLY ID and Caution Labels**

**CAUTION**

READ AND HEED ALL INSTRUCTIONS, LABELS, MARKINGS AND WARNINGS SUPPLIED WITH THIS PRODUCT AND WITH THOSE PRODUCTS INTENDED FOR USE IN ASSOCIATIONS WITH IT. **FAILURE TO DO SO MAY RESULT IN SERIOUS INJURY OR DEATH.**

- For personnel use only, not for materials handling.
- Do not exceed maximum working loads. See User Instructions and davit labels.
- Install and use under the supervision of a qualified person. Have a rescue plan. Users must be trained in fall protection, lifting/lowering, communication, rescue and evacuation procedures.
- Do not use near electrical hazards.
- Wire rope lifelines must not contact sharp edges or abrasive surfaces.

**INSPECTION-**  
 Before each use inspect entire davit, including attached Dynevac, according to User Instructions. Look for damage, alteration, missing or broken parts, excessive wear and corrosion. Inspect ladder and ladder stand-offs for cracks, breaks, loose or missing parts. **Never use davit if any of these conditions exist.** Do not attempt field repairs of davit assembly. Formally inspect by a competent person other than the user at least every six months. Note successful completion of formal inspection by punching date on grid. If davit fails inspection, remove from use and label "UNUSABLE" until repaired or destroyed.

**CAUTION**

**FORMAL INSPECTION GRID**

	J	F	M	A	M	J	J	A	S	O	N	D
96												
97												
98												
99												
00												

PUNCH GRID ON DATE OF FIRST USE

<b>DATE OF MANUFACTURE</b>				
YR	1996	1997	1998	1999
MTH	JAN	FEB	MAR	APR
	MAY	JUN	JUL	AUG
	SEP	OCT	NOV	DEC

Rose Manufacturing Co.,  
 2250 S. Tejon St., Englewood,  
 CO 80110-1000,  
 1-800-722-1231 P/N 623050

**DAVIT MOUNTING RECEPTACLE**  
**Rose**

**Model:** 506667  
**Material:** Carbon Steel, Zinc Plated  
**Capacity:** Two person, each with a combined total weight no greater than 310 lbs (141 kg), including clothing, tools, and other user-borne objects. Max. capacity is 620 lbs (282 kg).  
**Length:** 41 in (104 cm)  
**Approx. net weight:** 28.8 lb (13.0 kg)

Use only with Rose Vertical Davit Assembly (P/N 506668).

**INSTALLATION-**  
 Note: The installation and use of the vertical mount davit system must be performed under the supervision of a qualified person. Select a ladder anchorage of suitable strength and size to install this fall-rescue-work system. Refer to User instructions provided with this product.  
**Step 1:** Align davit mounting receptacle vertically on ladder with the top of the receptacle as close to the topside working surface as practical. Mounting holes (7) are in the middle of receptacle.  
**Step 2:** Center receptacle on ladder rungs with steel tube on the outside of ladder, threaded rods facing toward wall.  
**Step 3:** Assemble alligator clamps (3 each) to threaded rods on receptacle. Attach lock washer and nut to end of each threaded rod and tighten nuts to at least 50 pound-foot (67 N\*m) torque.  
**Step 4:** Insert vertical davit into receptacle and adjust to proper height. Place 1/2" dia Grade 5 bolt (provided) through holes in receptacle. Davit rests on top of bolt. Secure bolt with lock nut provided.  
**Step 5:** Inspect completed davit installation. Verify all parts are present and properly secured before use.

<b>DATE OF MANUFACTURE</b>				
YR	1996	1997	1998	1999
MTH	JAN	FEB	MAR	APR
	MAY	JUN	JUL	AUG
	SEP	OCT	NOV	DEC

Rose Manufacturing Co.,  
 2250 S. Tejon St., Englewood,  
 CO 80110-1000,  
 1-800-722-1231 P/N 623051 Rev B

**DAVIT MOUNTING RECEPTACLE ID and Caution Labels**

**CAUTION**

READ AND HEED ALL INSTRUCTIONS, LABELS, MARKINGS AND WARNINGS SUPPLIED WITH THIS PRODUCT AND WITH THOSE PRODUCTS INTENDED FOR USE IN ASSOCIATIONS WITH IT. **FAILURE TO DO SO MAY RESULT IN SERIOUS INJURY OR DEATH.**

- For personnel use only, not for materials handling.
- Do not exceed maximum working loads. See User Instructions and davit labels.
- Install and use under the supervision of a qualified person. Have a rescue plan. Users must be trained in fall protection, lifting/lowering, communication, rescue and evacuation procedures.
- Do not use near electrical hazards.
- Wire rope lifelines must not contact sharp edges or abrasive surfaces.

**INSPECTION-**  
 Before each use inspect entire davit, including attached Dynevac, according to User Instructions. Look for damage, alteration, missing or broken parts, excessive wear and corrosion. Inspect ladder and ladder stand-offs for cracks, breaks, loose or missing parts. **Never use davit if any of these conditions exist.** Do not attempt field repairs of davit assembly. Formally inspect by a competent person other than the user at least every six months. Note successful completion of formal inspection by punching date on grid. If davit fails inspection, remove from use and label "UNUSABLE" until repaired or destroyed.

**CAUTION**

**FORMAL INSPECTION GRID**

	J	F	M	A	M	J	J	A	S	O	N	D
96												
97												
98												
99												
00												

PUNCH GRID ON DATE OF FIRST USE

<b>DATE OF MANUFACTURE</b>				
YR	1996	1997	1998	1999
MTH	JAN	FEB	MAR	APR
	MAY	JUN	JUL	AUG
	SEP	OCT	NOV	DEC

Rose Manufacturing Co.,  
 2250 S. Tejon St., Englewood,  
 CO 80110-1000,  
 1-800-722-1231 P/N 623050

## 11.0 INSPECTION BEFORE EACH USE

- 11.1 INSPECTION FREQUENCY:** The vertical mount davit system must be inspected by the user before each use and, additionally, by a competent person other than the user at intervals of no more than six months. The competent person inspection is referred to as Formal Inspection. See section 12 for Formal Inspection procedures.

### CAUTION

If the vertical mount davit system has been subjected to fall arrest or impact forces, it must be immediately removed from service and marked as "UNUSABLE" until evaluated and disposition made by a competent person within the user's organization.

- 11.2 PROCEDURE FOR INSPECTION BEFORE EACH USE:** Perform the following steps in sequence. If in doubt about any inspection point, consult MSA or a competent person who is qualified to perform Formal Inspection as set forth in section 12.
- 11.2.1 LADDER ANCHORAGE:** Visually inspect the ladder for cracks, breaks, deformation, alteration and missing or damaged parts. Verify that the standoff brackets are secured to the structure according to the manufacturer's specifications. Inspect the ladder rungs and side rails for missing or cracked welds, deformation, cracks or breaks, corrosion and altered or damaged parts. Do not use if inspection reveals an unsafe condition.
- 11.2.2 DAVIT MOUNTING RECEPTACLE:** Inspect for damaged welds by visually examining each weld area for signs of cracking. Visually examine the entire assembly for deformed, altered or damaged parts. Inspect labels to verify that they are present and legible. Verify that there no obstructions which would prevent installation of the vertical davit assembly. Verify that the mounting receptacle is mounted correctly on the ladder anchorage and that all nuts are present and tightened to 50 pound foot (67 N-m). Do not use if inspection reveals an unsafe condition.
- 11.2.3 DAVIT MOUNTING RECEPTACLE:** Visually inspect the entire length of the davit tube for cracks, breaks, corrosion or permanent deformation. Inspect the welds also for signs of cracking. Verify labels are present and legible. Inspect the D-ring anchorage connector for cracks, breaks, corrosion, alteration and missing or damaged parts. If the davit is installed in the mounting receptacle, verify that the 1/2 inch dia. Grade 5 bolt and lock-nut are present and properly secured. Do not use if inspection reveals an unsafe condition.
- 11.2.4 DYNEVAC MOUNTING BRACKETS:** Visually inspect the aluminum casting for signs of damage, including cracks, breaks or permanent deformation. Verify that four (4) 3/8 inch dia. Grade 5 bolts and lock-nuts are present and the bolts are tightened to 31 pound foot (42 N-m). Verify the hair-pin cotter is present and that the label is present and legible. Do not use if inspection reveals an unsafe condition.

### CAUTION

Formally inspect all components by a competent person other than the user at intervals of no more than six months. See section 12.0 for procedures.

If inspection reveals any defect, remove the device from service and label "UNUSABLE" until it is repaired or destroyed. The vertical mount davit system are not field repairable. Never attempt the field repairs. Return the defective part(s) to MSA, or to persons authorized in writing by MSA for repair.

## 12.0 FORMAL INSPECTION LOG

- 12.1 FORMAL INSPECTION FREQUENCY:** The vertical mount davit system must be formally inspected by a competent person other than the user at intervals of no more than six months. (The qualifications of a competent person are established by OSHA.) If the product is exposed to severe working conditions, more frequent formal inspections may be required. The frequency of inspection by a competent person should be established by the user's organization based on such factors as the nature and severity of workplace conditions, modes of use, and exposure time of the equipment. The competent person should perform a methodical and thorough visual and tactile inspection by following the inspection procedure in section 12.3. The inspection results should be recorded in the Formal Inspection Log and retained for reference. The user should never record this data; however, the user should check it before each use to be sure a Formal Inspection has been performed within the last six months.
- 12.2 CONTROL OF EQUIPMENT:** The user's organization should establish and enforce a policy and procedure whereby any

vertical mount davit system that is found to be defective, damaged, or in need of maintenance be immediately removed from use, marked as "UNUSABLE" and immediately thereafter submitted to custody of the competent person responsible for Formal Inspection. This has the benefits that: 1) defective equipment is secured from further use until proper action is taken; 2) uniform standards are applied for determining whether the equipment is acceptable or not acceptable for further use; 3) uniform methods of cleaning and other maintenance are applied; and 4) there is a central point for evaluation of conditions that may be recurring and require preventive measures such as coordination with the equipment manufacturer, selection of alternate equipment, additional training of equipment users, or changes to the workplace conditions.

**12.3 FORMAL INSPECTION PROCEDURE:** The Formal Inspection Procedure is similar to the user's inspection before each use described in section 11. However, it differs in three important respects, namely: 1) it is performed by a competent person other than the user who is trained and authorized to perform Formal Inspection for the user's organization; 2) it is more detailed and is methodically recorded on a Formal Inspection Log that is kept on file for future reference; and 3) it results in final disposition of the equipment as either "acceptable" (indicated by the formal inspector recording the current month/year in the Formal Inspection Grid on one of the product labels), or as "not acceptable" followed by destruction of the product. The described detailed inspection record keeping is needed in order to trace detected defects to their causes. A simplified alternative procedure is also explained below.

There are three forms that are important to the Formal Inspection Procedure. They are the Formal Inspection Diagram ("DIAGRAM"), the Formal Inspection Log ("LOG"), and the Formal Inspection Checklist and Codes ("CHECKLIST"). These forms relate and refer to each other so it is necessary to understand their purposes and uses before discussing the inspection procedure.

**12.3.1 DIAGRAM:** This is a drawing of the vertical mount davit system. It has numbered callouts of the parts. The numbers called out in the DIAGRAM correspond to those shown on the column titled "INSP. POINT" (inspection point) on the LOG.

**12.3.2 LOG:** This is the form to be used to record observations made during the Formal Inspection. The Model No., Serial No. and Date Made are recorded by the inspector from the label set. The formal inspector's name and the inspection date are entered by the inspector. The "Disposition" entry is the last entry made on this form after all observations have been recorded. The entry is either "Acceptable" ("PASS") or "Not Acceptable" ("FAIL"). The columns on the LOG are as follows:

**INSP. POINT** - Inspection point. The vertical mount davit system part designated in the callouts on the DIAGRAM.

**DESCRIPTION** - Name of the vertical mount davit system inspection point. There are two broad categories of inspection points, namely, metallic parts, and plastic parts. There are subcategories under these two main categories.

**QTY/VMDS** - Quantity per vertical mount davit system. This is the number of inspection points on each vertical mount davit system which must be inspected.

**COND.** - Condition. The condition of the vertical mount davit system part is indicated here by entry of the appropriate Condition Code shown on the CHECKLIST (e.g. M0, etc.). Alternatively, the inspector may simply enter "FAIL" if a defective condition exists and make no entry if no defect exists.

**OVERALL ASSESS.** - Overall assessment. The inspector's evaluation of the overall acceptability or non-acceptability of the part category (i.e. metallic, plastic). The appropriate Overall Assessment Code defined on the CHECKLIST is entered here (e.g. MA, PN). Alternatively, the inspector may simply enter "FAIL" if a defective condition exists and make no entry if no defect exists.

**COMMENTS** - Indicate pertinent inspector observations here.

**12.3.3 CHECKLIST AND CODES:** This is a table which categorizes the different types of vertical mount davit system parts into broad categories (e.g. metallic, plastic). For each of these categories that are applicable to a specific product, the formal inspector checks the vertical mount davit system parts for each of the associated conditions (e.g. cracks, deformation, wear, etc.). The codes for the detected conditions are entered in the Condition column on the LOG (e.g. M0, etc.). Overall assessment codes are given, along with the criteria for assigning them, so the inspector can decide if the vertical mount davit system is acceptable or not acceptable for further use (e.g. MA, PN). Alternatively, instead of using these codes, the inspector may simply enter "FAIL" if a defective condition exists and make no entry if no defect exists.

**12.3.4 FORMAL INSPECTION PROCEDURAL STEPS:**

**Step 1:** Record on the LOG the Model No., Serial No. and Date Made information shown on the product label set. Record the inspector's name and inspection date.

**Step 2:** Arrange the vertical mount davit system so the parts to be inspected are readily visible.

- Step 3:** Starting with the metallic category of parts shown on the LOG, inspect each part (inspection point) one at a time. Refer to the DIAGRAM for identification of each inspection point. Each part must be inspected for the possible presence of the conditions shown on the CHECKLIST. Enter in the Condition column on the LOG the proper Condition Code (listed on the CHECKLIST) or "FAIL" if a defect exists. If there is any question whether the product has materially changed since the last Formal Inspection, retrieve and review the prior Formal Inspection records for the specific product.
- Step 4:** Repeat Steps 2 and 3 for the plastic categories of part types.
- Step 5:** Determine whether the part (inspection point) is acceptable or not acceptable. If an inspection point has a defective condition, enter in the Overall Assessment column of the LOG the proper code taken from the CHECKLIST (e.g. WN, SN, MN, PN) or simply "FAIL."
- Step 6:** Determine disposition of the vertical mount davit system. If in step 5 it has been determined that the vertical mount davit system is not acceptable, enter "N" or "FAIL" in the Disposition space on the LOG. In addition, a notation should be made in this space as to whether the vertical mount davit system is to be destroyed, returned to manufacturer/distributor, etc.
- Step 7:** If in step 5 it has been determined that the vertical mount davit system is acceptable for further use, enter "A" or "PASS" in the Disposition space on the LOG.
- Step 8:** File the LOG for future reference.

**12.4 FORMAL INSPECTION CHECKLIST AND CODES**

TYPE OF PART INSPECTED	CONDITION	COND. CODE	OVERALL ASSESSMENT CODE	LEGEND
Metallic	Deformed/fractured Corroded/deep pits Missing/loose Heat exposure Chemical exposure Burrs/sharp edges Cuts/deep nicks Malfunction Other No visible change	M1 M2 M3 M4 M5 M6 M7 M8 M9 M0	MA - (Metallic acceptable)  MN - (Metallic not acceptable)	<b>Disposition:</b> A - (Acceptable) N - (Not acceptable) Enter "A" (or "PASS") or "N" (or "FAIL") in Disposition blank on Formal Inspection Log.
Plastic	Cut/broken/deformed Wear damage Missing/loose Burns/heat exposure Chemical exposure Other No visible change	P1 P2 P3 P4 P5 P6 P0	PA - (Plastic acceptable)  PN - (Plastic not acceptable)	<b>Criteria for disposition of "N" (Not acceptable):</b>  If there is one or more Overall Assessment Code of "N" type (e.g. WN, SN, MN, PN).

## 12.5 FORMAL INSPECTION LOG FOR MSA VERTICAL MOUNT DAVIT SYSTEM, EXAMPLE

## FORMAL INSPECTION LOG FOR MSA DAVIT MOUNTING RECEPTACLE

Model No.: 506667 Inspector: J. W. Doe  
 Serial No.: D01001K Inspection Date: 12/15/96  
 Date Made: 6/96 Disposition: N - See item 2, Return to MSA.

INSP. POINT	DESCRIPTION	QTY/ VMDS	COND. (a)	OVERALL ASSESS.(a)	COMMENTS
<b>METALLIC PARTS</b>					
1	Steel Tube	1	<i>M0</i>	<i>MA</i>	
2	Threaded Rod	6	<i>M1</i>	<i>MN</i>	<i>Weld Cracked</i>
3	Clamp	3	<i>M0</i>	<i>MA</i>	
4	Split Washer	6	<i>M0</i>	<i>MA</i>	
5	Nut, 1/2" -13UNC	6	<i>M0</i>	<i>MA</i>	
6	Bolt, 1/2" dia.	1	<i>M0</i>	<i>MA</i>	
7	Lock Nut, 1/2"-13UNC	1	<i>M0</i>	<i>MA</i>	
<b>PLASTIC PARTS</b>					
8	Labels	2	<i>P0</i>	<i>PA</i>	

## FORMAL INSPECTION LOG FOR VERTICAL DAVIT ASSEMBLY

Model No.: 506668 Inspector: J. W. Doe  
 Serial No.: D01001L Inspection Date: 12/15/96  
 Date Made: 6/96 Disposition: N - See item 1, Return to MSA.

INSP. POINT	DESCRIPTION	QTY/ VMDS	COND. (a)	OVERALL ASSESS.(a)	COMMENTS
<b>METALLIC PARTS</b>					
9	Steel Tube	1	<i>M2</i>	<i>MN</i>	<i>Severe corrosion</i>
10	Mounting Plate	2	<i>M0</i>	<i>MA</i>	
11	D-ring	1	<i>M0</i>	<i>MA</i>	
12	D-ring Plate	1	<i>M0</i>	<i>MA</i>	
13	Bolt	2	<i>M0</i>	<i>MA</i>	
<b>PLASTIC PARTS</b>					
14	Label	2	<i>P0</i>	<i>PA</i>	

- (a) Optional simplified PASS/FAIL inspection format: Whenever an acceptable condition is found, the entry in the COND. and OVERALL ASSESS. columns may be left blank. Whenever a defective condition is found, enter "FAIL." The inspection may end upon detection of a single defective condition.
- (b) Blank copies of this LOG, with associated CHECKLIST and DIAGRAM, are available from MSA. Call Toll Free (800) 672-2222.



12.5 FORMAL INSPECTION LOG FOR MSA VERTICAL MOUNT DAVIT SYSTEM

FORMAL INSPECTION LOG FOR MSA DAVIT MOUNTING RECEPTACLE

Model No.: \_\_\_\_\_ Inspector: \_\_\_\_\_  
 Serial No.: \_\_\_\_\_ Inspection Date: \_\_\_\_\_  
 Date Made: \_\_\_\_\_ Disposition: \_\_\_\_\_

INSP. POINT	DESCRIPTION	QTY/ VMDS	COND. (a)	OVERALL ASSESS.(a)	COMMENTS
<b>METALLIC PARTS</b>					
1	Steel Tube	1			
2	Threaded Rod	6			
3	Clamp	3			
4	Split Washer	6			
5	Nut, 1/2" -13UNC	6			
6	Bolt, 1/2" dia.	1			
7	Lock Nut, 1/2"-13UNC	1			
<b>PLASTIC PARTS</b>					
8	Labels	2			

FORMAL INSPECTION LOG FOR VERTICAL DAVIT ASSEMBLY

Model No.: \_\_\_\_\_ Inspector: \_\_\_\_\_  
 Serial No.: \_\_\_\_\_ Inspection Date: \_\_\_\_\_  
 Date Made: \_\_\_\_\_ Disposition: \_\_\_\_\_

INSP. POINT	DESCRIPTION	QTY/ VMDS	COND. (a)	OVERALL ASSESS.(a)	COMMENTS
<b>METALLIC PARTS</b>					
9	Steel Tube	1			
10	Mounting Plate	2			
11	D-ring	1			
12	D-ring Plate	1			
13	Bolt	2			
<b>PLASTIC PARTS</b>					
14	Label	2			

- (a) Optional simplified PASS/FAIL inspection format: Whenever an acceptable condition is found, the entry in the COND. and OVERALL ASSESS. columns may be left blank. Whenever a defective condition is found, enter "FAIL." The inspection may end upon detection of a single defective condition.
- (b) Blank copies of this LOG, with associated CHECKLIST and DIAGRAM, are available from MSA. Call Toll Free (800) 672-2222.

12.6 FORMAL INSPECTION DIAGRAM

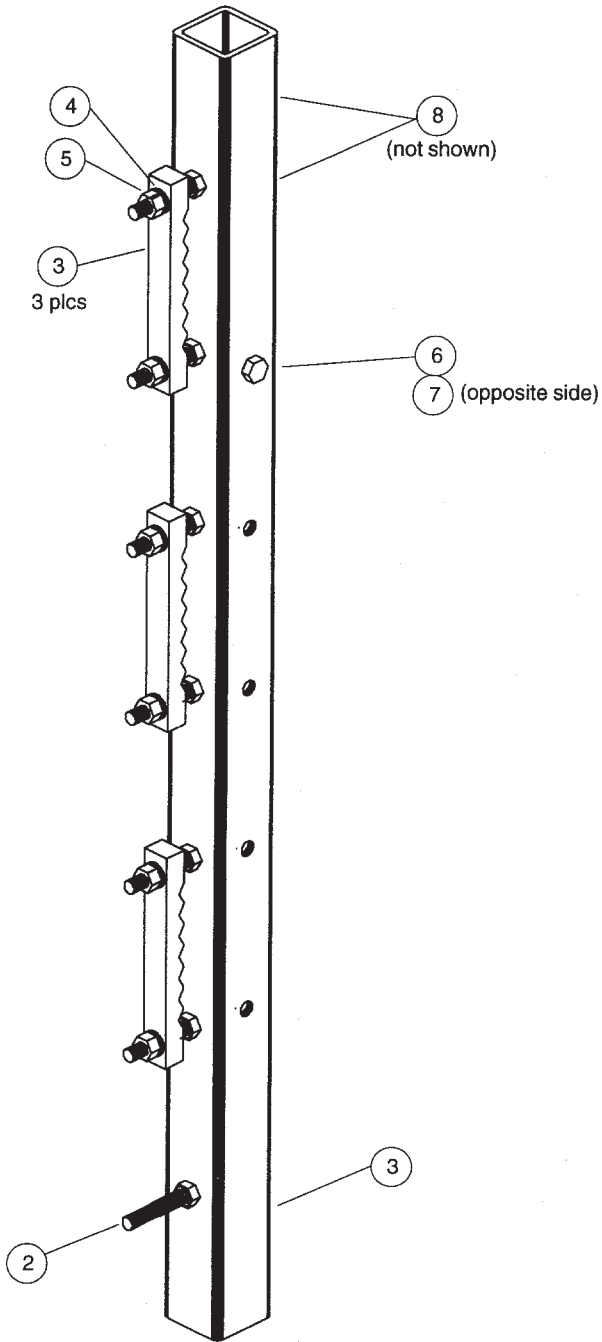

DAVIT MOUNTING RECEPTACLE  
(P/N 506667)

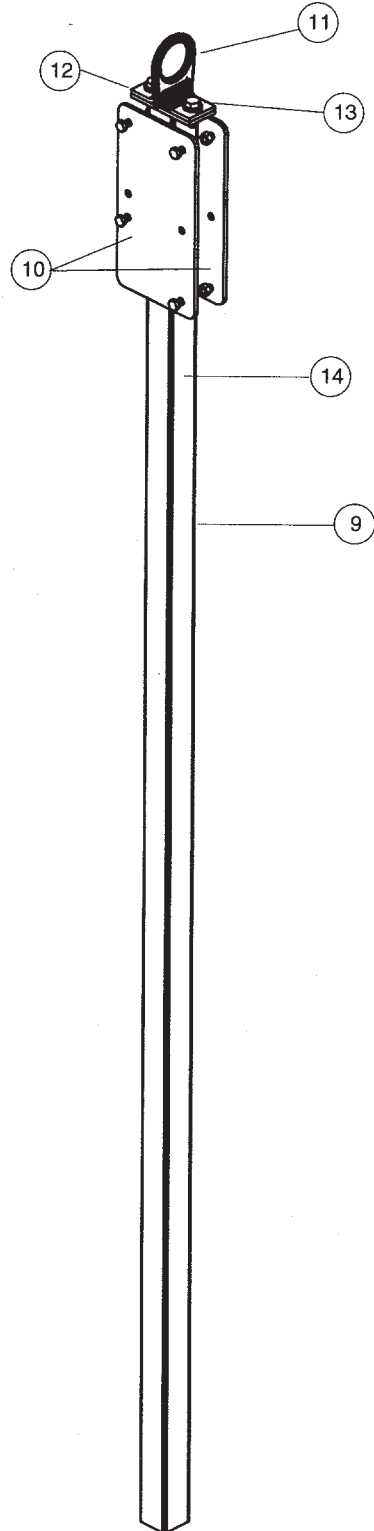

VERTICAL DAVIT ASSEMBLY  
(P/N 506668)



**WARRANTY**

**Express Warranty** – MSA warrants that the product furnished is free from mechanical defects or faulty workmanship for a period of one (1) year from first use or eighteen (18) months from date of shipment, whichever occurs first, provided it is maintained and used in accordance with MSA's instructions and/or recommendations. Replacement parts and repairs are warranted for ninety (90) days from the date of repair of the product or sale of the replacement part, whichever occurs first. MSA shall be released from all obligations under this warranty in the event repairs or modifications are made by persons other than its own authorized service personnel or if the warranty claim results from misuse of the product. No agent, employee or representative of MSA may bind MSA to any affirmation, representation or modification of the warranty concerning the goods sold under this contract. MSA makes no warranty concerning components or accessories not manufactured by MSA, but will pass on to the Purchaser all warranties of manufacturers of such components. THIS WARRANTY IS IN LIEU OF ALL OTHER WARRANTIES, EXPRESS, IMPLIED OR STATUTORY, AND IS STRICTLY LIMITED TO THE TERMS HEREOF. MSA SPECIFICALLY DISCLAIMS ANY WARRANTY OF MERCHANTABILITY OR FITNESS FOR A PARTICULAR PURPOSE.

**Exclusive Remedy** - It is expressly agreed that the Purchaser's sole and exclusive remedy for breach of the above warranty, for any tortious conduct of MSA, or for any other cause of action, shall be the repair and/or replacement, at MSA's option, of any equipment or parts thereof, that after examination by MSA are proven to be defective. Replacement equipment and/or parts will be provided at no cost to the Purchaser, F.O.B. Purchaser's named place of destination. Failure of MSA to successfully repair any nonconforming product shall not cause the remedy established hereby to fail of its essential purpose.

**Exclusion of Consequential Damages** - Purchaser specifically understands and agrees that under no circumstances will MSA be liable to Purchaser for economic, special, incidental, or consequential damages or losses of any kind whatsoever, including but not limited to, loss of anticipated profits and any other loss caused by reason of the non-operation of the goods. This exclusion is applicable to claims for breach of warranty, tortious conduct or any other cause of action against MSA.

**For additional information, please contact the Customer Service Department at 1-800-MSA-2222 (1-800-672-2222).**

MSA CORPORATE HEADQUARTERS ■ P.O. BOX 426  
PITTSBURGH ■ PA ■ 15230 ■ USA  
TEL. 1-800-672-2222 ■ FAX 1-800-967-0398

**Dyna Brake®, Dyna-Glide™, Dynescape™, Dyna-Lock®, Dynevac® and Pullover™ Harness are trademarks of MSA. U.S. patents and foreign patents cover various aspects of this product.**