



GENERAL MONITORS

Model TA402A

Zero Two Series Trip Amplifier

Module for Flame Detection

Applications



The information and technical data disclosed in this document may be used and disseminated only for the purposes and to the extent specifically authorized in writing by General Monitors.

Instruction Manual

11/03

General Monitors reserves the right to change published specifications and designs without prior notice.

Part No
Revision

MANTA402A
E/11-03



Warranty Statement

General Monitors warrants the *Model TA402A* to be free from defects in workmanship or material under normal use and service within two (2) years from the date of shipment. General Monitors will repair or replace without charge any such equipment found to be defective during the warranty period. Full determination of the nature of, and responsibility for, defective or damaged equipment will be made by General Monitors' personnel. Defective or damaged equipment must be shipped prepaid to General Monitors' plant or the representative from which shipment was made. In all cases this warranty is limited to the cost of the equipment supplied by General Monitors. The customer will assume all liability for the misuse of this equipment by its employees or other personnel. All warranties are contingent upon proper use in the application for which the product was intended and do not cover products which have been modified or repaired without General Monitors' approval or which have been subjected to neglect, accident, improper installation or application, or on which the original identification marks have been removed or altered. Except for the express warranty stated above, General Monitors disclaims all warranties with regard to the products sold, including all implied warranties of merchantability and fitness and the express warranties stated herein are in lieu of all obligations or liabilities on the part of General Monitors for damages including, but not limited to, consequential damages arising out of/or in connection with the use or performance of the product.

Warnings

- All Zero Two Series Modules contain components which can be damaged by static electricity. Special care must be taken when wiring the system to ensure that only the connection points are touched.
- Unitized Flame Detectors designed by General Monitors will work with the Model TA402A. Any attempt to use a Field Device that has not been designed and approved by General Monitors will void the warranty.
- **SAFETY WARNING:**
Installation and Maintenance must be carried out by suitably skilled and competent personnel only.
- Full backwards compatibility can be specified at the time of order. If this configuration is specified, the rear terminal output designation will be identical to the previous generation of Zero Two Series Modules.
- This generation of product can be distinguished from the previous generation by the lack of a door on the front panel. Adjustments are not necessary on the current generation of this product.



	Page Number
Warranty	i
Warnings	i
Illustrations	iii
1 Introduction	
1.1 General Description	1
1.2 Features & Benefits	1
1.3 Applications	2
2 Specifications	
2.1 System Specifications	3
2.2 Mechanical Specifications	3
2.3 Electrical Specifications	3
2.4 Environmental Specifications	4
2.5 Engineering Specifications	4
3 Installation	
3.1 Upon Receipt of Equipment	7
3.2 Control Module Installation	7
3.3 Rear Terminal Connections	7
3.4 Detector Location Considerations	12
3.6 Applying Power	12
4 Operation	
4.1 General Maintenance	13
4.2 Electrical Inputs	13
4.3 Electrical Outputs	13
4.4 Accepting Alarm Conditions.....	14
4.5 Resetting Latched Alarm	15
4.6 CAL/INH Open Collector	15
4.7 Card Test Feature	15
4.8 Fault Diagnostics	16
5 User Interfaces	
5.1 Types of User Interfaces	17
5.2 Setup Check & Setup Modes	17
5.3 Inhibit Mode Description	24
6 Sensor Assembly/Accessories	
6.1 Flame Detectors	25
6.2 UV Phototube	27
6.3 Pyroelectric Device	27
6.4 Thermopile	27
6.5 Test Lamps	28



	Page Number
7 Appendix	
A Glossary of Terms	30
B Engineering & Technical Drawings	32
C Ordering Information	40
D Zero Two Series Modules	41
8 Index	42

Illustrations

Figure 1	Isometric View of the Model TA402A	1
Figure 2	Control Module Coding Strip	7
Figure 3	Wire Strip Length.....	8
Figure 4	Rear Terminal Designations.....	8
Figure 5	Relay Protection Circuit for AC Loads	9
Figure 6	Relay Protection Circuit for DC Loads	10
Figure 7	Detector / Controller Connections	10
Figure 8	Typical External Circuits for Open Collectors	11
Figure 9	Card Test Switch Wiring	11
Figure 10	Analog Signal Connections.....	11
Figure 11	Power Connections - Rear Chassis	12
Figure 12	Front Panel Display.....	17
Figure 13	Entering the Setup & Setup Check Modes	19
Figure 14	Entering the Password	19
Figure 15	Entering the Inhibit Mode	20
Figure 16	A2 Energized/De-Energized Alarm Option	20
Figure 17	A2 Latching/Non-Latching Alarm Option	20
Figure 18	A2 Alarm Time Delay Option	21
Figure 19	A1 Energized/De-Energized Alarm Option	21
Figure 20	A1 Latching/Non-Latching Alarm Option	21
Figure 21	Fault / Inhibit Option	22
Figure 22	Entering Card Test Options	22
Figure 23	Alarm Output Option during a Card Test, Ac / nA	23
Figure 24	Password Enabled/Disabled Option	23
Figure 25	Entering a new Password	23
Figure 26	FL3000 Picture	25
Figure 27	FL3001 Picture	25
Figure 28	FL3002 Picture	25
Figure 29	FL3100 Picture	26
Figure 30	FL3101 Picture	26
Figure 31	FL3102 Picture	26
Figure 32	Energy Spectrum	27
Figure 33	Schematic Diagram - Detector Input Circuit	32
Figure 34 & 35	Schematic Diagram - Control Board	33 & 34
Figure 36	Schematic Diagram - Display Board	35
Figure 37	Circuit Card Assembly - Control Board	36
Figure 38	Circuit Card Assembly - Display Board	37
Figure 39	Outline & Terminal Connections	38
Figure 40	Final Assembly Drawing	39



This chapter provides a brief description of the Model TA402A, its features & benefits and a list of some of its applications. More detailed information on the features and benefits listed in section 1.2 will be presented in later chapters.

1.1 General Description

The General Monitors Model TA402A (see figure 1) is a single channel Flame Detection Trip Amplifier designed for use in Zero Two Series Gas and Flame Detection Systems. This Module connects to the wires from a field mounted General Monitors Flame Detector, which monitors the presence of radiation emitted from fires.

The Model TA402A is electrically and physically compatible with the other gas detection and system modules in the Zero Two Series. It is distinguished from the other modules by its red border and "TA402A" in the upper right corner of the front panel. The Model TA402A is designed for use in non-hazardous environments.

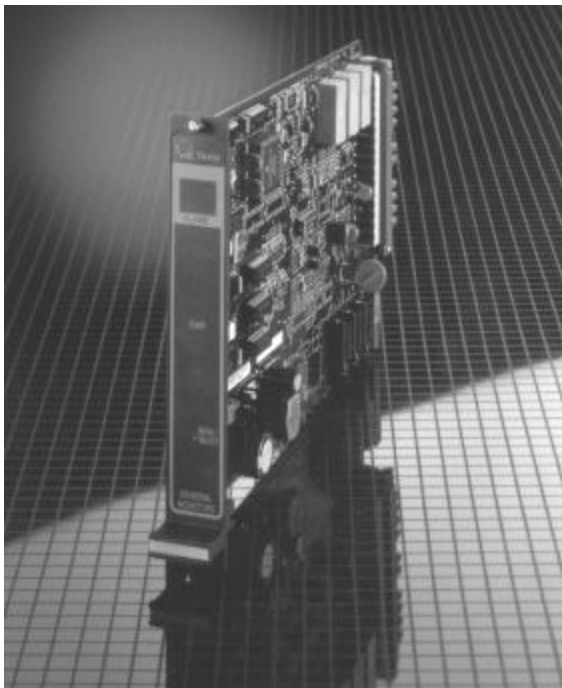

Figure 1

1.2 Features & Benefits

Microprocessor Based Electronics: monitors fault conditions, sensor inputs and provides outputs in the form of display codes, analog signal, relay contact and open collector activations.

Setup Mode: allows the user to set parameters such as alarm output options, test options, etc. These parameters are viewed on the display during the Setup Mode.

Password Option: prevents unauthorized alteration of the setup parameters (can be disabled).

Setup Check Mode: allows the user to view the parameters that have been set by the factory and/or an operator.

LED Test: tests the integrity of each display LED and each segment of the digital display on the front panel.

Card Test: tests the functionality of the card through the microprocessor ramping up the signal to the alarm level for the time delay.

Live Insertion/Removal: allows the user to insert or remove a module while power is applied to the system without damage to any of the components in the system.



1.3 Applications

The General Monitors Model TA402A is a Trip Amplifier designed for Zero Two Series Flame Detection Applications. Below is a partial list of applications:

- Refineries
- Drilling platforms and rigs
- Gas and oil production platforms
- Gas collection facilities
- LPG/LNG processing and storage
- Gas turbines
- Solvent vapors
- Chemical & petrochemical plants
- Paint spray booths
- Aircraft hangars



This chapter provides detailed specifications for the Model TA402A Zero Two Series Trip Amplifier Module. System, mechanical, electrical and environmental specifications present the Model TA402A in technical terms. The engineering specification provides a written specification that can be inserted into another written specification by architects and engineers.

2.1 System Specifications

Application:

Flame Detection.

Detector Type:

General Monitors' FL3000 and FL3100 Flame Detectors.

Measuring Ranges (flame detectors):

UV Wavelength . 185 to 260nm
IR Wavelength... 4.3um (centerline)

Typical response times for TA402A System:

with FL3000, FL3100	2 to 5 sec
with FL3001, FL3101	< 1 sec
with FL3002, FL3102	2 to 5 sec

Test Features:

Card - Functionality & Alarm Ramp
LED - Integrity of LED's & Display

Front Panel Indicators:

DISPLAY - 2 x 7 Segments
A2 - Time Delayed Alarm
A1 - Immediate Warning
READY - Normal Operation
SETUP - Display / Change Parameters

Modes of Operation:

Setup, Setup Check, Inhibit & Normal

Approvals:

The Model TA402A is CSA certified.

Warranty:

Two Years

2.2 Mechanical Specifications

Weight: 11.2 oz. (318 grams)

Length: 9.9 inches (251 mm)

Height: 6.825 inches (173 mm)

Width: 1.0 inches (25 mm)

2.3 Electrical Specifications

Input Power Requirement:

20 to 35Vdc @ 375mA max. (24Vdc, 9W nominal with field device).

Electrical Classification:

General Monitor's FL3000 and FL3100 Series Flame Detectors are rated for use in Class I, Division 1, Groups B, C & D; Class II, Groups E, F & G and Class III. The Model TA402A is designed for use in non-hazardous environments.

Relay Contact Rating:

4A @ 250Vac, 3A @ 30Vdc resistive max. DPDT for A1 & A2, SPDT for Fault.

Open Collector Rating:

100mA @ 35 Vdc for A1, A2, Fault, UA, FUA, CAL-OC, LA1 & LA2.

Cable Parameters:

Recommended three wire shielded, maximum cable lengths allowable between module and the Field Device with 24Vdc nominal at the detector:

AWG	Feet	Meters
14	4500	1372
16	2250	685
18	1600	488
20	1100	335
22	750	228

**Cable Parameters** (continued)

The maximum allowable cable lengths between the analog output connections on the control module with a remote device in series (maximum loop resistance of 300 Ohms between Analog Signal & Common at the field device):

AWG	Feet	Meters
14	9000	2740
16	5200	1585
18	3800	1160
20	2400	730
22	1600	488

2.4 Environmental Specifications**Operating Temperature Range:**

Field -40°F to +140°F
 Device -40°C to +60°C

TA402A 0°F to +150°F
 -18°C to +66°C

Storage Temperature Range:

Field -40°F to +167°F
 Device -40°C to +70°C

TA402A -40°F to +150°F
 -40°C to +66°C

Operating Humidity Range:

5% to 100% Relative Humidity,
 non-condensing

2.5 Engineering Specifications

Zero Two System - Each system shall utilize modules capable of monitoring gas sensing elements or a 0 to 21.7mA analog signal from gas or flame detection transmitters. The system chassis shall be available in 4, 8 and 16 channels. Each chassis shall contain a bus for the following independent signals: A1 Warn, A2 Alarm, Fault Alarm, Master Reset, Master Accept, Unaccept, CAL, +24Vdc and System Common. Module signals shall be capable of being bussed from one chassis to another, so that up to 100 modules can comprise a single system. The gas and flame detection modules shall be electrically and physically compatible and capable of being used in the same chassis to form combined fire and gas detection systems. The system shall consist of Zero Two Series component modules as manufactured by General Monitors, Lake Forest, California, U.S.A. or General Monitors, Galway, Ireland.

TA402A Trip Amplifier Module - The trip amplifier module, with a General Monitors' flame detector, shall meet the design requirements of CSA and Factory Mutual. The trip amplifier module shall have an interface panel, providing a mode/select switch and the following indications: 2 discrete alarm threshold level indicators, a fault or malfunction indicator, a ready indicator, a setup mode indicator and a 2 digit digital display. All Warn and Alarm parameters and user options shall be software selectable. A functional card test and a front panel LED test shall be switch capable without interrupting normal on-line services. The trip amplifier module shall be capable of insertion and removal during power on conditions without damage to any component module in the system.



Engineering Specification *(continued)*

The trip amplifier module will generate display codes associated with fault conditions whenever a fault or malfunction occurs. A mode/select switch shall provide the operator front panel access to a setup check mode, a setup mode and an inhibit mode. The trip amplifier module shall have a password protected setup routine capable of having the password disabled.



This page left blank intentionally



This chapter discusses what to do when a Model TA402A is received, the terminal connections & designations, field device location considerations and what to be aware of when applying power.

3.1 Upon Receipt of Equipment

All equipment shipped by General Monitors is packaged in shock absorbing containers which provide considerable protection against physical damage. The contents should be carefully removed and checked against the packing slip. If any damage has occurred or if there is any discrepancy in the order, notify General Monitors as soon as possible. All subsequent correspondence with General Monitors must specify the equipment part and serial numbers.

Each Model TA402A is completely checked at the factory, however, a complete check-out is necessary upon initial installation and start up to ensure system integrity.

3.2 Control Module Installation

A rack or panel mounted chassis will be required when installing any Zero Two Series Module. These chassis should be mounted in non-hazardous, weather protected locations and should be subjected to minimal shock and vibrations. The rack and panel mounted chassis are available in 4, 8, and 16 channel sizes. Multiple 16 channel chassis may be connected to each other to form larger systems.

In installations where two or more module types are to be mixed in the same chassis, ensure that the individual coding strips match the channel application. The coding

strips are pre-configured at the factory and the male portion is already on each module. The female portion, if unmounted, must be fastened into position on the mounting strip of the desired chassis channel so as to mate with its counterpart on the module (see figure 2 below).

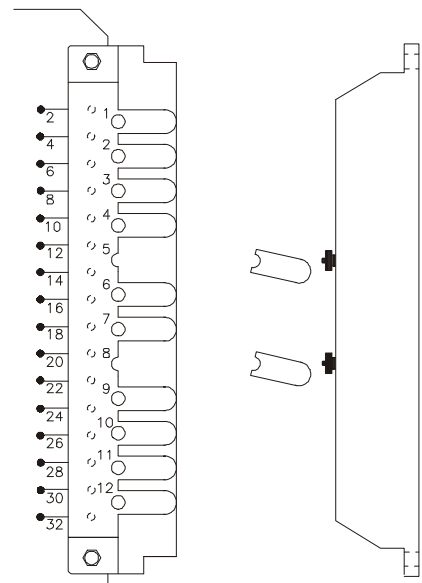

Figure 2

Zero Two series modules require air circulation to avoid excessive heat build-up. If chassis are stacked vertically within an enclosure, forced air circulation may be required. The Trip Amplifier Modules are, to a great extent, immune to electromagnetic interference (EMI). However, they should not be mounted in close proximity to radio transmitters or similar equipment.

3.3 Rear Terminal Connections

All wire connections to the Model TA402A are made to the terminal block located at the rear of the chassis. The terminal block accepts 16 AWG to 20 AWG, stranded or solid core wire.



Rear Terminal Connections (continued)

14 AWG wire may be used if it is properly stripped according to figure 3.

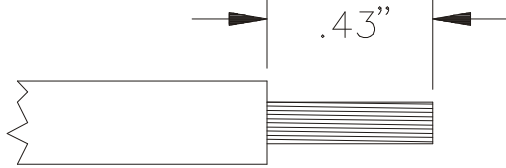

Strip Length
Figure 3

Contact with PC Board components should be avoided in order to prevent damage by static electricity.

To connect wires to the terminal block on the Model TA402A, loosen the desired screw, insert the stripped end of the wire and tighten.

For the rear terminal designations refer to figure 4 below:

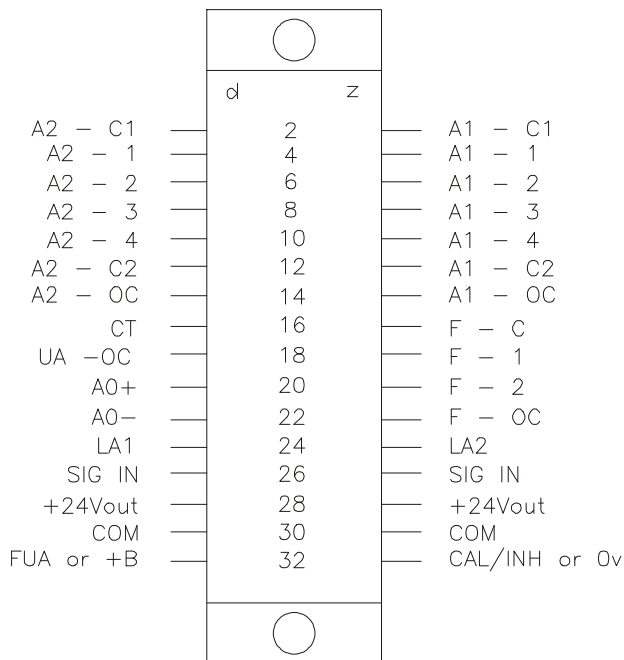

Figure 4

A2 Time Delayed Alarm

The terminal designations for the A2 Time Delayed Alarm outputs are:

<u>Label</u>	<u>Term</u>	<u>Description</u>
A2-C1	2d	Relay Common (1&2)
A2-1	4d	Relay Contact
A2-2	6d	Relay Contact
A2-3	8d	Relay Contact
A2-4	10d	Relay Contact
A2-C2	12d	Relay Common (3 & 4)
A2-OC	14d	Open Collector (OC)
LA2	24z	OC Logic for A2 LED

The A2 Time Delayed Alarm outputs are DPDT relays, 1 open collector output (A2-OC) that follows the logic of the relays and 1 open collector output (LA2) that follows the blinking pattern of the front panel LED. The A2-C1 designation is common for A2-1 & A2-2. The A2-C2 designation is common for A2-3 & A2-4. The normally open (NO) and normally closed (NC) contacts depend on a user selectable option (see chapter 5).

The table below refers to the proper open and closed A2 Time Delayed Alarm relay contacts while the unit is on power:

User Selected Relay State	Normally Open	Normally Closed
Normally Energized	A2-C1 & A2-1, A2-C2 & A2-4	A2-C1 & A2-2, A2-C2 & A2-3
Normally De-Energized	A2-C1 & A2-2, A2-C2 & A2-3	A2-C1 & A2-1, A2-C2 & A2-4



Rear Terminal Connections (continued)

A1 Immediate Warn

The terminal designations for the A1 Immediate Warn outputs are:

Label	Term	Description
A1-C1	2z	Relay Common (1 & 2)
A1-1	4z	Relay Contact
A1-2	6z	Relay Contact
A1-3	8z	Relay Contact
A1-4	10z	Relay Contact
A1-C2	12z	Relay Common (3 & 4)
A1-OC	14z	Open Collector (OC)
LA1	24d	OC Logic for A1 LED

The A1 Immediate Warn outputs are DPDT relays, 1 open collector output (A1-OC) that follows the logic of the relays and 1 open collector output (LA1) that follows the blinking pattern of the front panel LED. The A1-C1 designation is common for A1-1 & A1-2. The A1-C2 designation is common for A1-3 & A1-4. The normally open (NO) and normally closed (NC) contacts depend on a user selectable option (see chapter 5).

The table below refers to the proper open and closed A1 Immediate Warn relay contacts while the unit is on power:

User Selected Relay State	Normally Open	Normally Closed
Normally Energized	A1-C1 & A1-1, A1-C2 & A1-4	A1-C1 & A1-2, A1-C2 & A1-3
Normally De-Energized	A1-C1 & A1-2, A1-C2 & A1-3	A1-C1 & A1-1, A1-C2 & A1-4

Fault Alarm

The terminal designations for the Fault outputs are:

Label	Term	Description
F-C	16z	Relay Common
F-1	18z	Relay Contact (NO)
F-2	20z	Relay Contact (NC)
F-OC	22z	Open Collector (OC)
FUA	32d	Open Collector (OC)

The Fault outputs are SPDT relays, 1 open collector output (F-OC) that follows the logic of the relays and 1 open collector output (FUA) dedicated to new fault indications. If the Backwards Compatible configuration is ordered, the FUA will not be present (pin 32d will be for +B, alternate power supply). The Fault outputs are always normally energized when power is applied to the module.

The contact ratings for the A2 & A1 alarm and Fault relays are 4A @ 250 Vac, 3A @ 30 Vdc, *Resistive, maximum*.

Inductive loads (bells, buzzers, relays, etc.) on dry relay contacts must be clamped down. Unclamped inductive loads can generate voltage spikes in excess of 1000 volts. Spikes of this magnitude may cause false alarms and contact damage. Figures 5 & 6 show recommended relay protection circuits for AC and DC loads, respectively.

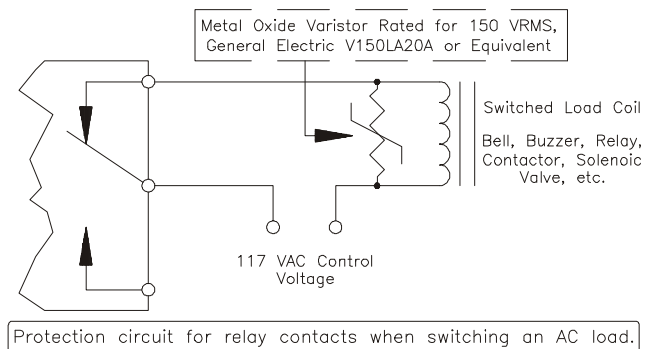

Figure 5



Rear Terminal Connections (continued)

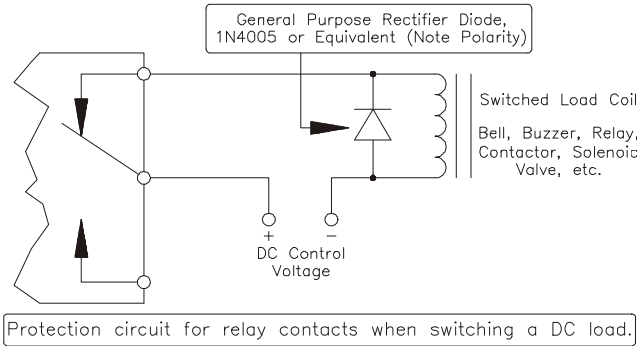

Figure 6

The terminal designation for the Unaccept output is:

Label	Term	Description
UA	18d	Open Collector Output

The terminal designations for the Discrete Inhibit indication is:

Label	Term	Description
CAL/INH	32z	Open Collector Output

If the Backwards Compatible configuration is ordered, the CAL/INH will not be present (pin 32z will be for 0v, alternate COM).

The terminal designations for the Flame Detector connections are:

Label	Term	Description
WHT	26d,z	Signal IN (Analog)
RED	28d,z	VDC Out (+24Vdc)
BLK	30d,z	DC Common

Only one Flame Detector may be connected to a Model TA402A.

Figure 7 illustrates the inter-connections for the Trip Amplifier & the Flame Detector.

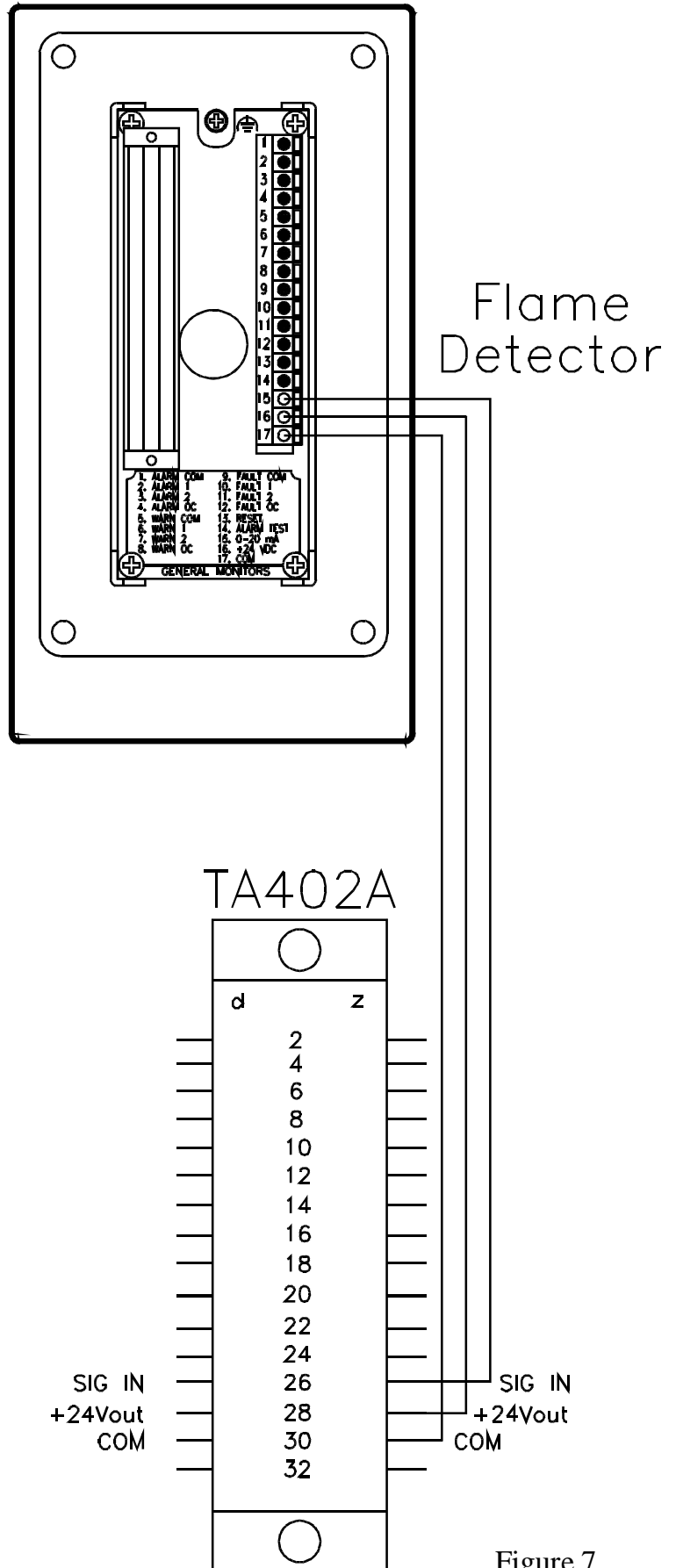

Figure 7



Rear Terminal Connections

(continued)

The electrical rating for all open collector outputs is 100mA @ 35 Vdc.

Figure 8 illustrates some typical open collector external circuits.

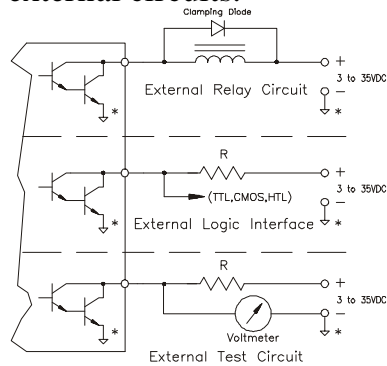

* Note: All system commons (⏚) must be tied together.

Figure 8

NOTE: When any Open Collector Output is connected to a device not powered by the same supply powering the TA402A, it will be necessary to remove (cut) Jumper W11 (see figure 33 on page 35).

The terminal designation for the Card Test Input is:

Label	Term	Description
CT	16d	Switch Connection

The Card Test Input is provided so that the user can access the Card Test feature remotely. One end of a normally open SPST switch is connected to this termination and the other end is connected to system common. To activate the feature, simply press and hold the switch for as long as the test time is to be run (the minimum runtime for this test is equal to the A2 time delay). Figure 9 is a block diagram that shows the switch connections for the Card Test feature.

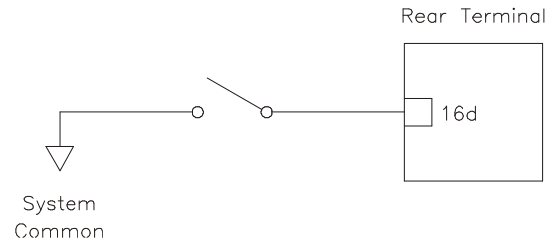

Figure 9

The terminal designations for the Analog Output Signal are:

Label	Term	Description
AO+	20d	Analog Signal (plus)
AO-	22d	Analog Signal (minus)

If the Analog Signal is not used a jumper must be placed between 20d & 22d.

Figure 10 is a diagram of the Analog Signal connections.

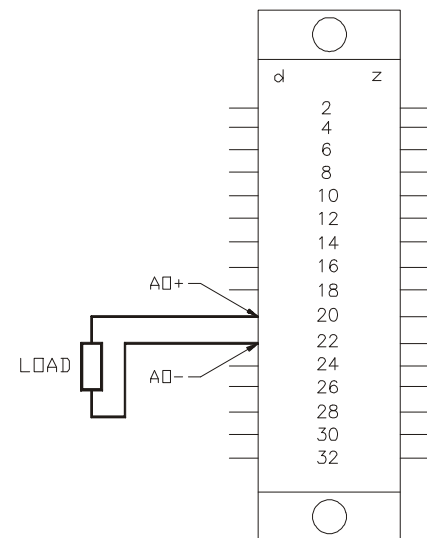

The maximum load resistance between AO+ & AO- cannot exceed 300 ohms.

Figure 10



3.4 Detector Location

Considerations

There are no standard rules for detector placement since the optimum location is different for each application. The customer must evaluate conditions at the detector site in order to make this determination.

Generally:

- The flame detector should be easily accessible for optical checks. Ensure that sufficient clearance exists to allow the use of field devices such as the Air Purge Guard.
- The flame detector head should always be pointing at a slight downward angle to prevent build up of dust and particulate matter on the window(s). Remember that flame detectors are optical devices.
- The flame detector should be located in areas where fires may be likely to occur, if their presence is dangerous.
- Multiple flame detectors should be positioned such that their vertical and horizontal fields of view overlap, to ensure adequate coverage.

3.5 Applying Power

Zero Two Series Modules do not have an ON/OFF power switch. Each module in the Zero Two Series operates from 24 Vdc. Power requirements will vary according to the number and type of modules in the system, as well as the number and type of field devices.

NOTE: if the application of power does not turn ON the unit, check fuse F1 on the control board.

Figure 11 indicates where the power connections for the chassis are made.

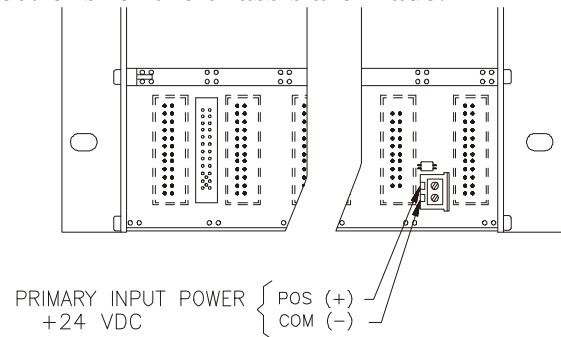

Figure 11



This chapter discusses what general maintenance to perform, describes the electrical inputs, outputs, accepting & resetting alarm, calibration & fault conditions and fault diagnostics.

4.1 General Maintenance

Once the Model TA402A has been installed, very little maintenance is required other than periodic checks to verify the integrity of the system.

- The user should evaluate conditions at the detector site to determine how frequent checks should be performed.
- A functional test of the system should be performed at least once each year. This test should include full operation of stand-by systems or back up power for the prescribed period.
- The power, detector and output wiring should be checked for tightness, verifying that all of the components and devices are connected correctly.
- If the “Password” is disabled, periodic checks of the setup parameters should be performed.

4.2 Electrical Inputs

There are two electrical inputs to the Model TA402A. They are the General Monitors’ Field Device and the Card Test input. Both of these input connections (field device and card test) are made to the rear terminal block (see chapter 3 for more detailed installation information).

- The Flame Detector input consists of the standard three lead connections used with General Monitors’ Field Devices (Black = Common, White = Signal, Red = +24Vdc). See figure 8 on page 10 of this manual.

- The Card Test input consists of a single termination for remote testing of the Model TA402A’s functions. For detailed information on the Card Test, refer to figure 9 on page 11 of this manual.

4.3 Electrical Outputs

The electrical outputs on the Model TA402A consist of relay contacts, open collectors and an analog current signal.

- The following outputs have rear terminal relay contacts:

A1 Alarm - DPDT relay contacts

A2 Alarm - DPDT relay contacts

Fault - SPDT relay contacts

All of the relay contacts on the Model TA402A have a maximum rating of:

4A @ 250Vac, 3A @ 30Vdc resistive

- The following outputs have rear terminal open collectors:

A1 Alarm & LED Mimic

A2 Alarm & LED Mimic

Fault

UA - Unaccepted Alarm

FUA - Unaccepted Fault

CAL/INH - Discrete Inhibit Indication

All of the open collector outputs on the Model TA402A have a maximum rating of:

100mA @ 35Vdc



Electrical Outputs *(continued)*

- The Model TA402A provides an Analog Output Signal for interfacing with other external devices (i.e. PLC, Chart Recorder, etc.). This signal originates at the Flame Detector and passes through “Signal IN” of the Trip Amplifier, out “AO+” to the external device and must be returned to “AO-” of the Trip Amplifier. The signal from the Flame Detector is a stepped 0 to 20mA signal:

0mA	Fault Condition
2mA	COPM Fault (FL310X only)
4mA	Safe Condition
8mA	IR Presence (FL3000, FL3100 only)
12mA	UV Presence (FL3000, FL3100 only)
16mA	Immediate indication of the presence of flame radiation
20mA	Sufficient Flame Radiation present for the duration of a user specified time delay in the Flame Detector

The Model TA402A interprets the analog signal from the Flame Detector as follows:

0mA	Fault Condition, The TA402A will display a Fault Code & activate the Fault LED and circuit.
2mA	COPM Fault, The TA402A will display a Fault Code & activate the Fault LED and circuit.
4mA	Safe Condition, The TA402A will activate the Ready LED.
16mA	Flame Radiation, The TA402A will activate the A1 Alarm LED and circuit and begin the Time Delay count. If a 16mA (or higher) signal is maintained continuously for the period of the Time Delay the TA402A will activate the A2 Alarm LED and circuit.

The maximum resistance load on the Analog Signal loop, including the wire running from the Flame Detector to the Trip Amplifier and to any External Device, must not exceed 300 ohms.

If the Analog Output is not used to interface with an external device, a jumper must be placed between “AO+” & “AO-” on the rear terminal of the Trip Amplifier (see section 3.3, page 10).

4.4 Accepting Alarm Conditions

Whenever a new alarm condition occurs the front panel LED and open collector associated with that alarm (LA1 or LA2) will flash. In addition, the associated alarm outputs and the unaccept outputs (TA402A, UA open collector & FM002A, UA relay) will activate, unless they are already activated. The flashing front panel alarm LED and rear terminal open collector indicate that a new alarm has been activated. New alarms should be acknowledged or accepted. This is accomplished with the Master Accept Button located on the Facilities Module. Pressing the Master Accept Button de-activates the UA outputs and causes the associated front panel alarm LED and rear terminal open collector to stop flashing and energize.

NOTE: Latching alarms must be Accepted before they can be Reset (see section 4.5).

There is a unique situation that may occur with some frequency in certain applications. An alarm may occur and the operator will accept this alarm by pressing the Master Accept Button. If the alarm output is latching and the condition at the detector returns to normal (safe) the alarm output will need to be reset. If, however, the alarm output is accepted but not reset and that alarm condition occurs again, the front panel LED, the associated mimic open collector and the unaccept outputs will reflash or re-activate. This gives the operator an indication of a new alarm condition that must be re-accepted.



Accepting Alarm Conditions

(continued)

A type of alarm, other than the A1 & A2 alarms, is the fault alarm. The fault alarm can be accepted similarly with the A1 & A2 alarms. The front panel fault LED will flash and the fault unaccept (FUA) open collector will energize when a fault is detected. If the operator presses the accept button, the FUA output will de-energize and the Fault LED will stop flashing, but stay illuminated until the fault condition is corrected.

4.5 Resetting Latched Alarms

The user may select a “latching” or “non-latching” alarm output for A1 and/or A2. If an alarm output activates and the condition that caused that activation is no longer present, a non-latching alarm output will reset automatically, however, a latched alarm output will need to be reset manually. Resetting latched alarm outputs is accomplished with the Master Reset Button located on the Facilities Module (FM002A). Pressing the Master Reset Button will reset any latched conditions that are no longer valid as well as a latched COPM error (F5 fault) that is no longer valid (see section 4.8).

NOTE: Latched alarms cannot be Reset until they have been Accepted (see section 4.4).

The Master Reset Button performs another function. If the operator presses and holds the Master Reset Button for two or more seconds, all of the LEDs and LED segments in the digital display will illuminate for as long as the operator presses the button. This is called the LED Test. The LED test cannot be performed while the unit is in alarm or fault or during a Card Test.

4.6 CAL/INH Open Collector

There is an open collector that will energize anytime the Model TA402A is placed in the Inhibit Mode. The Model TA402A ignores the CAL portion of this output because the Flame Detector cannot be placed in a CAL or CAL Check Mode. This open collector output is referenced to the system’s ground or common. Energizing this output merely provides a path to ground as is the case with all energized open collector outputs. De-energized, this output will be in a high impedance state.

4.7 Card Test Feature

The Card Test Input is provided so that the user can access the Card Test feature remotely. One end of a normally open SPST switch is connected to this termination and the other end is connected to system common (see figure 9 on page 11).

To activate the Card Test feature, simply press and hold the switch for at least three seconds. Each alarm level (A1 & A2) will trip when the alarm setpoint and time delay are exceeded. At the conclusion of the Card Test, the A1 & A2 outputs will automatically reset (overriding any latching option). A Card Test cannot be initiated if the unit is in alarm or fault or during an LED Test.

NOTE: The relays (A1 & A2) and open collector outputs are active and will trip during the Card Test, unless the user specified option disabling these outputs is selected during the Setup Mode. This should be treated as a functional test of a Zero Two System.

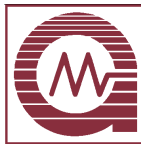

4.8 Fault Diagnostics

In addition to the Fault LED on the front panel, the Model TA402A provides a fault code on the digital display whenever a fault condition occurs. The Fault Codes that can appear on the digital display are summarized below:

- **F1, F2, & F9** - Are not used at this time. These codes have been reserved for future use.
- **F3** - Program checksum error. This fault occurs during initial power-up of the unit. If this fault occurs, remove and reapply power to the unit. If the fault continues to occur, replace the unit and consult your GMI Representative or the factory.
- **F4** - Flame Detector error. Make sure the wires running to and from the Trip Amplifier and the Flame Detector are connected properly. Check for opens and shorts across the field wiring. Make sure the analog signal is returned to the field device or common (jumper AO+ & AO- if unused). Check Fuses F2 & F3.
- **F5** - Flame Detector COPM Error. This error indicates that the flame detector COPM circuitry has detected an error. Please refer to the Flame Detector Manual for further details.
- **F6** - Low supply voltage. Make sure the supply voltage level at the chassis is

24Vdc.

F7 - EEPROM verification failure. This fault will occur if the microprocessor can not store setup information in the EEPROM. If this fault occurs consult the factory or your GMI Representative.

- **F8** - Failed to complete setup. This fault may occur during or immediately after the Setup Mode. If this fault occurs consult the factory or your GMI Representative.

In each of the fault cases listed on this page, when the fault occurs the FUA output is activated. Pressing the **ACCEPT** button on the Facilities Module (FM002A) will acknowledge the fault, de-activate the FUA output and the fault LED will stop flashing and remain **ON** until the fault is corrected.

In addition, the F5 - Flame Detector COPM Error is latched on upon the first occurrence of this error in the flame detector. Resetting this latched fault is accomplished with the Master Reset Button located on the Facilities Module (FM002A). The Master Reset Button will reset the latched F5 fault only if the COPM error is no longer present at the flame detector. Pressing the Master Reset Button will also reset any latched alarms that have been accepted (see section 4.5). Unlike latched alarms, the COPM Error (F5 fault) does not have to be accepted prior to resetting it.



This chapter discusses the user interfaces, the Setup Check & Setup Modes and the Inhibit Mode.

5.1 Types of User Interfaces

User interfaces are provided so that the operator may interpret and direct the Model TA402A in the performance of its various functions. User interfaces (figure 12) consist of a digital display, status indicators and a Mode/Select switch.

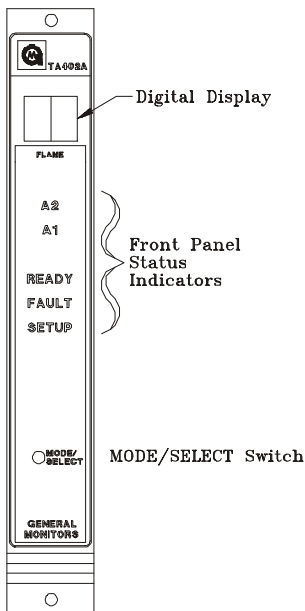

The digital display provides the user with the fault diagnostic codes and setup parameters. The status indicators provide the user with an indication of the current mode of operation (alarm, fault, ready and setup). The Mode/Select switch provides the user access to the Setup Check, Setup and Inhibit modes.

Figure 12

5.2 Setup Check & Setup Modes

The Setup Check Mode allows the operator to view the selected options for the module without allowing any changes to be made. Once this mode has been entered, the module will automatically display each of the selected options for a short period of time. The Setup Mode allows the operator to change the operating parameters by making choices for selected options.

The Setup Check and Setup Modes display identical information with the following exceptions:

- The Setup Check Mode allows the user to view the operating parameters of the Model TA402A, whereas the Setup Mode allows the user to change these parameters.
- Entering the optional Password is only available in the Setup Mode.
- The Inhibit Mode may only be entered from the Setup Mode. If the Inhibit Mode is entered, the unit will remain in the Inhibit Mode until the Mode/Select switch is pressed.
- After the Setup Mode is complete the TA402A will execute the Setup Check Mode to view the selected parameters.

NOTE: *The Setup and Setup Check Modes cannot be entered if the unit is in alarm or fault.*

During the Setup Mode the operator will be allowed to select options. The selection procedure is the same for most of the options. Pressing the Mode/Select Switch toggles the available choices. When the display has indicated a choice for five consecutive seconds, without the operator pressing the Mode Select Switch, the Setup routine will accept that selection and move on to the next option available. These modes will activate the CAL/INH output and the CALBUSS.

NOTE : *Before entering the Setup Mode to make changes, the user should become familiar with the block diagram on page 18 and fill out the form listed there. This will aid the user during the selection process in the Setup Mode.*



Setup Check & Setup Modes *(continued)*

This section is provided to aid the operator in making selections during the Setup Mode. It is recommended that the operator fill in the selections in the proper blanks and then use this page as a reference while programming the TA402A. The blocks shown below indicate the order of options in the Setup Mode. To the right of each block is a description of the choice(s) that are available. More information about making each selection is provided in the pages that follow.

<p>Password</p>	<p>Enter the Password, if the Password is enabled.</p>	
<p>Inhibit Mode</p>	<p>Enter the Inhibit Mode, if desired.</p>	<p><u>ENTER SELECTION</u></p>
<p>A2 Alarm Options</p>	<p>Set the Energized (En) / De-Energized (dE) Option Set the Latching (LA) / Non-Latching (nL) Option Set the Time Delay (1, 2, 4, or 8 seconds)</p>	<p>_____ _____ _____</p>
<p>A1 Alarm Options</p>	<p>Set the Energized (En) / De-Energized (dE) Option Set the Latching (LA) / Non-Latching (nL) Option</p>	<p>_____ _____</p>
<p>Fault/Inhibit Option</p>	<p>Set the Fault Activate (Ac) or not (nA) during Inhibit Option</p>	<p>_____</p>
<p>Card Test Options</p>	<p>Display will indicate "ct" for 5 seconds</p>	
	<p>Set the Alarm outputs for Active (Ac) or Not Active (nA)</p>	<p>_____</p>
<p>Password Options</p>	<p>Set the Password to be Disabled (Pd) or Enabled (PE) If the Password is Enabled:</p>	<p>_____</p>
	<p>Set the password digits Left _____ Right _____</p>	
<p>Setup Check Mode</p>	<p>After all of the options have been selected, the TA402A will enter the Setup Check Mode.</p>	



Setup Check & Setup Modes *(continued)*

NOTE: *The Password and the A2 Alarm time delay options offer the operator more than two choices. While these options are being selected, pressing the Mode/Select Switch will sequence the display to the next available choice for that option.*

ENTERING THE SETUP MODE

To Enter the Setup Check Mode or the Setup Mode, press and hold the Mode/Select switch until the **SETUP** LED begins flashing (about ten seconds). When the **SETUP** LED is flashing, release the Mode/Select switch to enter the Setup Check Mode (figure 13). Continuing to press and hold the Mode/Select switch until the **SETUP** LED stops flashing (about fifteen seconds) will allow the operator to enter the Setup Mode. When the **SETUP** LED stops flashing and stays on, release the Mode/Select switch and the unit will enter the Setup Mode (figure 13).

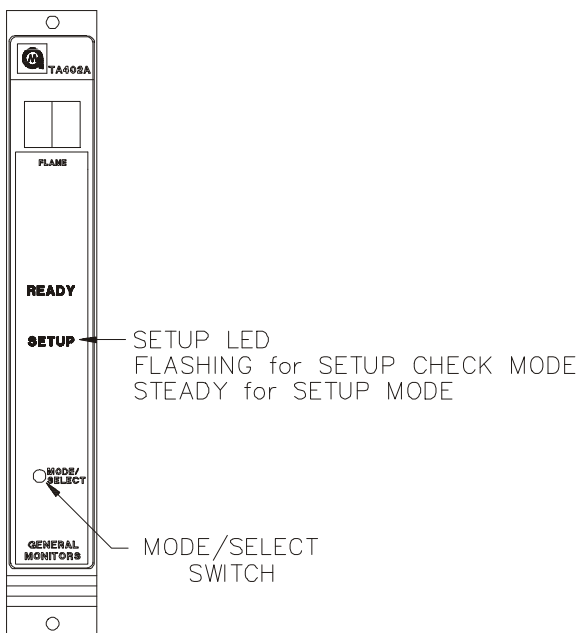

Figure 13

ENTERING THE PASSWORD

- This option applies to the Setup Mode only:** If the password option is enabled, the right digit of the display will be blank and a bar (-) will appear in the left digit on the display (figure 14). Press the Mode/Select switch until the desired number is displayed, then wait about five seconds. The left digit of the display will be blank and a bar (-) will appear in the right digit on the display (figure 14). Press the Mode/Select switch until the desired number is displayed, then wait about five seconds. If the password is correct the user will proceed with the inhibit option. If the password is incorrect the user will not be able to proceed and unit will return to the normal operating mode. Once in the operating mode the user may attempt to re-enter the Setup Mode. The factory default password is 00.

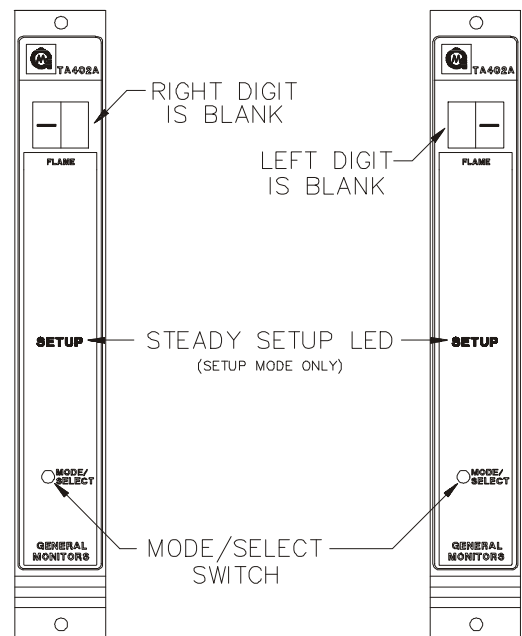

Figure 14

**Setup Check & Setup Modes** *(continued)***ENTERING THE INHIBIT MODE**

- **This option applies to the Setup Mode only:** If the password option is disabled, or after the correct password has been entered, the display will indicate **In** for five seconds (figure 15). Pressing the Mode/Select switch while **In** is displayed, will cause the unit to enter the Inhibit mode by inhibiting the alarm outputs. After the Model TA402A has entered the Inhibit mode, pressing the Mode/Select switch causes the unit to return to normal operation (see section 5.3). If it is desired to enter the Setup Mode, do not press the Mode/Select switch for the five seconds **In** is displayed.

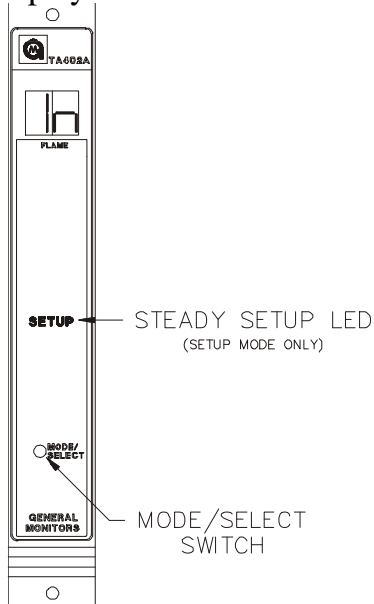

Figure 15

A2 ALARM OPTIONS

- After the Inhibit mode option, the **A2** LED on the front panel will be flashing while the Energized/De-energized option is displayed (figure 16). The display will indicate the current selection, (**En** or **dE**). Press the Mode/Select switch until the desired option is displayed. De-Energized is the factory default for this selection.

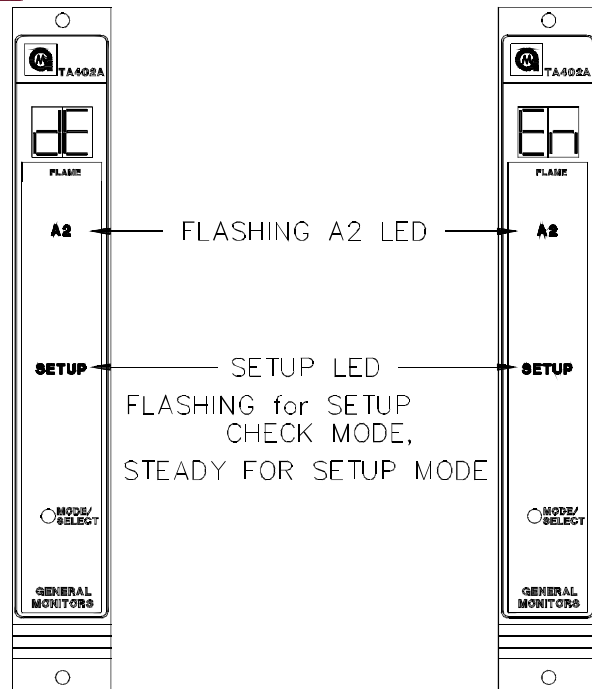

Figure 16

- The **A2** LED on the front panel will be flashing while the latching/non-latching option is displayed (figure 17). The display will indicate the current selection, (**nL** or **LA**). Press the Mode/Select switch until the desired option is displayed. Latching is the factory default for this selection.

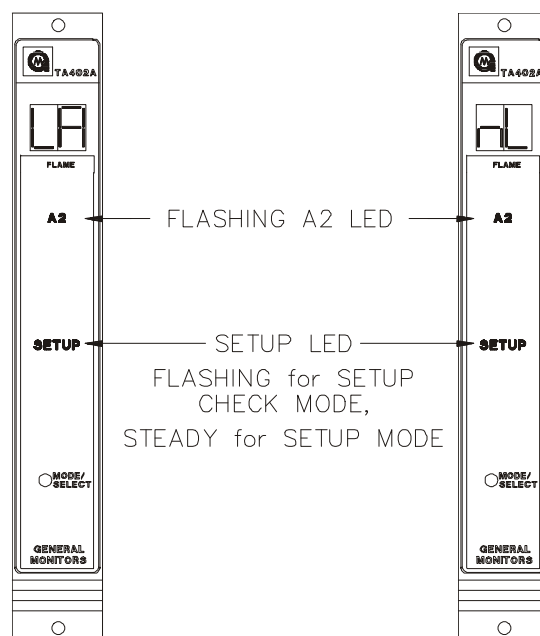

Figure 17



Setup Check & Setup Modes (continued)

- The last A2 alarm option to appear on the display will be the alarm time delay. If the A1 alarm is activated continuously for the amount of time specified by this option the A2 alarm outputs will activate. The display will indicate the current A2 alarm time delay in seconds (figure 18). Press the Mode/Select switch repeatedly, until the desired A2 alarm time delay (1, 2, 4 or 8 seconds) appears on the display. **4** is the factory default for this selection.

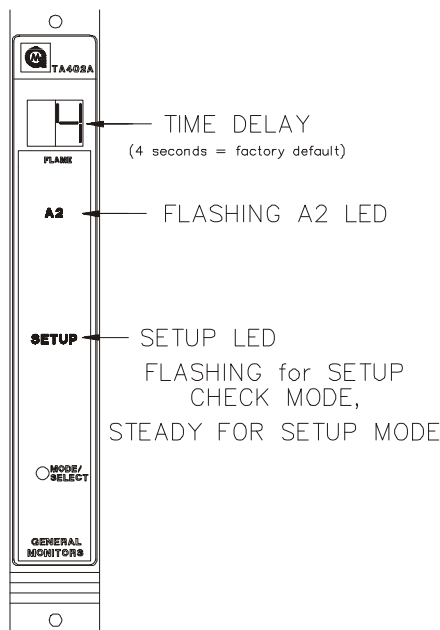

Figure 18

A1 ALARM OPTIONS

- Next, the **A1** LED on the front panel will be flashing while the Energized/De-energized option is displayed (figure 19). The display will indicate the current selection, (**En** or **dE**). Press the Mode/Select switch until the desired option is displayed. De-Energized is the factory default for this selection.

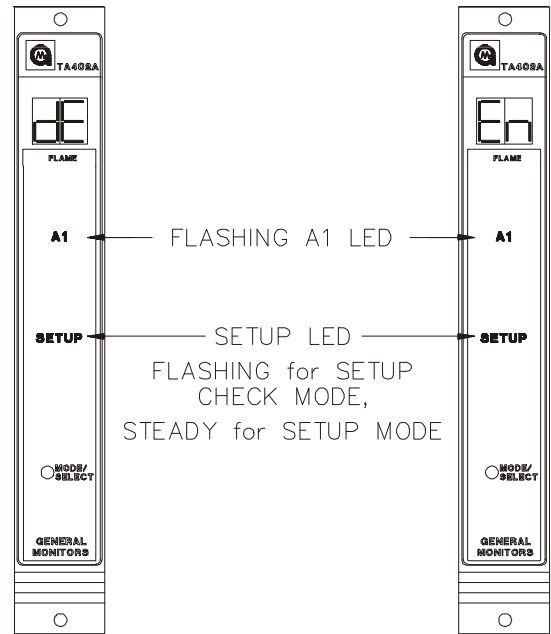

Figure 19

- The **A1** LED on the front panel will be flashing while the latching/non-latching option is displayed (figure 20). The display will indicate the current selection, (**nL** or **LA**). Press the Mode/Select switch until the desired option is displayed. Non-Latching is the factory default for this selection.

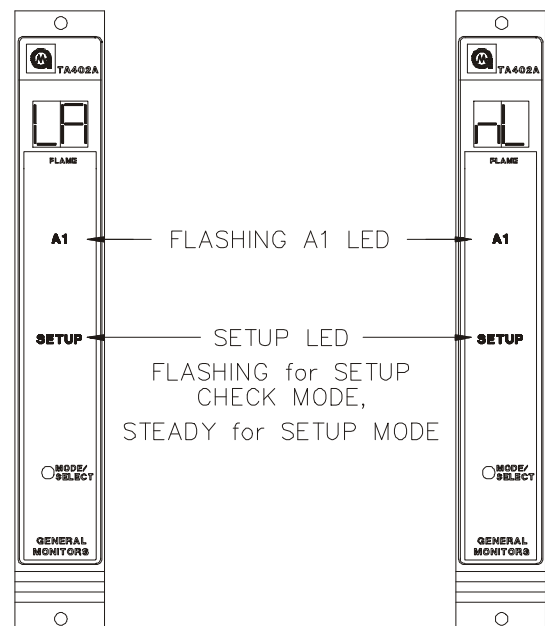

Figure 20

**Setup Check & Setup Modes** (continued)**FAULT / INHIBIT OPTION**

- After the A1 alarm options have been selected, the user will select the Fault/Inhibit option. The **FAULT** LED on the front panel will be flashing while the display indicates **Ac** or **nA** (figure 21). An **Ac** selection specifies that the Model TA402A will activate the Fault circuit while the unit is in the Inhibit Mode. An **nA** selection specifies that the Model TA402A will not activate its Fault circuit when the unit is placed in the Inhibit Mode (see section 5.3). An **nA** selection will not disable the Fault circuit, therefore, if a Fault occurs during the Inhibit Mode, the unit will activate the Fault circuit. Press the Mode/Select switch until the desired option is displayed. Not Active is the factory default for this selection.

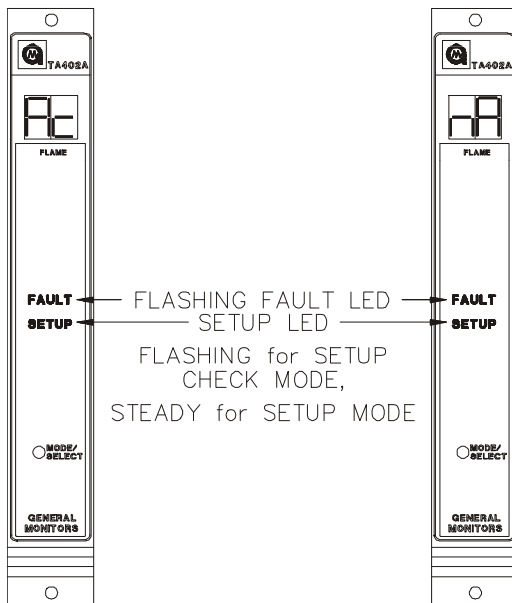

Figure 21

CARD TEST OPTIONS

After the Fault/Inhibit option has been selected, the user will select whether or not the alarm outputs will activate during a Card Test. The display will indicate **ct** for about five seconds (figure 22).

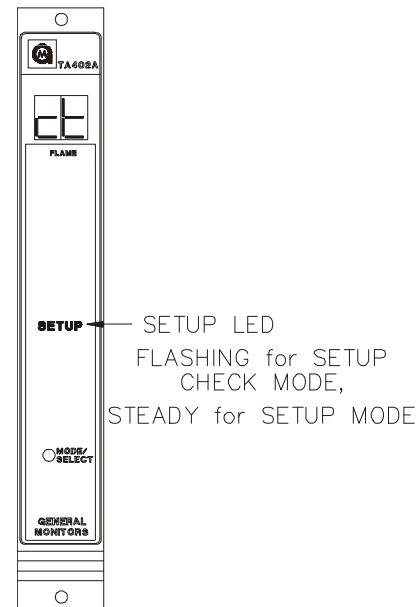

Figure 22

- Following **ct**, the display will indicate the alarm output option during a Card Test as either **Ac**, active or **nA**, not active (figure 23). Press the Mode/Select switch until the desired option is displayed. Not Active is the factory default for this selection.

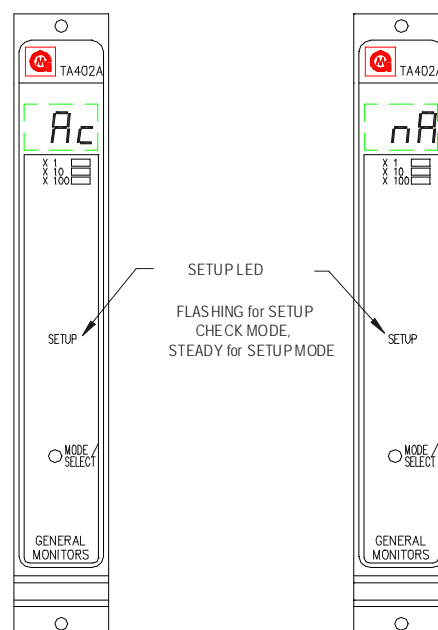

Figure 23



Setup Check & Setup Modes (continued)

NOTE: Selecting *nA* option for the Card Test will not inhibit the Fault or A1/A2 alarm circuits in the event of a malfunction or an alarm condition, during normal operation.

PASSWORD OPTION

Once the Card Test options have been selected, the user will either enable or disable the password option (figure 24). The display will indicate either **PE**, for enabled or **Pd**, for disabled. Press the Mode/Select switch until the desired option is displayed. Password Disabled is the factory default for this selection.

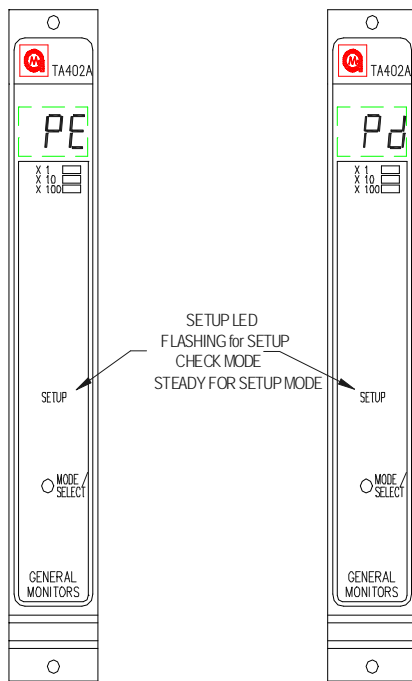

Figure 24

ENTERING A NEW PASSWORD

This option applies to the Setup Mode only: If the Password is disabled, the unit will automatically enter the Setup Check mode. If the Password is enabled, the user will be able to enter a new password (refer to the NOTE on page 19). The unit will display the left digit of the Password on the display. The right digit will be blank until the left digit has been selected. Once the left digit is selected, wait for five seconds. Next, the right digit will be displayed and the left digit will be blank until the right digit has been selected. Once the right digit has been selected, wait for five seconds (figure 25).

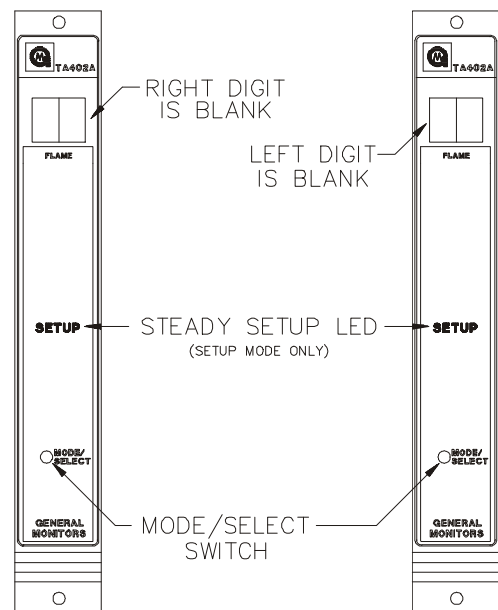

Figure 25

When the Setup Mode is complete, the Model TA402A will automatically enter the Setup Check Mode. This allows the operator to view the newly selected options. The unit will return to normal operation after completing the Setup Mode and the Setup Check Mode.



5.3 Inhibit Mode Description

Whenever the Inhibit Mode is entered (see section 5.2), the A1 and A2 rear terminal alarm outputs are inhibited. The front panel A1 and A2 LEDs will still function normally, in cases where sufficient UV/IR radiation is present. If the password option is disabled, or after the correct password has been entered, the display will indicate **In** for five seconds (figure 15 on page 19). Pressing the Mode/Select switch while **In** is displayed, will cause the unit to enter the Inhibit mode by inhibiting the alarm outputs. After the Model TA402A has entered the Inhibit mode, pressing the Mode/Select switch causes the unit to return to normal operation. If it is desired to enter the Setup Mode, do not press the Mode/Select switch for the five seconds that **In** is displayed.

NOTE: Any latched alarms *must* be reset before exiting the Inhibit Mode.

There is a user selectable option that will place the unit in Fault every time the Inhibit Mode is entered. If the operator does not select this option the Fault circuits will function normally during the Inhibit Mode (i.e. they will not be inhibited).

While the unit is in the Inhibit mode, the display will indicate **In** for 5 seconds, then be blank for 5 seconds. This sequence will repeat for as long as the unit is in the Inhibit mode.

The Inhibit Mode is provided so that the operation of Model TA402A can be verified without tripping external devices that are connected to the A1 and A2 outputs. This type of verification usually occurs during “Initial Start-Up” and/or “Commissioning”.



This chapter provides a description of the flame detectors and the accessories, that can be used with them.

6.1 Flame Detectors

There are 6 Flame Detectors designed for use with the Model TA402A. Each detector has unique features and advantages:

- FL3000 UV/IR Flame Detector

The FL3000 (figure 26) has a very high degree of discrimination when it comes to identifying UV and IR radiation sources. Only the correct combination of each type of radiation will signal a fire.

Figure 26

- FL3001 UV Flame Detector

The FL3001 (figure 27) has been optimized for speed of response. Typical response times are less than 1 second for 1 square foot fires within the field of view of this detector.

Figure 27

- FL3002 Enhanced IR Flame Detector

The FL3002 (figure 28) can see fires through thick or heavy smoke. The optics on this detector are not easily obstructed by grease on the lenses or air borne particles/debris.

Figure 28

1



- **FL3100 UV/IR Flame Detector**

The FL3100 (figure 29) has a very high degree of discrimination when it comes to identifying UV and IR radiation sources. Only the correct combination of each type of radiation will signal a fire.



Figure 29

- **FL3101 UV Flame Detector**

The FL3101 (figure 30) has been optimized for speed of response. Typical response times are less than 1 second for 1 square foot fires within the field of view of this detector.



Figure 30

- **FL3102 Enhanced IR Flame Detector**

The FL3102 (figure 31) can see fires through thick or heavy smoke. The optics on this detector are not easily obstructed by grease on the lenses or air borne particles/debris.



Figure 31



6.2 UV Phototube

The UV phototube is used in the Models FL3000, FL3100, FL3001, FL3101. This phototube responds to UV radiation within a range of 185nm to 260nm (wavelength). The shortest wavelength of energy from the Sun (figure 30), that reaches the Earth's surface is about 300nm. Therefore, the UV phototube will not respond to energy from sunlight.

6.3 Pyroelectric Device

The pyroelectric device is used in the Models FL3000 and FL3002. This device responds to a change in IR radiation with a wavelength centered on 4.3 microns (figure 29). The circuit using the pyroelectric device in the detector is designed such that the "flicker rate" of IR radiation from a flame can be compared with the known "flicker rate" of fire.

6.4 Thermopile

The thermopile device is used in the Model FL3002. This device measures the intensity of IR radiation with a wavelength centered on 4.3 microns. The thermopile device will not respond to energy from sunlight at this wavelength because most of it is absorbed (or attenuated) by carbon dioxide in the atmosphere.

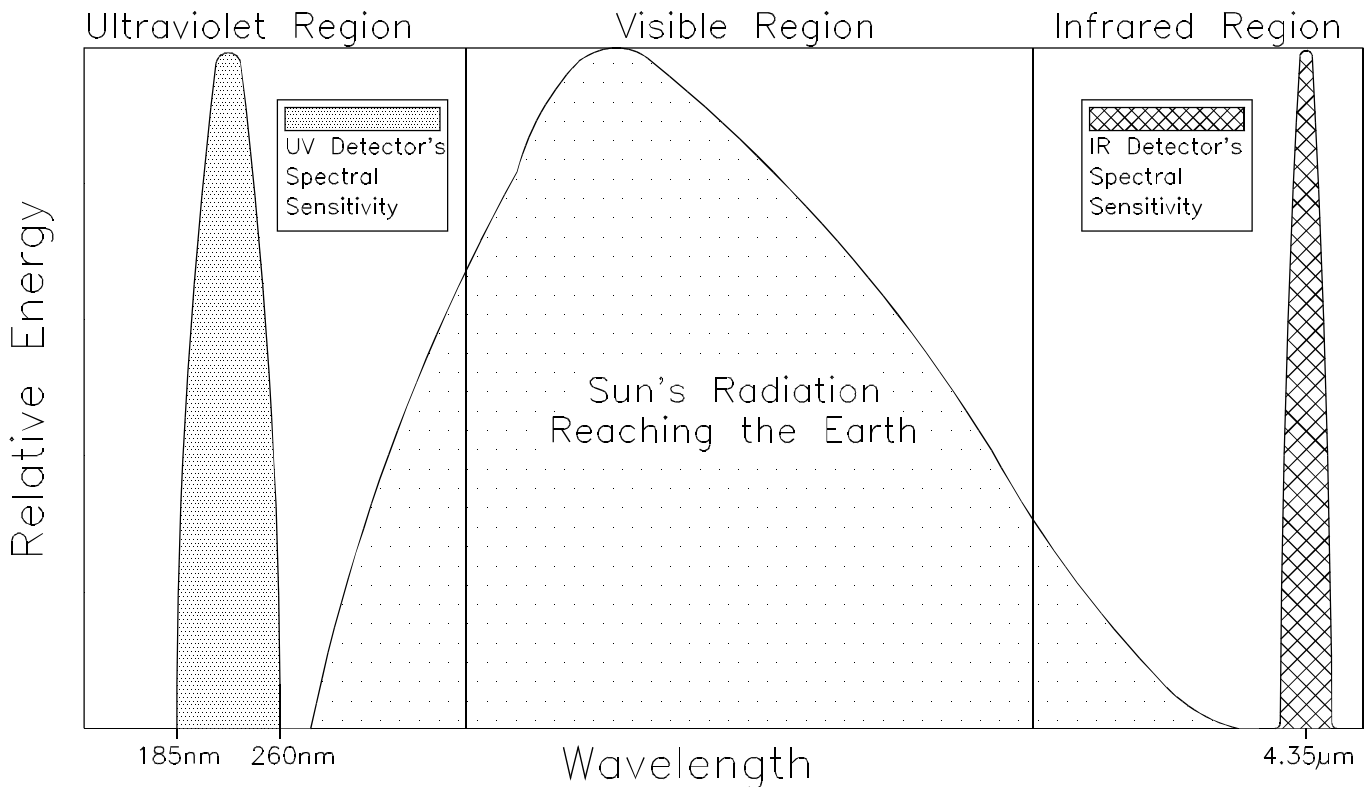

Figure 32



6.5 Test Lamps

TL100

The General Monitors TL100 Test Lamp is a portable, rechargeable source of ultraviolet radiation, specifically designed for use in testing UV flame detection systems. It emits a wide band of radiation and specifically covers the 185 to 260 nanometer region which corresponds with the response of most ultraviolet flame detectors. The TL100 Test Lamp is CSA certified intrinsically safe for use in Class I, Division 1, Groups C and D and therefore does not require an explosion proof housing.

NOTE: To avoid damaging exposure to ultraviolet radiation, The TL100 provides a Power On indicator so that direct viewing is not necessary.

The TL100 has two intensity levels, LO and HI as indicated on the rocker switch label. With the switch in the HI position, the Test Lamp is capable of activating General Monitors UV flame detection systems at distances up to 40 feet (12 meters) from the detector. The LO switch will activate the system at distances up to 20 feet (6 meters).

To operate the Test Lamp, aim it directly at the detector to be tested and activate the desired intensity level. The ON LED (green) should light, indicating power on and the Low Battery LED (red) should remain off, indicating sufficient charge for normal operation. The response of the system will depend on the distance from the detector as well as the sensitivity and/or time-delay settings at the detector and the control module. If the system is operating normally, it will respond immediately upon activating the TL100. If the TL100 remains ON for the period set by the time delay setting, the detector and control module will go into Alarm.

If during operation, the low battery LED (red) is illuminated, the batteries are nearing discharge. However, there is a built in battery reserve of approximately 15 minutes. It is recommended that the batteries be recharged as soon as possible after this period. Do not allow the TL100 batteries to remain in a discharged state.

Recharging must be done in a non-hazardous area. Recharging the batteries is required whenever the Low Battery LED (red) is illuminated. Plug the charger into a suitable outlet and insert the charging plug into the receptacle located on the back end of the Test Lamp. Fourteen to sixteen hours are required for a complete charge. Although over-charging up to twenty-four hours is tolerable, however, it is not recommended because over-charging reduces battery life. If the TL100 is not used for an extended period of time, it is recommended that it be charged bi-monthly to prevent excessive discharge. The batteries in the TL100 may be recharged on an average of 500 times and they are not replaceable.

TL102

Due to the advanced discrimination in the Model FL3000 and FL3002 flame detectors, the Model TL102 UV/IR Test Lamp was developed. The General Monitors TL102 Test Lamp is a battery operated, rechargeable test source specifically designed to test General Monitors UV/IR and Enhanced IR Flame Detection Systems. This Test Lamp consists of a high-energy broad band radiation source which emits sufficient energy in both ultraviolet and infrared spectra to activate UV, UV/IR and/or IR Flame Detection Systems. To simulate a fire, the test lamp automatically flashes at one of three DIP switch selectable rates.



Test Lamps - TL102 *(continued)*

The Model TL102 is designed for explosion proof applications for use in Class I, Division 1, Group B, C & D areas. The test lamp operates on internal lead-acid batteries which, when fully charged, will operate continuously for 25 to 30 minutes. An internal circuit will prevent operation when the batteries are low.

It is always important to start a series of TL102 checks with a fully charged unit. Stand 20 feet (for the FL3000 & FL3002) or within 35 feet (for the FL3001) of the unit to be tested and aim the TL102 directly into the detector face squarely. If the system is operating normally, the detector will go into a WARNing (A1 alarm) condition after a few flashes. If the Lamp remains ON for the time-delayed period, the detector will go into ALARM.

To conserve the charge, do not operate the Test Lamp longer than is necessary to test each detector. When the batteries are low the Test Lamp will shut off until the batteries have been recharged.

Recharging must be done in a non-hazardous area. The charging receptacle is located inside the housing, under the knurled plug. To recharge the batteries, insert the charging plug into an outlet and remove the knurled plug located next to the ON button. It is recommended that the TL102 be kept on charge when not in use to prevent excessive battery discharge. The batteries may be recharged an average of 500 times and the battery pack is replaceable.



Glossary of Terms

AC - Alternating Current.

Analog - Continuous, without steps.

Ambient Temperature - Surrounding or background Temperature.

AWG - American Wire Gauge.

Canadian Standards Association - CSA is an approval agency. Testing laboratories will test Gas Detection Instruments to the standards set by approval agencies such as CSA. CSA certification is required for selling such equipment in Canada. CSA standards are recognized by many organizations outside of Canada.

Class I, Division 1 - This is a National Electric Code (NEC) classification dealing with hazardous locations and the degree with which the hazard is present. Class I, Division 1 is defined as any location where ignitable concentrations of flammable gases or vapors may be present under normal operating conditions. For more information on hazardous locations, refer to the NEC Handbook, Article 500.

COM - Common.

Conduit - Tubing, piping or a protected trough for electrical wires.

DC - Direct Current.

DCS - Distributed Controls System.

Digital - Stepped in specific increments.

Drain Loop - The purpose of a drain loop is to collect condensation so as to prevent moisture from entering the housing.

EEPROM - Electrically Erasable Programmable Read Only Memory.

EMI - Electro-Magnetic Interference.

Flicker Rate - The rate at which the intensity of IR radiation from a fire changes or modulates.

FMRC - Factory Mutual Research Corporation.

Group B - Atmospheres containing more than 30% Hydrogen or gases/vapors of equivalent hazard.

Group C - Atmospheres such as cyclopropane, ethyl ether, ethylene, or gases/vapors of equivalent hazard.

Group D - Atmospheres such as acetone, ammonia, benzene, butane, ethanol, gasoline, hexane, methanol, methane, natural gas, naphtha, propane, or gases/vapors of equivalent hazard.

Halogen Free Solvent - Solvent that does not contain any of the following: astatine, bromine, chlorine, flourine, or iodine.

IR Radiation - Infrared Radiation. Energy with wavelengths longer than the red end of the visible spectrum but shorter than radio waves.

Latching - Holding on to. Latching Alarms require manual resetting.

mA - Milliamperere, one thousandth (.001) of an amp.

Microprocessor Base Electronics - All of the input signal processing, fault monitoring, calibrating routines, setup routines, and the outputs are under the control of a microprocessor unit (MPU).

mV - Millivolt, one thousandth of a volt.

PCB - Printed Circuit Board.

PLC - Progammmable Logic Controller.

RFI - Radio Frequency Interference.



Glossary of Terms *(continued)*

TB - Terminal Block.

UV Radiation - Ultraviolet Radiation.
Energy with wavelengths shorter than the violet end of the visible spectrum but longer than X-Rays.



Engineering & Technical Drawings

Reference Drawing # 11145-2

Schematic Diagram - Detector Input Circuit

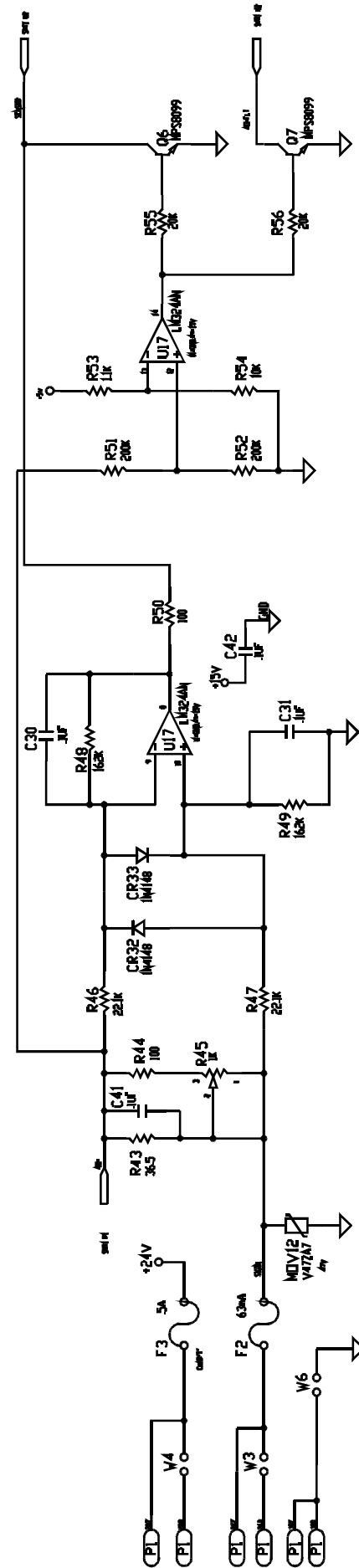

Figure 33



Engineering & Technical Drawings

(continued)

Reference Drawing # 11145-1

Schematic Diagram - Control Electronics

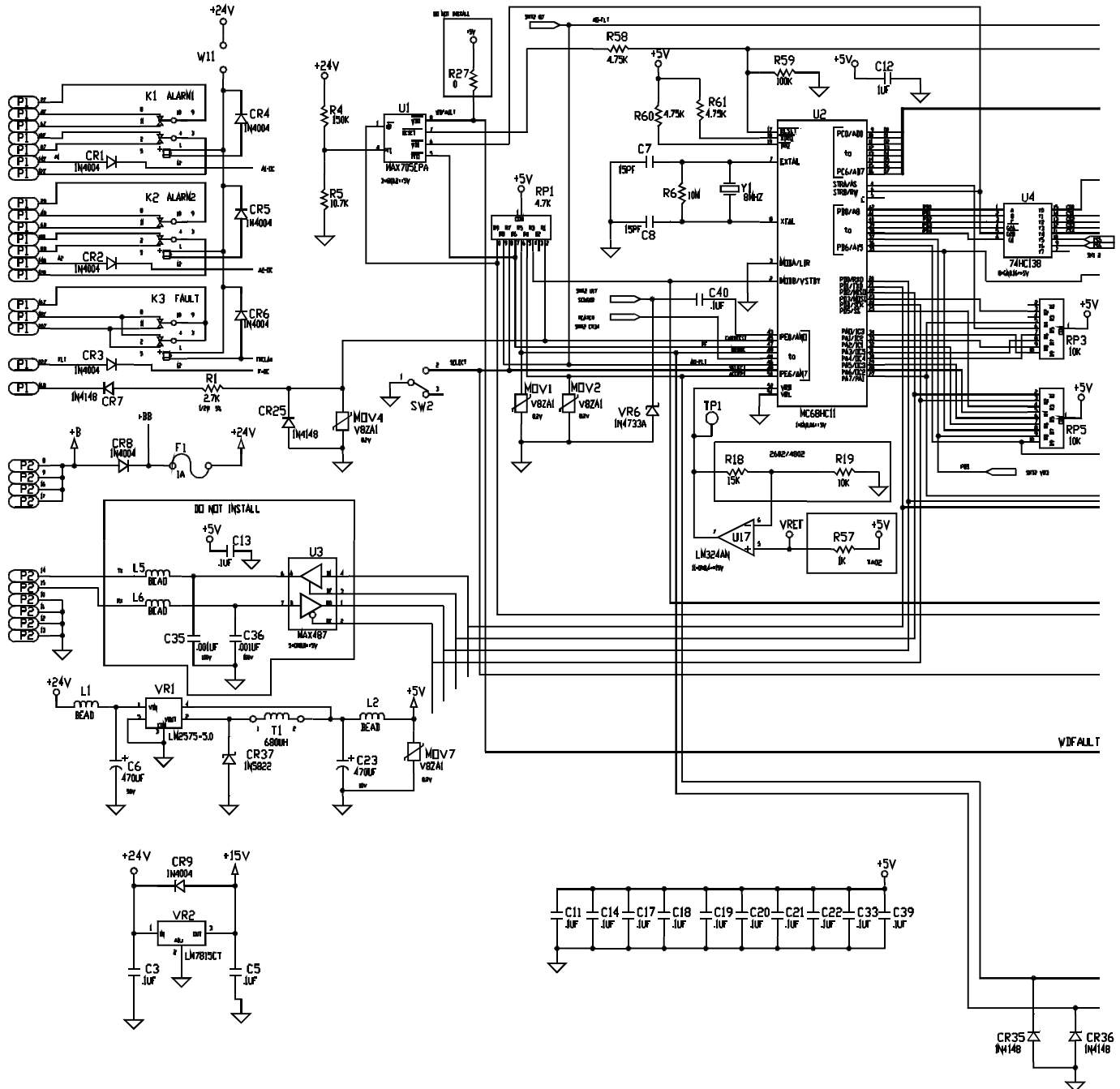

Figure 34
Left Side



Engineering & Technical Drawings

Reference Drawing # 11145-1

(Continued)

Schematic Diagram - Control Electronics

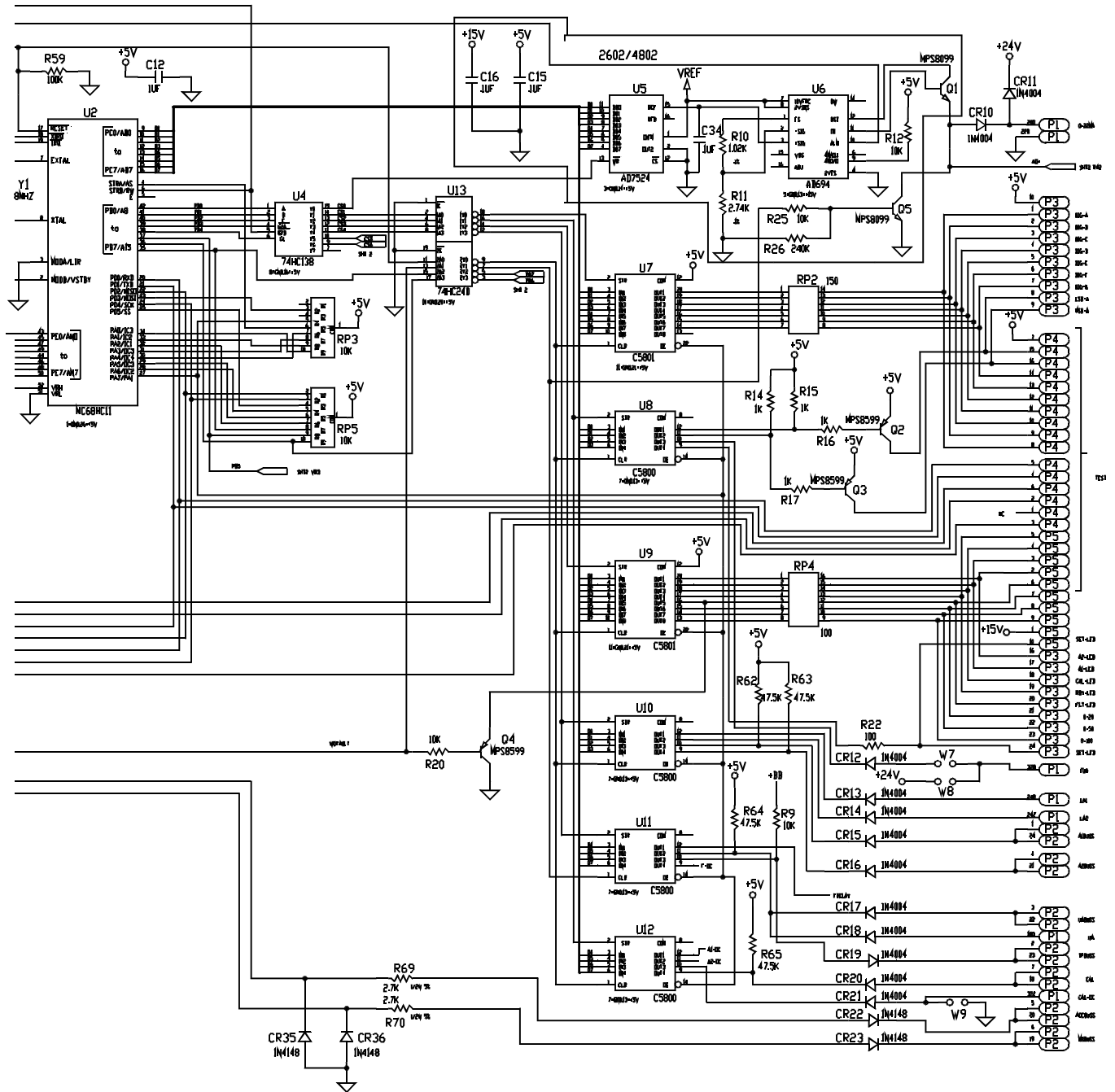

Figure 35
Right Side



Engineering & Technical Drawings
(continued)

Reference Drawing # 11150-2
Schematic Diagram - Display Electronics

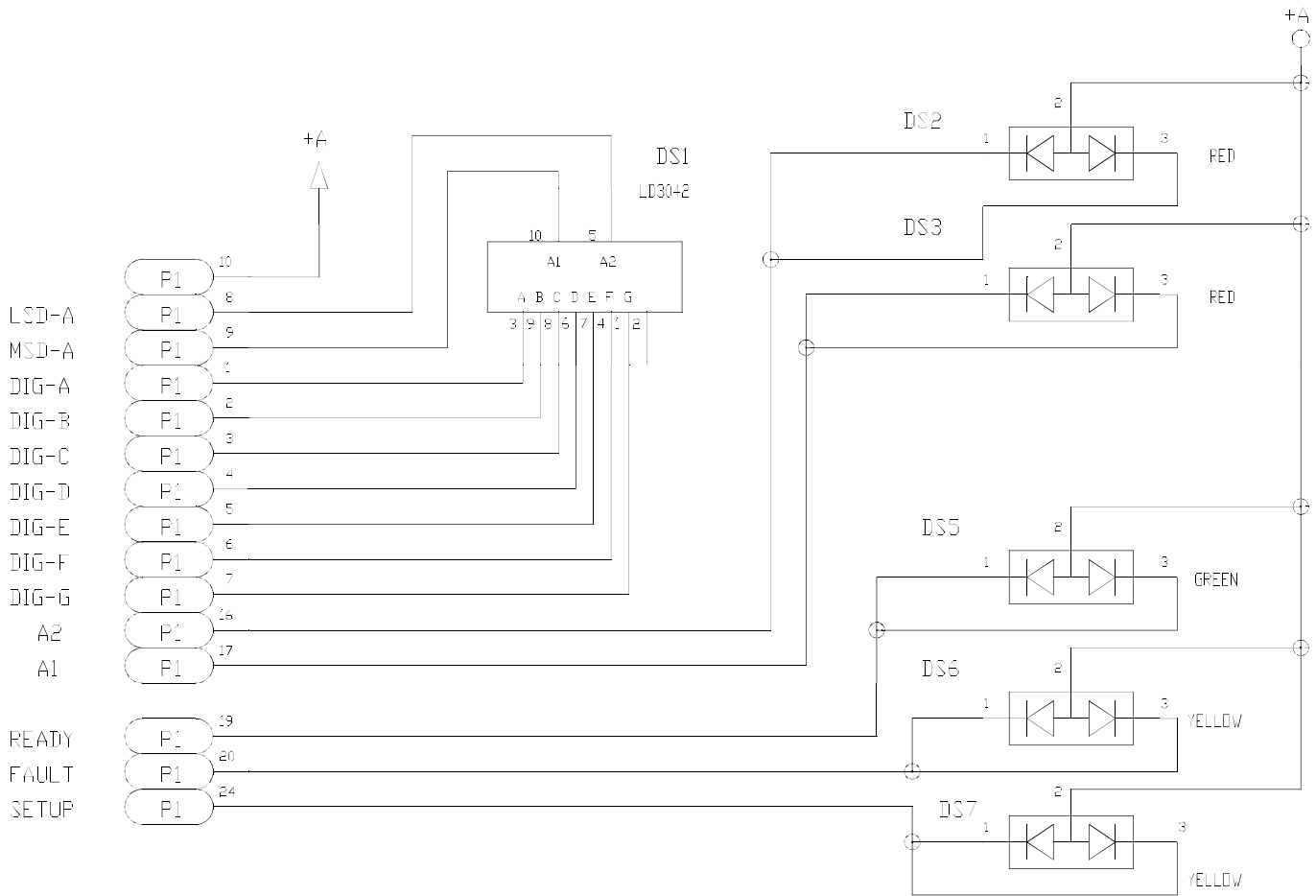

Figure 36



Engineering & Technical Drawings

Reference Drawing # 11146-3

(continued)

Circuit Card Assembly - Control Board

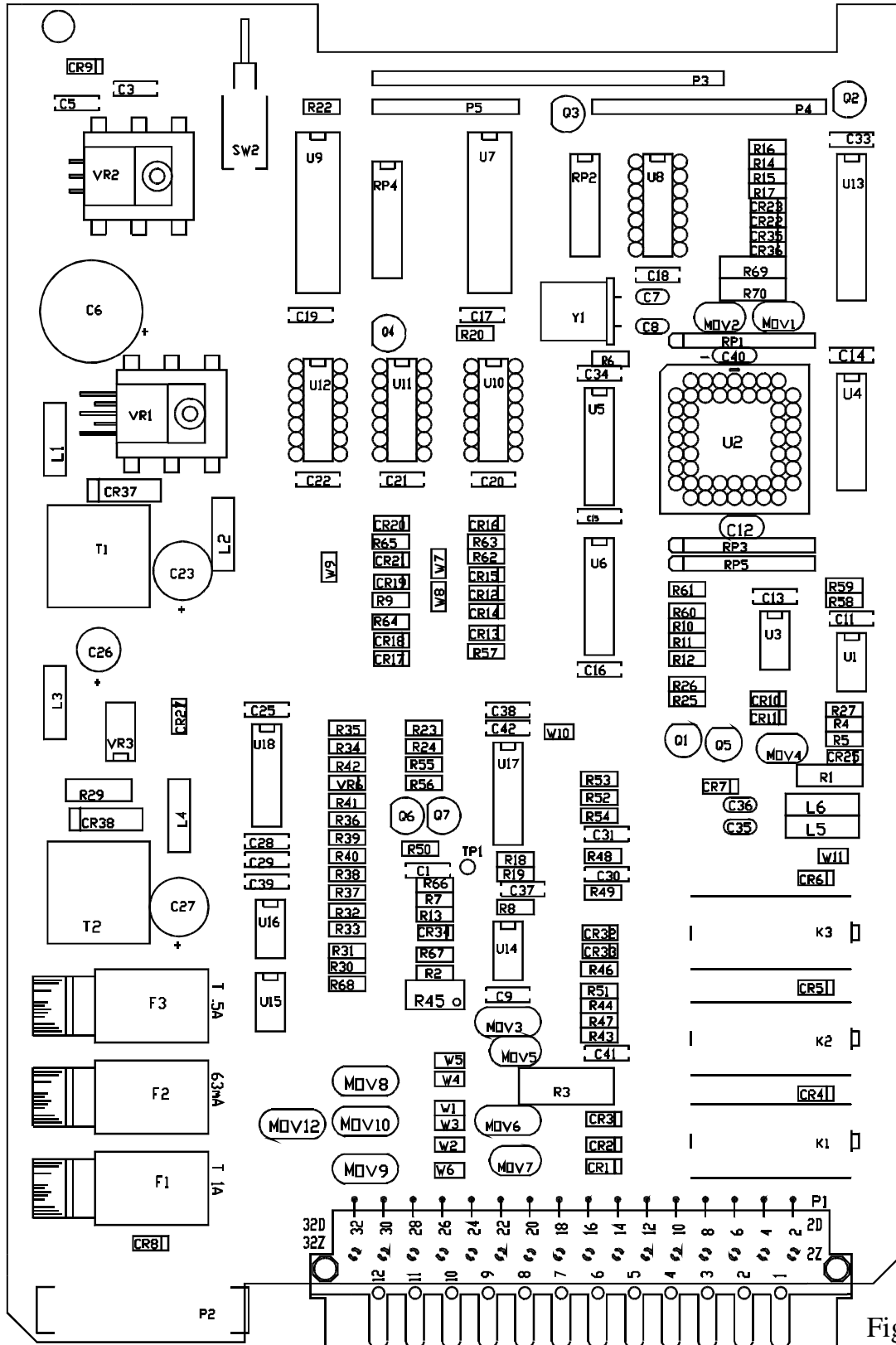

Figure 37



Engineering & Technical Drawings

(continued)

Reference Drawing # 11151-2

Circuit Card Assembly - Display Board

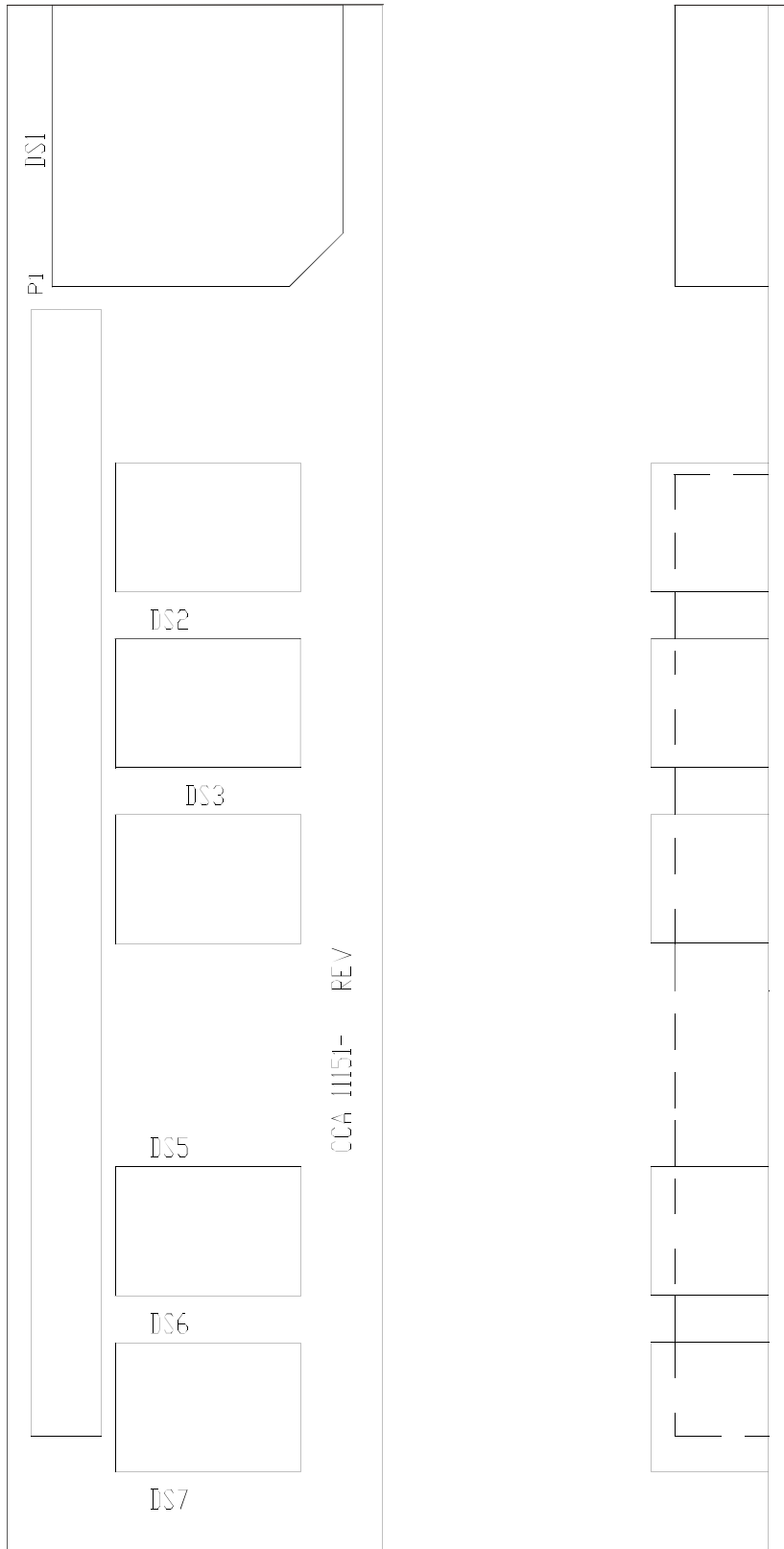
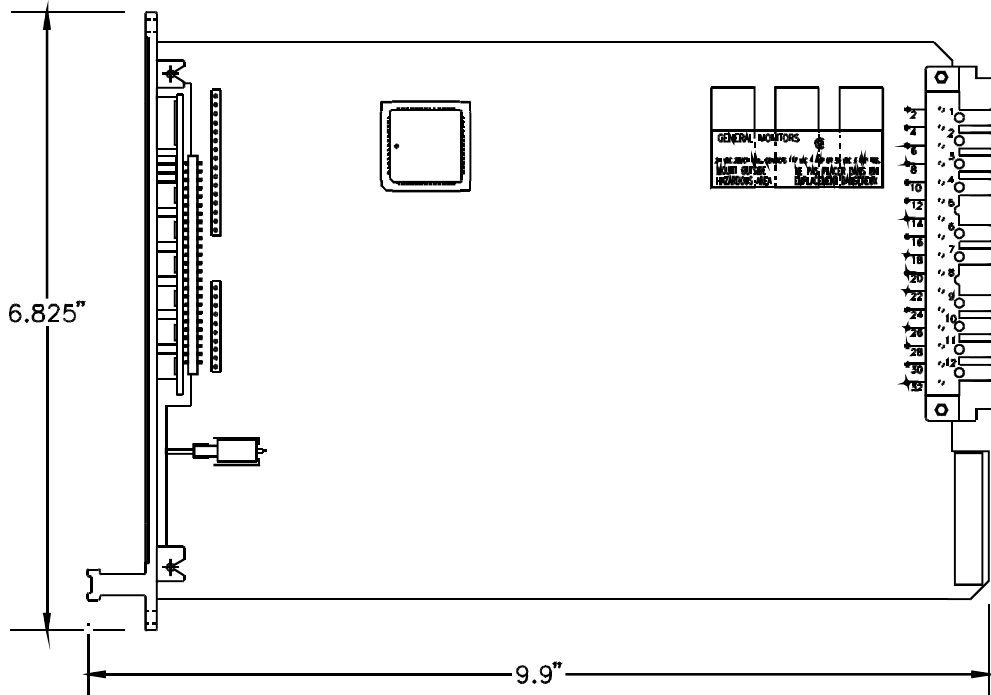

Figure 38



Engineering & Technical Drawings
(continued)

Reference Drawing # 11281
Outline & Terminal Connections



REAR CONNECTOR TERMINATIONS

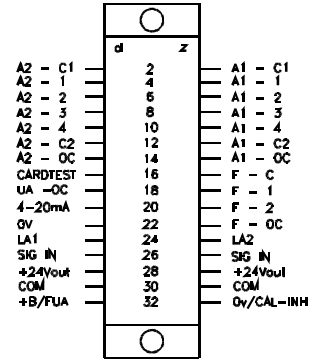

TA402A
RELAY CONTACTS

RELAY STATE	NORMALLY OPEN	NORMALLY CLOSED
ENERGIZED	CONTACT 1 & 4	CONTACT 2 & 3
DE-ENERGIZED	CONTACT 2 & 3	CONTACT 1 & 4

RELAY STATE	NORMALLY OPEN	NORMALLY CLOSED
ENERGIZED	CONTACT 1 & 4	CONTACT 2 & 3
DE-ENERGIZED	CONTACT 2 & 3	CONTACT 1 & 4

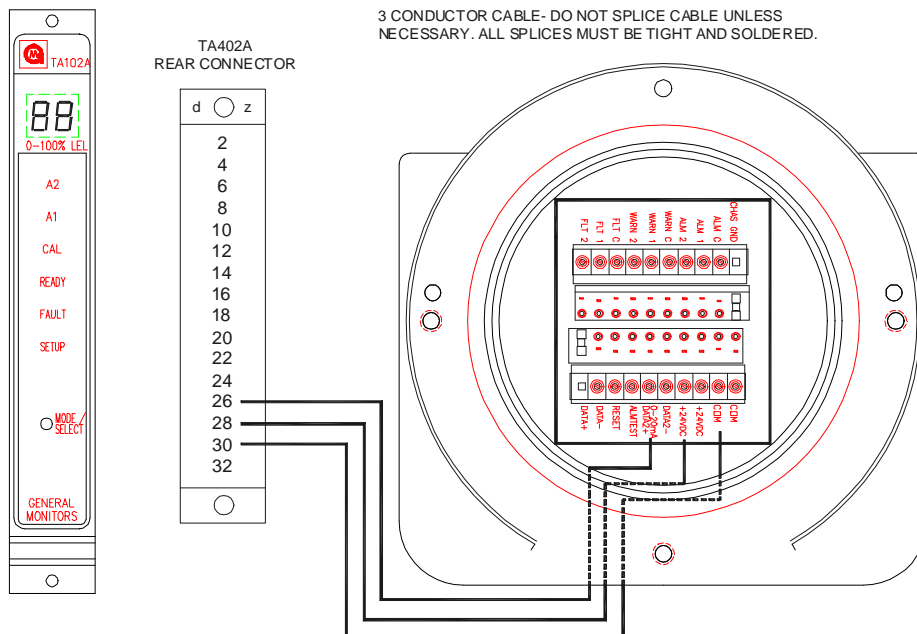

Figure 39



Engineering & Technical Drawings

Reference Drawing # 11280-1

(continued)

Final Assembly

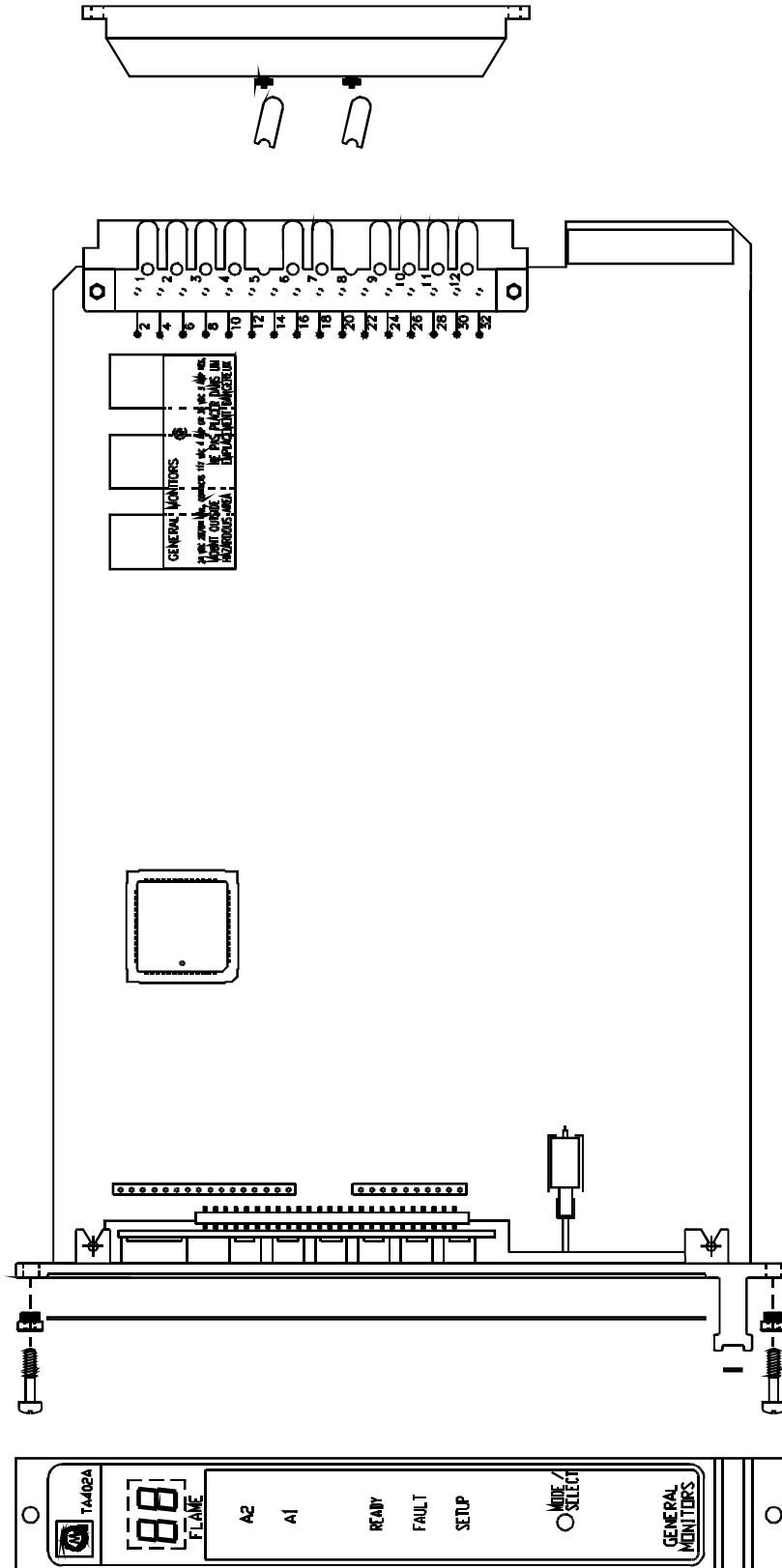

Figure 40



Ordering Information

The standard configuration for the Model

TA402A is:

TA402A - 3 2 1 - 1 00 - 0 6 3

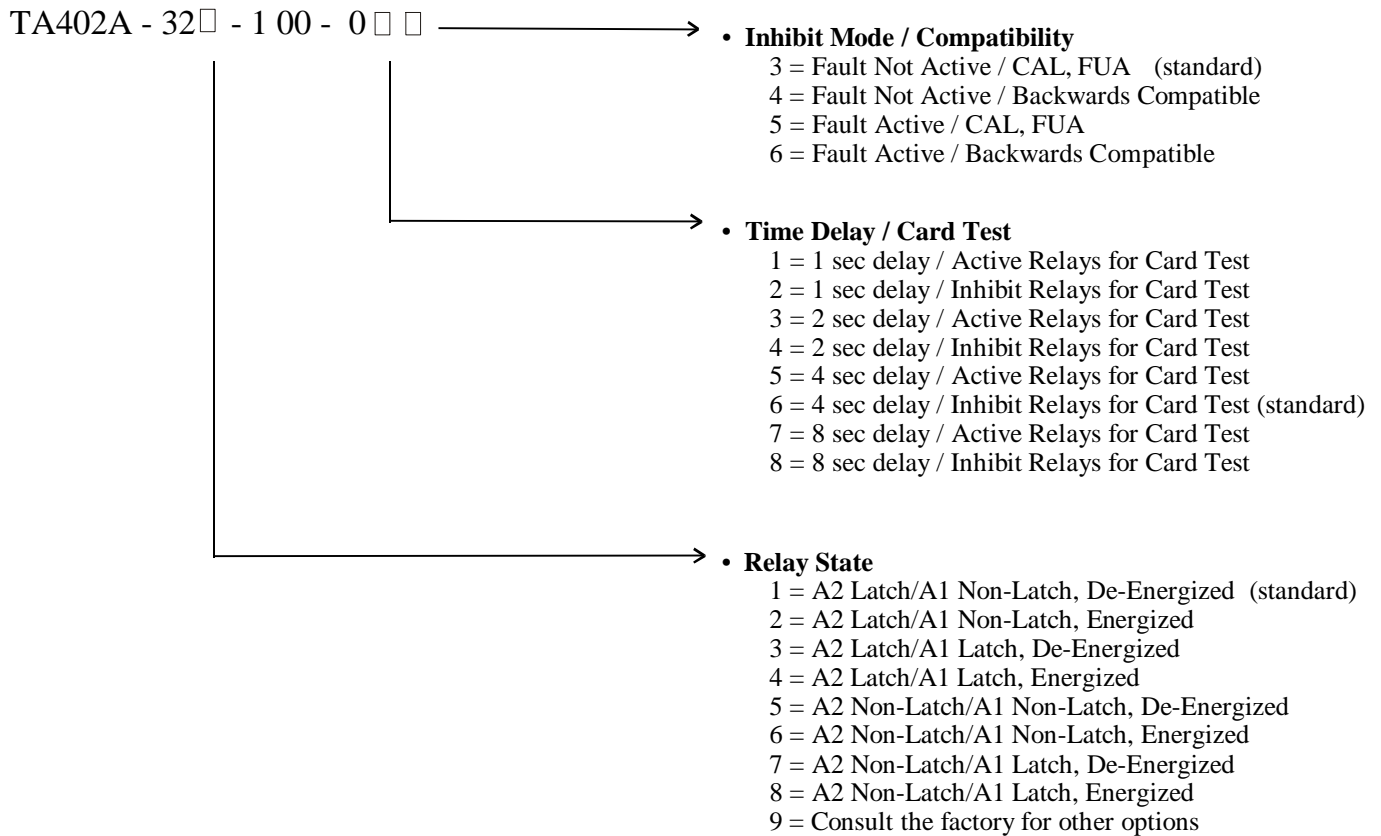



Zero Two Series Modules

Model 2602A

Zero Two Series Control Module
for Hydrogen Sulfide Gas
Applications

Model 4802A

Zero Two Series Control Module
for Combustible Gas
Applications

Model TA102A

Zero Two Series Trip Amplifier Module
for Combustible Gas
Applications

Model TA202A

Zero Two Series Trip Amplifier Module
for Hydrogen Sulfide Gas
Applications

Model TA402A

Zero Two Series Trip Amplifier Module
for Flame Detection
Applications

Model FM002A

Zero Two Series Facilities Module
Performs Common Functions
for Zero Two Systems

Model RL002

Zero Two Series Relay Module
Provides Extra Output Capacity
for Zero Two Systems

Model ZN002A

Zero Two Series Zone Control Module
Performs Zoning and Voting Functions
for Zero Two Systems

Model MD002

Zero Two Series Driver Card
for Monitoring / Driving High Current
Output Devices

Model IN042

Zero Two Series Four Zone Input Card
For Callpoints, Smoke & Thermal Detectors

Model PS002*

Zero Two Series Power Supply Module
for Zero Two Systems

* = For Use In Non-European Countries Only.



A

A1 Alarm	9
A2 Alarm	8
A2 Alarm Options.....	20, 21
AC	29
Alarm	
A1	9
A2	8
Accepting.....	14
Latched.....	15
Resetting.....	15
Ambient.....	29
Analog	29
Analog Output Signal	11
Applications	2
Applying Power	12
AWG.....	29

B

Benefits	1
----------------	---

C

Cable Parameters	3
CAL-IHN Open Collector.....	10
Canadian Standards Association	29
Card Test Options	23
Class I.....	29
Coding Strip	7
Female	7
Male.....	7
COM	29
Conduit.....	29
Connections	
A1 - OC	9
A1 Alarm Relay.....	9
A1 Mimic - OC.....	9
A2 Alarm - OC	8
A2 Alarm Relay.....	8
A2 Mimic - OC.....	8
Analog Minus	11
Analog Plus	11
Analog Signal	11
Card Test Switch	11
Fault - OC	9
Fault Relay	9
FUA - OC.....	9
Power	11
Control Module Installation	7
CSA.....	29

D

DC	29
DCS.....	29
Detector	
Connections	10
Type.....	3
Digital	29
Division 1	29
Drain Loop	29

E

EEPROM	29
Electrical Classification	3
Electromagnetic Interference	7
Engineering & Technical Drawings	31 through 38
Engineering Specifications	
TA402A	4
Zero Two Series	4

F

Facilities Module	15
Fault	9
Fault Option	
During Inhibit Mode.....	22
Fault Unaccept	9
Features	1
Features & Benefits	
Card Test	1, 11
LED Test	1
Live Insertion/Removal	1
Password Option.....	1
Setup Check Mode	1
Setup Mode.....	1
Flicker Rate	26, 29
FMRC	29
Functional Test	
SEE ALSO.....	Card Test

G

General Description	1
Glossary of Terms	29, 30
Group B.....	29
Group C.....	29
Group D	29

H

Halogen Free Solvent.....	29
Heat Build-up.....	7
Humidity Range	4



I

Inductive Loads9
 Input Power3
 Installation
 Applying Power12
 Control Module7
 Rear Terminal Connections7 through 11
 Detector Location Considerations12
 Upon Receipt of Equipment7
 Interfaces
 Display17
 Setup Check Mode17
 Setup Mode22, 23
 Introduction1, 2
 IR Radiation25, 26, 29

L

Latching29

M

mA29
 Maintenance
 Functional Test13
 General13
 Modes
 Inhibit17, 18, 20, 24
 Setup17 through 23
 Setup Check17 through 23
 Models
 2602A40
 4802A40
 FM002A40
 IN04240
 MD00240
 PS00240
 RL00240
 TA102A40
 TA202A40
 TA402A40
 ZN002A40
 Mounting Strip
 SEE ALSOCoding Strip
 mV29

N

NEC29

O

Open Collector
 A1 Alarm9, 13
 A1 Mimic9, 13
 A2 Alarm13
 A2 Mimic8, 13
 CAL-INH Output10
 Fault13
 Fault Unaccept (FUA)9, 13
 Rating3, 11, 13
 Unaccept (UA)10, 13
 Operation
 Accepting Alarm Conditions14
 CAL-INH Open Collector15
 Electrical Inputs13
 Electrical Outputs13, 14
 General Maintenance13
 Resetting Latched Alarms15
 Ordering Information39

P

Password Option19, 23
 PCB29
 PLC29

R

Rear Terminal Connections7, 9, 10, 11
 Receipt of Equipment7
 Relay
 A1 Alarm13
 A1 Common9
 A1 Contact9
 A2 Alarm13
 A2 Contact8
 A2, Common8
 Contact Rating3, 9, 13
 De-Energized A1 Alarm9
 De-Energized A2 Alarm8
 Energized A1 Alarm9
 Energized A2 Alarm8
 Fault13
 Fault Contact9
 NC Contact, A1 Alarm9
 NC Contact, A2 Alarm8
 NO Contact, A1 Alarm9
 NO Contact, A2 Alarm8
 Protection Circuits9
 RFI29

**S**

Setup Check Mode	17
Specifications	
TA402A Control Module	4
Cable Parameters	3
Electrical Classification	3
Electrical Specifications	3
Engineering Specifications	4
Environmental Specifications	4
Height	3
Input Power Requirement	3
Length	3
Mechanical Specifications	3
Open Collector Rating	3
Operating Humidity Range	4
Operating Temperature Range	4
Relay Contact Rating	3
Response Time	3
Detector Type	3
Storage Temperature Range	4
System Specifications	3
Weight	3
Width	3

T

TB	30
Temperature	
Operating Range	4
Storage Range	4

Terminal Block	
Designations	8
Operation	8
Terminal Connections, Rear	8
Terms, Glossary	29, 30
Test	
Card Test	1, 11
LED Test	1

U

Unaccept Output	10
User Interfaces, Types	17
Ultraviolet (UV)	25, 26, 27, 30

W

Warnings	
Backwards Compatibility	i
Detector/Module Compatibility	i
Electro-Static Damage	i, 8
Product Identification	i
Safety	i
Wire Strip Length	8

Z

Zero Two Series Modules	40
-------------------------------	----

