

THIS DOCUMENT IS THE PROPERTY OF SENSICENT LIMITED AND CONTAINS INFORMATION WHICH IS PROPRIETARY. THIS INFORMATION IS TO BE HELD IN CONFIDENCE. NO DISCLOSURE OR OTHER USE OF THIS DOCUMENT IS TO BE MADE WITHOUT THE PRIOR WRITTEN CONSENT OF SENSICENT LIMITED.

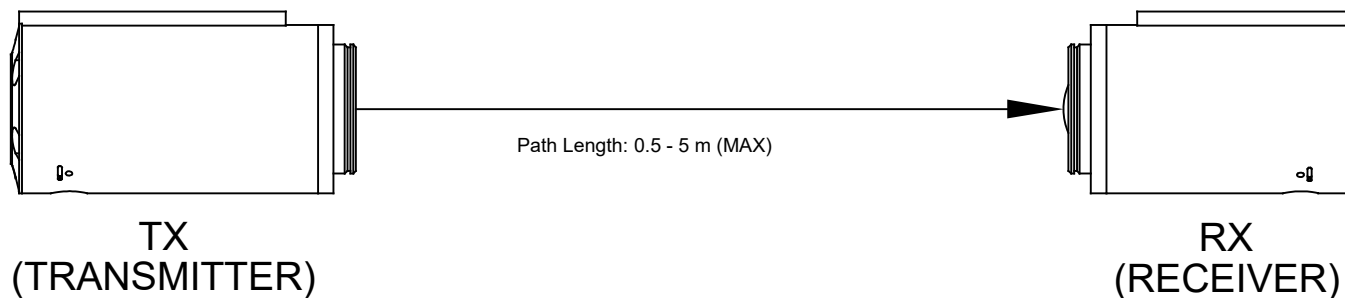
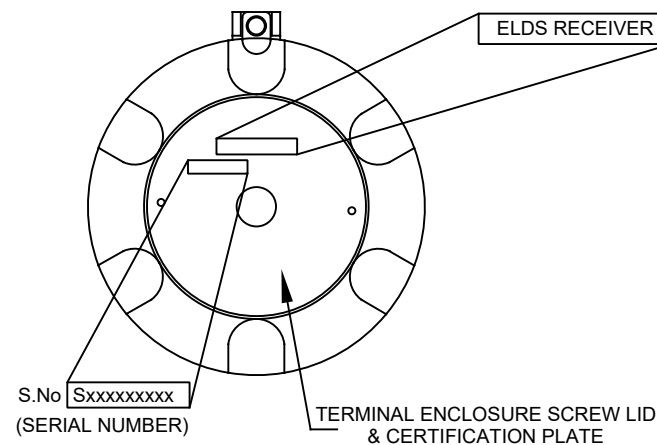
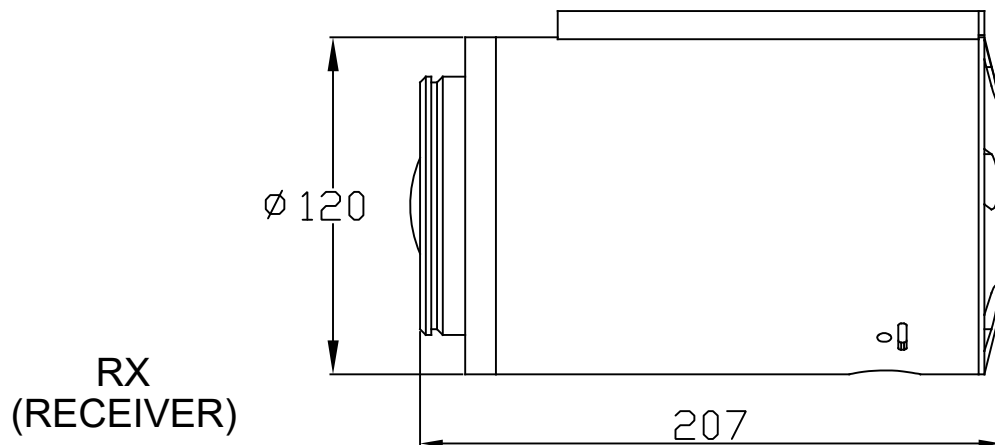
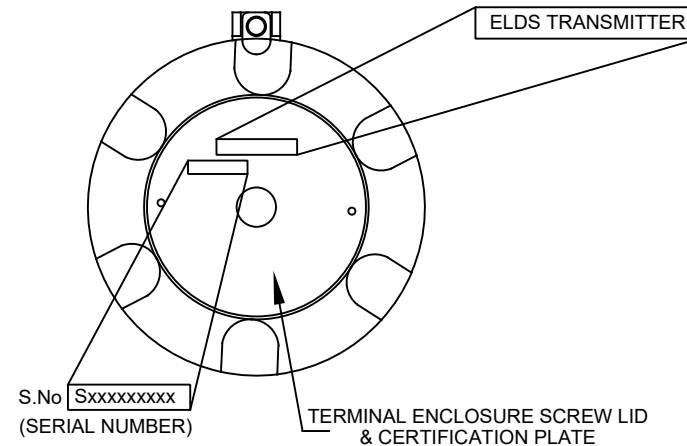
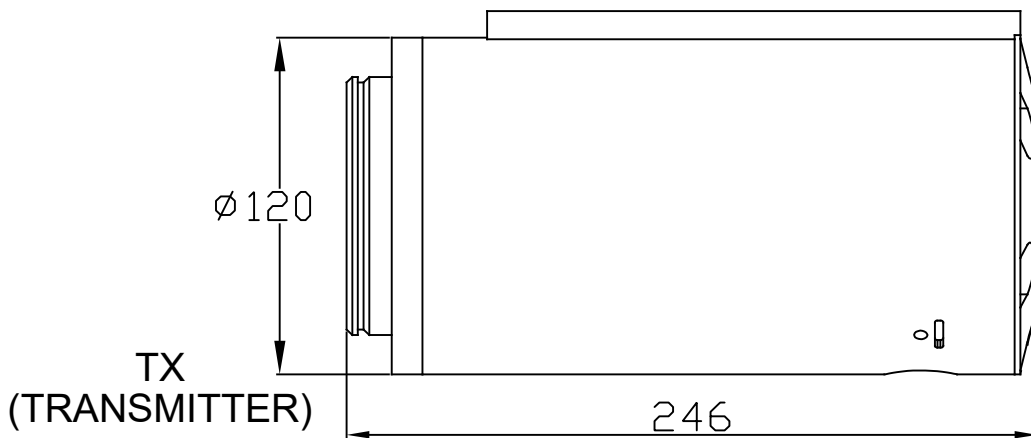

notes:

Vendor/Supplier Name:	Sensicent		
Vendor/Supplier Doc. No.:	Page 1 of 6	Rev Date:	Rev No.:
Vendor No.:		1/5/2014	1
Document title:	UNIT IDENTIFICATION / GENERAL ARRANGMENT DRAWING FOR ELDS 1000/2000 GAS DETECTORS.		
Equipment Description:	VZ (Across Vent) ELDS GAS DETECTORS		
Paper Size A3	Scale: NTS		
ALL MEASUREMENTS IN mm UNLESS OTHERWISE STATED			

SIDE VIEW

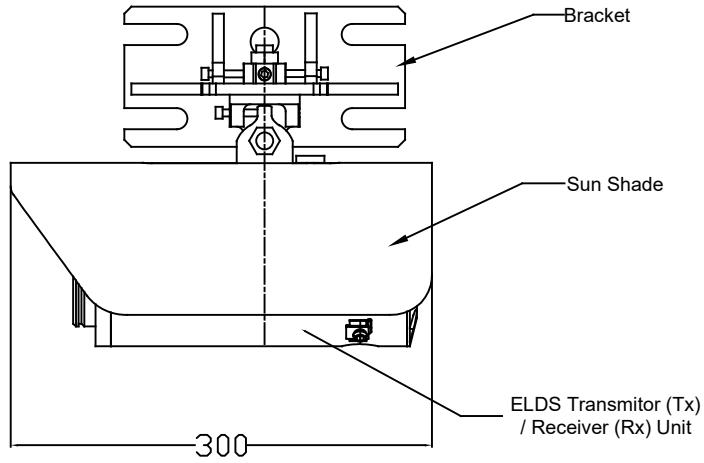

FRONT VIEW

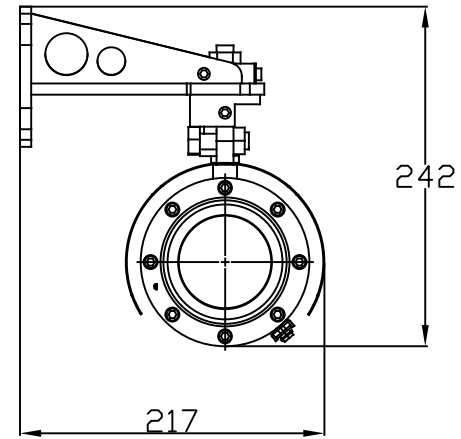

ITEM	WEIGHT (Kg)
Bracket	3.05
Sunshade	1.0
Rx (Unit Only)	7.4
Tx (Unit Only)	8.2
Rx (Complete)	11.45
Tx (Complete)	12.24

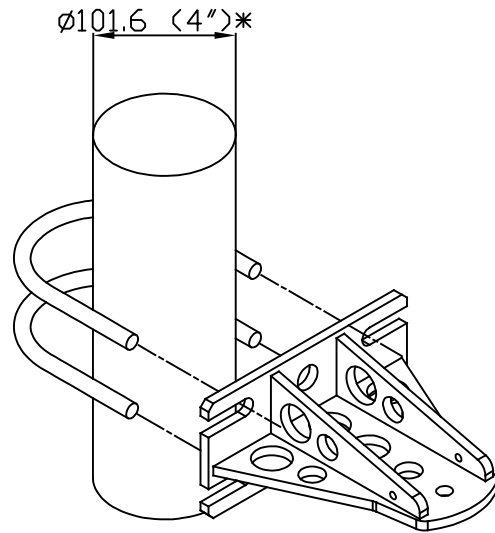

PLAN VIEW

(underside)

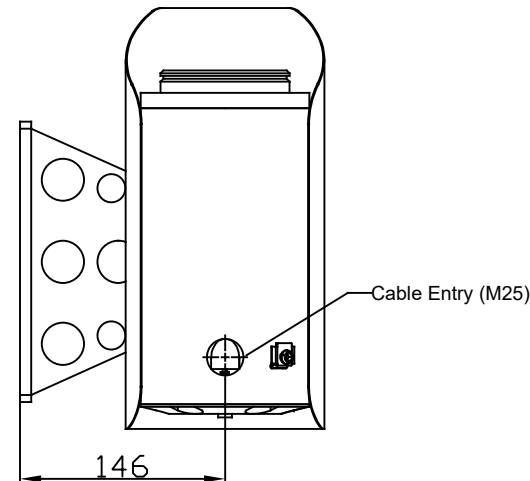

* 4" = nominal Size. Capable of upto 6"

Illustrations of Senscient ELDS Series 2000 Trasmiter Unit (Tx) - For Reference only. A Senscient ELDS Series 2000 system is made up of a Transmitter and Receiver (Receiver not shown)

NOTES:

Vendor/Supplier Name:	Senscient		
Vendor/Supplier Doc. No.:	Page 2 of 6	Rev Date:	Rev No.:
Vendor No.:		1/5/2014	1
Document title:	GENERAL ARRANGMENT DRAWING FOR ELDS 1000/2000 GAS DETECTOR		
Equipment Description:	VZ (Across Vent) ELDS GAS DETECTORS		
Paper Size A3	Scale: NTS		
ALL MEASUREMENTS IN mm UNLESS OTHERWISE STATED			

THIS DOCUMENT IS THE PROPERTY OF SENSICIENT LIMITED AND CONTAINS INFORMATION WHICH IS PROPRIETARY. THIS INFORMATION IS TO BE HELD IN CONFIDENCE. NO DISCLOSURE OR OTHER USE OF THIS DOCUMENT IS TO BE MADE WITHOUT THE PRIOR WRITTEN CONSENT OF SENSICIENT LIMITED.

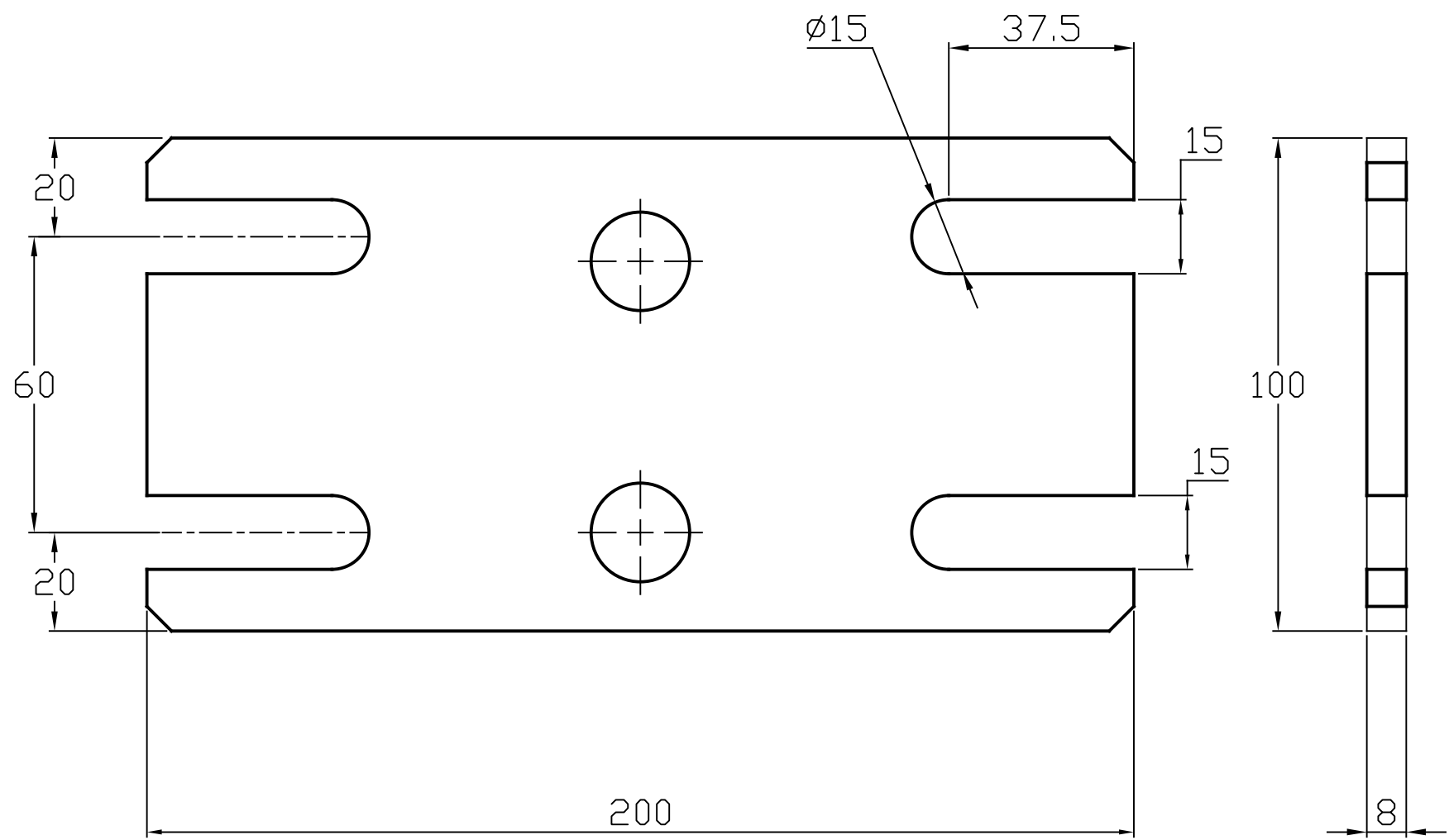

NOTES:

Vendor/Supplier Name:	Sensicient		
Vendor/Supplier Doc. No.:	Page 3 of 6	Rev Date:	Rev No.:
Vendor No.:		1/5/2014	1
Document title:	GENERAL ARRANGMENT DRAWING FOR ELDS 1000/2000 GAS DETECTOR MOUNTING BRACKET DETAILS		
Equipment Description:	VZ (Across Vent) ELDS GAS DETECTORS		
Paper Size A3	Scale: 1:1 - When printed from original document.		
ALL MEASUREMENTS IN mm UNLESS OTHERWISE STATED			

THIS DOCUMENT IS THE PROPERTY OF Senscient Ltd AND CONTAINS INFORMATION WHICH IS PROPRIETARY. THIS INFORMATION IS TO BE HELD IN CONFIDENCE. NO DISCLOSURE OR OTHER USE OF THIS DOCUMENT IS TO BE MADE WITHOUT THE PRIOR WRITTEN CONSENT OF Senscient Ltd.

ELDS Transmitter Connections

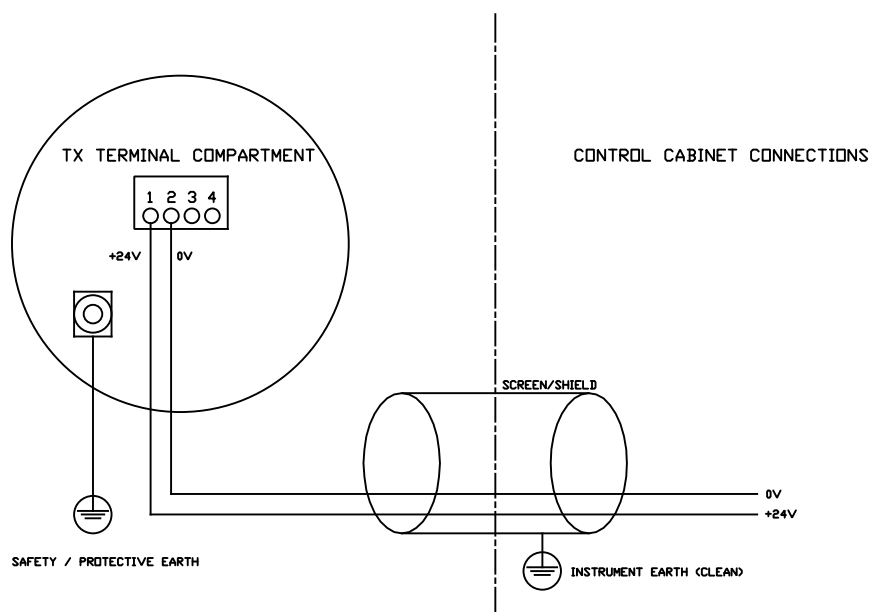

NOTES:

ELDS Receiver Connections (Current Sink)

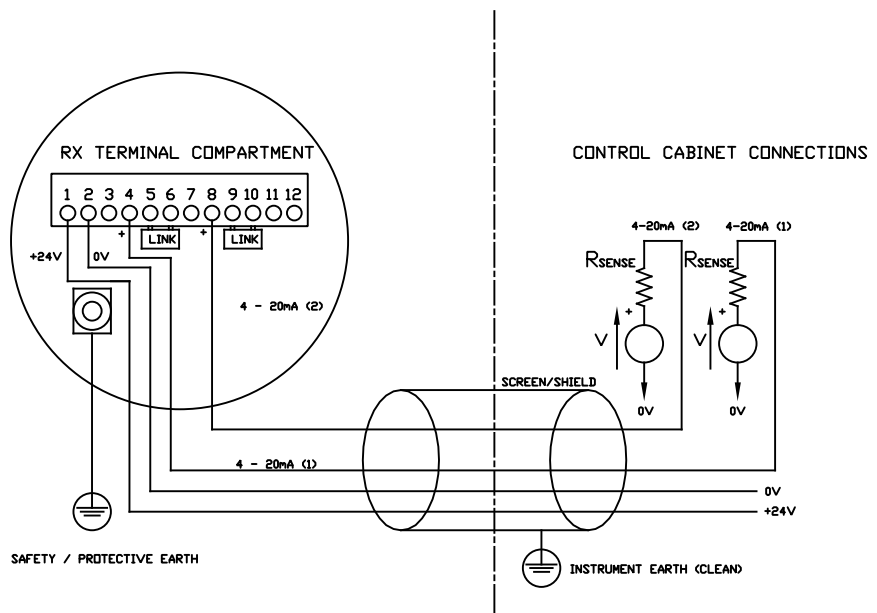

Vendor/Supplier Name:	Senscient		
Vendor/Supplier Doc. No:	Page 4 of 6	Rev Date	Rev No.
Drawing No.:	01-01-2556-D	21/3/17	1
Document title:	WIRING - CURRENT SINK GENERAL ARRANGMENT DRAWING FOR ELDS 1000/2000		
Equipment Description:	VZ (Across Vent) ELDS GAS DETECTORS		
Paper Size A3	Scale: NTS		
ALL MEASUREMENTS IN mm UNLESS OTHERWISE STATED			

THIS DOCUMENT IS THE PROPERTY OF Senscient Ltd. AND CONTAINS INFORMATION WHICH IS PROPRIETARY. THIS INFORMATION IS TO BE HELD IN CONFIDENCE. NO DISCLOSURE OR OTHER USE OF THIS DOCUMENT IS TO BE MADE WITHOUT THE PRIOR WRITTEN CONSENT OF Senscient Ltd.

ELDS Transmitter Connections

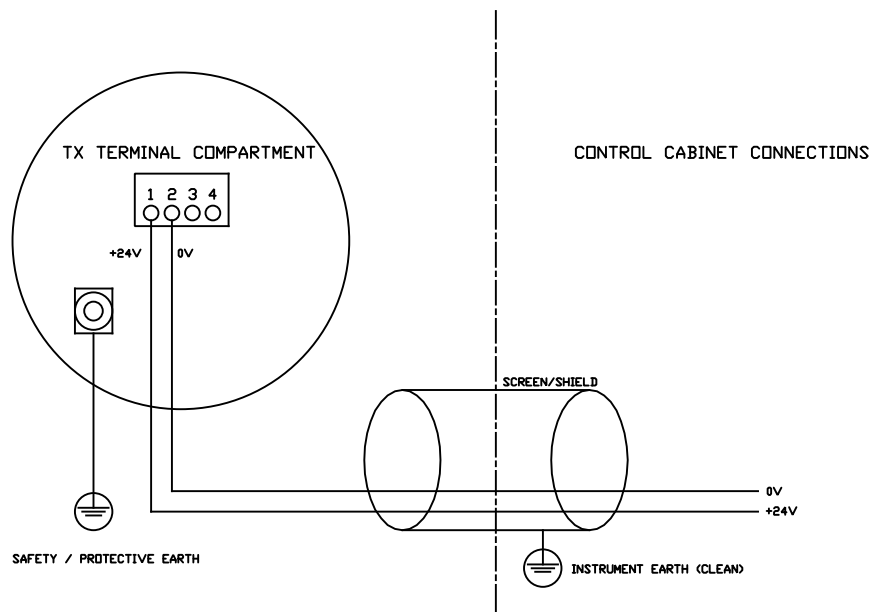

ELDS Receiver Connections (Current Source)

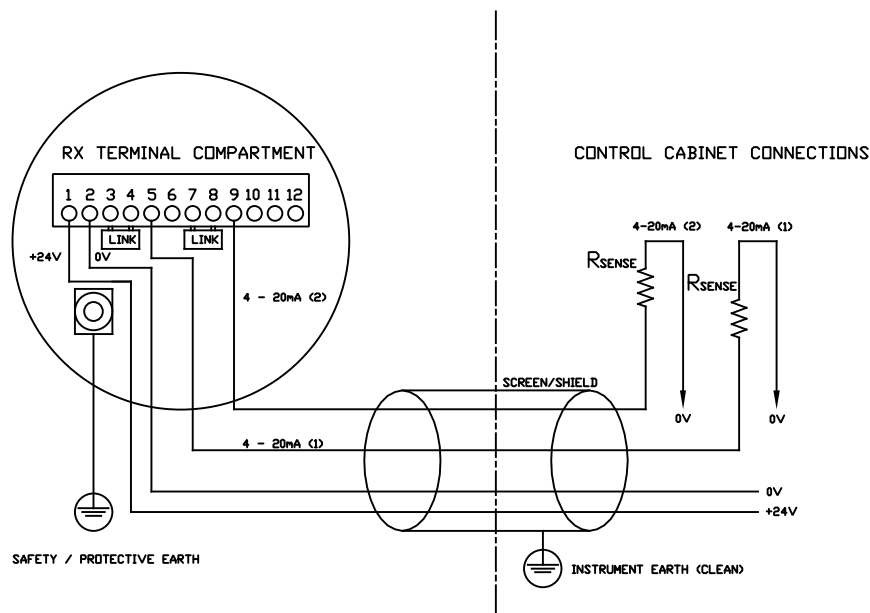

NOTES:

Vendor/Supplier Name:	Senscient		
Vendor/Supplier Doc. No.:	Page 5 of 6	Rev Date:	Rev No.:
Drawing No.:	01-01-2556-D	21/3/17	1
Document title:	WIRING - CURRENT SOURCE GENERAL ARRANGMENT DRAWING FOR ELDS 1000/2000		
Equipment Description:	VZ (Across Vent) ELDS GAS DETECTORS		
Paper Size A3	Scale: NTS		
ALL MEASUREMENTS IN mm UNLESS OTHERWISE STATED			

THIS DOCUMENT IS THE PROPERTY OF Senscient Ltd. AND CONTAINS INFORMATION WHICH IS PROPRIETARY. THIS INFORMATION IS TO BE HELD IN CONFIDENCE. NO DISCLOSURE OR OTHER USE OF THIS DOCUMENT IS TO BE MADE WITHOUT THE PRIOR WRITTEN CONSENT OF Senscient Ltd.

ELDS Transmitter Connections

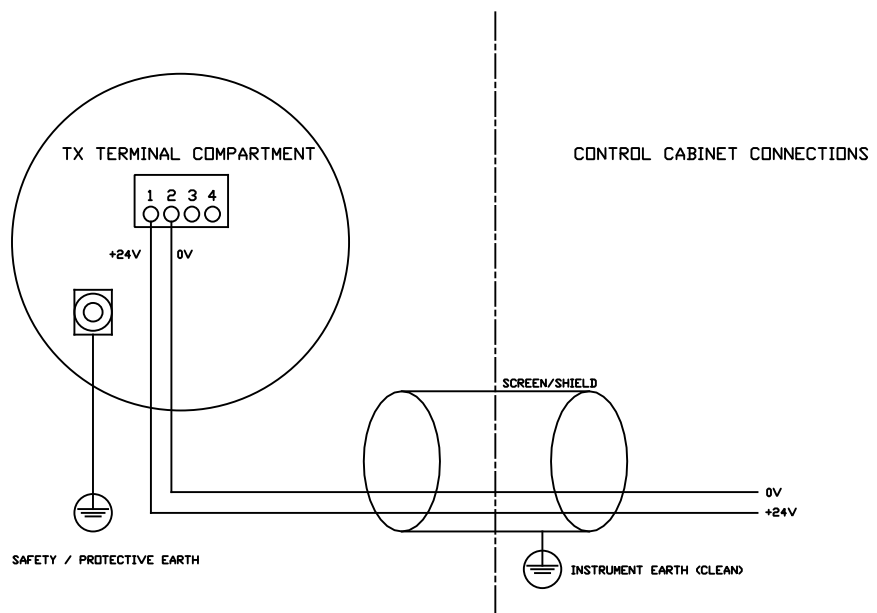

NOTES:

ELDS Receiver Connections (Isolated Output)

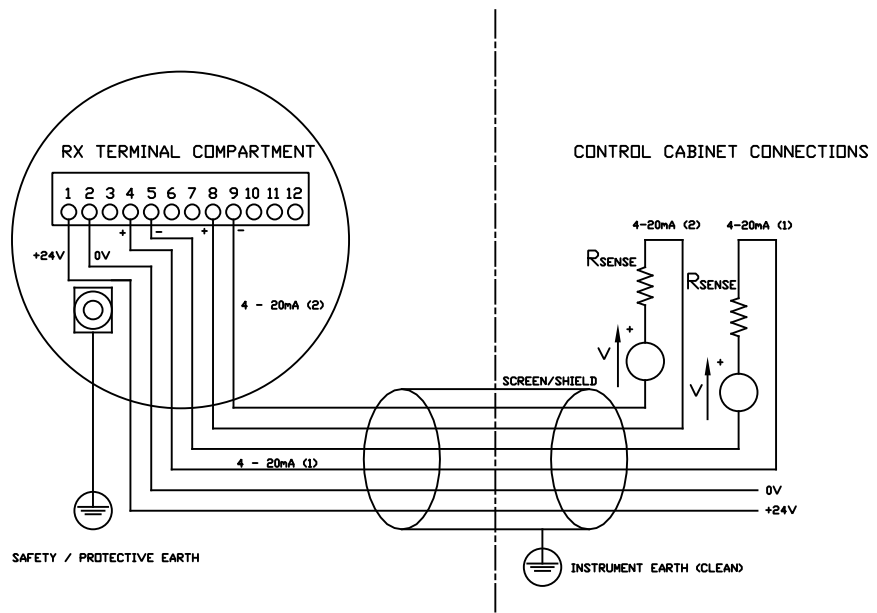

Vendor/Supplier Name:	Senscient		
Vendor/Supplier Doc. No.:	Page 6 of 6	Rev Date:	Rev No.:
Drawing No.:	01-01-2556-D	21/3/17	1
Document title:	WIRING - ISOLATED OUTPUT GENERAL ARRANGMENT DRAWING FOR ELDS 1000/2000		
Equipment Description:	VZ (Open Path) ELDS GAS DETECTORS		
Paper Size A3	Scale: NTS		
ALL MEASUREMENTS IN mm UNLESS OTHERWISE STATED			