

THIS DOCUMENT IS THE PROPERTY OF ABU DHABI GAS DEVELOPMENT LIMITED AND CONTAINS INFORMATION WHICH IS PROPRIETARY. THIS INFORMATION IS TO BE HELD IN CONFIDENCE. NO DISCLOSURE OR OTHER USE OF THIS DOCUMENT IS TO BE MADE WITHOUT THE PRIOR WRITTEN CONSENT ABU DHABI GAS DEVELOPMENT LIMITED.

FRONT VIEW

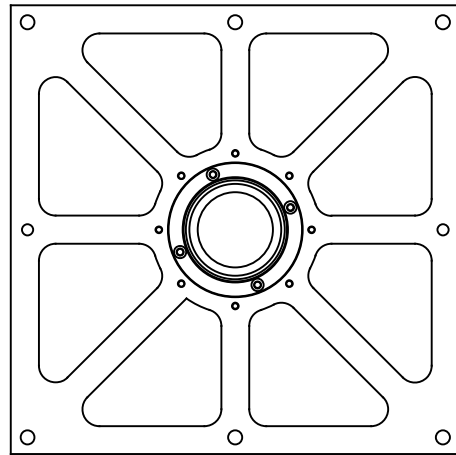

SIDE VIEW

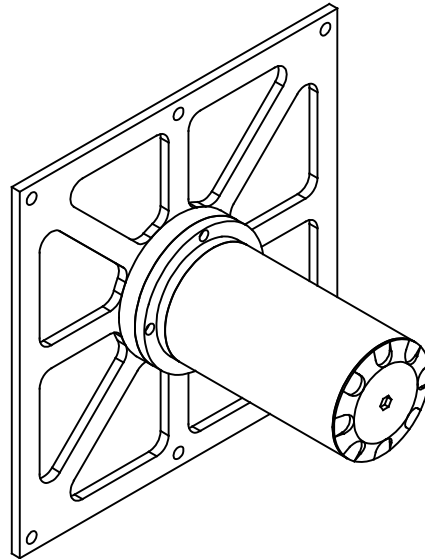
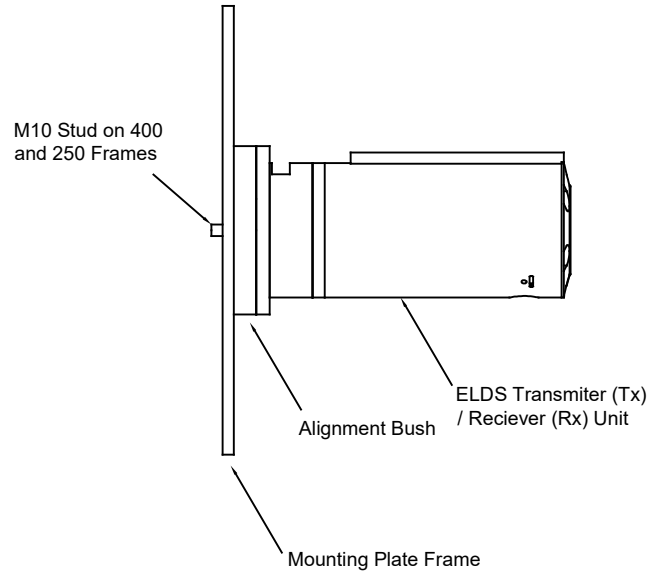

ITEM	WEIGHT (Kg)
Mounting Plate 400	5.65
Mounting Plate 250	2.75
Mounting Plate 180	1.65
Alignment Bush	0.125
Rx unit	7.4
Tx Unit	8.2
Rx (complete with 400 plate)	11.45
Tx (complete with 400 plate)	12.24

notes:

Illustrations of Senscient ELDS Series 2000 Transmitter Unit (Tx) - For Reference Only. A Senscient ELDS Series 2000 system is made up of a Transmitter and Receiver (Receiver not shown)

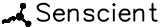
Vendor/Supplier Name:			
Vendor/Supplier Doc. No.:	Page 1 of 6	Rev Date	Rev No.
Vendor No.:		9/12/14	2
Document title:	GENERAL ARRANGMENT DRAWING FOR ELDS XD / XC GAS DETECTOR.		
Equipment Description:	XD / XC ELDS GAS DETECTORS		
Paper Size A3	Scale: NTS		
ALL MEASUREMENTS IN mm UNLESS OTHERWISE STATED			

THIS DOCUMENT IS THE PROPERTY OF ABU DHABI GAS DEVELOPMENT LIMITED AND CONTAINS INFORMATION WHICH IS PROPRIETARY. THIS INFORMATION IS TO BE HELD IN CONFIDENCE. NO DISCLOSURE OR OTHER USE OF THIS DOCUMENT IS TO BE MADE WITHOUT THE PRIOR WRITTEN CONSENT ABU DHABI GAS DEVELOPMENT LIMITED.

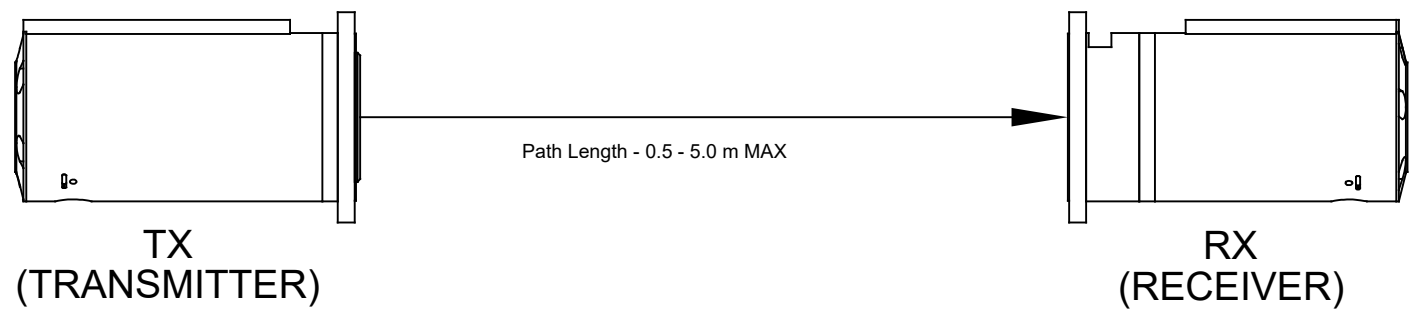
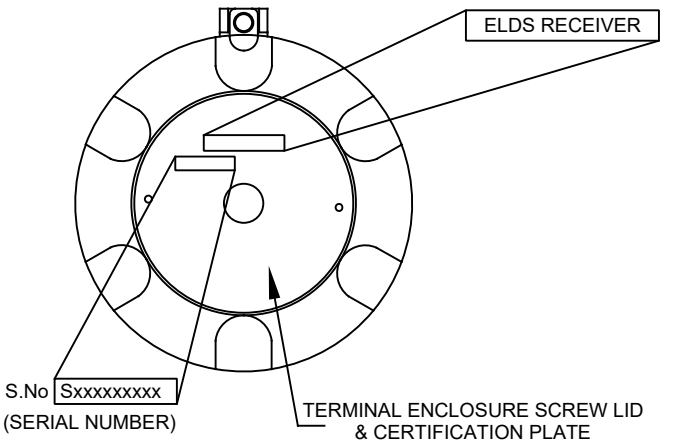
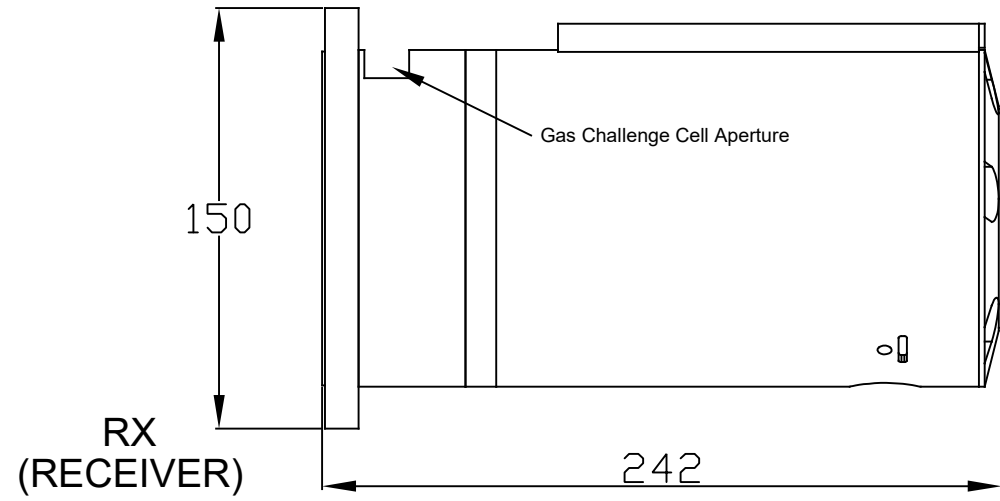
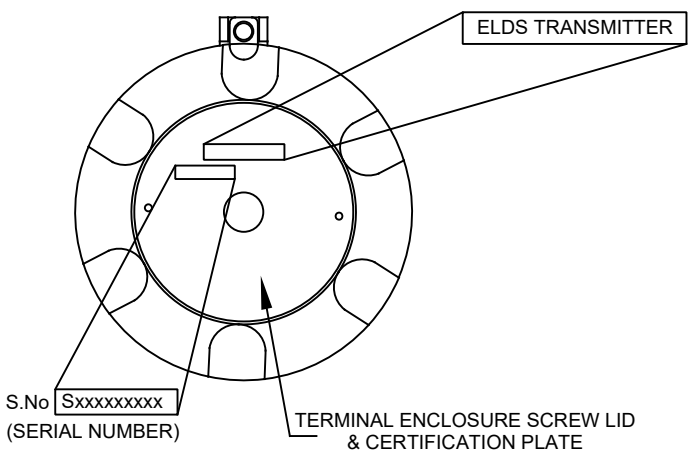
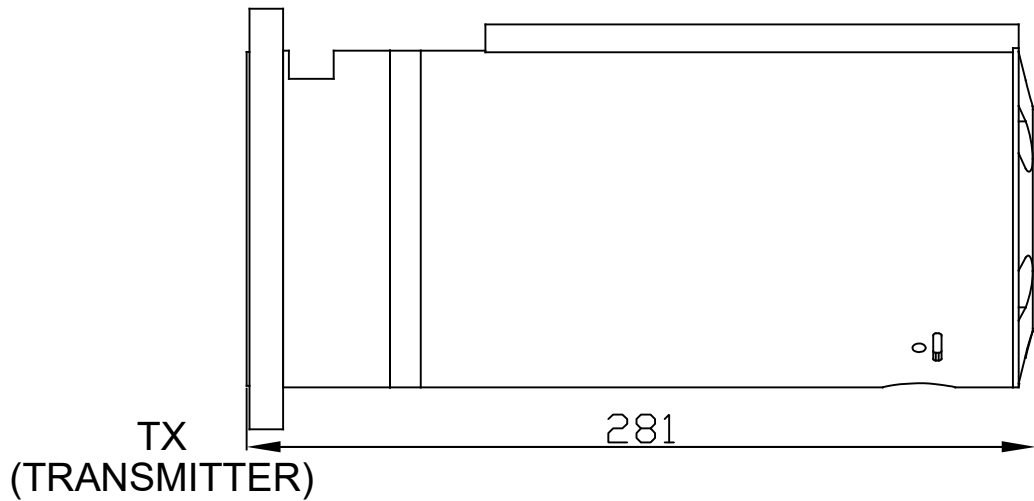

notes:

Vendor/Supplier Name:	Senscient		
Vendor/Supplier Doc. No.:	Page 2 of 6	Rev Date:	Rev No.:
Vendor No.:		9/12/14	2
Document title:	UNIT IDENTIFICATION / GENERAL ARRANGMENT DRAWING FOR ELDS XD / XC GAS DETECTORS.		
Equipment Description:	XD / XC ELDS GAS DETECTORS		
Paper Size A3	Scale: NTS		
ALL MEASUREMENTS IN mm UNLESS OTHERWISE STATED			

THIS DOCUMENT IS THE PROPERTY OF ABU DHABI GAS DEVELOPMENT LIMITED AND CONTAINS INFORMATION WHICH IS PROPRIETARY. THIS INFORMATION IS TO BE HELD IN CONFIDENCE. NO DISCLOSURE OR OTHER USE OF THIS DOCUMENT IS TO BE MADE WITHOUT THE PRIOR WRITTEN CONSENT OF ABU DHABI GAS DEVELOPMENT LIMITED.

M10 Mounting Studs
(not 180 - Retro Fit)

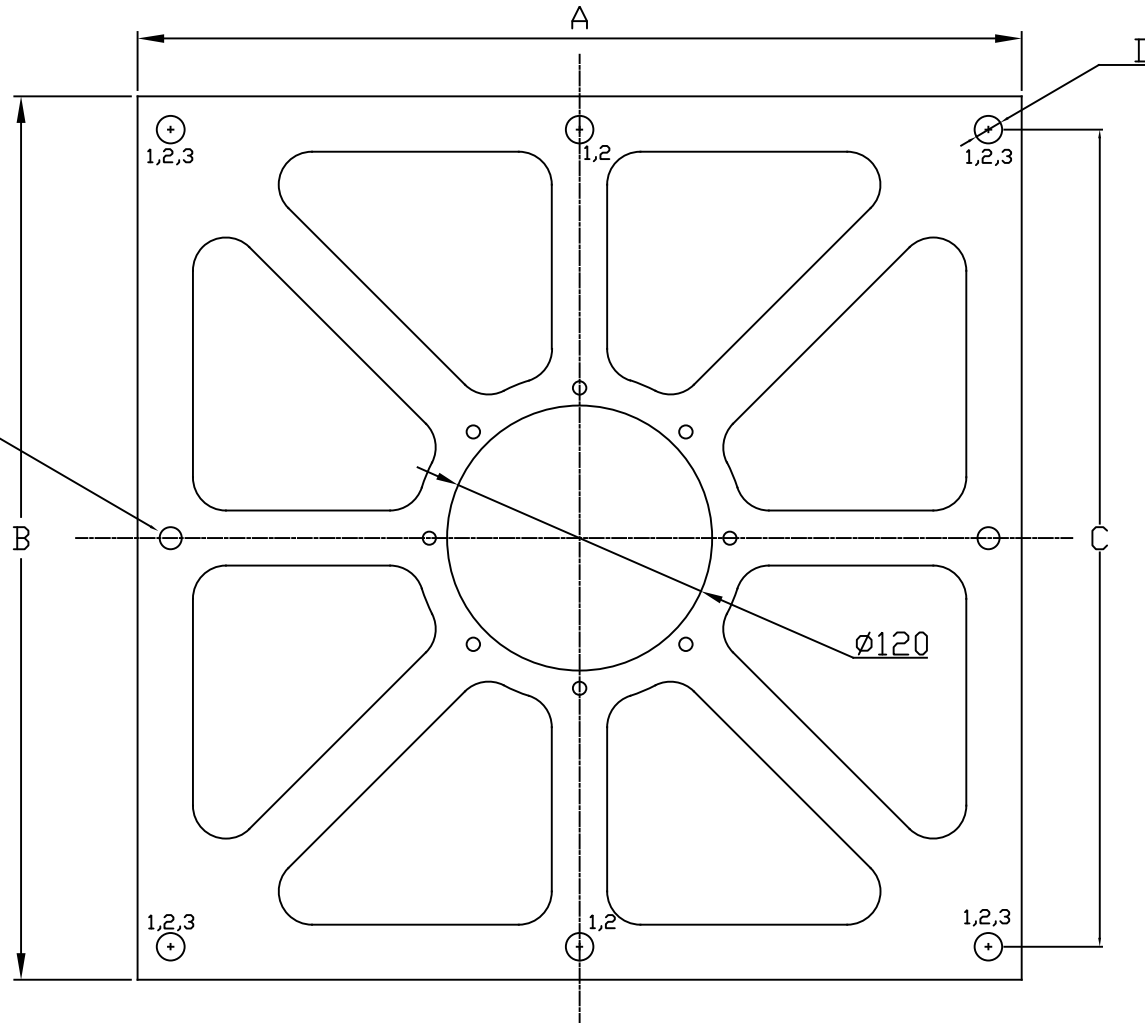

Image shows High Temperature Mounting Plate (400x400)

Mounting Plate Specifications - SS 314

Type	Sales Code	Width (A)	Height (B)	Hole Cntr (C)	Hole Dia (D)	Material Thickness	Weight Kg / Ea	Stud Length
1. Standard 400	A-5041-0	400	400	370	12.5	10	5.65	10
2. Micro 250	A-5042-0	250	250	230	10.5	10	2.75	20
3. Retro Fit 180	A-5043-0	180	180	162	9.0	10	1.65	n/a

NOTES:

Vendor/Supplier Name:	Senscient		
Vendor/Supplier Doc. No.:	Page 3 of 6	Rev Date:	Rev No.:
Vendor No.:		25/2/15	3
Document title:	GENERAL ARRANGMENT DRAWING FOR ELDS XD / XC GAS DETECTOR: Mounting Plate Details.		
Equipment Description:	XD / XC ELDS GAS DETECTORS		
Paper Size A3	Scale: 1:1 - When printed from original document.		
ALL MEASUREMENTS IN mm UNLESS OTHERWISE STATED			

THIS DOCUMENT IS THE PROPERTY OF Senscient Ltd AND CONTAINS INFORMATION WHICH IS PROPRIETARY. THIS INFORMATION IS TO BE HELD IN CONFIDENCE. NO DISCLOSURE OR OTHER USE OF THIS DOCUMENT IS TO BE MADE WITHOUT THE PRIOR WRITTEN CONSENT OF Senscient Ltd.

ELDS Transmitter Connections

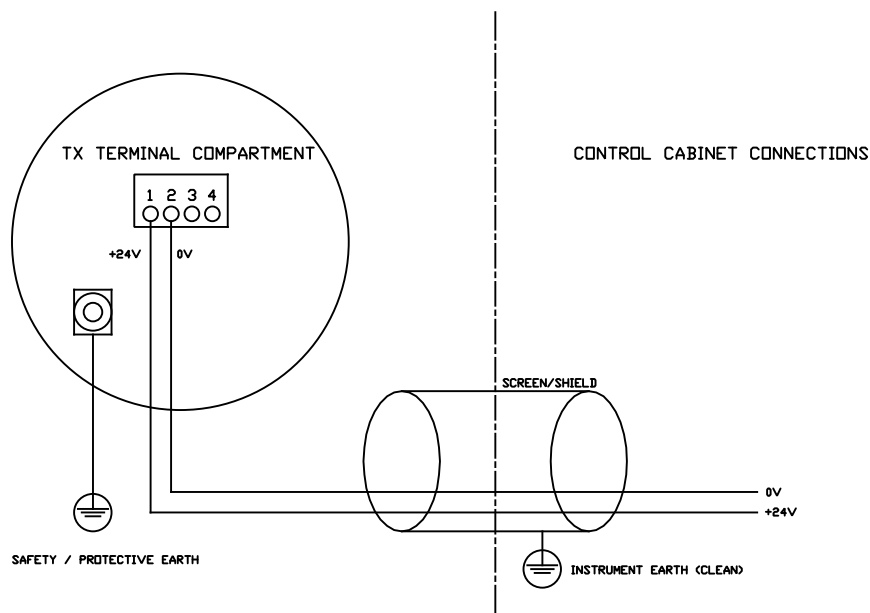

ELDS Receiver Connections (Current Sink)

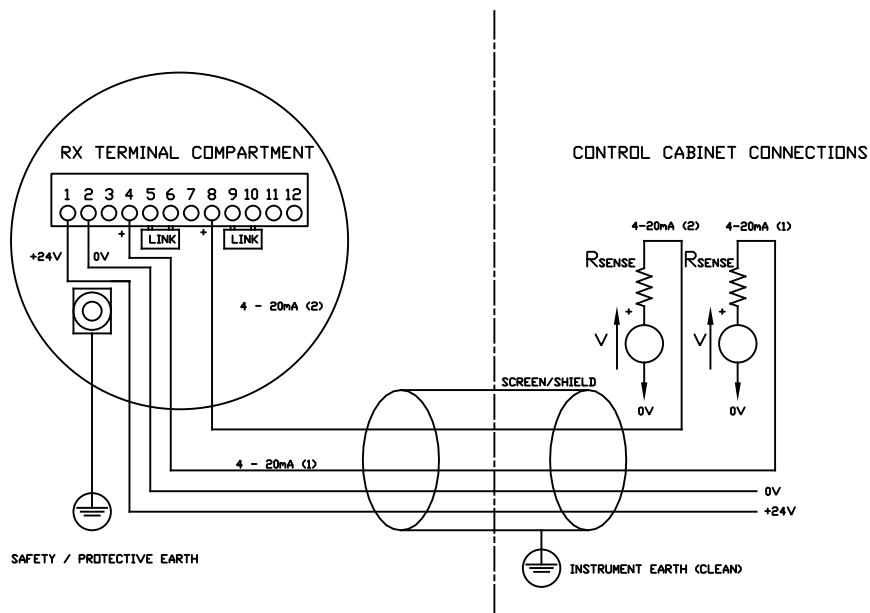

NOTES:

Vendor/Supplier Name:	Senscient		
Vendor/Supplier Doc. No.:	Page 4 of 6	Rev Date:	Rev No.:
Drawing No.:	01-01-2556-D	21/3/17	1
Document title:	WIRING - CURRENT SINK GENERAL ARRANGMENT DRAWING FOR ELDS 1000/2000		
Equipment Description:	XD / XC ELDS GAS DETECTORS		
Paper Size A3:	Scale: NTS		
ALL MEASUREMENTS IN mm UNLESS OTHERWISE STATED			

THIS DOCUMENT IS THE PROPERTY OF Senscient Ltd. AND CONTAINS INFORMATION WHICH IS PROPRIETARY. THIS INFORMATION IS TO BE HELD IN CONFIDENCE. NO DISCLOSURE OR OTHER USE OF THIS DOCUMENT IS TO BE MADE WITHOUT THE PRIOR WRITTEN CONSENT OF Senscient Ltd.

ELDS Transmitter Connections

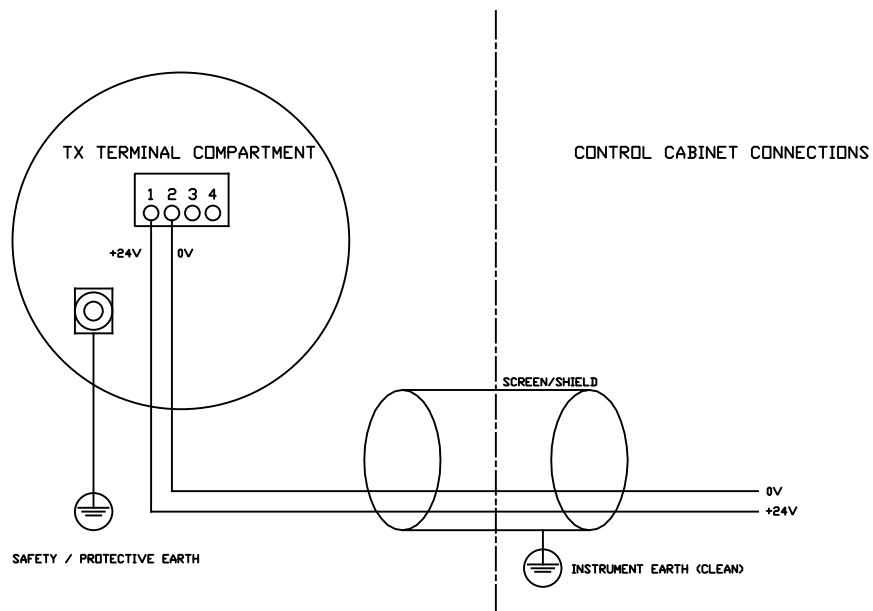

NOTES:

ELDS Receiver Connections (Current Source)

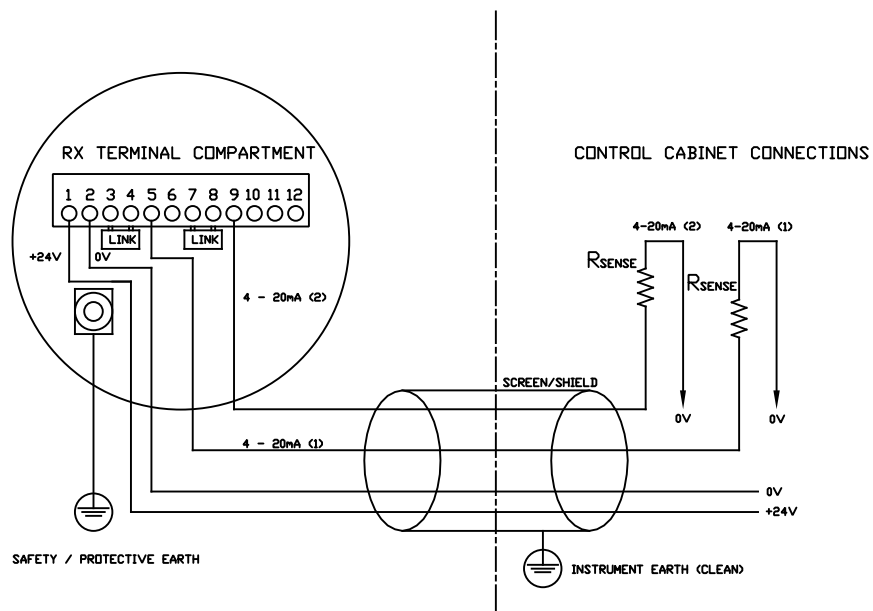

Vendor/Supplier Name:	Senscient		
Vendor/Supplier Doc. No.:	Page 5 of 6	Rev Date:	Rev No.:
Drawing No.:	01-01-2556-D	21/3/17	1
Document title:	WIRING - CURRENT SOURCE GENERAL ARRANGMENT DRAWING FOR ELDS 1000/2000		
Equipment Description:	XD / XC ELDS GAS DETECTORS		
Paper Size A3	Scale: NTS		
ALL MEASUREMENTS IN mm UNLESS OTHERWISE STATED			

THIS DOCUMENT IS THE PROPERTY OF Senscient Ltd. AND CONTAINS INFORMATION WHICH IS PROPRIETARY. THIS INFORMATION IS TO BE HELD IN CONFIDENCE. NO DISCLOSURE OR OTHER USE OF THIS DOCUMENT IS TO BE MADE WITHOUT THE PRIOR WRITTEN CONSENT OF Senscient Ltd.

ELDS Transmitter Connections

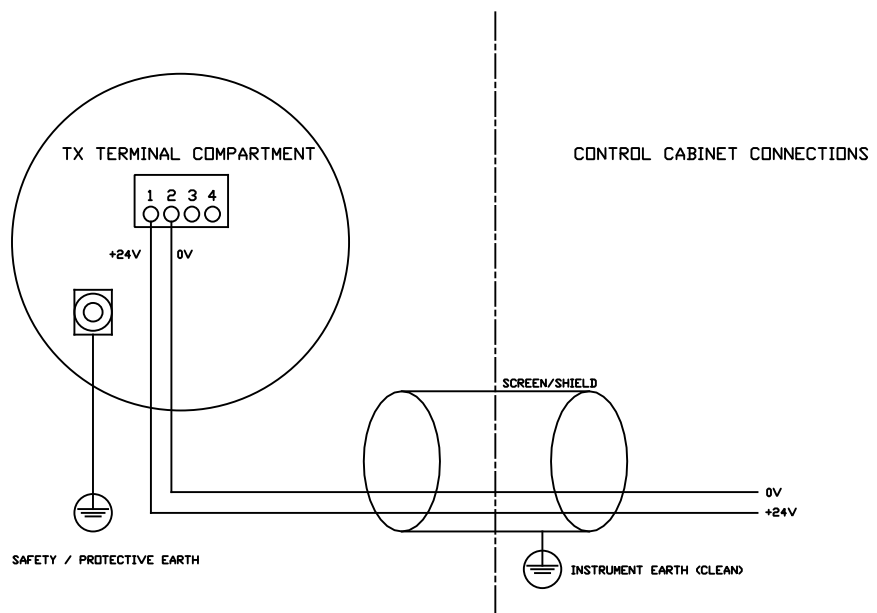

NOTES:

ELDS Receiver Connections (Isolated Output)

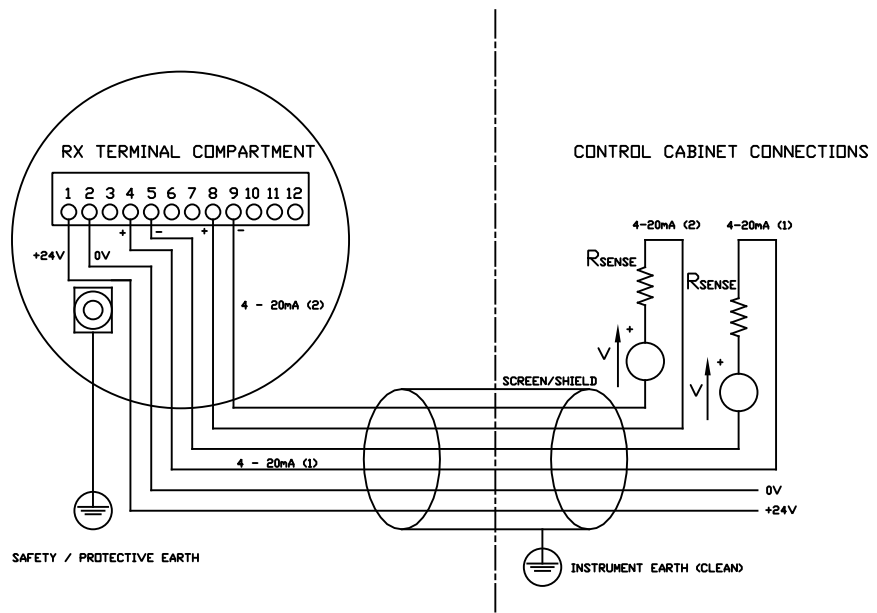

Vendor/Supplier Name:	Senscient		
Vendor/Supplier Doc. No.:	Page 6 of 6	Rev Date:	Rev No.:
Drawing No.:	01-01-2556-D	21/3/17	1
Document title:	WIRING - ISOLATED OUTPUT GENERAL ARRANGMENT DRAWING FOR ELDS 1000/2000		
Equipment Description:	XD / XC ELDS GAS DETECTORS		
Paper Size A3	Scale: NTS		
ALL MEASUREMENTS IN mm UNLESS OTHERWISE STATED			