



**GENERAL MONITORS**

# **Model SM100**

## **Aspirated Sampling Module**



The information and technical data disclosed in this document may be used and disseminated only for the purposes and to the extent specifically authorized in writing by General Monitors.

**Instruction Manual** **01-12**

General Monitors reserves the right to change published specifications and designs without prior notice.

MANSM100ASP

**Part No.**  
**Revision**

**MANSM100ASP**  
**B/01-12**

This page intentionally left blank.

# Table of Contents

<b>TABLE OF FIGURES</b> .....	<b>IV</b>
<b>TABLE OF TABLES</b> .....	<b>IV</b>
<b>1.0 INTRODUCTION</b> .....	<b>5</b>
1.1 Protection for Life .....	5
1.2 Special Cautions and Warnings .....	5
1.3 General Warnings and Cautions .....	5
1.4 General Information .....	6
1.5 Terminology .....	9
<b>2.0 INSTALLATION</b> .....	<b>10</b>
2.1 General .....	10
2.2 Mounting the Aspirated SM100 Unit (All Models) .....	10
2.3 Sample Line Placement between Aspirated SM100 and Gas Monitor .....	11
2.4 Sample Line Placement .....	12
2.5 Exhaust Line Placement .....	16
2.6 Aspirator Connection.....	16
2.7 Electrical Connection .....	16
2.8 Initial Start-up .....	19
<b>3.0 CALIBRATION AND OPERATION</b> .....	<b>20</b>
3.1 Introduction .....	20
3.2 Calibration Procedures.....	20
3.3 Operation .....	20
<b>4.0 MAINTENANCE AND TROUBLESHOOTING GUIDELINES</b> .....	<b>21</b>
4.1 Maintenance.....	21
4.2 Troubleshooting Guidelines .....	22
4.3 Replacement Parts.....	23
<b>5.0 CUSTOMER SUPPORT</b> .....	<b>24</b>
<b>6.0 APPENDIX A</b> .....	<b>25</b>
6.1 Warranty.....	25
6.2 Specifications .....	26

## Table of Figures

Figure 1-1 SM100 Aspirated Sampling Pump (P/N 10058101) .....	6
Figure 1-2 Sampling Module Installation with S4000CH (or S4000TH) Gas Detector.....	7
Figure 1-3 Sampling Module Installation for TS4000H Toxic Gas Detector.....	7
Figure 1-4 Sampling Module Installation for Infrared Gas Detector .....	8
Figure 1-5 Identification Label .....	9
Figure 2-1 Three General Monitors S4000CH Detectors and Sampling Module.....	13
Figure 2-2 Three General Monitors TS4000H Detectors and Sampling Module .....	13
Figure 2-3 Three General Monitors IR Detectors and Sampling Module .....	14
Figure 2-4 Typical Wiring.....	17

## Table of Tables

Table 2-1 Parts List.....	11
Table 2-2 Wiring Identification .....	18
Table 5-1: GM Contacts .....	24

## 1.0 Introduction

### 1.1 Protection for Life

General Monitors' mission is to benefit society by providing solutions through industry-leading safety products, services and systems that save lives and protect capital resources from the dangers of hazardous flames, gases and vapors.

The safety products you have purchased should be handled carefully and installed, calibrated and maintained in accordance with this instruction manual. Remember, these products are for your safety.

### 1.2 Special Cautions and Warnings

This instruction manual includes numerous cautions and warnings that are included to prevent injury to personnel and prevent damage to equipment.



**WARNING:** TOXIC, COMBUSTIBLE, AND FLAMMABLE GASES AND VAPORS ARE VERY DANGEROUS. USE EXTREME CAUTION WHEN THESE HAZARDS ARE PRESENT.

### 1.3 General Warnings and Cautions

Extremely high concentrations of combustible gas or vapor between the lower explosive limit (LEL) and the upper explosive limit (UEL) will cause the indication on the General Monitors Gas Detector to indicate full scale or above full scale. If the concentration level is further increased and exceeds the UEL, the display will continue to show an above scale indication. Gas or vapor concentrations above the UEL are extremely dangerous since the instrument cannot measure them accurately, and when reduced by the addition of air to a level below the UEL, they again constitute a violently explosive mixture.

Therefore, every alarm causing condition or situation must be investigated to determine that the area being monitored does not contain a gas or vapor in air mixture that exceeds the LEL or UEL.

**FAILURE TO FOLLOW THE ABOVE WARNING CAN RESULT IN SERIOUS PERSONAL INJURY OR DEATH.**



**CAUTION:**

1. Perform periodic leak check on all of this unit's flow system components and fittings. Ensure the flow is within specifications.
2. As with all sensors, high levels of, or long exposure to, certain compounds in the tested atmosphere contaminate the sensors. In atmospheres where an SM100 - Aspirated Model may be exposed to such materials, calibration should be performed frequently to ensure that channel operation is dependable and display indications are accurate.
3. The only absolute method to ensure the proper overall operation of this unit is to check the associated sensor (s) with a known concentration of the gas for which

it has been calibrated. Consequently, calibration checks must be included as part of the routine inspection of the system.

**FAILURE TO FOLLOW THE ABOVE CAUTION CAN RESULT IN INJURY, PRODUCT DAMAGE, AND / OR AN UNSAFE CONDITION.**

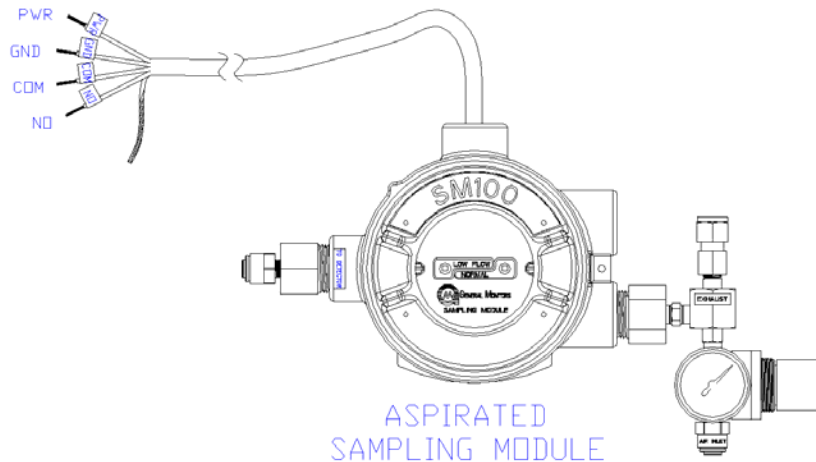

**Figure 1-1 SM100 Aspirated Sampling Pump (P/N 10058101)**

## 1.4 General Information

The SM100 - Aspirated Model:

- must be used with an General Monitors Gas Detector (available separately)
- draws a gas sample from the monitored area, through a sample line (available separately) to the General Monitors Gas Detector sensor
- samples areas that are remote, inaccessible, too hot or too cold for direct sensor monitoring, such as:
  - ducts carrying combustible or toxic gas
  - wet wells
  - printing drying ovens
  - storage tanks

A properly-installed unit for a single SM100 General Monitors Gas Detector is shown in FIGURE 1-2. It is also possible for one Aspirated SM100 to supply sample gas for up to three General Monitors Gas Detectors. This procedure:

- is useful when monitoring up to three different gases.
- requires additional General Monitors Gas Detectors with individual flow accessories.
- is further detailed in Section 2, "Installation."

### 1.4.1 Unpacking Unit

Carefully unpack your SM100 (and General Monitors Gas Detector, if also newly purchased) from shipping carton(s). Compare enclosed items with the packing list to ensure all parts

ordered were received; contact shipper or carrier if discrepancies exist.

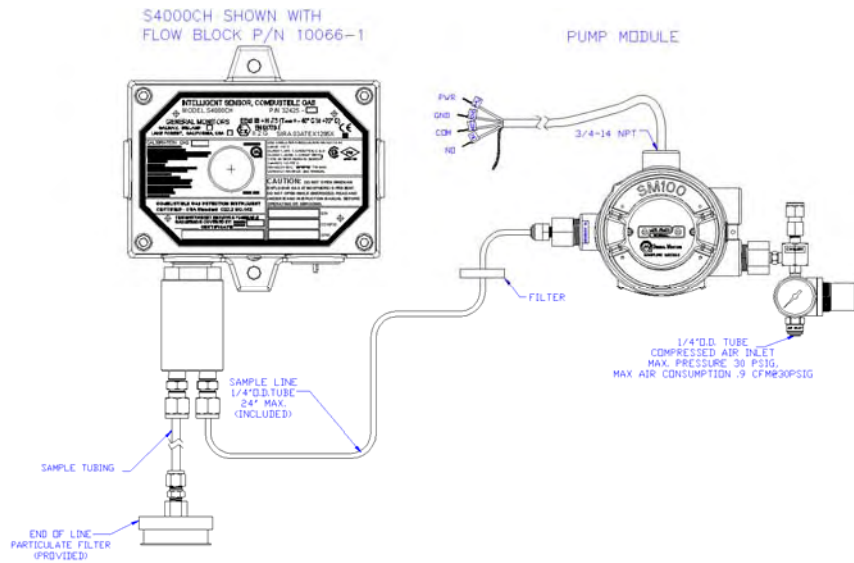

**Figure 1-2 Sampling Module Installation with S4000CH (or S4000TH) Gas Detector**

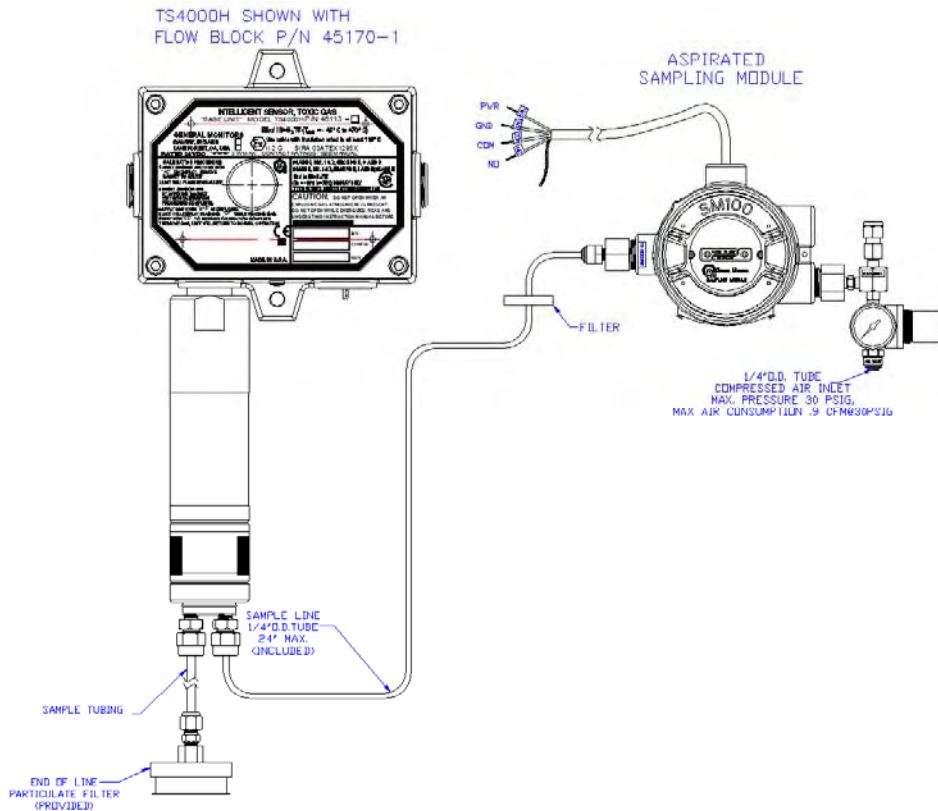

**Figure 1-3 Sampling Module Installation for TS4000H Toxic Gas Detector**

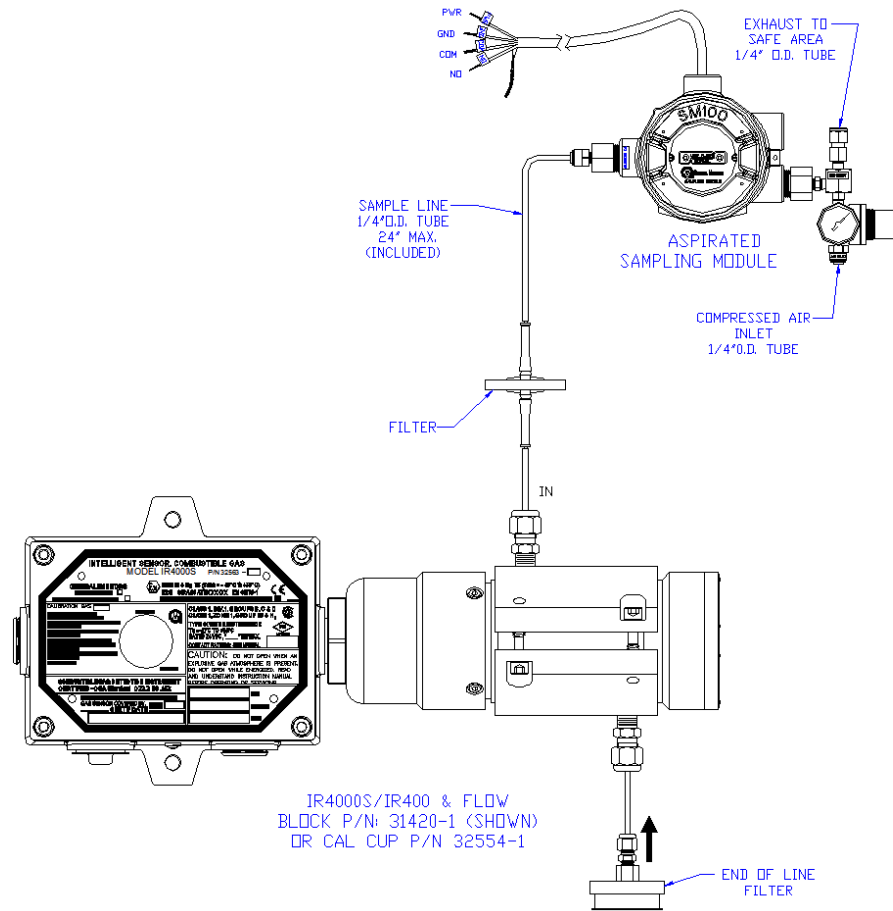

**Figure 1-4 Sampling Module Installation for Infrared Gas Detector**

Each Aspirated SM100 package contains:

- Aspirated SM100
- Tubing and in-line filter
- End-of-line filter
- Instruction manual

### 1.4.2 Unit Identification

The Aspirated SM100's part number (P/N 10058101) can be found in the identification label located on the side of the unit (FIGURE 1-5). See Section 6.2 for unit specifications.



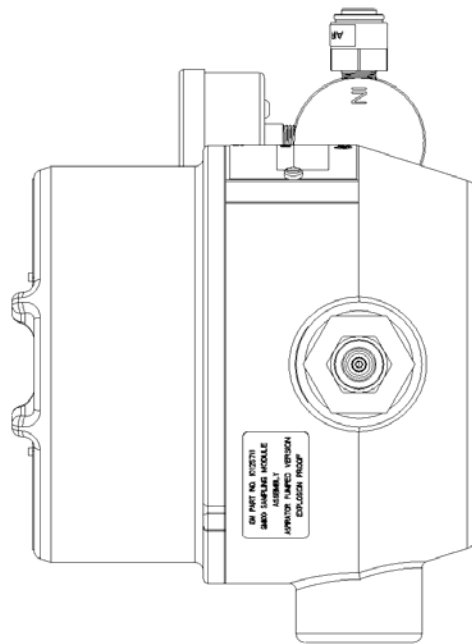

Figure 1-5 Identification Label

## 1.5 Terminology

**ELECTROCHEMICAL SENSOR** - Sensor employing the reactions of chemicals generating electric currents to detect certain gases.

**EXHAUST GAS** - Gas after it has passed through the sensor.

**FLOW RATE** -The volume-per-minute of gas in the sample line.

**SPAN** - Full scale or up-scale reading on the meter display.

**SPAN GAS VALUE** - Gas concentration which gives the instrument an up scale or full scale value. This value is usually printed on the gas cylinder containing the gas.

**SPANNING** - Process of placing a full scale or up scale meter reading on the display by using calibration span gas cylinders.

**ZERO** - A zero (0) indication on the meter display usually indicates ambient air present or no hazardous gases present.

**ZEROING** - Processes for placing a zero indication on meter display.

## 2.0 Installation

### 2.1 General

Install the Aspirated SM100 in the correct area classified in your facility.

The explosion-proof model hazardous area classification is Class I, Division 1, Groups A, B, C and D. It is important that all local and national codes be followed when installing this model in a classified area.

Double check the area classification of the SM100. Refer to FIGURE 1-5 to find the area classification label on your unit. Ensure that the General Monitors Gas Detector is rated properly by referring to General Monitors Gas Detector instruction manual (P/N 10036101) for more details.



**WARNING: Do not mix units with different area classifications. All units used in a classified area must have the proper area classification. Otherwise, an explosion hazard will exist, resulting in a possible explosion, injury or death.**

**The SM100 for a general-purpose (GP) monitor can be a source of ignition. Install, locate and operate only in a non-hazardous area and in accordance with applicable codes.**

**If sampling from or exhausting into a separate location, the installation requires flashback arrestors at the inlet from a hazardous location and at the outlet to a hazardous location, to prevent the propagation of ignition of hazardous gases. Routinely check for aspirated system leaks that could create an explosive environment inside the enclosure.**

**Read and follow all instructions, warnings and cautions pertaining to this gas monitor. FAILURE TO FOLLOW THIS WARNING CAN CAUSE IGNITION OF EXPLOSIVE ENVIRONMENTS RESULTING IN SERIOUS PERSONAL INJURY OR DEATH.**

### 2.2 Mounting the Aspirated SM100 Unit (All Models)

1. Locate the Aspirated SM100 and the General Monitors Gas Detector(s) in a clean, accessible location.
  - Since the unit enclosure is non-corrosive, it can be mounted to the outside of a building or in other wet environments.
  - Use of Teflon tape or non-hardening thread sealant for environmental reasons is acceptable.
  - When installing multiple General Monitors Gas Detectors, locate all monitors within 18 inches (45 cm) of each other.



**CAUTION: Ensure that Aspirated SM100 or the General Monitors Gas Detector unit front covers are not blocked or obscured. A blocked front cover will obscure the gas reading**

indication and SM100 indications. The unit must be mounted with the electrical input facing down and the label clearly readable.

2. Mount the Aspirated SM100 and General Monitors Gas Detector to a wall:
  - From the electrical conduit or
  - By using optional mounting strap (P/N 10047561) and the four holes in the rear of the units.
3. Mount General Monitors Gas Detector with the GAS INLET on the flow accessory facing downward.
4. Mount Aspirated Sample Module EXHAUST tubing so that the end of the tubing is facing downward and is the lowest point of the tubing (see FIGURES 1-2 through 1-4).



**CAUTION:** The General Monitors Gas Detector must be mounted with the sensor inlet fitting on the flow accessory pointed downward; otherwise, the unit may become inoperative.

## 2.3 Sample Line Placement between Aspirated SM100 and Gas Monitor

1. Remove all protective packaging plugs and/or caps from Aspirated SM100 gas INLET and EXHAUST ports.
2. Locate the Aspirated SM100 flow block. Install the flow block(s) on the General Monitors Gas Detector(s). See FIGURES 1-2 through 1-4.
  - Additional flow blocks are available for additional General Monitors Gas Detectors.
  - Refer to TABLE 2-1 for a description and part number for additional flow blocks.



**WARNING:** Install the proper flow block with the correct area classification for your additional General Monitors Gas Detectors. Incorrect flow blocks will not enable the General Monitors Gas Detector to properly monitor gas. Incorrect area classification will present an ignition source, which may cause an explosion resulting in injury or death.

ITEM	PART NO.
S4000CH/TH Flow Chamber	10066
TS4000H Flow Block Assembly	45170-1
IR400 Flow Block	31420-1

**Table 2-1 Parts List**

3. Attach the supplied tubing to the Aspirated SM100 port labeled "TO DETECTOR".
4. Attach the other end of the supplied tubing to the side of the flow block (FIGURES 1-2 through 1-4).

- Tubing can be trimmed to ensure that there are no kinks.



**CAUTION: The in-line filter must be used before the aspirated pump to prevent water entry from damaging unit.**

- In-line filter (P/N 10051406) must be used somewhere along the tubing length. Ensure that the arrow on the in line filter is pointing towards the Aspirated SM100.
- If installing additional General Monitors Gas Detectors, install tubing between units as shown in FIGURES 2-1 through 2-4. Use tubing compatible with the target gas.
- GENERAL MONITORS tubing is available (P/N 600771).

## 2.4 Sample Line Placement

The Aspirated SM100 draws a gas sample to the internally-mounted General Monitors Gas Detector sensor.

- The Aspirated SM100 can be mounted up to 100 feet (30 meters) away from the monitored area.
- It uses 3/8-inch OD tubing to connect the Aspirated SM100 sample inlet to the end of the sample line in the monitored area. Tubing must be compatible with the sampled gas.
- It takes a maximum of 30 seconds for the sample gas to reach the Aspirated SM100 when 50 feet (15.25 meters) of tubing is used:
  - To decrease this time, shorten the sample line length.
  - It is generally good practice to make the sample line as short as possible.
- Depending on the gas characteristics, the end of the sampling tubing and the sample inlet should be mounted to best optimize sampling of that particular gas. Consult your architect, facility manager, or safety engineer for guidance in proper placement of the sampling tube inlet.
- The particulate filter provided should be used at the sample end of the sample line to help prevent dirt and dust from clogging the sample line. This filter must be compatible with the gas being sampled.

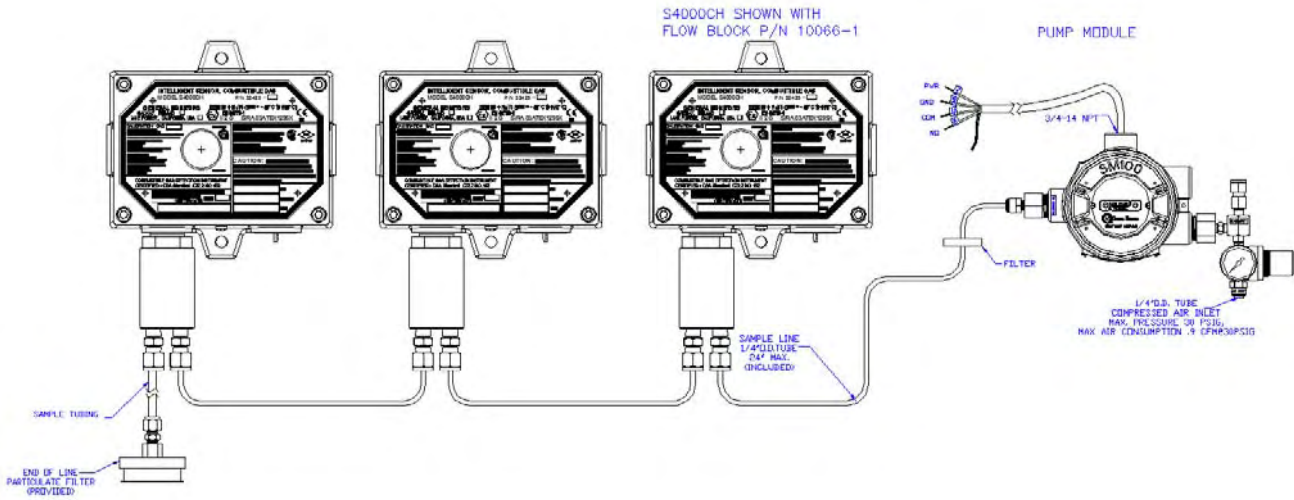

**Figure 2-1 Three General Monitors S4000CH Detectors and Sampling Module**

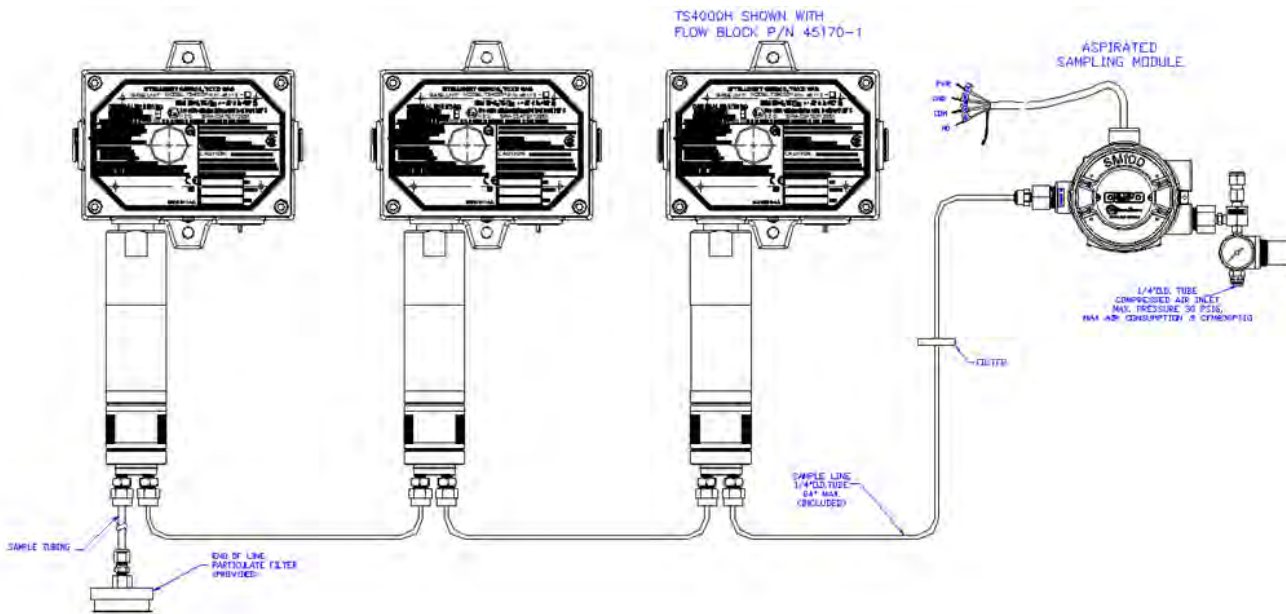

**Figure 2-2 Three General Monitors TS4000H Detectors and Sampling Module**

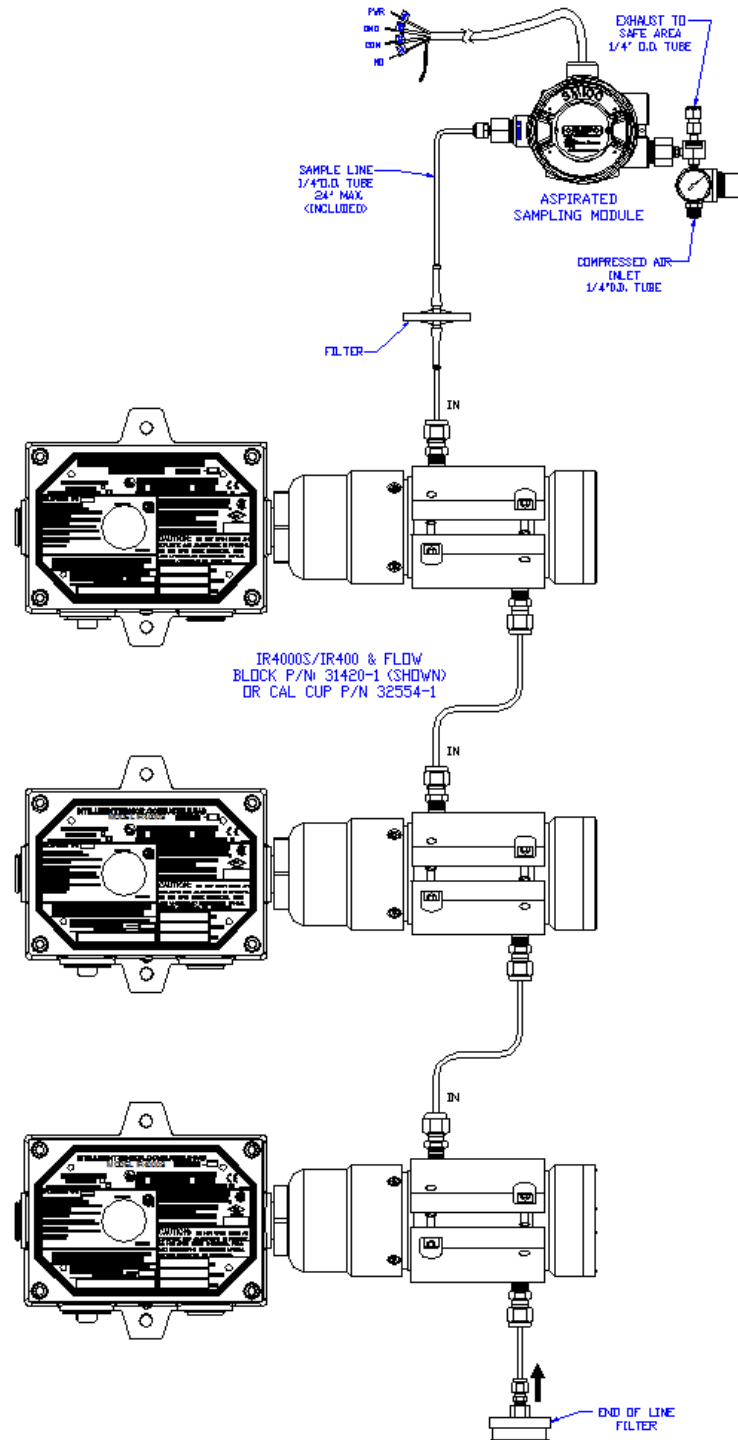

**Figure 2-3 Three General Monitors IR Detectors and Sampling Module**

**It is recommended that a stainless steel or Teflon sample line be used for monitoring gases that are highly reactive such as:**

- Ammonia
  - Chlorine
  - Chlorine dioxide
  - Hydrogen chloride
  - Hydrogen sulfide
  - Nitrogen dioxide
  - Sulfur dioxide
- Use an end-of-line filter (P/N 637921) with the above gases. The filter and sample line should be inspected periodically and replaced if dirty.



**CAUTION: All General Monitors Gas Detectors must be mounted in ambient, interference-free air; otherwise, erroneous readings may result. Do not attempt to clean the sample line by applying compressed air.**

1. Remove all protective packaging plugs and/or caps from the Aspirated SM100:
  - Gas inlet
  - Exhaust ports
2. Attach a 1/4-inch (6.35 mm) OD sample tubing to the flow block sample inlet fitting on the General Monitors Gas Detector (FIGURE 1-2). Ensure tubing is compatible with the sampled gas.
3. Route the sample tubing to the area to be monitored.

---

**NOTE:** Do not run the sample tubing in water or across areas of vibration, doorways, man ways or access ways; otherwise, a sample tubing leak or tripping hazard may result.

---

4. Using suitable hardware (not supplied):
  - Fasten the sample tubing to supports
  - Fasten the end of the sample tubing and sample inlet in the monitoring area.
    - The sample inlet should be pointed downward to prevent dirt and water from entering the sample tubing line.
5. Install the provided end-of-line filter at the end of the sampling tubing, if applicable.
6. Check for leaks along the entire length of the sample tubing line. Any leak will dilute the gas sample from the area of interest and give a lower than actual gas reading.

## 2.5 Exhaust Line Placement

1. Attach a 1/4-inch (6.35 mm) OD sample tubing to the exhaust outlet fitting on the Aspirated SM100 Unit.
2. Route the exhaust tubing into a safe area where the gas sample can be vented. Avoid any sharp bends or elbows. Route the tubing to allow any collected water to drain.
  - The maximum exhaust tubing length is 20 feet (6 meters).

---

**NOTE:** Do not run the exhaust tubing in water or across areas of vibration or across doorways, man ways or access ways; otherwise, a leak in the exhaust tubing or a tripping hazard may result.

---

3. Fasten the exhaust tubing to supports using suitable hardware (not supplied).
4. Fasten the end of the exhaust tubing in the area of interest by using suitable hardware (not supplied).
  - Exhaust inlet should be pointed downward to prevent dirt and water from entering the exhaust tubing line.

---

**NOTE:** Exhaust to a safe or non-hazardous area only.

---

5. Check for leaks along entire length of the exhaust tubing line.

## 2.6 Aspirator Connection

Connect the Aspirated SM100 to compressed air via the 1/4" OD tube fitting at the top of the unit. The compressed air must be instrument-grade quality. Maximum inlet air pressure must not exceed 25 psig (172 kPa).



**WARNING:** Connecting the Aspirated SM100 to an inferior-quality or an over-pressure air supply can cause incorrect gas readings or damage to the SM100.

## 2.7 Electrical Connection

A flow detector within the Aspirated SM100 activates a relay when sufficient flow exists for proper gas detection. Generally, the General Monitors Gas Detector output signal is routed through this relay. When the flow is insufficient, the relay opens and the gas signal is interrupted. Equipment monitoring this signal can be configured to sound an alarm when signal is interrupted. See FIGURE 2-4 for a typical wiring schematic of the SM100 and General Monitors Gas Detector.



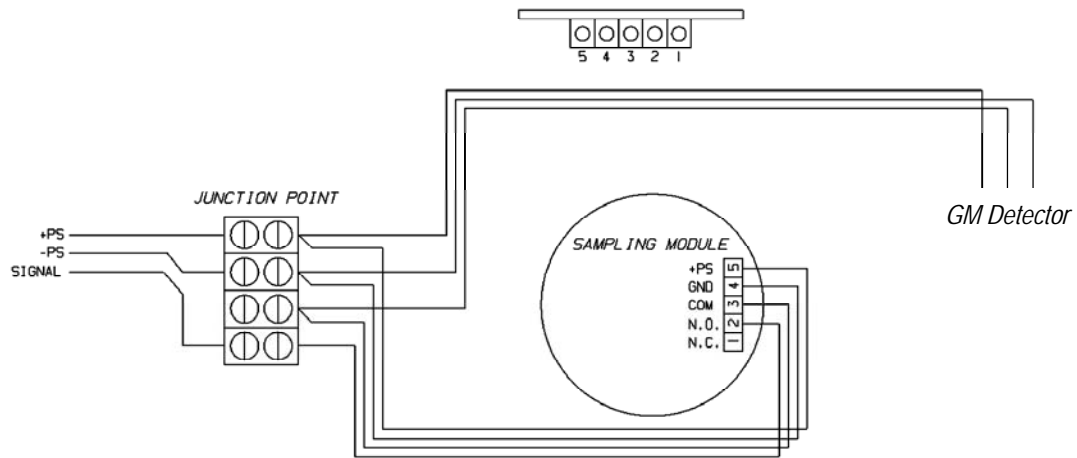

**Figure 2-4 Typical Wiring**

Other devices that alert when the flow loss relay activates can be connected to relay contact with the Aspirated SM100.

**NOTE:** The Aspirated SM100 requires a four-conductor wire. Use shielded wire if installing the system where portable two-way radio, welding or large machinery are located. The shield of any wire must not be grounded at the SM100 or the General Monitors Gas Detector. The shield must be grounded at one point only, usually at the controlling instrument.

### 2.7.1 Electrical Connection Procedure

1. Turn power OFF from the receiving instrument or power supply for the system.



**CAUTION:** Failure to remove power from instrument may damage the Aspirated SM100 and/or the General Monitors Gas Detector during wiring.

2. If connecting the field wires to the wiring harness, observe the identity of the conductors within the wiring harness. Connect field wires to the appropriate harness conductors.
  - Remove and discard the cable grip threaded into the enclosure.
  - Follow National Electrical and local procedural Codes.
3. If not using the attached wiring harness:
  - A. Remove the top cover of the SM100 by rotating the cover counterclockwise.



**WARNING:** Ensure that no flammable or combustible gas exists in the atmosphere by checking with a portable instrument capable of detecting combustible gases; otherwise, a spark may generate and cause an explosion, which may result in injury or death. Do not allow the lid to remain off of the explosion-proof Aspirated SM100. Flammable or combustible gas in the atmosphere may ignite a spark; that, in turn, may cause an explosion and result in injury or death.

- B. Unscrew and remove the two top-cover screws.
- C. Lift top cover to expose the wiring terminal strip on the bottom side of the cover.
- D. Loosen terminal strip screws and remove wiring harness.
  - a. Remove and discard the wiring harness and cable grip threaded into the enclosure
  - b. Install a conduit seal into the enclosure.
- E. Route a cable (not supplied) through the electrical entry of the Aspirated SM100.
- F. Connect the conductors to the wiring terminal strip noting the identity of the wires. See FIGURE 2-4 and TABLE 2-2.
- G. Replace the top cover and tighten with the two screws.
- H. Replace lid and tighten in place.



**WARNING:** Do not allow lid to remain off of the explosion-proof Aspirated SM100. Flammable or combustible gas in the atmosphere may ignite a spark; that, in turn, may cause an explosion and result in injury or death.

POSITION	DESCRIPTION
1	Normally closed contact of the flow loss relay
2	Normally open contact of the flow loss relay
3	Common position of the flow loss relay
4	Ground or negative of the power supply
5	Positive or supply position of the power supply

**Table 2-2 Wiring Identification**

4. Wire the other end of the wiring cable to your read-out instrument and power supply, ensuring the cable from the Aspirated SM100 is wired to the proper connections on the instrument. Consult the instrument instruction manual for more wiring details.

## 2.8 Initial Start-up

Before starting up the Aspirated SM100:

1. Check wiring connections; see FIGURE 2-4 and TABLE 2-2.
2. Ensure that power supplied to the controlling instrument is the proper voltage with sufficient current capacity to operate the instrument. Refer to the instrument instruction manual for proper power set-up.
3. Apply power to the instrument through a remote circuit breaker.



**CAUTION: If relays in the controlling instrument are wired to external devices (e.g. horns, exhaust fans, and fire suppression systems), these devices may activate while adjustments are performed during the following procedures. Consult equipment instruction manual for further details. All instruments must be returned to normal operation when Aspirated SM100 and General Monitors Gas Detector adjustments are completed.**

4. Before applying compressed air to the Aspirated SM100 compressed air inlet:
  - a. Adjust the internal pressure regulator for 0 psig by pulling out the red locking ring on the regulator and adjusting the knob fully counterclockwise; see FIGURE 1-2.
  - b. Ensure the exhaust is not restricted.
5. Apply the compressed air to the compressed air inlet of the Aspirated SM100 at 20 to 25 psig (137 to 172 kPa).
6. Pull out the red locking ring and adjust the knob on the air regulator to obtain a reading of 10 psig (70 kPa).
7. Notice the low flow indication on the front panel:
  - If low flow indication is **not** ON, push in the air regulator red locking ring to lock the regulator at this pressure.
  - If the low flow indication is **still** ON, increase air pressure by turning the knob until the indication turns OFF [do not exceed 15 psig (100 kPa)]. When indication turns OFF, push in the red locking ring of the air regulator.
  - If the low flow indication is **still** ON at 15 psig (100 kPa), reduce the pressure below 10 psig (70 kPa) until the low flow indication turns OFF.

## 3.0 Calibration and Operation

### 3.1 Introduction

The calibration of each sensor connected to the SM100 sampling pump should be performed according to the instrument's instruction manual. Please follow the calibration cycle specified therein.

### 3.2 Calibration Procedures

Place the instrument receiving the signal from the General Monitors Gas Detector into CALIBRATION mode, if applicable.



**WARNING:** It is necessary to put the receiving instrument in CALIBRATION mode. If the instrument is not in CALIBRATION mode, any alarm relays may energize and activate any safety devices which are connected to the alarm relays of the instrument.

#### Equipment Needed:

- Calibration Equipment: See field devices' manual.
- Appropriate ZERO and SPAN Gas Cylinders (refer to the General Monitors Gas Detector Instruction Manual).

---

**NOTE:** If unsure of which SPAN gas to use or of the SPAN gas value, consult your safety engineer or officer or facility manager.

---

- Calibrate per the instruction manual for the detector.

### 3.3 Operation

There are only two indicators on the front cover of the Aspirated SM100 which affect the operation of the unit.

- The NORMAL (green LED) indicator, shows that there is sufficient sample flow (greater than 0.5 LPM).
- The LOW FLOW (red LED) indicator, when ON, indicates flow rate is less than 0.5 LPM, insufficient gas flow for proper monitoring. Refer to Section 4, "Troubleshooting Guidelines" for corrective action.



**WARNING:** The pressure switch can fail and the orifice can clog if water enters the system. Always use the proper in-line filter (P/N 10051406).

## 4.0 Maintenance and Troubleshooting Guidelines

### 4.1 Maintenance

The Aspirated SM100 requires minimal maintenance. However, the filters need routine inspection and possible replacement. It is good practice to have replacement filters on hand to minimize any down time of your unit (see Section 4.3).

#### Filter Maintenance

Filter maintenance consists of visual inspection of the two filters, end-of-line filter and the in-line filter which blocks water from entering the pump module. When new, filters are white; when loaded with dust or dirt, they normally turn dark in color. Visually inspect the two filters periodically. The frequency of this inspection depends on the environment; if the environment is extremely dirty or dusty, this inspection should be done often.

End-of-line filters must be located so that they are not exposed to liquids or steam. If liquids become entrapped within a filter, replace the filter as it will interfere with proper operation of the unit.

## 4.2 Troubleshooting Guidelines

<b>SYMPTOM</b>	<b>POSSIBLE CAUSE</b>	<b>PROBABLE SOLUTION</b>
Low Flow indicator is ON	Sample line clogged	Check and replace or clean sample line
	A leak internal to the SM100	Check tubing inside the SM100, especially the fittings
	Inoperative flow switch	Replace flow switch (preset at factory)
	No or low air pressure to the aspirator	Supply compressed air to the air inlet of the SM100
	Air pressure regulator set too low	Re-adjust air pressure regulator
	The sample line is under a vacuum	Remove vacuum from sample line inlet
	Dirty/clogged aspirator	Clean or replace aspirator
	Dirty end-of-line or in-line filter	Replace dirty end-of-line or in-line filter
No sensor output or low output	Exhaust clogged	Clean or replace exhaust tubing
	Sensor is approaching its end-of-life	Replace sensor
	The ambient is too cold or too hot for the sensor	Place the SM100 in warmer or cooler ambient environment
	A leak in the sample line	Check and repair any leaks in the sample line
	Inoperative detector electronics	Replace printed circuit board
	Exhaust clogged or restricted	Unclog or remove the restriction on the exhaust
	Dirty sample filter	Replace dirty sample filter
	Inoperative flow sensor	Replace inoperative flow sensor
	Sensor wiring plug loose	Reconnect sensor wiring plug
	Bad wiring connection between instrument and SM100	Check wiring and replace or repair any inoperative wiring or connections
	No power to the unit	Turn control instrument ON
	Improper voltage selection at the control instrument	Select proper voltage at the control instrument
	Inoperative relay	Replace printed circuit board assembly

### 4.3 Replacement Parts

DESCRIPTION	PART NO.
PC Board Assembly (requires new label)	10052349
Label, SM100	10051804
Filter, In-line	10051406
Filter, End-of-Line, Includes Cartridge (High Humidity)	637920
Filter, End-of Line, (Reactive Gases)	637921
Filter Cartridge for End-of-Line Filter (General Purpose)	95302
Flashback Arrestor for Explosion-proof Models Only	813159
Gauge, Pressure	638395
Regulator	636411
Pump, Vacuum	631716
Valve, Push-button	635729
Gasket, Flow Block, Explosion-proof	10051112
Sample Line Tubing	600771
Pressure Switch	10050076
Mounting Strap	10047561
O-Ring, S4000CH/TH Flow Block	925-001

-

---

**NOTE:** It is the users responsibility to follow all applicable regulations and to insure continued compliance with the certification, as marked on the label.

---

## 5.0 Customer Support

Area	Phone/Fax/Email
<b>UNITED STATES</b>	
	Toll Free: +1-800-446-4872
	Phone: +1-949-581-4464
Corporate Office: Lake Forest, CA	Fax: +1-949-581-1151 Email: info@generalmonitors.com
	Phone: +1-281-855-6000
	Fax: +1-281-855-3290
Houston, TX	Email: gmhou@generalmonitors.com
<b>UNITED KINGDOM</b>	
	Phone: +44-1625-619-583
	Fax: +44-1625-619-098
	Email: info@generalmonitors.co.uk
<b>IRELAND</b>	
	Phone: +353-91-751175
	Fax: +353-91-751317
	Email: info@gmil.ie
<b>SINGAPORE</b>	
	Phone: +65-6-748-3488
	Fax: +65-6-748-1911
	Email: genmon@gmpacifica.com.sg
<b>MIDDLE EAST</b>	
	Phone: +971-4-8143814
	Fax: +971-4-8857587
	Email: gmme@emirates.net.ae

**Table 5-1: GM Contacts**



## 6.0 Appendix A

### 6.1 Warranty

**Warranty**-Seller warrants that this product will be free from mechanical defect or faulty workmanship for a period of eighteen (18) months from date of shipment or one (1) year from installation, whichever occurs first, provided it is maintained and used in accordance with Seller's instructions and/or recommendations. This warranty does not apply to expendable or consumable parts whose normal life expectancy is less than one (1) year such as, but not limited to, non-rechargeable batteries, filament units, filter, lamps, fuses etc. The Seller shall be released from all obligations under this warranty in the event repairs or modifications are made by persons other than its own or authorized service personnel or if the warranty claim results from physical abuse or misuse of the product. No agent, employee or representative of the Seller has any authority to bind the Seller to any affirmation, representation or warranty concerning the product. Seller makes no warranty concerning components or accessories not manufactured by the Seller, but will pass on to the Purchaser all warranties of manufacturers of such components. **THIS WARRANTY IS IN LIEU OF ALL OTHER WARRANTIES, EXPRESSED, IMPLIED OR STATUTORY, AND IS STRICTLY LIMITED TO THE TERMS HEREOF. SELLER**

**SPECIFICALLY DISCLAIMS ANY WARRANTY OF MERCHANTABILITY OR OF FITNESS FOR A PARTICULAR PURPOSE.**

**Exclusive Remedy**-It is expressly agreed that Purchaser's sole and exclusive remedy for breach of the above warranty, for any tortious conduct of Seller, or for any other cause of action, shall be the repair and/or replacement at Seller's option, of any equipment or parts thereof, which after examination by Seller is proven to be defective. Replacement equipment and/or parts will be provided at no cost to Purchaser, F.O.B. Seller's Plant. Failure of Seller to successfully repair any nonconforming product shall not cause the remedy established hereby to fail of its essential purpose.

**Exclusion of Consequential Damage**-Purchaser specifically understands and agrees that under no circumstances will seller be liable to purchaser for economic, special, incidental or consequential damages or losses of any kind whatsoever, including but not limited to, loss of anticipated profits and any other loss caused by reason of nonoperation of the goods. This exclusion is applicable to claims for breach of warranty, tortious conduct or any other cause of action against seller.

## 6.2 Specifications

<b>ASPIRATOR AIR REQUIREMENTS</b>	Instrument grade air
<b>MAXIMUM ASPIRATOR PRESSURE</b>	30 psig (206 kPa)
<b>MINIMUM ASPIRATOR AIR CONSUMPTION</b>	0.6 CFM at 20 psig (137 kPa)
<b>MAXIMUM ASPIRATOR AIR CONSUMPTION</b>	0.9 CFM at 30 psig (206 kPa)
<b>MAXIMUM POWER CONSUMPTION</b>	1.8 W at 9 to 30 VDC
<b>CABLE REQUIREMENTS FOR ALL GASES</b>	Four conductor, shielded, 18 AWG (typical)
<b>SAMPLE TRANSPORT TIME</b>	30 seconds at 0.5 LPM with 50 feet (15.25 meters) of 0.180 (4.57 mm) ID sample tubing
<b>NOMINAL SAMPLE FLOW RATE</b>	2 CFH (1 LPM)
<b>MINIMUM SAMPLE FLOW RATE</b>	1 CFH (0.5 LPM)
<b>MAXIMUM SAMPLE TUBING LENGTH</b>	100 feet (30 meters)
<b>MAXIMUM EXHAUST TUBING LENGTH</b>	20 feet (6 meters)
<b>INLET FITTINGS</b>	1/4" (6.35 mm) OD tube fitting
<b>EXHAUST FITTING</b>	1/4" (6.35 mm) OD tube fitting
<b>CALIBRATION FITTING</b>	1/4" (6.35 mm) OD barbed fitting
<b>OVERALL DIMENSIONS</b>	9" x 6" x 5" (228.6 mm x 152.4 mm x 127 mm)
<b>WEIGHT</b>	4.5 lbs. (2 kg)
<b>RATING</b>	Explosion-proof enclosure, Class I, Groups A, B, C and D, Division 1, Hazardous Locations
<b>ELECTRICAL ENTRY</b>	3/4-14 NPT
<b>TROUBLE RELAY RATING</b>	0.6 A at 125 VAC 0.6 A at 110 VDC 2.0 A at 30 VDC
<b>TEMPERATURE RANGE</b>	-20°C to 55°C (-4°F to 131°F)
<b>HUMIDITY</b>	15 to 95% RH, non-condensing
<b>APPROVAL</b>	C-UL-US (enclosure only)



**ADDENDUM**  
**Product Disposal Considerations**

This product may contain hazardous and/or toxic substances.

EU Member states shall dispose according to WEEE regulations. For further General Monitors' product WEEE disposal information please visit: [www.generalmonitors.com/customer\\_support/faq\\_general.html](http://www.generalmonitors.com/customer_support/faq_general.html)

All other countries or states: please dispose of in accordance with existing federal, state and local environmental control regulations.