



General Monitors

by MSA

Model S4000CH

Intelligent Sensor for
Combustible Gas Detection



The information and technical data disclosed in this document may be used and disseminated only for the purposes and to the extent specifically authorized in writing by General Monitors.

Instruction Manual

08-17

General Monitors reserves the right to change published specifications and designs without prior notice.



**Part No.
Revision**

**MANS4000CH
Q/08-17**

This page intentionally left blank

Table of Contents

TABLE OF FIGURES.....	VI
TABLE OF TABLES.....	VII
QUICK START GUIDE.....	1
Mounting and Wiring	1
Tools Required	1
Terminal Connections	3
1.0 INTRODUCTION	5
1.1 Protection for Life	5
1.2 Special Warnings	5
1.3 System Integrity Verification	6
2.0 PRODUCT DESCRIPTION.....	8
2.1 General Description	8
3.0 INSTALLATION.....	10
3.1 Receipt of Equipment.....	10
3.2 Tools Required.....	10
3.3 Choosing Product Locations.....	10
3.3.1 Remote Mounting of the Sensor from the Electronics	11
3.4 Mounting and Wiring	12
3.5 Terminal Connections	13
3.5.1 Terminal Block TB1 – Sensor Connections	15
3.5.2 Terminal Block TB2 – Power and Signal Connections	15
3.5.3 DC Power and COM Connections	17
3.5.4 Analog Signal Connections.....	17
3.5.5 ARGC Terminal Connections.....	18
3.5.6 Terminal Block TB3 – Relay Connections	18
3.5.7 European Union (EU) Approved Applications.....	19
3.5.8 Cable Termination in the Non-Hazardous Area.....	19
3.6 Maintaining the X/P Integrity	20
3.7 Start-Up Checklist	21
3.8 Start-Up	21
3.9 Relay Reset.....	21
3.10 User Selectable Options	22
3.11 Available Separate Purchase Options	22
3.11.1 Model S4000CH User Menu Structure	23
3.11.2 Calibration Level	24
3.11.3 Warning Relay Settings	24
3.11.4 Alarm Relay Settings.....	24
3.11.5 Modbus Channel 1 Settings.....	25
3.11.6 Modbus Channel 2 Settings.....	25
3.12 HART/Modbus SELECT.....	26
3.13 Gas Check Mode	26
3.13.1 Calibration Check.....	26
3.14 Calibration	27

3.14.1	Calibration Procedure	27
3.14.2	Aborting Calibration.....	28
3.14.3	Adjustable Calibration Level	29
3.14.4	Remaining Sensor Life.....	29
3.14.5	Initializing the Remaining Sensor Life.....	29
3.15	Calibration Equipment.....	30
3.15.1	Portable Purge Calibrator	30
3.16	Remote Gas Calibrator	30
3.17	ARGC Gas Control.....	30
3.18	Automatic Remote Gas Calibrator (ARGC)	31
3.19	Calibration Using the ARGC	31
4.0	MAINTENANCE	34
4.1	General Maintenance.....	34
4.2	Storage.....	34
5.0	TROUBLESHOOTING	35
5.1	Fault Codes & Their Remedies.....	35
5.1.1	F2 Failed to Complete Calibration	35
5.1.2	F3 Flash Checksum Error	35
5.1.3	F4 Sensor Error.....	35
5.1.4	F5 Unused.....	36
5.1.5	F6 Low Supply Voltage	36
5.1.6	F7 EEPROM Error	36
5.1.7	F8 Failure to Complete Setup	36
5.1.8	F9 Gas Check Period Exceeded.....	36
5.1.9	F10 Switch Error	36
5.1.10	F11 Internal Error.....	37
5.1.11	F12 ARGC fault.....	37
5.2	General Monitors' Offices.....	37
6.0	MODBUS INTERFACE	38
6.1	Baud Rate	38
6.2	Data Format	38
6.3	Modbus Read Status Protocol (Query/Response).....	38
6.3.1	Modbus Read Query Message	38
6.3.2	Modbus Read Response Message.....	38
6.4	Modbus Write Command Protocol (Query/Response)	39
6.4.1	Modbus Write Query Message	39
6.4.2	Modbus Write Response Message.....	39
6.5	Function Codes Supported	39
6.6	Exception Responses and Exception Codes.....	39
6.6.1	Exception Response	39
6.6.2	Exception Code.....	40
6.7	S4000CH Command Register Locations	41
6.8	S4000CH Command Register Details	43
6.8.1	Analog (00h).....	43
6.8.2	Mode (01h).....	43
6.8.3	Status/Error (03h).....	44
6.8.4	Unit Type (04h)	44
6.8.5	Software Revision (05h).....	44
6.8.6	Status Block (06h).....	44

6.8.7	Analog Value (06h)	44
6.8.8	Mode & Error (07h)	45
6.8.9	Error & Sensor Life (08h)	45
6.8.10	Display (0x09h & 0x0Ah)	45
6.8.11	Serial Number (0Bh/0Ch)	46
6.8.12	Alarm Settings (0Dh)	46
6.8.13	Warn Settings (0Eh)	46
6.8.14	Com1 Address (0Fh)	47
6.8.15	Com1 Baud Rate (10h)	47
6.8.16	Com1 Data Format (11h)	47
6.8.17	Com2 Address (12h)	48
6.8.18	Com2 Baud Rate (13h)	48
6.8.19	Com2 Data Format (14h)	49
6.8.20	Calibration Level (15h)	49
6.8.21	Reset Alarms (16h)	49
6.8.22	Sensor Life (17h)	49
6.8.23	HazardWatch (Co – Calibration Output) (19h)	50
6.8.24	ARGC (1Ah)	50
6.8.25	PLC Remote Gas Calibration	50
6.8.26	HART Enable (1Dh)	50
6.8.27	HART Test (1Eh)	50
6.8.28	Abort Calibration (1Fh)	51
6.8.29	Total Receive Errors (20h)	51
6.8.30	Bus Activity Rate % (21h)	51
6.8.31	Function Code Errors (22h)	51
6.8.32	Starting Address Errors (23h)	51
6.8.33	Number of Register Errors (24h)	51
6.8.34	RXD CRC Errors Hi (25h)	51
6.8.35	RXD CRC Errors Lo (Same as Hi) (26h)	51
6.8.36	Parity Errors (27h)	51
6.8.37	Overrun errors (28h)	52
6.8.38	Framing Errors (29h)	52
6.8.39	Total Software CH1 Errors (2Ah)	52
6.8.40	New Sensor Calibration (2Bh)	52
6.8.41	Clear Hardware Errors (2Ch)	52
6.8.42	Clear Communication Errors (2Dh)	52
6.8.43	User Information (60h to 6Fh)	56
6.8.44	Total Receive Errors (70h)	56
6.8.45	Bus Activity Rate % (71h)	56
6.8.46	Function Code Errors (72h)	56
6.8.47	Starting Address Errors (73h)	56
6.8.48	Number of Register Errors (74h)	56
6.8.49	RXD CRC Errors Hi (75h)	57
6.8.50	RXD CRC Errors Lo (Same as Hi) (76h)	57
6.8.51	Parity Errors (77h)	57
6.8.52	Overrun Errors (78h)	57
6.8.53	Framing Errors (79h)	57
6.8.54	Total software CH1 errors (7Ah)	57

7.0 APPENDIX	58	
7.1	Warranty	58
7.2	Principle of Operation	58
7.3	Specifications	59

7.3.1	System Specifications	59
7.3.2	Mechanical Specifications	59
7.3.3	Electrical Specifications	59
7.3.4	Cable Requirements	60
7.3.5	Remote Sensor Cable Lengths	61
7.3.6	Environmental Specifications	61
7.4	Approvals	62
7.5	Sensitivities to Other Gases	62
7.6	Spare Parts and Accessories	64
7.6.1	Sensors	64
7.6.2	Sensor Housing	64
7.6.3	Sensor Accessories	64
7.6.4	Calibration Equipment	64
7.6.5	S4000CH Replacement Parts	65
7.6.6	Recommended Spare Parts for One (1) Year	65
7.7	FM Approval	66

Table of Figures

Figure 1: Outline and Mounting Dimensions in inches	1
Figure 2: Outline and Mounting Dimensions (ARGC) in inches	1
Figure 3: Sensor Remote Installation in inches	2
Figure 4: ARGC Remote Installation	2
Figure 5: Spring Type Terminal Block Operation	3
Figure 6: Screw Type Terminal Block Operation.....	3
Figure 7: Model S4000CH Intelligent Sensor	8
Figure 8: Model S4000CH Intelligent Sensor with ARGC	9
Figure 9: ARGC Remote Junction Box Assembly (P/N 80155-1)	9
Figure 10: Outline and Mounting Dimensions in inches	12
Figure 11: Outline and Mounting Dimensions (ARGC) in inches	13
Figure 12: S4000CH Terminal Block Locations	14
Figure 13: Remote Junction Box Terminal Block	14
Figure 14: Spring Type Terminal Block Operation	15
Figure 15: Screw Type Terminal Block Operation.....	16
Figure 16: Wire Strip Length.....	16
Figure 17: Relay Protection for DC and AC Loads.....	19
Figure 18: Relay Reset.....	22
Figure 19: User Menu Structure	23
Figure 20: Calibration Check	26
Figure 21: Automatic Calibration Mode	28
Figure 22: Calibration in Progress Mode.....	28
Figure 23: Calibration Complete Mode.....	28
Figure 24: Remote Gas Calibrator (RGC, P/N 80153-1).....	30
Figure 25: ARGC Gas Control (P/N 80154-1)	31
Figure 26: Calibration Complete Mode.....	32

Table of Tables

Table 1: TB2 Power and Signal Connections.....	15
Table 2: Ground or Common Connections.....	17
Table 3: Power Connections	17
Table 4: Analog Signal Connections	18
Table 5: Alarm Relay Connections	18
Table 6: Warn Relay Connections.....	18
Table 7: Fault Relay Connections	19
Table 8: GM Locations.....	37
Table 9: Data Format.....	38
Table 10: Exception Codes	40
Table 11: Com1 Baud Rate	47
Table 12: Com1 Data Format	47
Table 13: Current Chart.....	48
Table 14: Com2 Baud Rate	49
Table 15: Com2 Data Format	49
Table 16: 24 VDC Cable Lengths with Relays	60
Table 17: 24 VDC Cable Lengths w/o Relays	60
Table 18: ARGC Cable Lengths	60
Table 19: Analog Output Cable Lengths	61
Table 20: Sensor Cable Lengths	61
Table 21: Chemical List	63

Quick Start Guide

Mounting and Wiring

Tools Required

- “5mm” Allen head wrench to remove enclosure lid (included with gas detector).
- Flat-head screwdriver maximum 3/16” (5 mm) width for terminal block connections (included with gas detector).
- Adjustable wrench for conduit or cable gland connections (not included).

Information on Class I Division 1 and Zone 1 wiring methods can be found in the NEC and CEC.

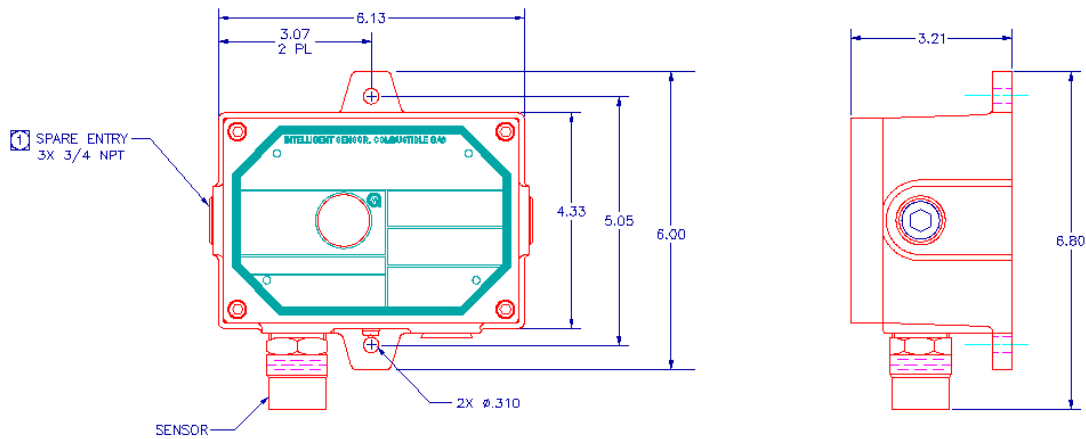

Figure 1: Outline and Mounting Dimensions in inches

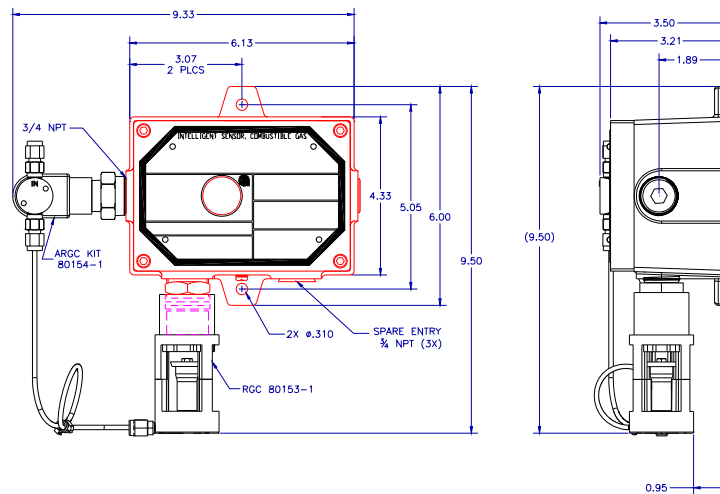

Figure 2: Outline and Mounting Dimensions (ARGC) in inches

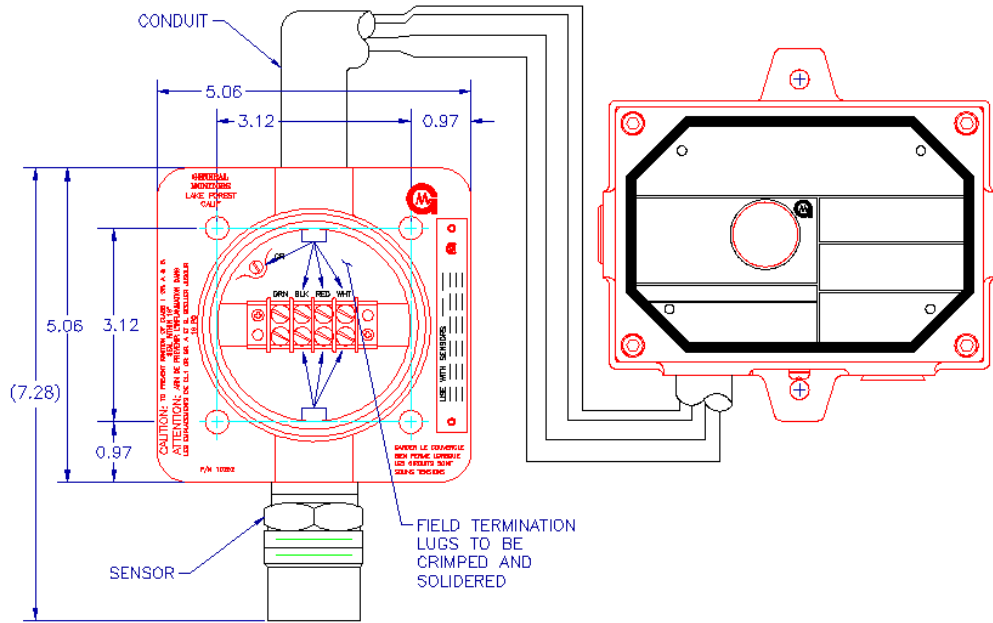

Figure 3: Sensor Remote Installation in inches

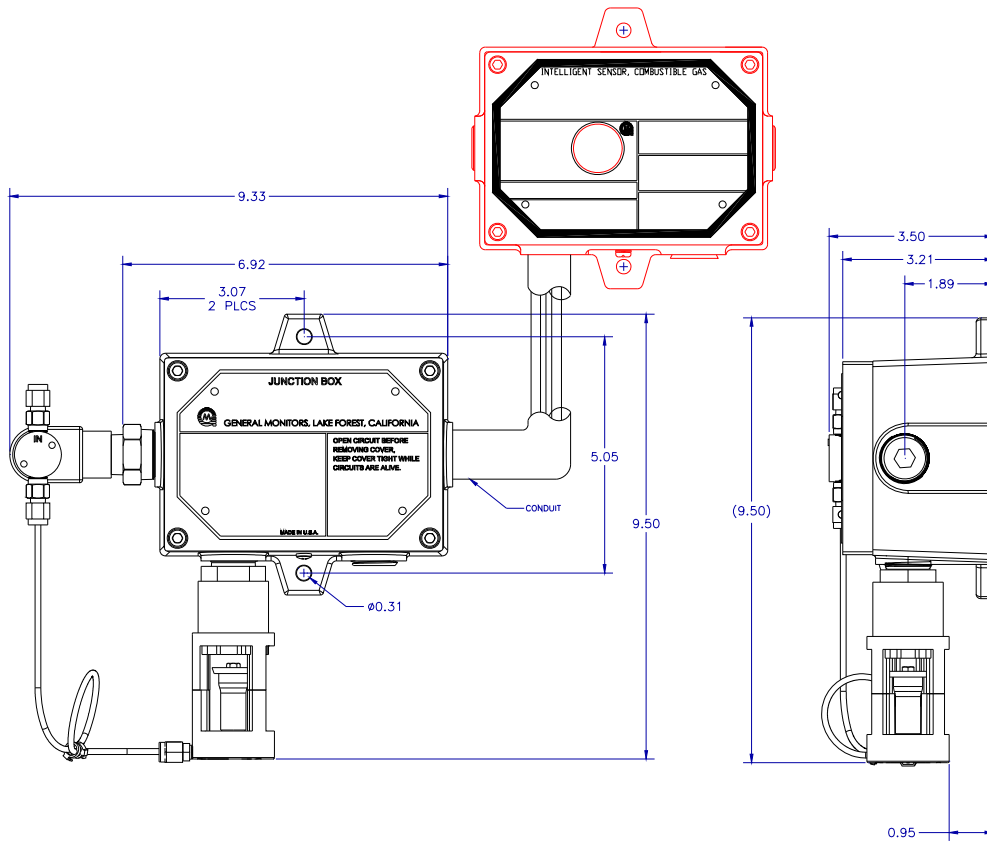

Figure 4: ARGC Remote Installation

Terminal Connections

The terminal blocks (TB) are located inside the housing and can be accessed by removing the cover. A label on the inside of the housing cover provides details of all the terminal connections.



WARNING: Do not connect +24 VDC to TB1. Damage to the electronics or sensor may result.

It is recommended that a minimum three-wire shielded cable be used for making the power and 0-20mA Output connection on TB2 of the S4000CH. It is also recommended that separate two-wire shielded twisted pair cables be used for making the Modbus connections. The spring type terminal block accepts 14 AWG to 20 AWG and the screw type terminal block accepts 12 AWG to 18 AWG stranded or solid wire. Each wire should be stripped before wiring the S4000CH intelligent sensor. To connect wiring to the spring type terminal block, insert a screwdriver into the orange tab and press down (Figure 5), opening the terminal. Insert the wire into the terminal and release the orange tab, clamping the wire in the terminal. Check the hold of the wire by GENTLY tugging it to ensure it is locked in.

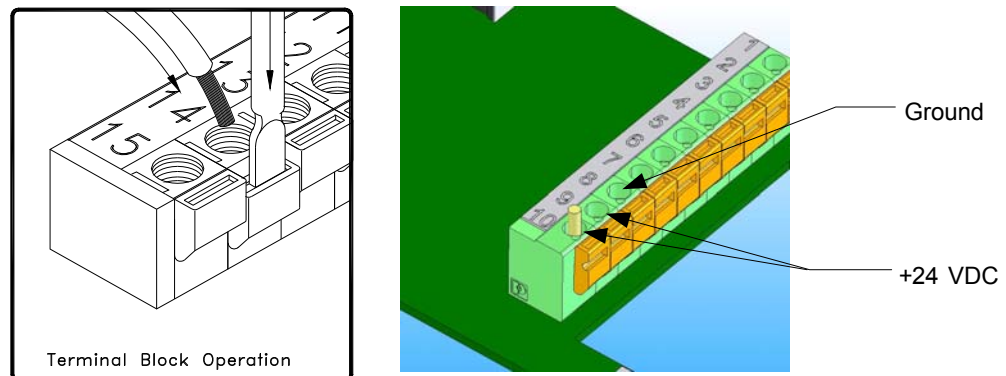

Figure 5: Spring Type Terminal Block Operation

To connect wiring to the screw type terminal block, (Figure 6) use a screwdriver to loosen the top screw counter clockwise. Insert the wire into the terminal and tighten the top screw clockwise. Check the hold of the wire by GENTLY tugging it to ensure it is locked in.

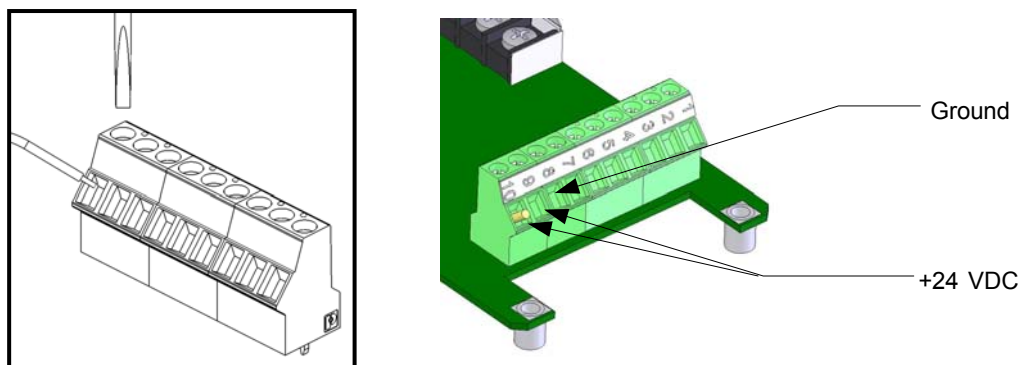

Figure 6: Screw Type Terminal Block Operation

NOTE: Power must remain disconnected until all other wiring connections have been made.

The maximum distance between the S4000CH and the power supply is 3430 feet or 1040 meters (each cable run should be as short as possible). See Section 7.3.4 for cable length specifications.

Connect +24 VDC to TB2, position 9. Connect the ground or common to TB2, position 8.

To connect the analog signal, please refer to Section 3.5.4.

General Monitors recommends that the S4000CH Intelligent Sensor be calibrated one hour after start-up, and that the calibration be checked at least every ninety (90) days to ensure system integrity.

The instrument is now ready to operate. Please consult the manual for more information on the instrument's many features.

NOTE: If you have any problems in the set-up or testing of the detector, please refer to the "Troubleshooting Section", or call the factory direct. See Section 5.2.

1.0 Introduction

1.1 Protection for Life

General Monitors' mission is to benefit society by providing solutions through industry leading safety products, services, and systems that save lives and protect capital resources from the dangers of hazardous flames, gases, and vapors.

This manual provides instruction for installing and operating General Monitors' Model S4000CH for combustible gas detection. While the S4000CH is easy to install and operate, this manual should be read in full and the information contained herein understood before attempting to place the system in service.

The safety products you have purchased should be handled carefully and installed, calibrated, and maintained in accordance with the respective product instruction manual. Remember these products are for your safety.

1.2 Special Warnings

The Model S4000CH Intelligent Sensor contains components, which can be damaged by static electricity. Special care must be taken when wiring the system to ensure that only the connection points are touched.



WARNING: Toxic, combustible and flammable gases and vapors are very dangerous. Extreme caution should be used when these hazards are present.

DO NOT OPEN WHEN AN EXPLOSIVE ATMOSPHERE IS PRESENT. READ AND UNDERSTAND INSTRUCTION MANUAL BEFORE OPERATING OR SERVICING. OPEN CIRCUIT BEFORE REMOVING COVER. POTENTIAL ELECTROSTATIC CHARGING HAZARD – USE ONLY DAMP CLOTH FOR CLEANING.

NE PAS OUVRIR UN PRÉSENCE D'ATMOSPHÈRE EXPLOSIVE. LIRE ET COMPRENDRE MANUEL D'INSTRUCTIONS AVANT D'UTILISER OU SERVICE. OUVRIR LE CIRCUIT AVANT D'ENLEVER LE COUVERCLE. DANGER POTENTIEL ÉLECTROSTATIQUE DE CHARGE – UTILISATION UNIQUEMENT UN CHIFFON HUMIDE POUR LE NETTOYAGE.

SPECIAL CONDITIONS OF SAFE USE PERTAINING TO ATEX/IECEX INSTALLATIONS:

The S4000CH has been subjected to performance testing in accordance with EN 60079-29-1 and therefore may be used as a safety related device as defined by ATEX Directive 94/9/EC Annex II clause 1.5.

When alternative detector elements are utilized, they shall only be mounted remotely in a suitable certified enclosure in accordance with requirements of their respective certificates and relevant local requirements. The associated cable shall be connected to the Intelligent Gas Sensors using a suitably certified cable entry device with a 3/4" thread form.

The Universal Gas Sensor (11159-XX) is suitable for use with the following enclosure types and service/temperature ranges that are dependent on the type of cement used in their

construction; therefore, they shall only be used with the enclosure type and where the surface temperature, at the point of mounting, is as detailed below:

Cement	Ambient Range	Enclosure Type
2850FT Cat 11, 2762 Cat 17	-40°C to +70°C	Enclosures that are certified by a notified body and satisfy the requirements of the current edition of EN 60079-1 or EN 60079-7 and European Directive 94/9/EC.
2850FT Cat 11	-40°C to +120°C	Enclosures that are certified by a notified body and satisfy the requirements of the current edition of EN 60079-7 and European Directive 94/9/EC.
2762 Cat 17	-40°C to +180°C	Enclosures that are certified by a notified body and satisfy the requirements of the current edition of EN 60079-7 and European Directive 94/9/EC.

The Universal Gas Sensor (11159-XX), when tested in accordance with clause 15.4.2.1 of EN 60079-1, produced a maximum surface rise of 26.3 K. This value should be considered when the component is incorporated into equipment.

The Universal Gas Sensor (11159-XX), utilizing Types 2850FT Cat 11 and 2762 Cat 17 cement shall only be fitted to enclosures having a maximum reference pressure of 9.6 bar.

1.3 System Integrity Verification

Commissioning Safety Systems

Before power up, verify wiring, terminal connections and stability of mounting for all integral safety equipment including, but not limited to:

- Power supplies
- Control modules
- Field detection devices
- Signaling / output devices
- Accessories connected to field and signaling devices
- Remote Gas Calibrator (RGC) / Automatic Remote Gas Calibrator (ARGC)

After the initial application of power (and any factory specified warm-up period) to the safety system, verify that all signal outputs, to and from devices and modules, are within the manufacturer's specifications. Initial testing should be performed per the manufacturer's recommendations and instructions.

Proper system operation should be verified by performing a full, functional test of all component devices of the safety system, ensuring that the proper levels of alarming occur. Fault/Malfunction circuit operation should be verified.

Periodic Testing of Field Devices

Periodic testing/calibrating should be performed per the manufacturer's recommendations and instructions. Testing/calibrating procedures should include, but not be limited to:

- Verify integrity of all optical surfaces and devices

When testing produces results outside of the manufacturer's specifications, replacement of the suspect device(s) should be performed as necessary. Maintenance intervals should be independently established through a documented procedure, including a maintenance log maintained by plant personnel or third party testing services.

Periodic System Verification

The following system verifications should be performed at least annually:

Verify wiring, terminal connections and stability of mounting for all integral safety equipment including, but not limited to:

- Power supplies
- Control modules
- Field detection devices
- Signaling / output devices
- Accessories connected to field and signaling devices
- RGC or ARGC (if purchased)

2.0 Product Description

2.1 General Description

The Model S4000CH is an intelligent sensor for the detection of combustible gases and vapors. The microprocessor-based electronics process information at the sensor site within an explosion-proof housing.

A digital display provides indications and display codes that can be viewed through a window in the cover. A red LED above the digital display signifies an ALARM condition, while a red LED below the digital display signifies a WARN condition. Analog signal (4-20 mA) and relays provide remote and/or discrete indications of the sensor's operation. Optional dual redundant Modbus, HART or HART and single Modbus provide digital communication.

The Model S4000CH Intelligent Sensor is rated explosion-proof for use in the following hazardous areas:

- CSA/FM: Class I, Division 1, Groups B, C, D and Class I, Zone 1, IIB+H₂
- ATEX/IECEX: Zone 1, Group IIB + H₂ and Zone 21, Group IIIC



Figure 7: Model S4000CH Intelligent Sensor

NOTE: The image in Figure 7 is for reference only. See section 7.3 for actual product specifications.



Figure 8: Model S4000CH Intelligent Sensor with ARGC

NOTE: The image in Figure 8 is for reference only. See section 7.3 for actual product specifications.



Figure 9: ARGC Remote Junction Box Assembly (P/N 80155-1)

3.0 Installation

3.1 Receipt of Equipment

All equipment shipped by General Monitors is pre-packed in shock absorbing containers, which provide protection against physical damage (original containers should be kept for future shipping or storage needs).

Shipping container contents should be carefully removed and checked against the packing list. If any damage has occurred, or there is any discrepancy in the order, please notify General Monitors as soon as possible.

All correspondence with General Monitors must specify the equipment part number and serial number.

The factory tests each unit; however, a complete system checkout is suggested upon initial installation to ensure system integrity.



WARNING: Installation and maintenance must be carried out by suitably skilled and competent personnel only.

3.2 Tools Required

- “5 mm” Allen head wrench to remove enclosure lid (included with gas detector).
- Flat-head screwdriver maximum 3/16” (5 mm) width for terminal block connections (included with gas detector).
- Adjustable wrench for conduit or cable gland connections (not included).

3.3 Choosing Product Locations

There are no standard rules for sensor placement, since the optimum sensor location is different for each application. The customer must evaluate conditions at the facility to make this determination. Generally, the Model S4000CH Intelligent Sensor should be easily accessible for calibration checks.

- The sensor should be mounted pointing down to prevent water build-up on the sensor head.
- The sensor should not be placed where contaminating substances may coat it.
- Although the S4000CH is RFI resistant, it should not be mounted in close proximity to radio transmitters or similar equipment.
- Locate the S4000CH where prevailing air currents contain the maximum concentration of gas.
- Locate the S4000CH near possible sources of gas leaks.
- Observe the S4000CH's temperature specification and locate the unit away from concentrated sources of heat.

- Sensors should be mounted in an area that is as free from wind, dust, water, shock, and vibration as possible. See Section 7.3.6 for the environmental specifications of the unit. If the sensor cannot be located away from dust and rain, then we recommend the use of our splashguard GM P/N 10395-1 to help protect the sensor.

Sensors may be adversely affected by prolonged exposure to certain materials. Loss of sensitivity or corrosion may be gradual if such materials are present in low concentrations, or it may be rapid at high concentrations. The more important materials adversely affecting sensors are:

- Constant presence of high concentrations of hydrogen sulfide (H₂S) gas
- Silicones (often contained in greases and aerosols)
- Halides, compounds containing fluorine, chlorine, bromine and iodine
- Heavy metals, e.g. tetraethyl lead
- Caustic and acidic liquids and vapors

The presence of poisons and contaminants in an area does not necessarily preclude the use of a Model S4000CH intelligent sensor. The feasibility of using a sensor in such areas must be determined by an analysis of the specific factors in each application and General Monitors should be consulted before attempting any such installation.

Sensors used in these areas usually require more frequent calibration checks than normal, and typically have a shorter life. In many such applications, the standard two-year warranty would not apply.



WARNING: General Monitors discourages the painting of sensor assemblies. If the sensor head is painted over, the gas will not be able to diffuse into the sensor. If the assembly cover is painted over, the digital display cannot be read.

3.3.1 Remote Mounting of the Sensor from the Electronics

If it is necessary to remotely mount the sensor from the electronics and the housing, the sensor must be mounted in an explosion-proof rated sensor housing (GM P/N 10252-1 or 10252-3). The 10252-3 sensor housing can be used at temperatures up to 200°C when used with sensor 11159-2. The cable run must be contained in conduit running from the sensor housing to the electronics. See Section 7.3.4 for cable lengths. The maximum cable length to the power supply will be reduced by 10%.

For remote mounting in Canada where the location is classified using the Zone classification system, the sensors must be mounted in sensor housing B13-020, B13-021, or B13-022 as applicable. Only sensors 11159 can be used in this configuration.

General Monitors has accessories that help with remote or difficult to get to locations. The RGC or ARGC facilitate remote gassing.

NOTE: At an upper ambient of +200°C, the accuracy of the gas readings will be negatively impacted. For example, in an atmosphere of 10% LEL gas, the sensor will read approximately 2% LEL; at 25% LEL, the sensor will read approx. 15%; at 50% LEL, the sensor will read approx. 34%; at 75% LEL, the sensor will read approx. 59%, at 85% LEL, the sensor will read approx. 67%.

3.4 Mounting and Wiring



WARNING: Unused cable entry holes must be sealed with a suitably certified ATEX or IECEx explosion-proof stopping plug. Red caps supplied by General Monitors are for dust protection only, and must not be left on the unit when installed.

WARNING: Conduits must be sealed within 18 inches of the enclosure.

The outline and mounting dimensions for the S4000CH (Figure 10) should be used when making installation determinations. A complete list of the mechanical specifications can be found in Section 7.3.2.

To prevent possible corrosion due to moisture or condensation, it is recommended that the conduit connected to the S4000CH housing contain a drain loop.

NOTE: For ATEX and IECEx applications, conduit connections must only be made via suitably certified ATEX (or IECEx as appropriate) conduit stopping boxes.

Information on Class I Division 1 and Zone 1 wiring methods can be found in the NEC and CEC.



WARNING: Acetic acid will cause damage to metal components, metal hardware, ceramic IC's, etc. If damage results from the use of a sealant that outgases acetic acid (RTV silicone), the warranty will be void.

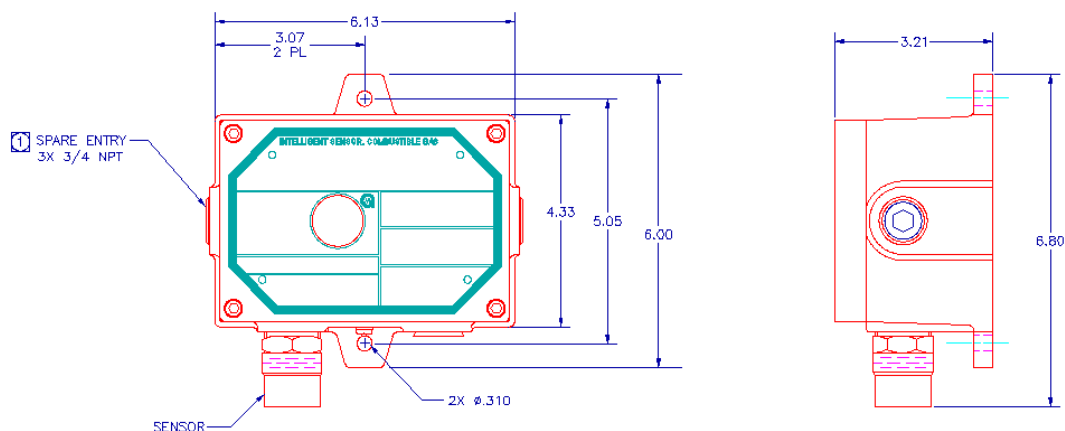

Figure 10: Outline and Mounting Dimensions in inches

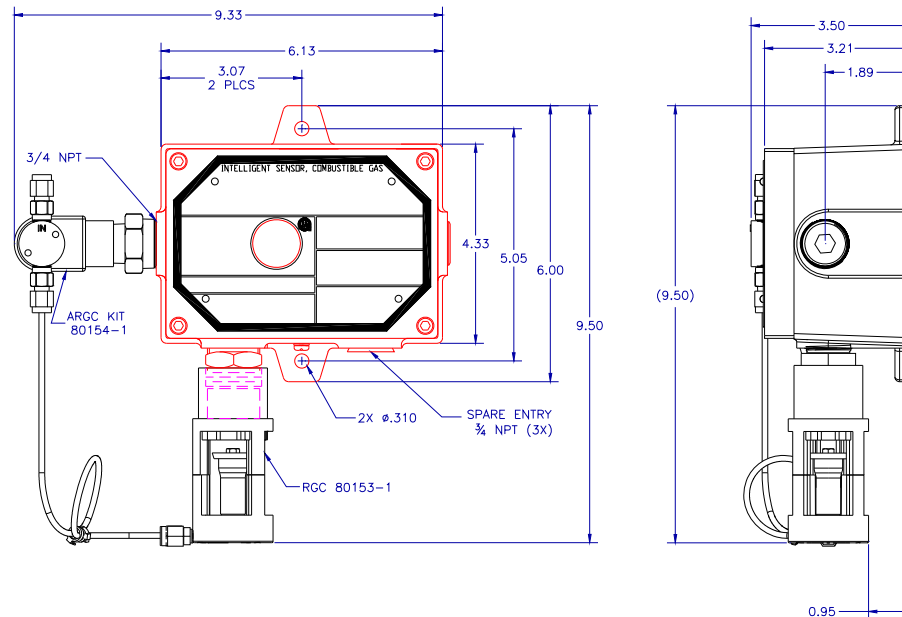

Figure 11: Outline and Mounting Dimensions (ARGC) in inches

Once correctly installed, the S4000CH requires little or no maintenance, other than periodic calibration checks to ensure system integrity. General Monitors recommends that a calibration schedule be established and followed.

NOTE: The S4000CH full two-year warranty will be voided if customer personnel or third parties damage the S4000CH during repair attempts.

Sensor heads exposed to the elements may require the accessory mounting threads to be lubricated. Grease must not be used. As an alternate, PTFE (Teflon) tape may be used on sensor accessory threads.

NOTE: Do not use any material or substance on threads that contact the sensor housing.

The removal of particulate matter from sensor accessories may be done through the use of an appropriate halogen-free solvent. Water and ethanol are examples of suitable solvents. The accessories should be thoroughly dried with compressed air, if necessary, before refitting to the sensor body.

3.5 Terminal Connections

The terminal blocks (TB) are located inside the housing and can be accessed by removing the cover. A label on the inside of the housing cover provides details of all the terminal connections.

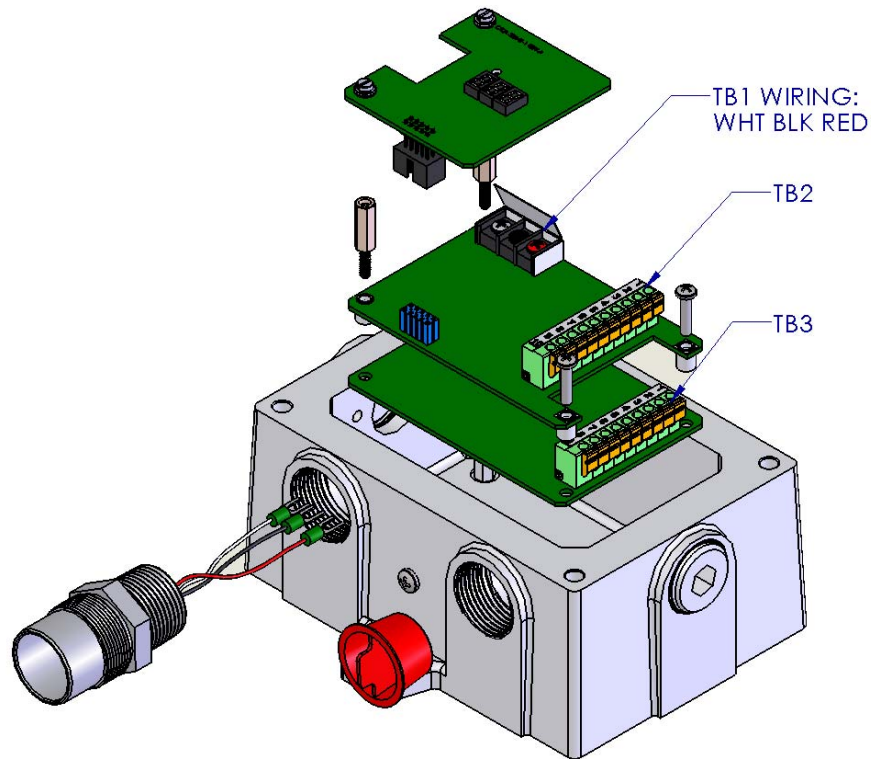

Figure 12: S4000CH Terminal Block Locations

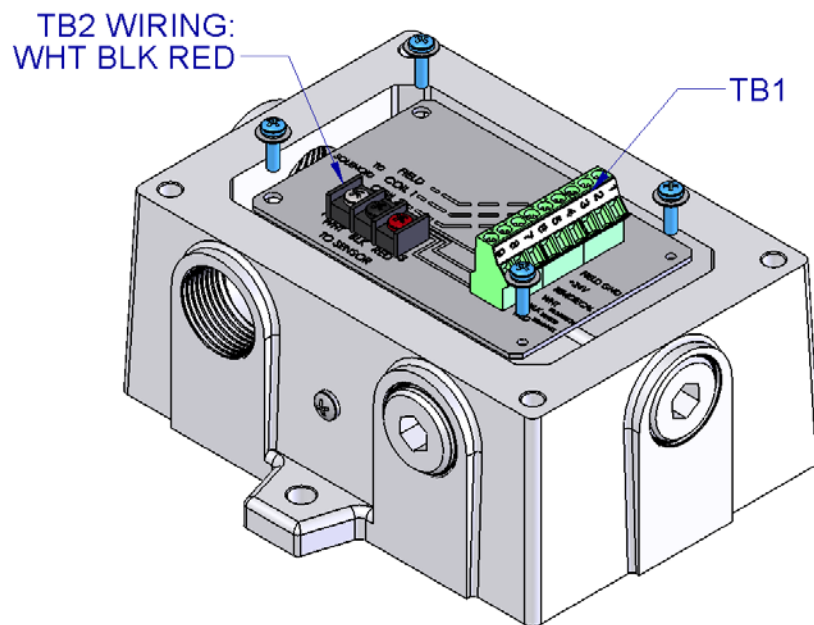

Figure 13: Remote Junction Box Terminal Block

3.5.1 Terminal Block TB1 – Sensor Connections

TB1 contains the three sensor connections, white (W), black (B), and red (R). Remove the display board by loosening the two captive screws on the board and lifting it straight up. Connect the color-coded wires from the combustible sensor to the matching colored terminals on TB1. The label on the inside of the cover can serve as a guide. Replace the display board by pressing it into place, and tightening the two captive screws.



WARNING: Do not connect +24 VDC to TB1. Damage to the electronics will result.

3.5.2 Terminal Block TB2 – Power and Signal Connections

TB2 contains the connections for Power, Relay Reset, Remote Calibration/ARGC, Modbus and 0-20 mA Output Signal. The terminal connections are as follows:

TB2 position	Function
1	0-20 mA Output
2	CH1 Modbus -
3	CH1 Modbus +
4	CH2 Modbus -
5	CH2 Modbus +
6	Remote Calibration/ARGC
7	Relay Reset
8	COM
9	+24 VDC Power
10	+24 VDC Power for ARGC

Table 1: TB2 Power and Signal Connections

It is recommended that a minimum three-wire shielded cable be used for making the power and 0-20mA Output connection on the S4000CH. It is also recommended that separate two-wire shielded twisted pair cables be used for making the Modbus connections. The spring type terminal block accepts 14 AWG to 20 AWG and the screw type terminal block accepts 12 AWG to 18 AWG stranded or solid wire. Each wire should be stripped before wiring the S4000CH. To connect wiring to the spring type terminal block, insert a screwdriver into the orange tab and press down (Figure14), opening the terminal. Insert the wire into the terminal and release the orange tab, clamping the wire in the terminal. Check the hold of the wire by GENTLY tugging it to ensure it is locked in.

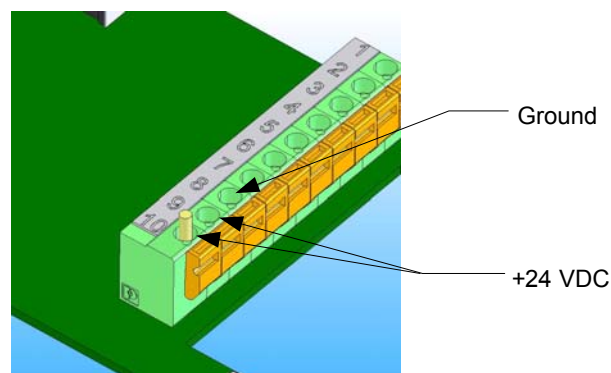
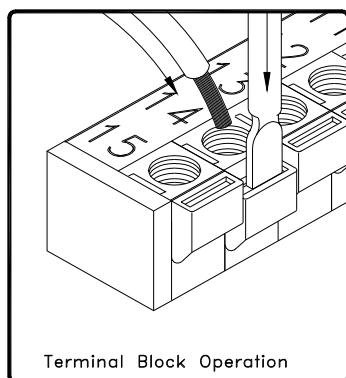

Figure 14: Spring Type Terminal Block Operation

To connect wiring to the screw type terminal block, (Figure 15) use a screwdriver to loosen the top screw counter clockwise. Insert the wire into the terminal and tighten the top screw clock wise. Check the hold of the wire by GENTLY tugging it to ensure it is locked in.

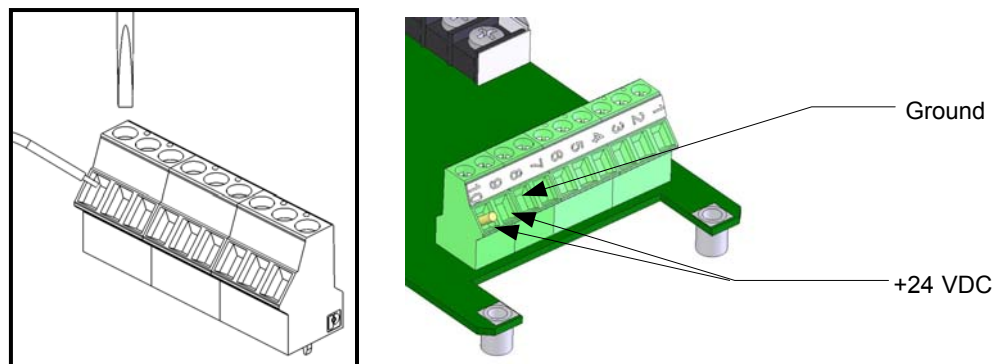

Figure 15: Screw Type Terminal Block Operation

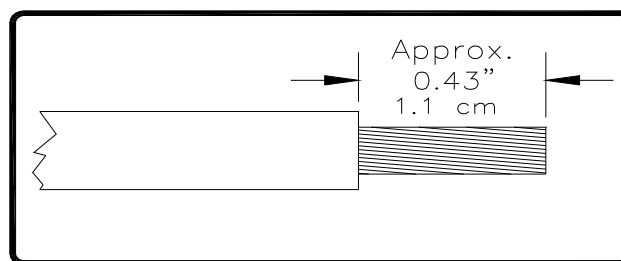

Figure 16: Wire Strip Length

NOTE: Up to 14 AWG wire can be used if it is carefully stripped (Figure 16).

3.5.3 DC Power and COM Connections

The customer must provide primary DC power unless one of the following General Monitors modules is being used with the S4000CH:

- TA102A trip amplifier module with a PS002 power supply & relay module

The following General Monitors modules provide power connections for the S4000CH, but need a customer supplied DC source:

- DC110 Eight-Channel Readout/Relay Display Module
- TA102A Trip Amplifier Module without a PS002

Since the S4000CH is designed to operate continuously, a power switch is not included, in order to prevent accidental system shutdown.

NOTE: Power must remain disconnected until all other wiring connections have been made.

See Section 7.3.4 for cable length specifications.

To connect +24 VDC to the S4000CH, connect the red wire (+24V) to TB2, position 9. Connect the black wire (Ground) to TB2, position 8.

For making power and ground connections to display devices see Table 2 and Table 3.

FROM	TO	
S4000CH	DC110	TA102A
TB2-8 "COM"	Rear COMMON	Rear Pin 30d or 30z

Table 2: Ground or Common Connections

FROM	TO	
S4000CH	DC110	TA102A
TB2-9 "+24 VDC"	Rear CH 1 – 8 24V	Rear Pin 28d or 28z

Table 3: Power Connections

3.5.4 Analog Signal Connections

The S4000CH Intelligent Sensor provides a 4 to 20 mA output signal. It can be sent up to 9000 feet (2740 meters) to a General Monitors readout/relay display module, or an industrial analog to digital converter, or a computer-based monitor, a PLC, a DCS, etc. The 4 to 20 mA signal provides for control room or other locations remote to the S4000CH to display indications of operation and alarm conditions.

To connect the 4 to 20 mA output signal with another unit, connect the wire into TB2, position 1, labeled 4-20 mA OUT. For making output signal connections to display devices (Table 4), refer to the specific manual for that device.

NOTE: Power must remain disconnected until all other wiring connections have been made.

FROM	TO	
S4000CH	DC110	TA102A
TB2-1 4-20 mA Output	Rear CH 1 – 8 4-20 mA	Rear Pin 26d or 26z

Table 4: Analog Signal Connections

If a device other than a General Monitors readout/relay display module is being used, the DC ground, COM, of both systems must be connected together.

3.5.5 ARGC Terminal Connections

The solenoid valve is not polarized. Either wire can go to either terminal. One wire goes to the Calibrate Input/ARGC Output and the other wire goes to the +24 volts.

CAUTION: When the ARGC is used it cannot be used as a calibration input.

3.5.6 Terminal Block TB3 – Relay Connections

TB3 contains the connections for the Relay Contacts (optional). The function for the Warn and Alarm Relay connections vary according to the normal state of the relay. Use the following as a guide for determining the Normally Open (**NO**) and the Normally Closed (**NC**) contact:

TB3 position	Relay Contact(De-Energized)	Relay Contact (Energized)
1	Normally Closed	Normally Open
2	Common	Common
3	Normally Open	Normally Closed

Table 5: Alarm Relay Connections

TB3 position	Relay Contact (De-Energized)	Relay Contact (Energized)
4	Normally Closed	Normally Open
5	Common	Common
6	Normally Open	Normally Closed

Table 6: Warn Relay Connections

TB3 position	Relay Contact (Energized)
7	Normally Open
8	Common
9	Normally Closed

Table 7: Fault Relay Connections

NOTE: Fault relay is normally energized. Relay will change state after power up.



WARNING: Contact with PCB components should be avoided to prevent damage by static electricity. All wire connections are made to the Terminal Blocks. Relay contacts must be protected against transient and over voltage conditions (Figure 17).

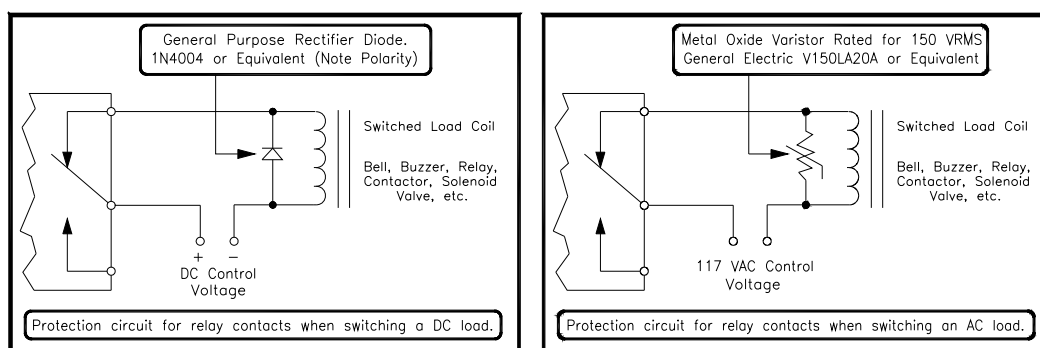

Figure 17: Relay Protection for DC and AC Loads

European Union (EU) Approved Applications: The ALARM relay contact ratings are 8 A, 30 V RMS/42.4 V peak or 8 A @ 30 VDC resistive max.

North American Approved Applications: The ALARM relay contact ratings are 8 A @ 250 VAC and 8 A @ 30 VDC resistive max.

3.5.7 European Union (EU) Approved Applications

Interconnecting cables must have an overall screen or screen and armor. Cables BS5308 Part 2, Type 2; or equivalent, are suitable. Note that the terms 'screen' and 'shield' are equivalent for the purpose of this manual. The cable armor must be terminated in a suitable cable gland, at the detector, to ensure a positive electrical connection.

3.5.8 Cable Termination in the Non-Hazardous Area

- The cable **armor** must be connected to **safety earth** in the safe area.
- The cable **screen** (drain wire) must be connected to an **instrument earth** in the safe area.
- The power supply **0V return** must be connected to an **instrument earth** in the safe area.
- The interconnecting cables should be segregated from power and other noisy cables. Avoid proximity to cables associated with radio transmitters, welders, switch mode

power supplies, inverters, battery chargers, ignition systems, generators, switch gear, arc lights and other high frequency or high power switching process equipment. In general, maintain separation of at least 1 meter between instrument and other cables. Greater separations are required where long parallel cable runs are unavoidable. Avoid running instrument cable trenches close to lightning conductor earth pits.

- Complete all cable insulation testing before connecting the cable at either end.



WARNING: Under **NO** circumstances should equipment be connected or disconnected when under power. This is contrary to hazardous area regulations and may lead to serious damage to the equipment. Equipment damaged in this manner is not covered under warranty.

3.6 Maintaining the X/P Integrity

The S4000CH intelligent sensor is rated explosion-proof for use in the following hazardous locations:

- CSA/FM: Class I, Division 1, Groups B, C, D and Class I, Zone 1, IIB+H₂
- ATEX/IECEX: Zone 1, Group IIB+ H₂

Some of the factors that influence the explosion-proof integrity of the S4000CH housing are:

- Strength of the enclosure material
- Thickness of the enclosure walls
- Flame path between the housing and cover
- Flame path of threaded joints

The acceptable limits for explosion-proof housings that are used in hazardous locations are defined in CSA Standard C22.2 No.30, FM 3615, and EN/IEC 60079-1.

Anytime the cover of the S4000CH housing is removed, or the cover bolts are loosened, the flame path between the lid and the housing is affected. If power is to be left on while removing the cover or loosening the cover bolts on the S4000CH, it will be necessary to declassify the area.

When replacing the cover, the gap between the lid and the housing should be less than .0015 inch (.038 mm). Make sure that the flame-path is clear of dirt and debris before replacing the cover. This can be verified by tightening the cover bolts to a torque setting of 50 inch-pounds or by using a feeler gauge to ensure the gap between the cover and the housing is less than .0015 inch (.038 mm).

There are four entry holes, one each on the left and right sides, and two on the bottom of the S4000CH housing. These holes are dedicated for the sensor and conduit/cable. Each hole is tapped for 3/4" NPT threads. If a particular entry hole is not used, it must be plugged during operation in the field. The factory installs plugs in the unused entry holes, except one. A red plastic cap is placed into this remaining hole and must be removed before conduit can be attached to the housing.

The S4000CH will have the following items placed in the four entry holes, at the factory:

- A sensor, if present (otherwise a red plastic cap)
- Two aluminum stopping plugs
- A red plastic cap

The sensor and aluminum-housing plugs have seven threads. Each of these components is screwed into the housing using five to seven turns. If any of these components must be replaced, apply five to seven turns upon replacing the component to ensure the explosion proof integrity of the device is maintained.

3.7 Start-Up Checklist

Prior to starting the system, verify the following:

- Inhibit any external devices, such as trip amplifiers, PLC's, or DCS systems.
- Verify that the optional settings are set for the desired configuration.
- Verify that the unit is properly mounted. Ensure the conduit/cable gland entries are pointed downward.
- Verify that the signal wiring is correct.
- Verify that the power supply is connected properly. The S4000CH is powered by +24 VDC (20 to 36 VDC voltage range). The detector will output a low voltage (F6) fault at 18.5 VDC or below.
- Make sure the lid is securely installed or the area has been declassified.
- Calibrate one hour after start-up.

3.8 Start-Up

Before applying power to the system for the first time, all wiring connections should be checked for correctness and the housing cover replaced. Upon first power-up the sensor may take up to fifteen minutes to stabilize.

At the initial application of power, the unit will test all of the LED segments by displaying "88.8". The software revision letter will then be displayed for a few seconds. The unit will then enter a fifty second Start-Up Mode. During this period, the display will read "SU". The unit will then enter Operational Mode, and the current gas concentration at the sensor will be displayed. For details on calibrating and gas checking the unit, see Sections 3.13 and 3.14.

3.9 Relay Reset

If the Warn and Alarm relays are configured as latching, they must be manually reset, after an alarm occurs. This can be accomplished by four different methods:

- The relays can be reset via the magnetic switch using a magnet. Place the magnet over the GM logo on the cover of the unit. After three seconds, the display will show "rSt". Remove the magnet at this time and the relays will be reset (**Figure 18**).

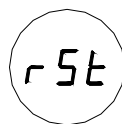
**Figure 18: Relay Reset**

- The relays can be reset via the Remote Reset input terminals on TB2. Connect a normally open switch between terminal TB2-7 and TB2-8. Closing the switch momentarily will reset the relays. General Monitors explosion-proof switch, P/N 30051-1, can be used for this purpose. See Section 7.6 for ordering instructions.
- The relays can be reset via the Modbus Interface (Section 6.0).
- The relays can be reset via the HART communication.

NOTE: Red LED's above and below the digital display indicate that the Alarm and Warn relays are active. Latching relays can only be reset if the gas concentration has fallen below the respective relay set point.

3.10 User Selectable Options

The S4000CH includes many selectable options to provide the user with the most flexible combustible gas detector possible. These options include Adjustable Calibration Level, Warn and Alarm Relay Set Points and Configuration, and Modbus Communications Settings. These allow the unit to operate with a wide variety of PLC and DCS Systems. The following sections explain the available options and how they can be customized. A flow diagram is included to help the user in understanding the process of reviewing and changing the available options (Figure 19).

NOTE: If the unit was ordered without relays or Modbus communications, changing relay or Modbus settings will have no effect on the operation of the unit.

3.11 Available Separate Purchase Options

Modbus

- Dual Redundant Modbus
- Single Modbus and HART

HART

- HART is a Master to Slave -One to One communication channel.

RGC

- The Remote Gas Calibrator (RGC) is an accessory that allows remote calibration. With this device, the user turns on and off the calibration gas manually.

ARGC

- The ARGC accessory is an Automatic Remote Gas Calibrator (ARGC). It is a kit with a RGC, a solenoid valve and all the required fittings from the valve to the RGC.

Remote Mounted ARGC

- The ARGC is also available in a standard GM explosion proof box. This provides terminal strips for all the connections to activate the ARGC.

3.11.1 Model S4000CH User Menu Structure

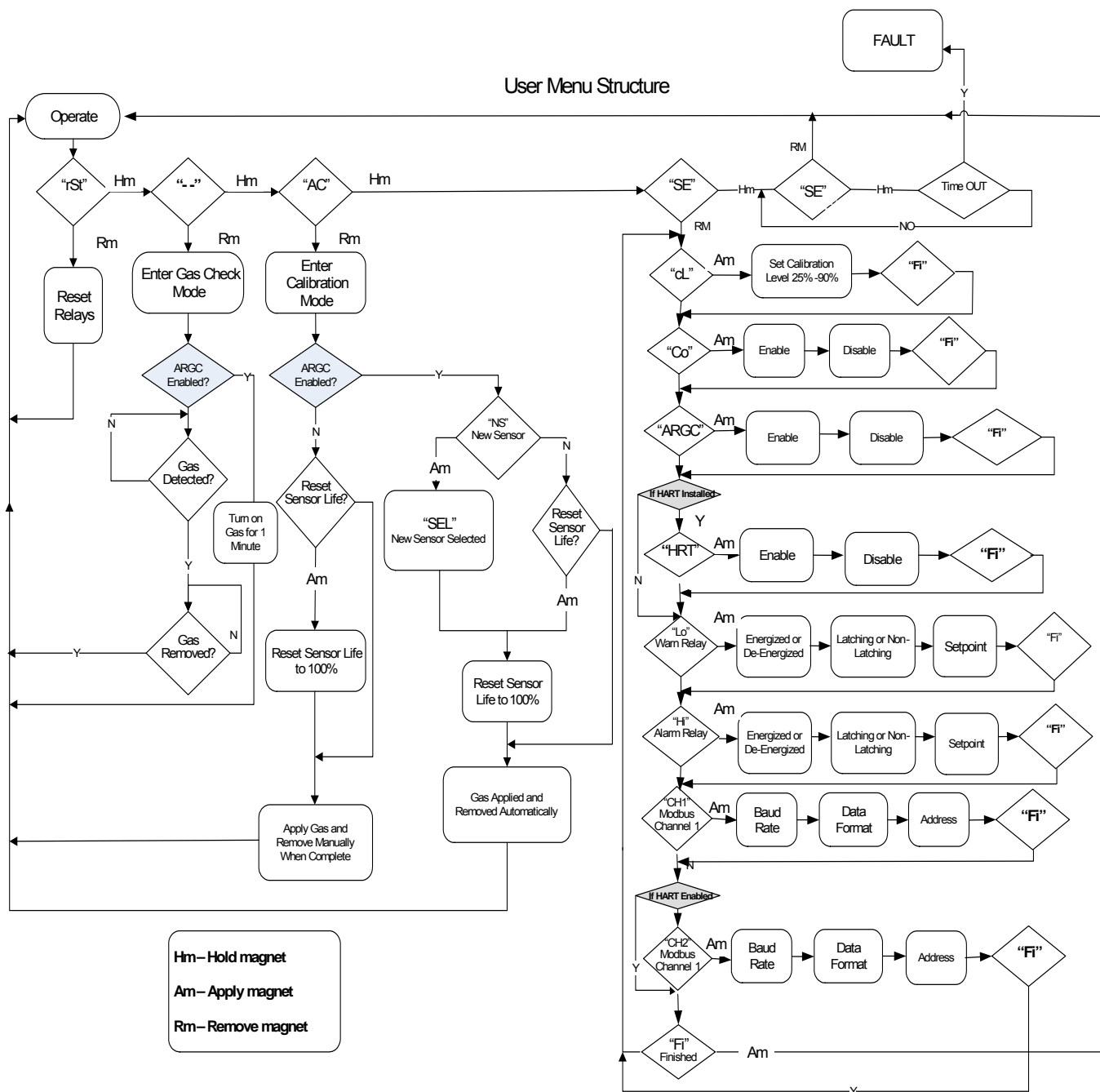

Figure 19: User Menu Structure

NOTE: “Co” represents Calibration Output. When “Co” is enabled and calibration is successful, the analog output goes from 1.5 mA to 3.2 mA for 5 seconds, settling at the desired value of 4 mA. This option is commonly used with the General Monitors HazardWatch system.

3.11.2 Calibration Level

NOTE: Refer to Section 3.14.1 for the calibration procedure.

To adjust the calibration level of the S4000CH, apply the magnet to the GM logo on the cover of the unit, until “SE” is displayed, then remove the magnet. This puts the unit into Setup Mode. After a few seconds “cL” will be displayed. Apply and remove the magnet to adjust the calibration level. The current calibration level will be displayed. To change the calibration level, apply and remove the magnet repeatedly, until the desired level is displayed. Holding the magnet in place will cause the display to advance rapidly after a few seconds. Once the desired value is displayed, wait 3 seconds and “Fi” will be displayed. Apply and remove the magnet to return to the next level of the Setup menu. When “Fi” is displayed again, apply and remove the magnet to return to normal operation. **The default calibration level is 50% LEL.**

3.11.3 Warning Relay Settings

To adjust the Warning Relay Settings of the S4000CH, apply the magnet to the GM logo on the cover of the unit until “SE” is displayed, then remove the magnet. This puts the unit into Setup Mode. After a few seconds “Lo” will be displayed. Apply and remove the magnet to change the Warning or “Low” alarm settings.

First, the Energized/De-Energized state of the relay is shown by either “En” or “dE” being displayed, respectively. Apply and remove the magnet until the desired state is displayed.

After a few seconds, the Latching/Non-Latching state of the relay is shown by either “La” or “nL”. Apply and remove the magnet, until the desired state is displayed.

After a few seconds, the current Warning relay set point is displayed. Apply and remove the magnet, until the desired set point is displayed. Once the desired set point value is displayed, wait 3 seconds and “Fi” will be displayed. Apply and remove the magnet to return to the next level of the Setup menu. When “Fi” is displayed again, apply and remove the magnet, to return to normal operation.

The default Warning Relay Settings are: non-latching, de-energized, 30% LEL set point.

NOTE: The Warn relay set point cannot be set higher than the Alarm Relay set point, or higher than 60% LEL.

3.11.4 Alarm Relay Settings

To adjust the Alarm Relay Settings of the S4000CH, apply the magnet to the GM logo on the cover of the unit until “SE” is displayed, then remove the magnet. This puts the unit into Setup Mode. After a few seconds “Hi” will be displayed. Apply and remove the magnet to change the Alarm or “High” alarm settings.

First, the Energized/De-Energized state of the relay is shown by either “En” or “dE” being displayed respectively. Apply and remove the magnet, until the desired state is displayed.

After a few seconds, the Latching/Non-Latching state of the relay is shown by either “La” or “nL”. Apply and remove the magnet, until the desired state is displayed.

After a few seconds, the current Alarm relay set point is displayed. Apply and remove the magnet until the desired set point is displayed. Once the desired set point value is shown, wait 3 seconds and “Fi” will be displayed. Apply and remove the magnet to return to the next level of the Setup menu. When “Fi” is displayed again, apply and remove the magnet to return to normal operation.

The default Alarm relay settings are: latching, de-energized, 60% LEL set point.

NOTE: The Alarm relay set point cannot be set lower than the Warning Relay set point, or higher than 60% LEL.

3.11.5 Modbus Channel 1 Settings

To change the Modbus Channel 1 settings of the S4000CH, apply the magnet to the GM logo on the cover of the unit until “SE” is displayed, then remove the magnet. This puts the unit into Setup Mode. After a few seconds “CH1” will be displayed. Apply and remove the magnet to change the Modbus Channel 1 settings.

First, the current Baud Rate Modbus Channel 1 is displayed. If another baud rate is to be selected, apply and remove the magnet until the desired baud rate is displayed. The choices are: 19.2k baud “19.2”, 9600 baud “96”, 4800 baud “48”, or 2400 baud “24”.

After a few seconds, the current Data Format for Modbus Channel 1 is displayed. If another data format is to be selected, apply and remove the magnet until the desired data format is displayed. The choices are: 8-N-1 “8n1”, 8-N-2 “8n2”, 8-E-1 “8E1”, or 8-O-1 “8O1”.

After a few seconds, the current address for Modbus Channel 1 is displayed. Apply and remove the magnet until the desired address is displayed. Once the desired address is displayed, wait 3 seconds and “Fi” will be displayed. Apply and remove the magnet to return to the next level of the Setup menu. When “Fi” is displayed again, apply and remove the magnet to return to normal operation. **Default settings for Channel 1 are: address 1, 19.2k baud, 8-N-1.**

NOTE: The address can be adjusted from 1 - 247. Channel 1 and Channel 2 addresses may be the same.

3.11.6 Modbus Channel 2 Settings

To change the Modbus Channel 2 Settings of the S4000CH, apply the magnet to the GM logo on the cover of the unit until “SE” is displayed, then remove the magnet. This puts the unit into Setup Mode. After a few seconds “CH2” will be displayed. Apply and remove the magnet to change the Modbus Channel 2 settings.

First, the current Baud Rate Modbus Channel 2 is displayed. If another baud rate is to be selected, apply and remove the magnet until the desired baud rate is displayed. The choices are: 19.2 kbaud “19.2”, 9600 baud “96”, 4800 baud “48”, or 2400 baud “24”.

After a few seconds, the current Data Format for Modbus Channel 2 is displayed. If another data format is to be selected, apply and remove the magnet until the desired data format is displayed. The choices are: 8-N-1 “8n1”, 8-N-2 “8n2”, 8-E-1 “8E1”, or 8-O-1 “8O1”.

After a few seconds, the current address for Modbus Channel 2 is displayed. Apply and remove the magnet until the desired address is displayed. Once the desired address is displayed, wait 3 seconds and “Fi” will be displayed. Apply and remove the magnet to return to the next level of the Setup menu. When “Fi” is displayed again, apply and remove the magnet to return to normal operation.

Default settings for Channel 2 are: address 2, 19.2k baud, 8-N-1.

3.12 HART/Modbus SELECT

This option is not shown if HART was not purchased for the S4000CH. When HART is selected via setup, the Channel 2 setup is not displayed or available. When Channel 2 is changed from HART to Modbus, the previous settings are used.

NOTE: The address can be adjusted from 1 - 247. Channel 1 and Channel 2 addresses may be the same.

3.13 Gas Check Mode

The sensor response can be checked without activating external alarms by placing the S4000CH in Gas Check Mode. In this Mode, the alarm relays are inhibited and the analog output is fixed at 1.5 mA. The display will show the gas concentration level.

3.13.1 Calibration Check

Place the magnet over the GM logo on the cover of the S4000CH. Remove the magnet when a flashing pair of bars, “- -” (Figure 20) appears on the display (about ten seconds). Apply the test gas to the sensor; the value of the gas concentration will be indicated by the flashing display, and should stabilize in one to two minutes.



Figure 20: Calibration Check

When the reading has stabilized and the test is complete, remove the gas and the unit will return to normal operation when the concentration drops below 5% full-scale.

If the ARGV is installed and enabled, the gas will be turned on and then automatically turned off 1 minute later unless Calibration Mode is entered. Once in Calibration Mode, calibration will take control of the ARGV.

If, after the reading has stabilized, the sensor is to be calibrated, simply apply the magnet to the GM logo on the housing cover, and the unit will enter Calibration Mode.

Gas Check Mode can be aborted if gas has not been applied to the sensor. Simply reapply the magnet to the GM logo on the cover and the unit will return to normal operation.

NOTE: The test gas concentration must be at least 10% full-scale before the unit will complete the gas check sequence. If the S4000CH is placed in the Gas Check Mode and no gas is applied for six minutes, the unit will revert to a Fault (F9) condition. Re-applying the magnet over the GM logo will return the unit to normal operation. If the ARGV mode is enabled, and the S4000CH is placed in the Gas Check mode and no gas is applied for 1 ½ minutes, the unit will revert to a fault (F12) condition. Re-applying the magnet over the GM logo will return the unit to normal operation.

3.14 Calibration

General Monitors recommends that the S4000CH Intelligent Sensor be calibrated one hour after start-up, and that the calibration be checked at least every ninety (90) days to ensure system integrity. Frequent calibration checks ensure the integrity of the life protecting equipment.

The above statement is not intended to discourage the customer from checking calibration more frequently. Frequent calibration checks are recommended for environments that have problems, such as mud collecting on the sensor head, sensors accidentally being painted over, etc.

General Monitors recommends that a calibration schedule be established and followed. A logbook should also be kept, showing calibration dates and dates of sensor replacement.

3.14.1 Calibration Procedure

There are three methods for calibrating the S4000CH: Manually, with an RGC, or with an ARGV.

NOTE: If the RGC or ARGV is not installed, the S4000CH calibration is identical to the S4000C.

NOTE: If the Catalytic bead sensor is fitted with a splash guard, calibration must be performed with the splash guard in place.



WARNING: General Monitors recommends calibrating the S4000CH with 50% LEL of the gas being detected. This provides the most accurate calibration, since the S4000CH is optimized for this concentration. The accuracy of the calibration may be reduced by using a different calibration level, and this inaccuracy will increase as the calibration level varies from 50% LEL.

If it is suspected that gases are present, it will be necessary to purge the sensor environment with zero air. If zero air is not available, cover the sensor for about thirty seconds before applying the calibration gas. Zero air is air that is hydrocarbon free.

Entering Calibration Mode disables the alarm circuits by sending a 1.5 mA output signal and disabling the Warn and Alarm relays, if present. This will also prevent activation of the remote relay contacts when using a General Monitors Readout/Relay Display Module with the S4000CH.

To enter Calibration Mode, place the magnet over the GM logo on the cover of the unit (Figure 7) and hold it there until “AC” (Figure 21) appears on the display (about ten seconds). The display will flash the remaining sensor life (Section 3.14.4) for about ten

seconds, while the unit acquires the zero reading. Ensure that the sensor is seeing clean air during this time. Calibration mode can also be entered via remote switch. This option cannot be used when the ARGV is enabled.



Figure 21: Automatic Calibration Mode

Apply the calibration gas concentration to the sensor (usually 50% LEL of the desired gas). The display will change from “AC” (Automatic Calibration) to “CP” (Calibration in Progress), indicating that the sensor is responding to the calibration gas (Figure 22).

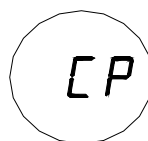

Figure 22: Calibration in Progress Mode

After one or two minutes, the display will change from “CP” to “CC” (Figure 23), indicating that the calibration is complete.

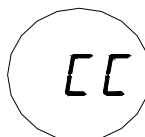

Figure 23: Calibration Complete Mode

Remove the gas and wait for the unit to return to normal operation. The display will indicate a few percent full-scale and then drop to “0”.

The unit is now calibrated and the new ZERO and SPAN values have been stored in the non-volatile memory (EEPROM).

NOTE: The sensor life figure displayed is that calculated on completion of the last calibration. To determine the current sensor life, calibrate unit and then repeat steps 1 and 2.

3.14.2 Aborting Calibration

If calibration is to be aborted, and gas has not been applied, wait ninety seconds and reapply the magnet. The unit will return to normal operation with the previous calibration values unchanged.

NOTE: Once gas has been applied, it is not possible to abort a calibration.

If the S4000CH is placed in the Calibration Mode and no gas is applied for six minutes, the unit will revert to a Fault condition. Re-applying the magnet over the GM logo will return the unit to operational mode with the previous calibration values unchanged.

3.14.3 Adjustable Calibration Level

The S4000CH provides the user with the ability to adjust the calibration level from 25% LEL to 90% LEL. The default value from the factory is 50% LEL. This allows the user to utilize gas already available at their installation, or to perform cross-calibration to a similar gas. Adjusting the Calibration Level is performed in Setup Mode.

If 50% LEL Methane is to be used to calibrate for a gas other than Methane, then the Cal ratio in the Methane column of Table 21 can be used. For example, to calibrate for Acetylene detection the Cal Ratio for using Methane is 0.8. This implies 50% Acetylene has 80% of the response of 50% LEL Methane. The Adjustable Calibration Level then needs to be increased from the default 50% to $50/0.8$ or 62%. Similarly, if 50% LEL Propane is to be used to calibrate for Acetylene then the Adjustable Calibration Level needs to be decreased from the default 50% to $50/1.1$ or 45%.

NOTE: %LEL to %Volume fraction is converted by using NFPA 325 Guide to Fire Hazard Properties of Flammable Liquids, Gases, and Volatile Solids. For example, 100% LEL CH₄ is shown in NFPA to be 5% Volume, Calibration is at 50% LEL or 2.5% Volume.

3.14.4 Remaining Sensor Life

The S4000CH Intelligent Sensor provides an estimate of remaining sensor life, in percent remaining, to provide the user with an early warning of the need for sensor replacement. The remaining sensor life is updated each time the unit is calibrated. The current remaining sensor life estimate is displayed during the zeroing portion of a calibration sequence. It can also be read via the Modbus and HART interface (Section 6.8.22).

NOTE: Remaining sensor life is an estimate of sensor degradation derived from sensor sensitivity. Because sensor sensitivity is affected by factors other than the natural sensor degradation, users must establish their own reference by resetting sensor life whenever these factors are at play. Some examples of these factors are new sensor installations, sensor replacement, change of the target gas, and changes in the access of gas to the sensor (produced by the TGA, RGC, or splash guard). If sensor life is not reset, the remaining sensor life indicator will no longer reflect the true state of the sensor.

3.14.5 Initializing the Remaining Sensor Life

The remaining sensor life estimate must be initialized each time a new hydrocarbon sensor is installed. The initialization should be done during the first calibration of a newly installed sensor. After the sensor has been on power for a minimum of one hour, enter calibration mode as described in Section 3.14.1. While the display is flashing the remaining sensor life estimate during zeroing, apply the magnet to the GM logo on the cover. The flashing number will change to “100”, indicating the sensor has 100% of remaining sensor life. Complete the calibration per Section 3.14.1.

3.15 Calibration Equipment

3.15.1 Portable Purge Calibrator

The portable purge calibrator is a compact, accurate and safe system containing a non-explosive gas concentration. The lecture bottle is filled with a standard 50% LEL mixture of gas/air. Using a known gas/air mixture reduces the likelihood of error in field calibration. A mixture of gas/nitrogen should not be used as the catalytic sensor requires oxygen for operation. The hose and cup adapter allow for quick calibrations and gas checks. Pre-mixed calibration gases at 50% LEL with balance air are available in lecture bottles at 1200 psi, 8.3 MPa maximum pressure.

Hydrogen	H ₂
Methane	CH ₄
Propane	C ₃ H ₈

Please specify the gas upon ordering. Spare bottles containing these gases may be ordered. Methane and hydrogen lecture bottles may be returned to General Monitors for refilling.

3.16 Remote Gas Calibrator

The S4000CH has optional accessories called the Remote Gas Calibrator (RGC) and the High Temperature RGC (RGC-HT). They are designed for remote or difficult to access locations. They cover the sensor and allow a controlled flow of gas to it. This allows calibration in high wind conditions and can be permanently attached to the sensor. Since it is permanently attached, it is useful for remote locations. The calibrators use a constant pressure. For calibration using the RGC or the High Temperature RGC, refer to Section 3.14.1.



Figure 24: Remote Gas Calibrator (RGC, P/N 80153-1)

3.17 ARGC Gas Control

The S4000CH has a Modbus or HART controlled output that can be used to turn the cal gas on and off remotely if the proper plumbing is provided.



Figure 25: ARGV Gas Control (P/N 80154-1)

3.18 Automatic Remote Gas Calibrator (ARGC)

The S4000CH has an optional Automatic Remote Gas Calibrator. *The ARGV is a combination of the above P/N's for local remote calibration (Figure 8). The ARGV can be remotely installed using the above P/N's and P/N 32547-1 (Remote Junction Box, Figure 9).* The ARGV is intended for remote, unmanned sites, or hard to reach gas sensors. It can be used for either Calibration Mode or Gas Check Mode. This system has a user supplied permanent tank of calibration gas. When Calibration Mode is selected, the ARGV valve turns on and off at the proper time. When Gas Check Mode is selected, the gas is turned on for 1 minute then turned off. If the gas does not arrive or leave at the appropriate time, an error will be displayed.

The sensor and the ARGV work together as a system. The ARGV will try to detect a defective valve, a bad sensor, empty gas cylinder, or stuck actuator and signal a problem by a F12 fault. When a new sensor is installed, the user should select the new sensor calibration. **In this mode, all ARGV faults are ignored.** The cause of the ARGV fault could be a dirty ARGV or poisoned sensor. If the system goes to ARGV fault the valve and sensor should be inspected. If the user calibrates again the ARGV faults will be cleared.

In poorly ventilated areas, the gas concentration at the sensor may be lower than that outside the ARGV since the meshed cylinder of the ARGV reduces airflow to the sensor. Therefore, when installing a sensor with an ARGV in a space with little air flow, it is important to adjust the warning and alarm settings to a lower level.

NOTE: The ARGV requires extra power. Connect the ARGV 24 VDC at TB2 pin 10 Refer to Table 1.

3.19 Calibration Using the ARGV

To use the ARGV the user must have previously enabled the ARGV via the display, Modbus, or HART. Once ARGV Mode is enabled it will remain enabled until disabled. To enter Calibration Mode, send the appropriate Modbus or HART command or place the magnet over the GM logo on the cover of the unit (Figure 7) and hold it there until “AC” (Figure 21) appears on the display (about ten seconds). The display will indicate “NS” (New Sensor).

This is asking if a new sensor has been installed. A new sensor command can also be sent via Modbus or HART.

NOTE: If a new sensor is installed, the “NS” option must be selected.

“NS”

If a new sensor has been installed, apply the magnet, “SEL” appears on the display. All ARGV errors will be ignored and the sensor life will be set to 100. If the sensor has been calibrated before using the ARGV, the user does not have to apply the magnet when “NS” is displayed.

“ 100”

- The display shows the remaining sensor life for about ten seconds, while the unit acquires the zero reading. If the user wants to reset the sensor life they can apply the magnet at this time. Ensure that the sensor is seeing clean air during this time. If the initial reading is greater than 5% LEL, an ARGV error will be indicated. This means the valve could be leaking.



The display will change to “AC” and the gas will be turned on. If the gas reading is less than 60% of the calibration gas, an ARGV error will be indicated. The display will change from “AC” (Automatic Calibration) to “CP” (Calibration in Progress), indicating that the sensor is responding to the calibration gas.



After one or two minutes, the display will change from “CP” to “CC” (Figure 26) indicating that the calibration is complete. Once the valve closes and the ARGV exposes the sensor to atmosphere, the system measures the rate the gas leaves the sensor. If it is slow the valve is sticking and an ARGV error is indicated.

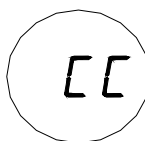

Figure 26: Calibration Complete Mode

The gas will be turned off and the unit will return to normal operation. The display will indicate a few percent full-scale and then drop to:

" 0 "

The unit is now calibrated and the new ZERO and SPAN values have been stored in the non-volatile memory (EEPROM).

When there are ARGV errors, the user should check the ARGV and the sensor. The user must recalibrate to remove the ARGV errors.

NOTE: Once a new sensor has been calibrated using the ARGV, a simple calibrate command from the display or HART is all that is required for future calibration.

4.0 Maintenance

4.1 General Maintenance



WARNING: Disconnect or inhibit external devices such as trip amplifiers, PLC's, or DCS systems before performing any maintenance.

European Union (EU) Approved Applications: The following grease compound is recommended for use: PBC Polybutylcuprysil, (or equivalent), which has BASEEFA Health & Safety Executive Component Approval No. 1051U for use as a jointing compound on flameproof electrical enclosures. This is available from General Monitors.

The neoprene rubber gasket, if found dry, should also be lubricated with Type P80 lubricant, available from General Monitors (P/N 610-010).

4.2 Storage

The S4000CH Intelligent Sensor should be stored in a clean, dry area, and within the temperature and humidity ranges quoted in the Appendix under Environmental Specifications. Insert red dust caps into any vacant cable entry holes.

5.0 Troubleshooting



CAUTION: Component level repair must be undertaken either by General Monitors' personnel, or by competent authorized service engineers. SMT PCB repair shall only be performed at a General Monitors facility. Failure to comply with this requirement will invalidate the warranty.

Be sure to inhibit or disconnect external alarm wiring before making any check, which might send the unit into alarm.

5.1 Fault Codes & Their Remedies

The S4000CH has self-diagnostics incorporated into the microprocessor's program. If a fault is detected, the output signal will drop to 0 mA, the fault relay will de-energize and a fault code will be displayed. The output signal will inform a remote display module that the S4000CH is in the Fault Mode. The display will indicate a fault code that can be viewed at the sensor site.

There are ten fault conditions that are monitored by the microprocessor, as follows:

5.1.1 F2 Failed to Complete Calibration

This fault will occur if the unit is placed in the calibration mode and no gas has been applied within six minutes, or if gas has been left on for more than six minutes.

ACTION – Remove gas, if present. Apply the magnet to the GM logo on the cover to clear the fault. Attempt to calibrate.

5.1.2 F3 Flash Checksum Error

This fault indicates that the contents of the S4000CH's program memory have changed. This usually occurs when powering the unit up after a lightning strike or large voltage transient on the power or signal lines to the unit.

ACTION - The unit must be returned to the factory or authorized service center for repair.

5.1.3 F4 Sensor Error

This fault indicates that either one of the remote sensor leads is open or shorted, or that the sensor has drifted greater than –10%. The S4000CH has an additional protection feature. If any of the sensor wires are shorted to ground, the sensor power will be turned off. After 1 minute the power will be turned back on. If the short is still present, power will quickly be turned off.

ACTION - Check the integrity of all sensor connections, and ensure that the cable from the S4000CH to the remote sensor is not damaged. If all sensor leads are connected properly, attempt to re-calibrate the unit. If calibration fails, replace the sensor and re-calibrate.

NOTE: Anytime a sensor is replaced, the unit should be disconnected from all alarms, as the unit may go upscale upon power-up.

5.1.4 F5 Unused

5.1.5 F6 Low Supply Voltage

This fault occurs if the supply voltage at the S4000CH drops below +18.5 VDC.

ACTION - Ensure that the supply voltage is at least +20 VDC at the S4000CH.

5.1.6 F7 EEPROM Error

In the event of an EEPROM error, the user must recycle the power to potentially clear the error. After power reset, the following may occur:

- 1) Unit returns to normal.
 - a. This indicates the EEPROM writing did not keep up to changing events or the write cycle is too fast.
- 2) Unit goes to F2. The user must recalibrate after 1-2 minute sensor warm up.
 - a. This means the non-critical part of the EEPROM was corrupted.
 - b. This is probably caused by an event-logging problem.
 - c. There is a possibility any of the following may be corrupted.
 - i. Event logging data
 - ii. Modbus settings
 - iii. HART settings
 - iv. Calibration information
 - v. ARGC setup
- 3) Unit returns to F7
 - a. This is a critical error. This fault occurs when an attempt to verify the setup/calibration parameters just written to the EEPROM memory fails.

ACTION - The unit must be returned to the factory or authorized service center for repair.

5.1.7 F8 Failure to Complete Setup

This fault occurs if the unit is left in setup mode for more than 6 minutes.

ACTION - Exit setup mode. Enter setup mode again if it is necessary to change any user selectable options.

5.1.8 F9 Gas Check Period Exceeded

If the S4000CH is left in the Gas Check Mode for more than six minutes or if test gas is left on the gas check mode for more than 6 minutes, this fault will occur.

ACTION - Place the magnet over the GM logo on the cover to return the unit to normal operation.

5.1.9 F10 Switch Error

This fault occurs if the “remote reset”, “remote calibrate”, or the magnetic switch is closed for more than two minutes.

NOTE: If the ARGC is enabled, the grounded calibration switch does not go to fault.

ACTION: Check the wiring on the remote reset and remote calibrate switches. Once the short circuit is cleared, the unit will return to normal operation. If the magnetic switch is

shorted, the unit must be returned to the factory or authorized service center for service.

5.1.10 F11 Internal Error

ACTION – An internal error has occurred. The unit must be returned to the factory for service. The possible errors are internal voltages are not at their proper values.

5.1.11 F12 ARGC fault

This error can only occur if the ARGC is enabled. This error implies something is wrong with the ARGC system (plunger stuck open or closed) or the sensor is poisoned.

ACTION - The sensor and ARGC should be inspected. Recalibration removes the errors. If recalibration does not remove the F12 error, the operator must inspect the ARGC and make sure the gas tank is not empty, the gas line is not leaking, and the regulator is at the proper setting. You can then apply the magnet over the display to clear the F12 error.

5.2 General Monitors' Offices

Area	Phone/Email
UNITED STATES 26776 Simpatica Circle Lake Forest, CA 92630	Phone: +1-949-581-4464. 800-446-4872 Email: info.gm@MSAsafety.com
IRELAND Ballybrit Business Park Galway Republic of Ireland, H91 H6P2	Phone: +353-91-751175
SINGAPORE No. 2 Kallang Pudding Rd. #09-16 Mactech Building Singapore 349307	Phone: +65-6-748-3488
MIDDLE EAST PO Box 54910 Dubai Airport Free Zone United Arab Emirates	Phone: +971-4294 3640

Table 8: GM Locations

Additional locations can be found on our web site, www.MSAsafety.com

6.0 Modbus Interface

6.1 Baud Rate

The Baud Rate is selectable via the Modbus Communications Interface. The selectable baud rates are 19200, 9600, 4800, or 2400 bits per second.

6.2 Data Format

The Data Format is selectable via the Modbus Communications Interface. The selectable data formats are as follows:

Data Bits	Parity	Stop Bit	Format
8	None	1	8-N-13
8	Even	1	8-E-1
8	Odd	1	8-O-1
8	None	2	8-N-2

Table 9: Data Format

6.3 Modbus Read Status Protocol (Query/Response)

6.3.1 Modbus Read Query Message

<u>Byte</u>	<u>Modbus</u>	<u>Range</u>	<u>Referenced to S4000CH</u>
1 st	Slave Address	1-247* (Decimal)	S4000CH ID (Address)
2 nd	Function Code	03	Read Holding Registers
3 rd	Starting Address Hi**	00	Not Used by S4000CH
4 th	Starting Address Lo**	00-FF (Hex)	S4000CH Commands
5 th	No. of Registers Hi	00	Not Used by S4000CH
6 th	No. of Registers Lo	01	No. of 16 Bit Registers
7 th	CRC Lo	00-FF (Hex)	CRC Lo Byte
8 th	CRC Hi	00-FF (Hex)	CRC Hi Byte

***NOTE:** Address 0 is reserved for broadcast mode and will not be supported at this time.

****NOTE:** Start Address can be a maximum of 9999 Address Locations (0000-270E).

6.3.2 Modbus Read Response Message

<u>Byte</u>	<u>Modbus</u>	<u>Range</u>	<u>Referenced to S4000CH</u>
1 st	Slave Address	1-247* (Decimal)	S4000CH ID (Address)
2 nd	Function Code	03	Read Holding Registers
3 rd	Byte Count	02	No. of Data Bytes
4 th	Data Hi	00-FF (Hex)	S4000CH Hi Byte Status Data
5 th	Data Lo	00-FF (Hex)	S4000CH Lo Byte Status Data
6 th	CRC Lo	00-FF (Hex)	CRC Lo Byte
	CRC Hi	00-FF (Hex)	CRC Hi Byte

6.4 Modbus Write Command Protocol (Query/Response)

6.4.1 Modbus Write Query Message

<u>Byte</u>	<u>Modbus</u>	<u>Range</u>	<u>Referenced to S4000CH</u>
1 st	Slave Address	1-247* (Decimal)	S4000CH ID (Address)
2 nd	Function Code	06	Preset Single Register
3 rd	Register Address Hi	00	Not Used by S4000CH
4 th	Register Address Lo	00-FF (Hex)	S4000CH Commands
5 th	Preset Data Hi	00-FF (Hex)	S4000CH Hi Byte Command Data
6 th	Preset Data Lo	00-FF (Hex)	S4000CH Lo Byte Command Data
7 th	CRC Lo	00-FF (Hex)	CRC Lo Byte
8 th	CRC Hi	00-FF (Hex)	CRC Hi Byte

***NOTE:** Address 0 is reserved for broadcast mode and will not be supported at this time.

****NOTE:** Start Address can be a maximum of 9999 Address Locations (0000-270E)

6.4.2 Modbus Write Response Message

<u>Byte</u>	<u>Modbus</u>	<u>Range</u>	<u>Referenced to S4000CH</u>
1 st	Slave Address	1-247* (Decimal)	S4000CH ID (Address)
2 nd	Function Code	06	Preset Single Register
3 rd	Register Address Hi	00	Not Used by S4000CH
4 th	Register Address Lo	00-FF (Hex)	S4000CH Commands
5 th	Preset Data Hi	00-FF (Hex)	S4000CH Hi Byte Command Data
6 th	Preset Data Lo	00-FF (Hex)	S4000CH Lo Byte Command Data
7 th	CRC Lo	00-FF (Hex)	CRC Lo Byte
8 th	CRC Hi	00-FF (Hex)	CRC Hi Byte

6.5 Function Codes Supported

- Function Code 03 (Read Holding Registers) is used to read status from the slave unit.
- Function Code 04 allows multiple registers to be read. You can use 3 or 4 for multiple reads.
- Function Code 06 (Preset Single Register) is used to write a command to the slave unit.

6.6 Exception Responses and Exception Codes

6.6.1 Exception Response

In a normal communications query and response, the master device sends a query to the S4000CH and the S4000CH receives the query without a communications error and handles the query normally within the master device's allowable timeout. The S4000CH then returns a normal response to the master. An abnormal communications query produces one of four possible events:

- If the S4000CH does not receive the query due to a communications error, then no response is returned from the S4000CH and the master device will eventually process a timeout condition for the query.
- If the S4000CH receives the query, but detects a communication error (CRC, etc.), then no response is returned from the S4000CH and the master device will eventually process a timeout condition for the query.

- If the S4000CH receives the query without a communications error, but cannot process the response to the master within the master's timeout setting, then no response is returned from the S4000CH. The master device will eventually process a timeout condition for the query. **In order to prevent this condition from occurring, the maximum response time for the S4000CH is 200 milliseconds. Therefore the master's timeout setting should be set to 200 milliseconds or greater.**
- If the S4000CH receives the query without a communications error, but cannot process it due to reading or writing to a non-existent S4000CH command register, then the S4000CH will return an exception response message informing the master of the error.

<u>Byte</u>	<u>Modbus</u>	<u>Range</u>	<u>Referenced to S4000CH</u>
1 st	Slave Address	1-247* (Decimal)	S4000CH ID (Address)
2 nd	Function Code	83 or 86 (Hex)	MSB is set with Function Code
3 rd	Exception Code	01 - 06 (Hex)	Appropriate Exception Code (See Below)
4 th	CRC Lo	00-FF (Hex)	CRC Lo Byte
5 th	CRC Hi	00-FF (Hex)	CRC Hi Byte

The exception response message (ref. No. 4 above) has two fields that differentiate it from a normal response:

6.6.2 Exception Code

Exception Code Field: In a normal response, the S4000CH returns data and status in the data field, which was requested in the query from the master. In an exception response, the S4000CH returns an exception code in the data field, which describes the S4000CH condition that caused the exception. Below is a list of exception codes that are supported by the S4000CH:

Code	Name	Description
01	Illegal Function	The function code received in the query is not an allowable action for the S4000CH.
02	Illegal Data Address	The data address received in the query is not an allowable address for the S4000CH.
03	Illegal Data Value	A value contained in the query data field is not an allowable value for the S4000CH.
04	Slave Device Failure	An unrecoverable error occurred while the S4000CH was attempting to perform the requested action.
05	Acknowledge	The S4000CH has accepted the request and is processing it, but a long duration of time will be required to do so. This response is returned to prevent a timeout error from occurring in the master.
06	Device Busy	The S4000CH is engaged in processing a long-duration program command. The master should retransmit the message later when the slave is free.

Table 10: Exception Codes

6.7 S4000CH Command Register Locations

Parameter	Function	Type	Scale	Access	Register Address	Master I/O Address
Analog	0-20mA Current Output	Value	16-Bit	R	0000	40001
Mode	Indicates and Controls Mode	Bit		R/W	0001	40002
Status/Error	Indicates Errors	Bit		R	0002	40003
Not Used	N/A				0003	40004
Unit Type	Identifies the S4000C in Decimal	Value	16-Bit	R	0004	40005
Software Rev	Indicates the Software Revision	ASCII	2-Char	R	0005	40006
Status Block	Returns Analog, Mode, Status, Error, and Sensor Life Returns Address 6,7,8	Multi	6-bytes	R	0006	40007
Analog	Analog 2	Value		R	0006	40007
Mode	Mode	Bit		R	0006	40007
Error 2	Error 2	Bit		R	0007	40008
Error 1	Error 1	Bit		R	0007	40008
Sensor Life	Sensor Life	Value		R	0008	40009
Display	Display (LED & MSD)	Bit /ASCII		R	0009	40010
Display	Display (Mid & LSD)	ASCII		R	000A	40011
Serial Number	Upper Serial Number	Value		R	000B	40012
Serial Number	Lower Serial Number	32 Bit		R	000C	40013
Alarm Settings	Read or Change settings for the high alarm	Bit	(0-15)	R/W	000D	40014
Warn Settings	Read or change settings for the low alarm	Bit	(0-15)	R/W	000E	40015
Com1 Addr	Read or change settings for the Com1 Address	Value	8-Bit	R/W	000F	40016
Com1 Baud	Read or change settings for the Com1 Baud Rate	Bit	(0-7)	R/W	0010	40017
Com1 Data Format	Read or change settings for the Com1 Data Format	Bit	(0-7)	R/W	0011	40018
Com2 Addr	Read or change settings for the Com2 Address	Value	8-Bit	R/W	0012	40019
Com2 Baud	Read or change settings for the Com2 Baud Rate	Bit	(0-7)	R/W	0013	40020
Com2 Data Format	Read or change settings for the Com2 Data Format	Bit	(0-7)	R/W	0014	40021
Cal Level	Read or change settings for the calibration level	Value	25 - 90	R/W	0015	40022
Reset Alarms	Reset latched Alarm & Warn	Bit	(0)	W	0016	40023
Sensor Life	Remaining Sensor Life	Value	25 - 100	R/W	0017	40024
	Not Used				0018	40025
HazardWatch	Indicate Calibration Success	Value	8-bit	R/W	0019	40026
ARGC	Enable/Disable ARGC	Bit	1/0	R/W	001A	40027
Enb Cal Input	Enable/Disable Cal Input	Value	1/0	R/W	001B	40028
Sol ON/OFF	Turn on/off Gas Solenoid	Value	10, 20, 30	R/W	001C	40029

Parameter	Function	Type	Scale	Access	Register Address	Master I/O Address
HART EN/DE	Enable/Disable	Bit	1/0	R/W	001D	40030
HART Test	Transmit a constant 1 or 0 signal	Value	0,1,2	R/W	001E	40031
Ch1Total Receive Errors	Total # of Receive Errors	Value	8-Bit	R	0020	40033
Ch1Bus Activity Rate %	Bus Activity Rate in % of This Addressed Node vs. Other Addressed Nodes	Decimal		R	0021	40034
Ch1Function Code Errors	Total # of Function Code Errors	Value	8-Bit	R	0022	40035
Ch1Starting Addr Errors	Total # of Starting Address Errors	Value	8-Bit	R	0023	40036
Ch1No of Register Errors	Total # of Register Errors	Value	8-Bit	R	0024	40037
RXD CRC Errors	Total # of RXD CRC Errors	Value	16-Bit	R	0025	40038
RXD CRC Errors	Total # of RXD CRC Errors Same as 38	Value	16-Bit	R	0026	40039
Ch1 Parity Errors	Total parity errors	Value	16-Bit	R	0027	40040
Ch1 Overrun Errors	Total overrun errors	Value	16-Bit	R	0028	40041
Ch1 Framing Errors	Total Framing errors	Value	16-Bit	R	0029	40042
Ch1 Software Errors	Total Software request errors	Value	16-Bit	R	002A	40043
New Sensor	New Sensor Calibration	Bit	1/0	R/W	002B	40044
Clear CH1 Errors	Clear Ch1 Hardware Errors	Bit	(0)	W	002C	40045
Clear Ch1 Errors	Clear Ch 1 Software Errors	Bit	(0)	W	002D	40046
HART Current Select	Allow the current to go from full scale to 1.25 ma while in HART mode. Normal HART current is full scale to 3.5 ma.	Value	1/0	R/W	002E	40047
Not used	Internal use only				002F	40048
Event Timer	Event Set Time Hi				0030	40049
Event Timer	Event Set Time Lo				0031	40050
	See Event CHART					
	Clear Event				005F	40096
User Info	User information 1				0060	40097
User Info	User information 2				0061	40098
User info	User information 16				006F	40112
Ch2 Total Receive Errors	Total # of Receive Errors	Value	16-Bit	R	0070	40113
Ch2 Bus Activity Rate %	Bus Activity Rate in % of This Addressed Node vs. Other Addressed Nodes	Decimal		R	0071	40114

Parameter	Function	Type	Scale	Access	Register Address	Master I/O Address
Ch2 Function Code Errors	Total # of Function Code Errors	Value	16-Bit	R	0072	40115
Ch2 Starting Addr Errors	Total # of Starting Address Errors	Value	16-Bit	R	0073	40116
Ch2 No of Register Errors	Total # of Register Errors	Value	16-Bit	R	0074	40117
Ch2	CRC errors	Value	16-Bit	R	0075	40118
Ch2	CRC errors	Value	16-Bit	R	0076	40119
Ch2 Parity Errors	Total parity errors	Value	16-Bit	R	0077	40120
Ch2 Overrun Errors	Total overrun errors	Value	16-Bit	R	0078	40121
Ch2 Framing Errors	Total Framing errors	Value	16-Bit	R	0079	40122
Ch2 Software Errors	Total Ch 2 Software request errors	Value	16-Bit	R	007A	40123
	Not used					40124
Ch2 Clear Errors	Ch2 Clear Hardware errors	Bit	0	R/W	007C	40125
Ch2 Clear Errors	Ch2 Clear Software errors	Bit	0	R/W	007D	40126
	Not used				007E	40127

6.8 S4000CH Command Register Details

6.8.1 Analog (00h)

A read returns a value, which is proportional to the 0-20 mA output current. The current is based on a 16-bit value. The scaling is 0 - 65535 decimal which corresponds to 0 - 21.7 mA.

6.8.2 Mode (01h)

A read returns the present mode of the S4000CH.

A write command changes the mode to the requested mode. A data value of 08 will start calibration mode if the unit is in the run mode. It also will go from cal check to cal mode.

A write command with the data value of 04 will put the unit in Cal Check Mode if there are no errors or alarms.

Exception: Returns an Exception Code 01 (illegal function) if an illegal write is requested.

<u>Function</u>	<u>Bit Position</u>	<u>Hex value</u>	<u>Access</u>
Calibration Complete	7 MSB	80	Read
Spanning	6	40	Read
Zero Complete, Waiting for Gas	5	20	Read
Zeroing	4	10	Read
Calibration Mode	3	08	Read/Write
Calibration Check Mode	2	04	Read/Write
Run Mode	1	02	Read
Startup Mode	0 LSB	01	Read

6.8.3 Status/Error (03h)

A read returns the alarm state and errors that are occurring at the present time, which are indicated, by bit position.

<u>Function</u>	<u>Bit Position</u>	<u>Hex value</u>	<u>Access</u>
Alarm	15 MSB	0x8000	Read
Warn	14	0x4000	Read
Fault	13	0x2000	Read
Not Used	12	0x1000	Read
Not Used	11	0x0800	Read
ARGC	10	0x0400	Read
Internal error(2.5,15 Volts)	9	0x0200	Read
Switch Error	8	0x0100	Read
Setup Error	7	0x0080	Read
Calibration Check Timeout	6	0x0040	Read
EEPROM Error	5	0x0020	Read
EPROM Error	4	0x0010	Read
Sensor Error	3	0x0008	Read
Fail to Calibrate	2	0x0004	Read
Low Supply Voltage	1	0x0002	Read
Not used	0	0x0001	

6.8.4 Unit Type (04h)

A read returns the decimal value 4004. This identifies the S4000CH.

6.8.5 Software Revision (05h)

A read returns the software revision of the S4000CH in 2 ASCII characters.

6.8.6 Status Block (06h)

A read returns a 6-byte message containing the Analog (2 bytes), Mode (1 byte), Status/Error (2 bytes), and Sensor Life (1 byte) in that order. For the format of each byte, refer to the appropriate individual commands.

NOTE: These registers can be read individually or as a group. Only when the starting address is 06 is a block returned.

6.8.7 Analog Value (06h)

A value which is proportional to the 0-20 mA output current. The current is based on a 16-bit value. The scaling is 0 - 65535 decimal which corresponds to 0 - 21.7 mA.

6.8.8 Mode & Error (07h)

See Mode (02)

Calibration Complete	8000
Spanning	4000
Zero Complete, Waiting for Gas	2000
Zeroing	1000
Calibration Mode	0800
Calibration Check Mode	0400
Run Mode	0200
Startup Mode	0100
Alarm	0080
Warn	0040
Error (any error)	0020
NA	0010
NA	0008
ARGC	0004
Internal	0002
Switch	0001

6.8.9 Error & Sensor Life (08h)

6.8.9.1 Upper 8 Bits for Sensor Errors (Hexadecimal)

Setup error	80
Cal Check error	40
EEPROM Check sum error	20
Flash Check sum	10
Sensor	08
Calibration error	04
Low supply	02
NA	01

6.8.9.2 Lower 8 Bits for Sensor Life

Sensor Life	0-100%
-------------	--------

6.8.10 Display (0x09h & 0x0Ah)

The display is also present on the Modbus. It is at address 0x09 and 0x0A. The first address (0x09) contains the LED, the decimal point location, and the Most Significant Digit (MSD). The upper word represents the LED and decimal point. They are defined as shown below. The lower word is the ASCII value for the MSD. The second address (0x0A) represents the middle digit (MID) and the Least Significant Digit (LSD) in ASCII. The upper word represents the MID and the lower word represents the LSD.

DP_LSD	0x01
DP_MID	0x02
DP_MSD	0x04
WRN_LED	0x08
ALM_LED	0x10

6.8.11 Serial Number (0Bh/0Ch)

The serial number is a 32-bit word but the value is only 23 bits long. The upper bits are always zero. This is done to keep the same serial number as the HART serial number. Address 0x0C contains the lower part of the number and address 0X0B contains the upper part.

6.8.12 Alarm Settings (0Dh)

If an alarm exists a write is not allowed and a device exception code is returned.

A read returns the present Alarm settings of the S4000CH. A write command changes the settings to the requested values. The set points are programmable in 5% FS steps.

NOTE: The maximum alarm setting for the S4000CH is 60% LEL.

A 1 in the 9th bit position means the output is Latching, a 0 means it is Non-Latching. A 1 in the 8th bit position means the output is normally Energized a 0 means it is normally De-Energized. The Alarm set point cannot be set below the Warn set point.

Factory default is 60% FS, Latching, De-Energized.

Exception: Returns an Exception Code 01 (Illegal Function) if an illegal write is requested.

<u>Byte</u>	<u>Function</u>	<u>Bit Position</u>	<u>Access</u>
High	Not Used	15 MSB	Read
	Not Used	14	Read
	Not Used	13	Read
	Not Used	12	Read
	Not Used	11	Read
	Not Used	10	Read
	Latching/Non-Latching	9	R/W
	Energized/De-Energized	8	R/W
Low	Set point	(7-0)	R/W

6.8.13 Warn Settings (0Eh)

A read returns the present Warn settings of the S4000CH. A write command changes the settings to the requested values. The set points are programmable in 5% FS steps.

NOTE: The maximum warn setting for the S4000CH is 60% LEL.

A 1 in the 9th bit position means the output is Latching, a 0 means it is Non-Latching. A 1 in the 8th bit position means the output is normally Energized, a 0 means it is normally De-Energized. The Warn set point cannot be set above the Alarm set point.

Factory default is 30% FS, non-latching, de-energized.

Exception: Returns an Exception Code 01 (Illegal Function) if an illegal write is requested.

<u>Byte</u>	<u>Function</u>	<u>Bit Position</u>	<u>Access</u>
High	Not Used	15 MSB	Read
	Not Used	14	Read
	Not Used	13	Read
	Not Used	12	Read
	Not Used	11	Read
	Not Used	10	Read
	Latching/Non-Latching	9	R/W
Low	Energized/De-Energized	8	R/W
	Set point	(7-0)	R/W

6.8.14 Com1 Address (0Fh)

A read command returns the current address for Com1. A write command changes the address to the requested value. Valid addresses are 1-247 decimal. **Factory default is 1.**

Exception: If the address is not in range, an illegal data value (03) is returned.

6.8.15 Com1 Baud Rate (10h)

A read command returns the current baud rate for Com1. A write command changes the baud rate to the requested values. Valid settings are shown in the table below. **Factory default is 19,200.**

Baud Rate	Value	Val(Hex)	Access
2400	24	18	Read/Write
4800	48	30	Read/Write
9600	96	60	Read/Write
19,200	192	C0	Read/Write

Table 11: Com1 Baud Rate

Exception: If the baud rate is not in range, an illegal data value (03) is returned.

6.8.16 Com1 Data Format (11h)

A read command returns the current data format for Com1. A write command changes the data format to the requested values. Valid settings are shown in the table below. **Default format is 8-N-1.**

Data	Parity	Stop	Format	Data(Bits 8-9)	Access
8	None	1	8-N-1	0	Read/Write
8	Even	1	8-E-1	1	Read/Write
8	Odd	1	8-O-1	2	Read/Write
8	None	2	8-N-2	3	Read/Write

Table 12: Com1 Data Format

Exception: If the data format is not in range, an illegal data value (03) is returned.

To restore all serial bus defaults:

- Hold the reset input low and turn on the power (F10 error may be displayed).
- Address factory default is 1.
- Baud rate factory default is 19,200.
- Format factory default is 8-N-1.

COM 2 is user selectable to HART or Modbus if the unit is ordered with HART. HART or Modbus is selectable via Modbus or the display. For additional information on HART, see the S4000CH HART manual.

When HART is selected there are changes to comply with the HART requirements. Since HART does not allow low current the actual current does not go below 3.5 mA. Modbus reports the analog output as if HART was not there. This allows users to use a constant program. The digital HART reports the actual current.

Function	Current Level (mA)			
	Analog Output (Standard)	Modbus	HART (Default)	HART Modified Analog Output
Start Up (SU)	4	4	4	4
Fault	0	0	3.5	1.25
HazardWatch	3.2	3.2	3.5	3.2
Cal Check	1.5	1.5	3.5	1.5
Calibrate	1.5	1.5	3.5	1.5
Gas	4-20	4-20	4-20	4-20
Over range	21.7	21.7	21.7	21.7
Negative drift (0 to -9% LEL)	2.56	2.56	3.5	2.56

Table 13: Current Chart

On HART equipped units, the user must select the HART – modified analog output in order to use analog values that are standard with gas detection equipment.

6.8.17 Com2 Address (12h)

A read command returns the current address for Com2. A write command changes the address to the requested values. Valid addresses are 1-247 decimal. **Factory default is 2.**

Exception: If the address is not in range, an illegal data value (03) is returned.

6.8.18 Com2 Baud Rate (13h)

A read command returns the current baud rate for Com2. A write command changes the baud rate to the requested values. Valid settings are shown in the table below. **Factory default is 19,200.**

Baud Rate	Value	Value(Hex)	Access
2400	24	18	Read/Write
4800	48	30	Read/Write
9600	96	60	Read/Write
19,200	192	C0	Read/Write

Table 14: Com2 Baud Rate

Exception: If the baud rate is not in range, an illegal data value (03) is returned.

6.8.19 Com2 Data Format (14h)

A read command returns the current data format for Com2. A write command changes the data format to the requested values. Valid settings are shown in the table below. **Factory default is 8-N-1.**

Data	Parity	Stop	Format	Data(Bits 9-8)	Access
8	None	1	8-N-1	0	Read/Write
8	Even	1	8-E-1	1	Read/Write
8	Odd	1	8-O-1	2	Read/Write
8	None	2	8-N-2	3	Read/Write

Table 15: Com2 Data Format

Exception: If the data format is not in range, an illegal data value (03) is returned.

To restore serial bus defaults:

- Hold the reset input low and turn on the power
- Address factory default is 2
- Baud rate factory default is 19,200.
- Format factory default is 8-N-1.

6.8.20 Calibration Level (15h)

A read returns the current settings for the calibration level. A write changes the calibration level that will be used during the next and subsequent calibrations. Valid levels are 25 to 90.

6.8.21 Reset Alarms (16h)

A write to this register with a data value of 1 will reset any latched alarms provided the current gas level is below the alarm set point.

On the S4000CH it will also reset the latching over-range function provided the gas level is below 100% LEL.

6.8.22 Sensor Life (17h)

A read returns the current estimate of remaining sensor life in percentage.

6.8.23 HazardWatch (Co – Calibration Output) (19h)

HazardWatch indicates when a successful calibration takes place. In HazardWatch mode the current goes to 3.2 mA for 5 seconds then to 4.0 mA. An aborted calibration would go straight to 4.0 mA. A read to this register will return the status of the HazardWatch option.

0x01 enables this option, 0x00 disables this option, similar to the write.

NOTE: When HART is in use, the current does not go to 3.2 mA but stays at 3.5 mA.

6.8.24 ARGC (1Ah)

The Automatic Remote Gas Calibrator is enabled or disabled by this command. A “1” enables the ARGC option and a “0” disables the option.

NOTE: When the ARGC is enabled the remote calibration input does not function.

6.8.25 PLC Remote Gas Calibration

The Enable Sol and Sol ON/OFF functions work together. Their use is to allow a PLC to turn on and off gas during a calibration or gas check. The PLC would look at the MODE register and activate or deactivate a calibration gas control valve.

6.8.25.1 Enable Sol (1Bh)

This function is a built-in safety feature. The solenoid must be enabled first before it can be activated. This disables the remote cal function and enables the solenoid.

A “0” enables the remote calibration (Normal) and disables the solenoid. A “1” disables the remote calibration and enables the solenoid.

6.8.25.2 Sol ON/OFF (1Ch)

To use this function, it must first be enabled by the Enable Sol function.

Solenoid on	10
Solenoid off	20
Return to normal	30

If the read command returns a 30, then the Sol ON/OFF function is not enabled.

NOTE: If the ARGC is enabled, the solenoid cannot be used and an exception will be returned.

6.8.26 HART Enable (1Dh)

This command enables or disables the HART. A “0” is Modbus and a “1” is HART.

6.8.27 HART Test (1Eh)

This command is used to test the HART output. It produces constant zeros or constant ones on the HART output.

Code	Results
0	Normal
1	Constant ones
2	Constant zeros

6.8.28 Abort Calibration (1Fh)

Sending a “1” will abort calibration.

6.8.29 Total Receive Errors (20h)

A read indicates the total Modbus Comm. Hardware Receive Errors that occurred in the slave device. The maximum count is 65535 and then the counter will rollover to zero and begin counting again. The total errors are an accumulation of the individual communication errors listed below.

6.8.30 Bus Activity Rate % (21h)

A read indicates the Bus Activity Rate in percent of this Slave’s addressed node versus other addressed nodes. Range of this value is in hex (0-64), which translates to decimal (0-100%).

6.8.31 Function Code Errors (22h)

A read indicates the number of Function Code Errors that occurred in the slave device. The maximum count is 65535 and then the counter will rollover to zero and begin counting again.

6.8.32 Starting Address Errors (23h)

The counter is incremented for each address that does not equal the device address. A read indicates the number of Starting Address Errors that occurred in the slave device. The maximum count is 65535 and then the counter will rollover to zero and begin counting again.

6.8.33 Number of Register Errors (24h)

A read indicates the Number of Register Errors that occurred in the slave device. The maximum count is 65535 and then the counter will rollover to zero and begin counting again.

6.8.34 RXD CRC Errors Hi (25h)

A read indicates the number of RXD CRC Errors that occurred in the slave device. The maximum count is 65535 and then the counter will rollover to zero and begin counting again.

6.8.35 RXD CRC Errors Lo (Same as Hi) (26h)

NOTE: Hi and Lo CRC errors are now reported in the same word. A read from either Hi or Lo will return the same count.

6.8.36 Parity Errors (27h)

A read indicates the number of hardware UART Parity Errors that occurred in the slave device. The maximum count is 65535 and then the counter will rollover to zero and begin counting again.

6.8.37 Overrun errors (28h)

A read indicates the number of hardware UART Overrun Errors that occurred in the slave device. The maximum count is 65535 and then the counter will rollover to zero and begin counting again.

6.8.38 Framing Errors (29h)

A read indicates the number of hardware UART Framing Errors that occurred in the slave device. The maximum count is 65535 and then the counter will rollover to zero and begin counting again.

6.8.39 Total Software CH1 Errors (2Ah)

A read indicates the number of address or data errors that occurred in the slave device. The maximum count is 65535 and then the counter will rollover to zero and begin counting again.

6.8.40 New Sensor Calibration (2Bh)

The new sensor calibration command performs a calibration only when the ARGV is enabled, otherwise it returns an exception. It also tells the ARGV function this is a new sensor and the data will be saved. Stored data may later be used to verify proper calibration.

NOTE: All new installations should perform this calibration.

6.8.41 Clear Hardware Errors (2Ch)

For clearing parity, framing and overrun errors.

6.8.42 Clear Communication Errors (2Dh)

6.8.42.1 Event Logging

Faults

- Whenever the fault word changes the time will be recorded.
- The time of the fault will be saved.
- The quantity of faults will be saved in a counter.
- When the fault is removed, it is not saved and the counter is not incremented.
- A fault event is logged for every 30 seconds recorded.
- There are a total of 10 event time stamps stored.

Warning

The time the gas level reaches the Warning level is recorded. Each time this happens a counter is incremented. The end of the event is when the gas goes below 5%. The counter is also saved. There are a total of 10 event time stamps stored.

Alarm

The time the gas level reaches the Alarm level is recorded. Each time this happens a counter is incremented. The end of the event is when the gas goes below 5%. The counter is also saved. There are a total of 10 event time stamps stored.

Calibration

The time a successful zero and calibration occurs is saved in the event log. A counter is incremented for each successful calibration. If the unit fails Zero or Cal the event is not recorded. If the calibration is aborted the event is also not recorded. Note the Zero and Calibration are one operation in the S4000CH. There are a total of 10 event time stamps stored.

Maintenance

The time a Check Calibration occurs is saved in the maintenance event log. Each successful calibration increments the maintenance counter. There are a total of 10 event time stamps stored.

Setting Clock

Please see table below.

Event Logging Registry Table

<u>Address (hex)</u>	<u>Parameter</u>	<u>Function</u>	<u>Data Type</u>	<u>Data range</u>	<u>Access</u>
30	Seconds Time Hi	Seconds Time Hi	Numeric value	0 – 65535	Timer Sec
31	Seconds Time Low	Seconds Time	Numeric value	0 – 65535	Timer sec
32	Real Time Clock Year, Month	Read/Set year and month of RTC	2 Numeric Values	0-99 year, 1 – 12 month	Timer Struct
33	Real Time Clock Day, Hour	Read/Set day and hour of RTC	2 Numeric Values	1 – 31 day, 0 – 23 hour	
34	Real Time Clock Minute, Second	Read/Set minutes and seconds of RTC	2 Numeric Values	0 – 59 minute, 0 – 59 second	Timer Struct
35	PowerCycleFlag	Read Power Cycle Flag.	Numeric Value	1 – Time Not Reset; 0 – Time Was Reset	Flag
36	Event Index	Event index of Logged Event	Numeric value	0 - 9	Index
37	Warn Seconds Time Hi	Seconds Time Hi for warning event log entries	Numeric value	0 – 65535	Warn
38	Seconds Time Low	Seconds Time Low for warning event log entries	Numeric value	0 – 65535	Warn
39	Structure time Hi	Hi byte – year, low byte – month for warning event log entries	Numeric value	0 – 65535	Warn

<u>Address (hex)</u>	<u>Parameter</u>	<u>Function</u>	<u>Data Type</u>	<u>Data range</u>	<u>Access</u>
3A	Structure time Mid	Hi byte – day, low byte – hour warning event log entries	Numeric value	0 – 65535	Warn
3B	Structure time Low	Hi byte – min, low byte – sec for warning event log entries	Numeric value	0 – 65535	Warn
3C	Reserved	Reserved	Numeric value	0	
3D	Reserved	Reserved	Numeric value	0	
3E	Warn Event Count	Warning Event Count	Numeric value	0 – 65535	Warn
3F	Alarm Seconds Time Hi	Seconds Time Hi for alarm event log entries	Numeric value	0 – 65535	Alarm
40	Seconds Time Low	Seconds Time Low for alarm event log entries	Numeric value	0 – 65535	Alarm
41	Structure time Hi	Hi byte – year, low byte – month for alarm event log entries	Numeric value	0 – 65535	Alarm
42	Structure time Mid	Hi byte – day, low byte – hour alarm event log entries	Numeric value	0 – 65535	Alarm
43	Structure time Low	Hi byte – min, low byte – sec for alarm event log entries	Numeric value	0 – 65535	Alarm
44	Reserved	Reserved	Numeric value	0	
45	Reserved	Reserved	Numeric value	0	
46	Alarm Event Count	Alarm Event Count	Numeric value	0 – 65535	Alarm
47	Fault Seconds time Hi	Seconds Time Hi for fault event log entries	Numeric value	0 – 65535	Fault
48	Seconds time Low	Seconds Time Low for fault event log entries	Numeric value	0 – 65535	Fault
49	Structure time Hi	Hi byte – year, low byte – month for fault event log entries	Numeric value	0 – 65535	Fault

<u>Address (hex)</u>	<u>Parameter</u>	<u>Function</u>	<u>Data Type</u>	<u>Data range</u>	<u>Access</u>
4A	Structure time Mid	Hi byte – day, low byte – hour alarm event log entries	Numeric value	0 – 65535	Fault
4B	Structure time Low	Hi byte – min, low byte – sec for fault event log entries	Numeric value	0 – 65535	Fault
4C	Fault code	Fault code. Same code as register 2	Numeric value	0 – 65535	Fault
4D	Reserved	Reserved	Numeric value	0	
4E	Fault Event Count	Fault Event Count	Numeric value	0 – 65535	Fault
4F	Maintenance Seconds time Hi	Seconds Time Hi for event log entries	Numeric value	0 – 65535	Maintenance
50	Seconds time Low	Seconds Time Low for event log entries	Numeric value	0 – 65535	Maintenance
51	Structure time Hi	Hi byte – year, low byte – month for event log entries	Numeric value	0 – 65535	Maintenance
52	Structure time Mid	Hi byte – day, low byte – hour event log entries	Numeric value	0 – 65535	Maintenance
53	Structure time Low	Hi byte – min, low byte – sec for event log entries	Numeric value	0 – 65535	Maintenance
54	Maintenance code	Cal check	Numeric value	0	Maintenance
55	Reserved	Reserved	Numeric value	0	
56	Maintenance Count	Maintenance Count	Numeric value	0 – 65535	Maintenance
57	Calibrate Seconds Time Hi	Seconds Time Hi for event log entries	Numeric value	0 – 65535	Calibrate
58	Seconds Time Low	Seconds Time Low for event log entries	Numeric value	0 – 65535	Calibrate
59	Structure time Hi	Hi byte – year, low byte – month for event log entries	Numeric value	0 – 65535	Calibrate
5A	Structure time Mid	Hi byte – day, low byte – hour event log entries	Numeric value	0 – 65535	Calibrate

<u>Address (hex)</u>	<u>Parameter</u>	<u>Function</u>	<u>Data Type</u>	<u>Data range</u>	<u>Access</u>
5B	Structure time Low	Hi byte – min, low byte – sec for event log entries	Numeric value	0 – 65535	Calibrate
5C	Calibrate code	Cal	Numeric value	0	Calibrate
5D	Reserved	Reserved	Numeric value	0	
5E	Calibrate Count	Calibrate Count	Numeric value	0 – 65535	Calibrate
5F	Reset Event Counters	Reset Event Counters	Numeric value	1	Reset

6.8.43 User Information (60h to 6Fh)

There is a section in memory that allows the user to store information. This is useful if the physical location or other user identification is required. The only restriction on the information is it must be Modbus compatible. Only one word can be written per command. There are a total of 16 words for the user.

6.8.44 Total Receive Errors (70h)

A read indicates the total Modbus Comm. Hardware Receive Errors that occurred in the slave device. The maximum count is 65535 and then the counter will rollover to zero and begin counting again. The total errors are an accumulation of the individual communication errors listed below.

6.8.45 Bus Activity Rate % (71h)

A read indicates the Bus Activity Rate in percent of this Slave's addressed node versus other addressed nodes. Range of this value is in hex (0-64), which translates to decimal (0-100%).

6.8.46 Function Code Errors (72h)

A read indicates the number of Function Code Errors that occurred in the slave device. The maximum count is 65535 and then the counter will rollover to zero and begin counting again.

6.8.47 Starting Address Errors (73h)

The counter is incremented for each address that does not equal the device address. A read indicates the number of Starting Address Errors that occurred in the slave device. The maximum count is 65535 and then the counter will rollover to zero and begin counting again.

6.8.48 Number of Register Errors (74h)

A read indicates the Number of Register Errors that occurred in the slave device. The maximum count is 65535 and then the counter will rollover to zero and begin counting again.

6.8.49 RXD CRC Errors Hi (75h)

A read indicates the number of RXD CRC Errors that occurred in the slave device. The maximum count is 65535 and then the counter will rollover to zero and begin counting again.

6.8.50 RXD CRC Errors Lo (Same as Hi) (76h)

NOTE: Hi and Lo CRC errors are now reported in the same word. A read from either Hi or Lo will return the same count.

6.8.51 Parity Errors (77h)

A read indicates the number of Hardware UART Parity Errors that occurred in the slave device. The maximum count is 65535 and then the counter will rollover to zero and begin counting again.

6.8.52 Overrun Errors (78h)

A read indicates the number of Hardware UART Overrun Errors that occurred in the slave device. The maximum count is 65535 and then the counter will rollover to zero and begin counting again.

6.8.53 Framing Errors (79h)

A read indicates the number of Hardware UART Framing Errors that occurred in the slave device. The maximum count is 65535 and then the counter will rollover to zero and begin counting again.

6.8.54 Total software CH1 errors (7Ah)

A read indicates the number of Address or Data Errors that occurred in the slave device. The maximum count is 65535 and then the counter will rollover to zero and begin counting again.

7.0 Appendix

7.1 Warranty

General Monitors warrants the Model S4000CH to be free from defects in workmanship or material under normal use and service within two years from the date of shipment.

General Monitors will repair or replace without charge any such equipment found to be defective during the warranty period. Full determination of the nature of, and responsibility for, defective or damaged equipment will be made by General Monitors' personnel.

Defective or damaged equipment must be shipped to the General Monitors plant, or representative from which the original shipment was made. In all cases, this warranty is limited to the cost of the equipment supplied by General Monitors. The customer will assume all liability for the misuse of this equipment by its employees, or other personnel.

All warranties are contingent upon proper use in the application for which the product was intended and do not cover products which have been modified or repaired without General Monitors' approval or which have been subjected to neglect, accident, improper installation or application, or on which the original identification marks have been removed or altered.

Except for the express warranty stated above, General Monitors disclaims all warranties with regard to the products sold, including all implied warranties of merchantability and fitness, and the express warranties stated herein are in lieu of all obligations or liabilities on the part of General Monitors for damages including, but not limited to, consequential damages arising out of, or in connection with, the performance of the product.

7.2 Principle of Operation

Many gases and vapors are combustible. General Monitors uses a low temperature catalytic bead to detect the presence of combustible gases and vapors. The catalytic bead converts the combustible materials to heat. A change in heat is then converted to a change in resistance, which can be measured.

Taking a matched pair of catalytic beads and coating one so that it does not respond to the presence of combustible gases can compare the change in resistance between the two beads. The bead that is coated is called the reference bead and the other is called the active bead. Because the beads are a matched pair, they will respond equally to changes in ambient temperature, humidity, and pressure. This makes the sensor virtually immune to changing environmental conditions.

By connecting one end of each catalytic bead together, a series circuit is formed. This circuit is supplied with a constant current. The voltage drop across each of the beads will be identical in the absence of combustible gases. As combustible material is converted to heat, the resistance of the active bead increases, causing the voltage drop across each bead to be different. This difference is proportional to the amount of combustible gas that is present.

The voltage from the sensor is amplified and fed to an Analog to Digital (A/D) converter and then made available to the microprocessor. The baseline and the gain for the amplifier are set using digital potentiometers. They are adjusted by the microprocessor during calibration.

7.3 Specifications

7.3.1 System Specifications

Sensor Type:	Continuous diffusion, low temperature catalytic bead
Sensor Life:	3 to 5 years typical
Accuracy:	±3% LEL up to 50% LEL ±5% LEL ≥ 51% LEL
Zero Drift:	Less than 5% of full scale per year
Response Time:	T50<10 sec. T90<30 sec. with 100% LEL methane applied
Measuring Ranges:	0-100% LEL
Modes:	Calibration, gas check, setup
Approvals	CSA/FM: Class I, Division 1, Groups B, C, D, T6 (T _{amb} =-40°C to +75°C)
Classification:	CSA Zones: Ex db IIB + H ₂ T4 Gb (T _{amb} = -40°C to +70°C) ATEX/IECEX: II 2 GD Ex db IIB+H ₂ T4 Gb, Ex tb IIIC T135°C Db (T _{amb} =-40°C to +70°C) EN 60079-29-1
Pressure Limits:	Up to 3 atmospheres, sensor requires 15 minutes from start up to stabilize
Warranty:	Two years

7.3.2 Mechanical Specifications

Length:	6.4 in (161 mm)
Height:	3.4 in (86 mm)
Width:	4.1 in (104 mm)
Weight:	5.5 lbs (2.5 kg) AL, 14.0 lbs (6.4 kg) SS
Mounting Holes:	5.0 inches (127mm) center to center
Housing:	Aluminum alloy (6061-T6 cover, A356-T6 base) or 316 SST

7.3.3 Electrical Specifications

Input Voltage:	24 VDC nominal, 20 to 36 VDC 250 mA max.
Average Current (No ARGC) 24 V:	200 mA including sensor, all relays on
30 volts:	175 mA including sensor, all relays on
20 volts:	228 mA including sensor, all relays on
Current ARGC only:	.035 mA in addition to S4000CH current
Power ARGC only:	.85 Watts This is additional power required by the ARGC
Relay Ratings:	8 A @ 250 VAC/8 A @ 30 VDC resistive max. (3x) SPDT - Warning, Alarm & Fault 0-20 mA (650 Ohms max. load) All readings ±0.05 mA

Analog Signal:

Mode	HART not enabled	HART	HART modified AO
Malfunction	0 mA	3.5 mA	1.25mA
Calibration	1.5 mA	3.5 mA	1.5 mA
Gas Check	1.5 mA	3.5 mA	1.5 mA
Setup	1.5 mA	3.5 mA	1.5 mA
Startup	3.5 mA	3.5 mA	3.5 mA
Zero reading	4.05 mA	4.05 mA	4.05 mA
0-100% LEL	4-20 mA	4.0 – 20 mA	4.0 – 20 mA
Over-range	20-22 mA	20 – 21.7 mA	20 – 21.7 mA

Status Indicators:	Three-digit digital display with gas concentration, Warn and Alarm
---------------------------	--

	LED's, calibration prompts, fault codes, and setup options.
RS-485 Output (Optional):	Dual Redundant Modbus RTU, suitable for linking up to 128 units or up to 247 units with repeaters.
HART (Optional):	Fully HART Compliant. User selectable between HART and Modbus. HART current source Rx = 100KΩ Cx = 2nF.
Baud Rate:	2400, 4800, 9600, or 19200 BPS
Faults Monitored:	Calibration error, sensor error, low DC supply, EEPROM, EPROM, setup error, gas check time exceeded, switch error, ARGV, and internal problem.
EMC Protection:	Complies with EN 50270, EN 61000-6-4

7.3.4 Cable Requirements

Cable Requirements: (w/out ARGV & with relays)

3-wire shielded cable. Max. Distance between S4000CH and power source @ 24 VDC nominal.

AWG	Ohms/1K	FEET	METERS
12*	1.588	4143	1263
14	2.525	2606	794
16	4.016	1638	499
18	6.385	1030	314
20	10.15	648	198

Table 16: 24 VDC Cable Lengths with Relays

** Screw terminals only*

Cable Requirements (w/out ARGV & w/out Relays)

3-wire shielded cable. Max. Distance between S4000CH and power source @ 24 VDC nominal.

AWG	Ohms/1K	FEET	METERS
12*	1.588	4541	1384
14	2.525	2856	871
16	4.016	1796	547
18	6.385	1129	344
20	10.15	710	217

Table 17: 24 VDC Cable Lengths w/o Relays

** Screw terminals only*

Cable Requirements: (with ARGV & with Relays)

3-wire shielded cable. Max. Distance between S4000CH and power source @ 24 VDC nominal.

AWG	Ohms/1K	FEET	METERS
12*	1.588	3661	1116
14	2.525	2303	702
16	4.016	1448	441
18	6.385	911	278
20	10.15	573	175

Table 18: ARGV Cable Lengths

** Screw terminals only*

Max. distance for analog output (650 Ohms max):

AWG	FEET	METERS
14	9000	2740
16	5200	1585
18	3800	1160
20	2400	730

Table 19: Analog Output Cable Lengths

NOTE: The analog circuit can tolerate a negative output up to -5 volts.

7.3.5 Remote Sensor Cable Lengths

The remote sensor can have up to 1.5 Ohms in each wire. The wires must be of equal length and size.

NOTE: The power wiring length is reduced by 10% due to loss in sensor wiring.

AWG	Ohm/1000 ft	Feet	Meters
12	1.588	1007	307
14	2.525	633	193
16	4.016	398	121
18	6.385	250	76
20	10.15	157	48

Table 20: Sensor Cable Lengths

European Union (EU) Approved Applications: PSU noise and ripple voltage 1.0 Vpp max. The customer supplied PSU must comply with IEC 61010-1, limiting current to 8 A under fault conditions, in order to comply with CE Marking requirements.

7.3.6 Environmental Specifications

Operating Temperature Range	CSA	FM	ATEX/IECEX
Electronics	Division Classification -40°F to +167°F (-40°C to +75°C) -40°F to +392°F (-40°C to +200°C)* Zone Classification -40°F to +158°F (-40°C to +70°C)	-40°F to +167°F (-40°C to +75°C)	-40°F to +158°F (-40°C to +70°C)
Storage Temperature Range	-58°F to +185°F (-50°C to +85°C)		
Operating Humidity Range	0% to 95% RH, non-condensing		
Atmosphere	Will not operate in <5% Oxygen. Oxygen enriched reading may be slightly higher.		

*With remote junction box 10252-3 and 11159-2 sensor.

7.4 Approvals

CE Marking, CSA (CSA 01.1158726), FM, ATEX (SIRA 03ATEX1295X), IECEx (SIR 12.0066X), EAC and PESO certified. DNV-GL Type Approved and certified to the Marine Equipment Directive. Complies with ANSI/ISA-12.13.01-2000, CSA 22.2 No. 152, CSA 22.2 No. 60079-29-1 and EN 60079-29-1 performance requirements. SIL 2/3 suitable (*use in typical environments has a lower safety rating than in clean environments*). HART Registered.

HART:

- Approved by the HART Communication Foundation.
- Compatible with Emerson 375 Field Communicator.
- Listed in Emerson Process Management's Aware device list

7.5 Sensitivities to Other Gases

The S4000CH responds to the following list of hydrocarbons up to C10. See Section 3.14.3 on how to use a Cal Ratio with the Adjustable Calibration Level.

Gases	%LEL	M.W.	Density	Injection volumes		Cal Ratio	
				50%lel/3L	50%lel/5L	Methane	Propane
Acetylene	2.5	26.0	***	37.5 ml	62.5 ml	0.8	1.1
Ammonia	15.0	17.0	***	225.0 ml	375.0 ml	1.3	1.7
1,3- Butadiene	2.0	54.1	***	30.0 ml	50.0 ml	0.8	1.1
Butane	1.9	58.1	***	28.5 ml	47.5 ml	0.7	0.9
iso-Butane	1.8	58.1	***	27.0 ml	45.0 ml	0.6	0.8
1-Butene (Butylene)	1.6	56.1	***	24.0 ml	40.0 ml	0.7	0.9
cis-Butene-2	1.7	56.1	***	25.5 ml	42.5 ml	0.7	0.9
trans-Butene-2	1.8	56.1	***	27.0 ml	45.0 ml	0.7	0.9
iso-Butylene	1.8	56.1	***	27.0 ml	45.0 ml	0.7	0.9
Carbon Monoxide	12.5	28.0	***	187.5 ml	312.5 ml	0.9	1.2
Dimethylamine	2.8	45.1	***	42.0 ml	70.0 ml	0.6	0.8
Ethane	3.0	30.1	***	45.0 ml	75.0 ml	0.8	1.1
Ethylene Oxide	3.0	44.0	***	45.0 ml	75.0 ml	1.0	1.3
Ethylene (Ethene)	2.7	28.1	***	40.5 ml	67.5 ml	0.8	1.1
Hydrogen	4.0	2.0	***	60.0 ml	100.0 ml	0.8	1.1
Methane	5.0	16.0	***	75.0 ml	125.0 ml	1.0	1.3
Propane	2.1	44.1	***	31.5 ml	52.5 ml	0.8	1.0
Propylene (Propene)	2.0	42.1	***	30.0 ml	50.0 ml	0.8	1.0
Trimethylamine	2.0	59.1	***	30.0 ml	50.0 ml	0.6	0.8
Vinyl Chloride (Chloroethylene)	3.6	62.5	***	54.0 ml	90.0 ml	0.7	0.9
Acetaldehyde	4.0	44.1	0.8	136 µl	228 µl	0.7	0.9
Gases	%LEL	M.W.	Density	Injection volumes		Cal Ratio	
				50%lel/3L	50%lel/5L	Methane	Propane
Acetic Acid	4.0	60.1	1.0	140 µl	234 µl	0.5	0.7
Acetone	2.5	58.1	0.8	112 µl	187 µl	0.6	0.8
Acetic Acid	4.0	60.1	1.0	140 µl	234 µl	0.5	0.7
Acetone	2.5	58.1	0.8	112 µl	187 µl	0.6	0.8
Acetonitrile	3.0	41.1	0.8	96 µl	160 µl	0.7	0.9
Acrylonitrile	3.0	53.1	0.8	120 µl	201 µl	0.8	1.1
Amyl Acetate	1.1	130.2	0.9	100 µl	167 µl	0.3	0.4
Benzene	1.2	78.1	0.9	65 µl	109 µl	0.6	0.8
Butyl Acetate	1.7	116.2	0.9	137 µl	228 µl	0.5	0.7
Butyl Alcohol (1- Butanol)	1.4	74.1	0.8	78 µl	131 µl	0.4	0.5

sec-Butyl Alcohol (2-Butanol)	1.7	74.1	0.8	95 µl	159 µl	0.4	0.5
tert- Butyl Alcohol	2.4	74.1	0.8	138 µl	231 µl	0.7	1.0
Butyraldehyde	1.9	72.1	0.8	102 µl	171 µl	0.5	0.7
Cyclohexane	1.3	84.2	0.8	86 µl	143 µl	0.6	0.8
Diethyl Ketone (3-Pentanone)	1.6	86.1	0.8	103 µl	173 µl	0.5	0.7
p-Dioxane	2.0	88.1	1.0	104 µl	174 µl	0.5	0.6
Ethyl Acetate	2.0	88.1	0.9	119 µl	199 µl	0.6	0.8
Ethyl Amine	3.5	45.1	0.7	140 µl	234 µl	0.5	0.6
Ethyl Benzene	0.8	106.2	0.9	60 µl	100 µl	0.5	0.6
Ethyl Ether	1.9	72.2	0.7	120 µl	200 µl	0.7	0.9
Gasoline	1.4	100.2	0.8	107 µl	179 µl	0.5	0.7
Heptane	1.1	100.2	0.7	94 µl	157 µl	0.5	0.6
Hexane	1.1	86.2	0.7	86 µl	144 µl	0.5	0.6
Isopentane (2-Methylbutane)	1.4	72.2	0.6	99 µl	166 µl	0.6	0.8
Isoprene (2-Methyl-1, 3-Butadiene)	1.5	68.1	0.7	89 µl	149 µl	0.6	0.8
JP-4 (Jet fuel)	1.3	184.4	0.8	183 µl	306 µl	0.3	0.4
Methanol (Methyl Alcohol)	6.0	32.0	0.8	148 µl	248 µl	0.8	1.1
Methyl Ethyl Ketone (2-Butanone)	1.4	72.1	0.8	76 µl	128 µl	0.6	0.8
Methyl Methacrylate	1.70	100.1	0.9	111 µl	186 µl	0.6	0.7
Methyl-t-Butyl Ether(MTBE)	1.5	88.2	0.7	109 µl	182 µl	0.6	0.8
Naphtha (Petroleum Ether)	1.1	86.2	0.6	96 µl	161 µl	0.6	0.8
Octane	1.0	114.2	0.7	99 µl	166 µl	0.5	0.6
Pentane	1.5	72.2	0.6	105 µl	176 µl	0.6	0.8
2-Propanol (Isopropyl Alcohol)	2.0	60.1	0.8	93 µl	156 µl	0.6	0.8
Propanol (Propyl Alcohol)	2.2	60.1	0.8	100 µl	168 µl	0.6	0.7
Propylacetate	1.7	102.1	1.0	106 µl	177 µl	0.5	0.7
Propylamine	2.0	59.1	0.7	103 µl	172 µl	0.6	0.8
Propylene Oxide	2.3	58.1	0.8	98 µl	164 µl	0.7	1.0
Styrene (Vinyl Benzene)	0.9	104.2	0.9	63 µl	105 µl	0.5	0.6
Tetrahydrofuran	2.0	72.1	0.9	99 µl	166 µl	0.7	0.9
1,1,1-Toluene (Methylbenzene, Toluol)	1.1	101.2	0.9	78 µl	131 µl	0.5	0.7
Triethylamine	1.2	101.2	0.7	102 µl	171 µl	0.6	0.8
o-Xylene	0.9	106.2	0.9	68 µl	113 µl	0.4	0.5
p- Xylene	1.1	106.2	0.9	83 µl	139 µl	0.4	0.5
m- Xylene	1.1	106.2	0.9	83 µl	139 µl	0.4	0.5
Xylenes	1.1	106.2	0.9	83 µl	139 µl	0.4	0.5

Table 21: Chemical List

7.6 Spare Parts and Accessories

To order spare parts and/or accessories, please contact the nearest General Monitors representative, or General Monitors directly, and give the following information:

- Part Number of Spare Part or Accessory
- Description of Spare Part or Accessory
- Quantity of Spare Part or Accessory

7.6.1 Sensors

10001-1	Standard Industrial Hydrocarbon
10001-1R	Poison Resistant
10014-1	Standard Industrial Hydrocarbon High Temp
10015-1	Standard Industrial Hydrocarbon High Temp Export Version
10022-1	Standard Industrial Hydrocarbon High Temp PTB
10058-1	Standard Industrial Stainless Steel, Hydrocarbon
10058-1R	Standard Industrial Stainless Steel, Hydrocarbon, Poison Resistant
10164-1	Sensor Assembly, Hydrogen Specific
11159-1, 1L	General Purpose, SST, Sintered Steel Arrestor
11159-2, 2L	General Purpose, SST, High Temp, Sintered Steel Arrestor
10102-1	Simulator Sensor

7.6.2 Sensor Housing

10252-1	Sensor Housing
10252-3	Sensor Housing HT

7.6.3 Sensor Accessories

10041-1	Duct Mounting Plate
50061-1	Purafil Insert Assembly

7.6.4 Calibration Equipment

10543-1	3-Liter Calibration Chamber with 250µL Syringe
928-700	Dish for the 3- Liter Chamber
928-715	250µL syringe
1400276-1	Portable Purge Calibrator, Methane (balance air) @ 50% LEL
1400276-5	Portable Purge Calibrator, Hydrogen (balance air) @ 50% LEL
1400276-19	Portable Purge Calibrator, Butadiene (balance air) @ 50% LEL
1400276-6	Portable Purge Calibrator, Propane (balance air) @ 50% LEL
1400275-1A	Replacement Cylinder, Methane (balance air) @ 50% LEL
1400276-5A	Replacement Cylinder, Hydrogen (balance air) @ 50% LEL
1400275-19A	Replacement Cylinder, Butadiene (balance air) @ 50% LEL
1400275-6A	Replacement Cylinder, Propane (balance air) @ 50% LEL
80153-1	Remote Gas Calibrator (RGC)
80135-1	High Temp Remote Gas Calibrator (RGC-HT)
80154-1	Automatic Gas Calibrator (ARGC) - RGC w/Solenoid Valve
80155-1	Remote ARGC – (ARGC w/Junction Box P/N 32547-1)
32547-1	Junction Box with Connecting Board

Cylinder refills are available for Methane and Hydrogen only. Replacement cylinders must be ordered for the other gases.

922-009	Pressure Regulator Gauge
1400152-1	Small Calibration Cup
1400154	Large Calibration Cup
925-026	Tubing

7.6.5 S4000CH Replacement Parts

Check Factory for options:

32461-1,2,3,4	Control Board Electronics
32451-1,2	Output Board Electronics
32441-1	Display Board Electronics
32424-1	Enclosure Cover Assembly with Window
31195-2	Enclosure Base Assembly
30060-1	Calibration Magnet
925-5007	Cover Assy. O-Ring

7.6.6 Recommended Spare Parts for One (1) Year

30060-1	Extra Calibration Magnet (Qty. 1)
---------	-----------------------------------

7.7 FM Approval

Factory Mutual Research Corporation
1151 Boston-Providence Turnpike
Norwood, Massachusetts 02062

Approval of the transmitter does not include, or imply, approval of apparatus to which the transmitter may be connected and which processes the electronic signal for the eventual end use. In order to maintain FMRC approved system, the control instrument, to which the subject instrument is connected, must be FMRC approved.

The following sensors have been FMRC approved for use with the Model S4000CH:

- 10001-1 Aluminum Body General Purpose Combustible Gas Sensor
- 10058-1 Stainless Steel Body General Purpose Combustible Gas Sensor

The following apparatus have been FMRC approved (although they have not been verified as part of a Model S4000CH system):

- Model DC110 Eight Channel Readout/Relay Display Module

Factory Mutual Research Corporation has tested the Model S4000CH according to the criteria listed under the FMRC Approval Standards for Combustible Gas Detectors, Class Numbers 6310 & 6320.

FMRC has tested the Model S4000CH using the specifications listed in Section 7.3. This permits an operating temperature of -40°F to +167°F (-40°C to +75°C), a general purpose sensor (10001-1 or 10058-1) attached to the housing (i.e. not remote), calibration performed with a General Monitors Portable Purge Calibrator using 50% LEL gas (balance air of Methane, Hydrogen, Butadiene, Butane, Ethane or Propane) and the procedure listed in Section 3.14. Conduit seals must be installed within 18 inches of the enclosure. If the non-latching relay option has been selected from the relay options, the user must provide alternate means of latching the relay output.



ADDENDUM
Product Disposal Considerations

This product may contain hazardous and/or toxic substances.

EU Member states shall dispose according to WEEE regulations. For further General Monitors' product WEEE disposal information please visit: www.MSAafety.com

All other countries or states: please dispose of in accordance with existing federal, state and local environmental control regulations.