



PrimaX[®] Gas Monitor

Instruction Manual



WARNING

THIS MANUAL MUST BE CAREFULLY READ BY ALL INDIVIDUALS WHO HAVE OR WILL HAVE THE RESPONSIBILITY FOR USING OR SERVICING THE PRODUCT. Like any piece of complex equipment, this instrument will perform as designed only if it is used and serviced in accordance with the manufacturer's instructions. OTHERWISE, IT COULD FAIL TO PERFORM AS DESIGNED AND PERSONS WHO RELY ON THIS PRODUCT FOR THEIR SAFETY COULD SUSTAIN SEVERE PERSONAL INJURY OR DEATH.

The warranties made by Mine Safety Appliances Company with respect to the product are voided if the product is not used and serviced in accordance with the instructions in this manual. Please protect yourself and others by following them. We encourage our customers to write or call regarding this equipment prior to use or for any additional information relative to use or repairs.

IN the U.S., to contact your nearest stocking location, dial toll-free 1-800-MSA-INST. To contact MSA International, dial 724-776-8626. For repair inquiries, dial 1-800-MSA-INST.

© MINE SAFETY APPLIANCES COMPANY 2012 - All Rights Reserved

This manual is available on the internet at www.msaSafety.com
Manufactured by

MSA NORTH AMERICA

1000 Cranberry Woods Drive, Cranberry Township, PA, 16066

MSA Permanent Instrument Warranty

1. **Warranty-** Seller warrants that this product will be free from mechanical defect or faulty workmanship for the following period:

- Oxygen, Toxic, or Catalytic Combustible Sensor: eighteen (18) months from date of shipment or one 1 year from installation, whichever occurs first.
- Gas Monitor: eighteen (18) months from date of shipment or one 1 year from installation, whichever occurs first.

provided it is maintained and used in accordance with Seller's instructions and/or recommendations. This warranty does not apply to expendable or consumable parts whose normal life expectancy is less than one 1 year such as, but not limited to, non-rechargeable batteries, filament units, filter, lamps, fuses etc. The Seller shall be released from all obligations under this warranty in the event repairs or modifications are made by persons other than its own or authorized service personnel or if the warranty claim results from physical abuse or misuse of the product. No agent, employee or representative of the Seller has any authority to bind the Seller to any affirmation, representation or warranty concerning the goods sold under this contract. Seller makes no warranty concerning components or accessories not manufactured by the Seller, but will pass on to the Purchaser all warranties of manufacturers of such components.

THIS WARRANTY IS IN LIEU OF ALL OTHER WARRANTIES, EXPRESSED, IMPLIED OR STATUTORY, AND IS STRICTLY LIMITED TO THE TERMS HEREOF. SELLER SPECIFICALLY DISCLAIMS ANY WARRANTY OF MERCHANT ABILITY OR OF FITNESS FOR A PARTICULAR PURPOSE.

2. **Exclusive Remedy-** It is expressly agreed that Purchaser's sole and exclusive remedy for breach of the above warranty, for any tortious conduct of Seller, or for any other cause of action, shall be the repair and/or replacement at Seller's option, of any equipment or parts thereof, which after examination by Seller is proven to be defective.

Replacement equipment and/or parts will be provided at no cost to Purchaser, F.O.B. Seller's Plant. Failure of Seller to successfully repair any non-conforming product shall not cause the remedy established hereby to fail of its essential purpose.

3. **Exclusion of Consequential Damage-** Purchaser specifically understands and agrees that under no circumstances will seller be liable to purchaser for economic, special, incidental or consequential damages or losses of any kind whatsoever, including but not limited to, loss of anticipated profits and any other loss caused by reason of non-operation of the goods. This exclusion is applicable to claims for breach of warranty, tortious conduct or any other cause of action against seller.

Table of Contents

1. Instrument Safety	1-1
2. Description	2-1
2.1 Identifying the Unit	2-1
The PrimaX P Gas Monitor:	2-1
The PrimaX I Gas Monitor:	2-1
Figure 2-1. PrimaX Gas Monitor	2-1
2.2 Overview	2-2
Figure 2-2. PrimaX P Detailed View	2-2
Sensors	2-3
Optional Feature:Additional Modules Available for PrimaX Configurations	2-3
3. Installation	3-1
3.1 Mechanical Installation	3-1
Preparation	3-1
Wall or Pipe Mounting	3-2
3.2 Electrical Installation	3-3
▲ WARNING	3-3
▲ WARNING	3-3
Electrical Connection - PrimaX P	3-4
Figure 3-1. PrimaX P Terminal Connections	3-4
Figure 3-2. PrimaX P Three-wire Connection	3-4
Electrical Connection - PrimaX I	3-5
Figure 3-3. PrimaX I Terminal Connections	3-5
Figure 3-4. PrimaX I Two-wire Connection	3-5
4. Operation	4-1
4.1 Startup	4-1
Display Test	4-1
Software Version	4-1
Figure 4-1. Display Overview	4-1
Sensor	4-2

Range	4-2
Countdown	4-2
Normal Operation	4-2
4.2 Menu Sequence	4-2
Figure 4-2. Keypad Operating Buttons	4-2
Table 4-1. Menu Items	4-3
4.3 Calibration	4-3
General	4-3
Automatic Calibration	4-4
Manual Calibration	4-4
Calibration Steps	4-4
(M-01) - ZERO and SPAN Gas Calibration	4-4
(M-01) - Oxygen Calibration	4-5
(M-02) - ZERO Gas Calibration	4-5
4.4 Maintenance and Information	4-5
(M-03) - Show Span Gas Value	4-5
(M-04) - Setup Calibration	4-6
(M-05) - Sensor Exchange	4-6
▲ WARNING	4-6
Table 4-2. Sensor Exchange	4-7
(M-06) - LCD/LED Test	4-7
(M-07) - Loop Test	4-7
(M-08) - Device Information	4-7
(M-09) - Sensor Information	4-8
(M-10) - Range Selection	4-8
▲ WARNING	4-8
(M-00) - Reset Alarm	4-9
4.5 Password	4-9
4.6 Changeable Parameters	4-9
Table 4-3. Changeable Parameters	4-9
4.7 Optional HART Module and Relay	4-10
Electrical Installation	4-11
Figure 4-3. HART Ports	4-11
Figure 4-4. Location of Relay	4-11
Relay Operation Startup	4-12

Table 4-4. Menu Sequence	4-12
Relay Operation	4-12
(M-11) - Relay Info	4-12
Figure 4-5. Relay Terminals	4-12
(M-12) - Relay Setup	4-13
(M-13) - Relay Test	4-13
Changeable Parameters for Relays	4-14
Table 4-5. Changeable Parameters for Relays ..	4-14
Changeable Parameters with HART	4-14
Table 4-6. Changeable Parameters with HART ..	4-14
Output States	4-15
Table 4-7. Output States	4-15
Error Codes	4-15
Table 4-8. Error Codes	4-15
5. Maintenance	5-1
5.1 Changing the Sensors	5-1
Remove Interlock	5-1
Remove Bayonet Joint	5-1
▲ WARNING	5-1
Replace Sensor	5-2
6. Technical Data	6-1
6.1 Specifications	6-1
Table 6-1. Performance Specifications	6-1
6.2 Cable Lengths and Cross-sections	6-1
Table 6-2. Toxic Gases and Oxygen Sensors with 4 to 20 mA Signal Output (Two-wire Sensor)	6-1
Table 6-3. Catalytic Combustible Gas Sensor with 4 to 20 mA Signal Output (Three-wire Sensor)	6-1
Table 6-4. Toxic Gases and Oxygen Sensors with 4 to 20 mA Signal Output (Three-wire Sensor)	6-2
Table 6-5. Catalytic Combustible Gas Sensor with 4 to 20 mA Signal Output	

(Four-wire Sensor)	6-2
Table 6-6. Toxic Gases and Oxygen Sensors with 4 to 20 mA Signal Output (Four-wire Sensor)	6-2
Table 6-7. Wiring for Two-, Three-, and Four-Wire Versions	6-2
6.3 Performance Specifications	6-3
Table 6-8. Performance Specifications	6-3
6.4 List of Detectable Gases	6-3
Table 6-9. List of Detectable Gases	6-3
6.5 Sensor Response to Interferants	6-4
Table 6-10. Sensor Response to Interferants	6-4
Table 6-11. Sensor Response to Interferants with Reference to Propane	6-5
Table 6-12. Response Time (Diffusion Mode)	6-6
7. Approvals	7-1
7.1 Prima XI	7-1
7.2 Prima XP	7-1
7.3 Safety Integrity Levels	7-2
Special Conditions for SIL 2	7-2
Special conditions for SIL 3	7-2
Safety Relevant Parameters	7-2
Safety Relevant Parameters (40°C) Application with Relay	7-2
Safety Relevant Parameters (40°C), Application with 4-20 mA Current Output	7-4
8. Accessories	8-1
8.1 Calibration Cap	8-1
▲ WARNING	8-1
Figure 8-1. Calibration Cap	8-1
8.2 SensorGard	8-2
8.3 Flow Through Adapter	8-2
Figure 8-2. Sensor Gard	8-2
Figure 8-3. Flow Through Adapter	8-2
8.4 Duct Mounting Kit	8-3

Figure 8-4. Duct Mounting Kit	8-3
8.5 Pipe Mounting Kit	8-4
8.6 Sensor Tag	8-4
Figure 8-5. Pipe Mounting Kit	8-4
Figure 8-6. Sensor Tag	8-4
8.7 Sunshield	8-5
8.8 Universal HART Cable	8-5
Figure 8-7. Sunshield	8-5
Figure 8-8. Universal HART Cable	8-5
9. Spare Parts	9-1
Table 9-1. Parts List	9-1
10. Appendix	10-1
10.1 Output States	10-1
Table 10-1. Output States	10-1
10.2 Calibration Faults	10-2
Table 10-2. Calibration Faults	10-2
10.3 Error Codes	10-3
Table 10-3. Error Codes	10-3
10.4 Timeout	10-3
Table 10-4. Timeouts	10-3
10.5 Mechanical Installation	10-4
Dimensions	10-4
Figure 10-1. PrimaX P Outline Dimensions	10-4
Figure 10-2. PrimaX P Outline Dimensions	10-4
Figure 10-3. PrimaX I.S. Control Drawing	10-5
Table 10- 5. Installation Parameters	10-6
10.6 Wiring Diagrams	10-7
Figure 10-4. PrimaX I, Ex ia, Intrinsically Safe Wiring Diagram	10-7
Figure 10-5. PrimaX P, Ex d, Flameproof Wiring Diagram	10-8

1. Instrument Safety

1.1 General Description

The PrimaX Gas Monitor:

- is a fixed gas monitor for measuring oxygen, toxic gases, or combustible gases
- is suitable for indoor and outdoor applications such as the:
 - offshore industry
 - chemical and petrochemical industry
 - water and sewage industry
- signal can be used in combination with the following MSA control units for further applications:
 - SUPREMA Touch Gas Monitor
 - GasGard XL Wall Mount Controller
 - Model 9010/9020 Monitoring Systems
- is available in an explosion-proof or an intrinsically safe enclosure
- instruction manual must be read and observed when using the product. National regulations applicable in the user's country must also be followed for safe use.

1.2 Important Safety and Precautionary Measures

WARNINGS

1. Install, operate and maintain in strict accordance with instrument labels and this manual.
2. Verify that the Class, Group, and temperature ratings of the equipment agree with the actual area classification, and temperature extremes within a Hazardous Location.
3. Use only genuine MSA replacement parts when performing any maintenance procedures provided in this manual.
 - Failure to do so may seriously impair instrument performance.
4. As with all devices of this type, high levels of, or long exposure to, certain compounds in the tested atmosphere could contaminate the sensor. In atmospheres where the device may be exposed to such materials, calibration must be performed frequently to ensure that the operation is dependable and display indications are accurate.
5. Catalytic combustible gas sensors may produce low or zero response to combustible gas after exposure to substances such as Silicon, Silane, Silicate, Halide and compounds containing Fluorine, Chlorine, Iodine or Bromine.

FAILURE TO FOLLOW THE ABOVE CAN RESULT IN AN UNSAFE CONDITION AND PERSONS WHO RELY ON THIS PRODUCT FOR THEIR SAFETY COULD SUSTAIN SEVERE PERSONAL INJURY OR LOSS OF LIFE.



CAUTIONS

1. Calibrate frequently if used in atmospheres exposed to high levels of solvents or dust.
 - See Section 4.3 for calibration procedures.
2. Do not apply paint on or around the instrument.
 - Paint deposits on the Environmental Guard can interfere with the diffusion process.
3. Do not mount the sensing head in direct sunlight as this may cause the sensor to overheat.
4. Perform calibration checks periodically against a known concentration of gas.
 - The instrument is labeled with the factory calibration gas type and value.
5. Protect the PrimaX Gas Monitor from extreme vibration.
6. The device must be installed with the sensor inlet pointing downward to prevent particles or liquids from clogging the gas inlet.
7. Electrochemical sensors are sealed units containing a corrosive electrolyte. If a sensor develops leakage, it must be immediately removed from service and disposed of properly. Ensure that the electrolyte does not contact skin, clothing or circuitry; otherwise, personal injury and/ or equipment damage may result.
8. For correct measurements, the combustible gas sensors require an oxygen concentration greater than 10% Vol. Oxygen enriched atmospheres (greater than 21% Vol.) can affect the measurement and electrical safety of the gas monitor.

**FAILURE TO FOLLOW THE ABOVE CAN RESULT
IN PRODUCT DAMAGE AND/OR AN UNSAFE CONDITION.**

2. Description

2.1 Identifying the Unit



Figure 2-1. PrimaX Gas Monitor

The PrimaX P Gas Monitor:

- is an explosion-proof version in an aluminum enclosure for the detection of combustible gases, toxic gases, or oxygen.

The PrimaX I Gas Monitor:

- is a intrinsically safe version in a plastic enclosure for the detection of toxic gases or oxygen

2.2 Overview

The PrimaX Gas Monitor:

- is factory-calibrated and delivered ready for installation.
- is configured and calibrated for only one specific gas or vapor
- enclosures vary, depending on the particular version
- electrical parts and interfaces have the same basic functionality
- has a quick and easily replaceable sensor
- has a four-digit liquid crystal display (LCD)
- has a key pad with a cover
- has a detachable backplate for installation on a wall or on a pipe
- operates with a 4 to 20 mA output signal and has an IP 67 ingress protection rating.



- | | | | |
|---|-------------------------------|----|----------------------------|
| 1 | Terminal for power connection | 6 | Sensor |
| 2 | Keypad with cover | 7 | Green LED (PrimaX P only) |
| 3 | Connector for factory use | 8 | Yellow LED (PrimaX P only) |
| 4 | Display | 9 | Red LED (PrimaX P only) |
| 5 | Bayonet joint with interlock | 10 | Identification plate |

Figure 2-2. PrimaX P Detailed View

Sensors

DESCRIPTION	PrimaX P	PrimaX I
Detection of toxic gases	X	X
Detection of oxygen	X	X
Detection of combustible gases	X	--

Optional Feature:

Additional Modules Available for PrimaX Configurations

DESCRIPTION	PrimaX P	PrimaX I
HART Module	X	X
HART + Relays Module	X	--
HART + Relays Module with galvanically isolated analog output	X	--

For additional HART module information, see Section 4.7

3. Installation

- Check that the delivered components are complete and correct, referring to the shipping documents and the sticker on the shipment carton.
- Install the device where gas leaks are expected. The installation position depends on the gas density:
 - for gases lighter than air, install the gas monitor in the upper area of the room, under the ceiling
 - for gases heavier than air, install the gas monitor close to the ground.

Other considerations before installation:

- air movement may affect the ability of the gas monitor to detect gas
- the display on the front of the gas monitor must always be clearly visible
- make sure the mounting arrangement is correct for the gas monitor version.

3.1 Mechanical Installation

Preparation

1. Remove the backplate:
 - a. Unscrew the gas monitor.



- b. Remove it from the backplate by lifting up the lower edge.



Wall or Pipe Mounting

A pipe mounting kit:

- is necessary for pipe mounting
 - contains clamps and screws to mount the gas monitor on pipes and poles.
1. Install the backplate:
 - a. Use the two keyhole slots to attach the mounting plate to the wall with 6 mm diameter screws and suitable plugs.



- b. **For wall installation:** use the backplate as a template to drill the holes for the two fixing screws.

For pipe installation: use the pipe clip.

- c. Attach backplate to the wall or pipe clip with M6 x 20 screws:
 - The hitch points away from the wall or pipe.
 - The backplate straight edge is at the bottom.
2. Attach the gas monitor to the backplate:
 - a. Attach the gas monitor to the top of the back-plate.
 - b. Fold down the gas monitor until it sits flush on the backplate.



- c. Screw the gas monitor to the backplate.



3.2 Electrical Installation

WARNING

Be sure to install the gas monitor in accordance with National and local Wiring Regulations.

FAILURE TO FOLLOW THE ABOVE CAN RESULT IN AN UNSAFE CONDITION AND PERSONS WHO RELY ON THIS PRODUCT FOR THEIR SAFETY COULD SUSTAIN SEVERE PERSONAL INJURY OR LOSS OF LIFE.

- Shielded cable for measuring devices is recommended.
- Always observe maximum cable lengths and cross-sections; see Section 6.2.

WARNING

Water or impurities can penetrate the gas monitor through the cable. In hazardous areas, install the cable in a loop just before entry into the gas monitor or slightly bend cable to prevent water from entering.

The power supply is defined as 24 VDC. If the input supply voltage at the monitor terminal is less than 10 V, the gas monitor turns OFF.

Operating the PrimaX I version in hazardous areas requires an intrinsically safe power supply.

Electrical Connection - PrimaX P

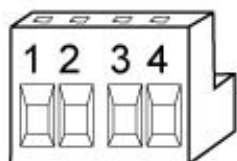

Terminal PrimaX P

- | | |
|---|--------------------------|
| 1 | Power supply (+), 24 VDC |
| 2 | Common |
| 3 | 4 to 20 mA (Signal) |
| 4 | empty |

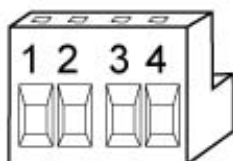

Terminal PrimaX P (with isolated mA output)

- | | |
|---|--------------------------|
| 1 | Power supply (+), 24 VDC |
| 2 | Common |
| 3 | 4 to 20 mA (Signal) |
| 4 | Isolated ground |

Figure 3-1. PrimaX P Terminal Connections

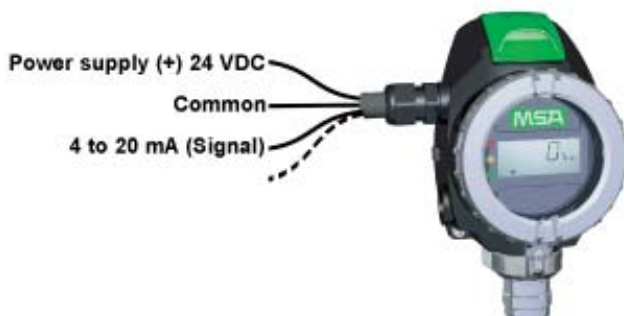
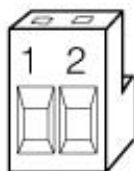

Figure 3-2. PrimaX P Three-wire Connection

1. Unscrew the interlock between the cover and the bayonet joint of the gas monitor.
2. Unscrew the aluminum enclosure lid.
3. Unplug the four-way terminal block, located behind the plastic cover above the display.
4. Insert a shielded connection cable into the gas monitor.
5. Connect the cable to the terminal.
6. Replace the enclosure lid, and secure the interlock.

Electrical Connection - PrimaX I



- 1 Power supply (+), 24 VDC
- 2 4 to 20 mA (Signal)

Figure 3-3. PrimaX I Terminal Connections

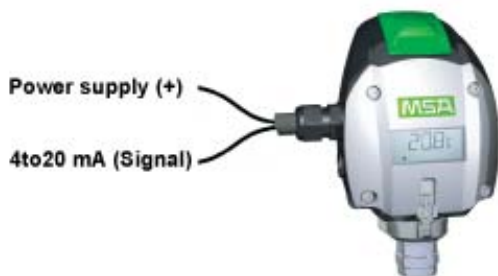

Figure 3-4. PrimaX I Two-wire Connection

1. Unbolt the four screws and remove the plastic cover.
2. Remove the two-way terminal block, located behind the plastic cover above the display.
3. Unscrew the clamping nut at the cable gland.
4. Place the clamping nut on the cable.
5. Insert the connection cable into the gas monitor.
6. Connect a two-wire, shielded cable to the terminal.
7. Tighten the cable gland clamping nut, ensuring that the cable cannot move within the cable gland.
8. Replace the plastic cover and secure the interlock.

4. Operation

The gas monitor is:

- configured and calibrated for only one specific gas or vapor.
- factory-calibrated
- delivered ready for installation.

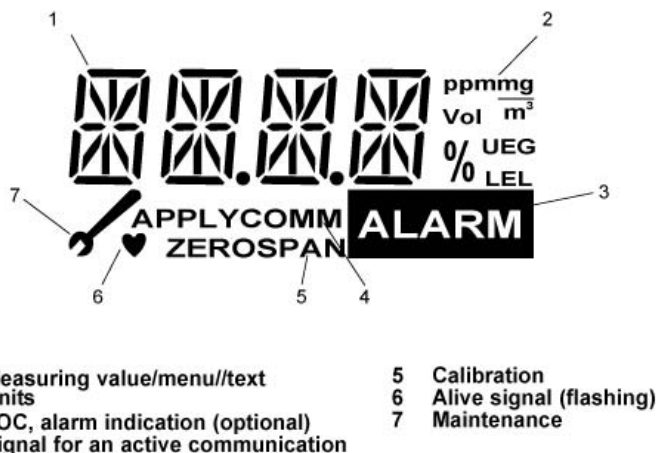

Figure 4-1. Display Overview

4.1 Startup

During startup:

- a self-test occurs
- the output signal is set to the service current (default: 3.0 mA)

The following information then displays:

Display Test

- All segments display.
- All LEDs display
- The yellow LED flashes during the startup procedure.

Software Version

The firmware version displays.

Sensor

The display shows the configured type of sensor operating with each detector, e.g., COMB (combustible), CO, H₂S.

Range

The display shows the measuring range predefined for the gas detector, e.g., 100% LEL.

Countdown

The sensor stability countdown displays.

Normal Operation

After countdown, the gas concentration (ppm, % Vol, % LEL, % UEG, mg/m³) displays and the heart symbol flashes to indicate "alive" status.

4.2 Menu Sequence

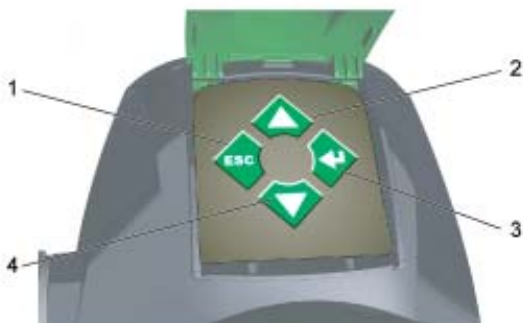

1 ESC button
2 UP button

3 ENTER button
4 DOWN button

Figure 4-2. Keypad Operating Buttons

Four buttons are used to navigate in the Menu sequence. In general:

1. Press the ENTER button to access the Menu sequence.
2. Press the UP or DOWN button until the desired Menu displays.
3. Press the ENTER button to access to the Menu.
4. Press the ESC button to cancel the process.

TABLE 4-1 lists the Menu items. Detailed descriptions can be found in Sections 4.3, 4.4 and 4.5.

Table 4-1. Menu Items

MENU ITEM	TEXT	PASSWORD?
M-01	Calibration	Yes
M-02	ZERO Calibration	Yes
M-03	Show Span Gas Concentration	No
M-04	Setup Calibration	Yes
M-05	Sensor Exchange	Yes
M-06	LCD and LED Test	No
M-07	Loop Test	Yes
M-08	Device Info	No
M-09	Sensor Info	No
M-10	Changing the Range	Yes
M-00	Reset Alarm	Yes

4.3 Calibration

General

The calibration must be done at regular intervals in accordance with applicable national and regional regulations. While the device is factory-calibrated, recalibration is recommended after installation. Calibration frequency depends on duration of use and sensor chemical exposure. New sensors must be calibrated frequently until calibration data indicates sensors have stabilized.

NOTE: Power the monitor for at least one hour before attempting calibration.

Calibrate before use and at regular intervals to ensure optimum sensor operation.

Connect all calibration components before beginning calibration, as it is necessary to apply span gas to the device during a countdown.

Calibration can be performed manually or automatically (see TABLE 4-1, Menu item M-04).

After starting any calibration step, calibration gas (zero or span gas) must be applied until the calibration step ends.

Automatic Calibration

After the automatic countdown displays, the calibration value displays until it stabilizes.

Manual Calibration

In Manual Calibration:

- The measuring value displays.
- When the calibration value stabilizes, press ENTER.
- The calibration step ends.

Calibration Steps

The calibration procedure can be cancelled at any time by pressing the ESC button; the previous calibration is then used.

(M-01) - ZERO and SPAN Gas Calibration

1. Press the ENTER button and select Menu 1.
2. Press the ENTER button.
3. Enter password (see Section 4.5).
4. Apply zero gas (zero air).

NOTE: Room air can be used if the ambient air is suitable, with no traces of the gas of interest.

5. Wait until countdown ends (automatic calibration)
or Press the ENTER button (manual calibration).
 - **OK** displays.
6. Apply span gas.
7. Wait until calibration completes (automatic calibration)
or Press the ENTER button (manual calibration).
 - **OK** displays.
 - Idle time countdown starts; the span gas can be removed.
 - The output signal remains on service current level.
8. Remove span gas during the countdown.

(M-01) - Oxygen Calibration

1. Press the ENTER button and select Menu 1.
2. Press the ENTER button.
3. Enter password (see Section 4.5).
4. Apply zero air
(or ensure that the sensor is exposed to clean air during this time).
5. Wait until countdown ends (automatic calibration)
or press the ENTER button (manual calibration).
 - OK displays.
6. The gas monitor goes to Measuring mode.

(M-02) - ZERO Gas Calibration

1. Press the ENTER button and select Menu 2.
2. Press the ENTER button.
3. Enter password (see Section 4.5).
4. Apply zero gas (zero air).

NOTE: Room air can be used if the ambient air is suitable,
with no traces of the gas of interest.

5. Wait until calibration ends (automatic calibration)
or press the ENTER button (manual calibration).
 - OK displays.
6. The gas monitor goes to Measuring mode.

4.4 Maintenance and Information

(M-03) - Show Span Gas Value

1. Press the ENTER button and select Menu 3.
2. Press the ENTER button.
 - The span gas concentration displays.
3. Press the ENTER button to return to the Menu
or ESC to return to the Measuring mode.

(M-04) - Setup Calibration

This Menu is used to set the gas concentration for span calibration and all calibration countdown times.

1. Press the ENTER button and select Menu 4.
2. Press the ENTER button.
3. Enter password (see Section 4.5).
4. Set the span gas concentration with the UP or DOWN button.
5. Press the ENTER button.
6. Set the zero calibration countdown time in seconds with the UP or DOWN button.

NOTE: Time = 0 (manual) zero calibration;
otherwise, an automatic calibration occurs.

7. Press the ENTER button.
8. Set the span calibration countdown in seconds with the UP or DOWN button. (See Section 4.6.)

NOTE: Time = 0 (manual) span calibration;
otherwise, an automatic calibration occurs.

9. Press the ENTER button.
10. Set the idle time countdown in seconds with the UP or DOWN button.
11. Press the ENTER button.

(M-05) - Sensor Exchange

This Menu starts the initial calibration and resets the sensor lifetime counter. Oxygen and Toxics sensors can be exchanged while unit is ON (hot swapped) with this function.



COMB sensors must not be exchanged while the unit is ON (hot swapped). (Only Oxygen and Toxics sensors can be exchanged with this Menu.)

For COMB sensors, this Menu performs the initial calibration only.

Table 4-2. Sensor Exchange

IF AN Oxygen and Toxics SENSOR IS CONNECTED	IF A COMB SENSOR IS CONNECTED
1. Press the ENTER button and select Menu 5	1. Press the ENTER button and select Menu 5
2. Press the ENTER button	2. Press the ENTER button
3. Enter password (see Section 4.5) An hourglass symbol appears to signify a 15-minute time span for user to change a sensor while unit is ON (hot swap) without triggering an error code	3. Enter password (see Section 4.5)
4. Change the sensor during this time span	4. Perform a ZERO and SPAN
5. Press the ENTER button or ESC to start the countdown	
6. Perform a ZERO and SPAN or Oxygen calibration (M-01)	

(M-06) - LCD/LED Test

NOTE: The LED Test is only available in the PrimaX P version.

In the LCD and LED Tests, all segments display and LEDs flash sequentially.

1. Press the ENTER button and select Menu 6.
2. Press the ENTER button.

(M-07) - Loop Test

In this Menu, a 4 to 20 mA Loop Test is performed.

1. Press the ENTER button and select Menu 7.
2. Press the ENTER button.
3. Enter password (see Section 4.5).
 - The loop test mA value displays (default value = 12 mA).
4. Press UP or DOWN to change the value.
5. Press the ENTER button to start the test.
6. Press the ENTER button to return to Menu or ESC to return to Measuring mode.

(M-08) - Device Information

Use the ENTER button to go through this Menu device information (gas type, measuring range, and firmware version).

(M-09) - Sensor Information

Use the ENTER button to go through this Menu information.

This Menu shows:

- the minimum and maximum measured gas concentrations which can be reset by holding the UP or DOWN button
- the sensor lifetime (in days) since sensor exchange (see M-05).

If a COMB or a TOX sensor is connected:

- this Menu shows the response time (as calculated during zero span calibration).

If an Oxygen and Toxics sensor is connected:

- this Menu shows the measured mV value.

If a COMB sensor is connected:

- this Menu shows the detector (U_D), compensator (U_K) and differential voltage (U_X) in mV.

(M-10) - Range Selection



WARNING

Span gas concentration must be checked, and the gas monitor must be calibrated if the range is changed.

This Menu allows the user to set up the optional measuring ranges for connected Oxygen and Toxics sensors.

1. Press the ENTER button and select Menu 10.
2. Press the ENTER button.
3. Enter password (see Section 4.5).
4. Press the UP or DOWN button to select the range and/or the measuring unit
 - TOX: ppm, mg/m³
 - COMB: LEL, UEG.
5. Press the ENTER button.
 - **OK** displays.
 - The calibration is set to invalid, and service current is supplied until recalibrated.

(M-00) - Reset Alarm

This Menu item is used to reset a combustible sensor or an alarm LOC. It appears only in the Menu if there is a latched LOC or alarm.

1. Press the ENTER button and select Menu 0.
2. Press the ENTER button.
3. Enter password (see Section 4.5).
 - Success message confirms that latched alarm is reset.

4.5 Password

Menus to be changed only by qualified and authorized persons are locked by a four-digit password. The default password is **0000**.

After entering the Password Menu, digit values are set from left to right:

1. Press the UP or DOWN button to change the value.
 - the value is increased or decreased.
2. Press the ENTER button to move to the next digit.
 - One digit can be backspaced by pressing the ESC button.
 - The password is validated once all four digits are entered.

4.6 Changeable Parameters

Table 4-3. Changeable Parameters

VALUES	DEFAULT	MINIMUM	MAXIMUM
Span Gas Value*	sensor: e.g., CO = 60 ppm, H ₂ S = 10 ppm, O ₂ = 20.8 % Vol, combustible = 50% LEL	10% of Range	100% of Range
Zero Calibration Time	30 s	0 seconds	2000 seconds
Span Calibration Time	30 s	0 seconds	2000 seconds
Idle Time after calibration	30 s		2000 seconds
Range		See Section 6.4	
Loop Test	12 mA	2 mA with 2-wire version; 0 mA with 3/4-wire version	22 mA

*CSA gas performance approval is only good for a calibration using 50% LEL.

4.7 Optional HART Module and Relay

The Highway Addressable Remote Transducer (HART) Protocol:

- makes use of the Bell 202 Frequency Shift Keying (FSK) standard to superimpose digital communication signals at a low level on top of the 4 to 20 mA signal
- provides two simultaneous communication channels:
 - a 4 to 20 mA analog signal, which communicates the primary measured value (in a field instrument) using the 4 to 20 mA current loop.
 - a digital signal, which communicates additional device information by using a digital signal superimposed on the analog signal.

The gas monitor:

- is available with an optional:
 - HART module or
 - module with HART and Relays for alarm and failure
- uses HART Protocol Revision 7.0
- can only communicate with HART Masters supporting Revision 7.0 or higher.

The following HART functions are also available:

- ZERO SPAN Calibration
- Oxygen Calibration
- ZERO Calibration
- Sensor Exchange
- LCD/LED Test
- Loop Test
- Range Setup
- Reset Alarm
- Readout of all Measured Data and Information.

Electrical Installation

NOTE: For wiring diagrams, see Section 10.6.



1 Optional HART port

Figure 4-3. HART Ports



1 Relay Terminals

Figure 4-4. Location of Relay

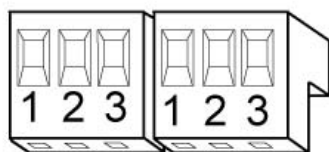

ALARM RELAY FAILURE RELAY

1	Normally-closed (NC), energized	1	Normally-closed (NC), energized
2	Common (COM)	2	Common (COM)
3	Normally-open (NO), energized	3	Normally-open (NO), energized

Figure 4-5. Relay Terminals

Relay Operation Startup

If relays are used, the alarm threshold displays at startup.

Table 4-4. Menu Sequence

MENU ITEM	TEXT	PASSWORD?
M-11	Relay Info	No
M-12	Relay Setup	Yes
M-13	Relay Test	Yes

Relay Operation

(M-11) - Relay Info

1. Press the ENTER button and select Menu 11.
2. Press the ENTER button.
3. Use the ENTER button to go through this Menu information:
 - alarm threshold and is alarm activated with a rising or falling gas concentration
 - if an alarm is to be latched
 - if alarm relay is energized at an alarm
 - if failure relay is energized at a failure.

(M-12) - Relay Setup

1. Press ENTER and select menu 12.
2. Press ENTER button.
3. Enter password [→chapter 4.5].
4. Set the alarm threshold with the UP or DOWN button.
5. Press ENTER button.
6. Set rising or falling alarm option with the UP or DOWN button.
7. Press ENTER button.
8. Set if latched with the UP or DOWN button.
9. Press ENTER button.
10. Set the alarm relay delay with the UP or DOWN button.
-Note: this parameter is fixed at '0' and is unchangeable.
11. Press ENTER button.
12. Set alarm relay energised at alarm option with the UP or DOWN button.
13. Press ENTER button.
14. Set the failure relay delay with the UP or DOWN button.
-Note: this parameter is fixed at '0' and is unchangeable.
15. Press ENTER button.
16. Set the failure relay energised at failure option with the UP or DOWN button.
17. Press ENTER button.

(M-13) - Relay Test

1. Press the ENTER button and select Menu 13.
2. Press the ENTER button.
3. Enter password (see Section 4.5).
 - The relays are now switched and can be tested.
4. Press the ENTER button to return to Menu or press ESC to return to Measuring mode.

Changeable Parameters for Relays

Table 4-5. Changeable Parameters for Relays

VALUES	DEFAULT	MINIMUM	MAXIMUM
Alarm threshold	30% of Range (O ₂ = 20% Vol)	5 % of Range	100% of Range
Alarm relay energized at alarm	no	yes	no
latch alarms	yes	yes	no
Alarming direction	O ₂ decrease; other increase	Increasing	decreasing
Alarm Delay Time	0 s	0 s	0 s
warning relay energized if warning	no	yes	no
warning relay delay time	0 s	0 s	0 s

Changeable Parameters with HART

- For all parameters that can be changed using the keypad, see Section 4.6.
- For relay parameters that can be changed using the keypad, see TABLE 4-5.

Table 4-6. Changeable Parameters with HART

VALUES	DEFAULT	MINIMUM	MAXIMUM
Password	0000	0000	9999
Tag	MSA	-	-
Description	PrimaX	-	-
Long tag		-	-
Message		-	-
Enable LOC if combustible	enable	enable	disable

Output States

Table 4-7. Output States

STATE	FAILURE RELAY	ALARM RELAY
Normal		
Startup	Startup state (default: switched)	
Calibration		
Latched voltage over-range	Switched	
Loop not connected	Switched	
Under-range	Switched	
Over-range	Switched	
Error	Switched	
Safety critical error	Switched	
LOC	Switched	
Latched LOC		Switched
Alarm threshold exceed		Switched

Switched: The relay state is switched from the normal state.
The normal state can be set to energized if alarm/failure or de-energized if alarm/failure. It can also be set to Normally de-energized if alarm/failure meets the ATEX and SIL requirements.

LOC: The PrimaX Gas Monitor was exposed to a high gas concentration (above the LEL), and the over-range condition may still exist.

Error Codes

Table 4-8. Error Codes

DISPLAY	CAUSE
E-40 - E-47	Relay error

5. Maintenance

5.1 Changing the Sensors

WARNING

Remove and re-install sensors carefully, ensuring that the components are not damaged; otherwise, the approval may be adversely affected, wrong readings could occur, and persons relying on this product for their safety could sustain serious personal injury or death.

If changing the sensor, reset the sensor lifetime counter (Section 4.2).

Remove Interlock

1. Unscrew the socket head screw.
2. Remove the interlock.



Remove Bayonet Joint

3. Turn the bayonet ring counter-clockwise.
4. Remove the bayonet ring by pulling it down.



Replace Sensor

5. Carefully unplug the sensor.
6. Carefully plug in the new sensor.
7. Replace the bayonet ring.
8. Replace the interlock.



For repair inquiries, dial 1-800-MSA-INST.

6. Technical Data

6.1 Specifications

Table 6-1. Performance Specifications

	PRIMAX P VERSION	PRIMAX I VERSION
Enclosure	aluminum enclosure flameproof IP 67 ingress protection	plastic enclosure intrinsically safe IP 67 ingress protection
Dimensions	8.66" H x 6.38" W x 3.94" D	220" H x 162" W x 3.19" D
Weight	3.5 lb. (1.6 kg)	2.6 lb. (1.2 kg)
Humidity	15% to 90% relative humidity	15% to 90% relative humidity
Power Supply	19.2 V to 28 V	19.2 V to 28 V
Power Consumption	3 W	0.7 W
Gas Monitor Temperature Range	-40 to +158°F (-40 to +70 °C)	-40 to +158°F (-40 to +70 °C)
Signal Output	4 to 20 mA	4 to 20 mA
HART Option	yes	yes
Relay Option	yes	no
Relays	2 A, 30 VDC	2 A, 30 VDC
Pressure	11.6 psi to 17.4 psi	11.6 psi to 17.4 psi
Maximum Load Resistance	300 Ohm	300 Ohm
Air Velocity	13.4 mph	13.4 mph

6.2 Cable Lengths and Cross-sections

NOTE: The maximum load resistance is 300 Ohms.

**Table 6-2. Toxic Gases and Oxygen Sensors
with 4 to 20 mA Signal Output (Two-wire Sensor)**

CROSS-SECTION	MAXIMUM LENGTH AT 24 VDC
14 AWG	9646 ft.
18 AWG	6430 ft.

**Table 6-3. Catalytic Combustible Gas Sensor
with 4 to 20 mA Signal Output (Three-wire Sensor)**

POWER SUPPLY CONFIGURATION	24 VDC WITHOUT RELAY	WITH RELAY
18 AWG; Cross-section	3215 ft.	2297 ft.
14 AWG; Cross-section 1.5 mm ²	4823 ft.	3445 ft.

**Table 6-4. Toxic Gases and Oxygen Sensors
with 4 to 20 mA Signal Output (Three-wire Sensor)**

POWER SUPPLY CONFIGURATION	24 VDC	
	WITHOUT RELAY	WITH RELAY
14 AWG	19,291 ft.	9842 ft.
18 AWG	12,861 ft.	6562 ft.

**Table 6-5. Catalytic Combustible Gas Sensor
with 4 to 20 mA Signal Output (Four-wire Sensor)**

POWER SUPPLY CONFIGURATION	24 VDC	
	WITHOUT RELAY	WITH RELAY
14 AWG Cross-section 1.5 mm ²	3500 ft.	2067 ft.
18 AWG Cross-section 1.0 mm ²	2001 ft.	1378 ft.
Maximum load resistance at signal output	300 Ohm	

**Table 6-6. Toxic Gases and Oxygen Sensors
with 4 to 20 mA Signal Output (Four-wire Sensor)**

POWER SUPPLY CONFIGURATION	WITH RELAY
14 AWG	6758 ft.
18 AWG	6063 ft.

Table 6-7. Wiring for Two-, Three-, and Four-Wire Versions

VERSION	WIRE	MINIMUM SUPPLY VOLTAGE
Two-wire	18 AWG; 1 mm ²	19.2 VDC
Three-wire	14 AWG; 1.5 mm ²	19.2 VDC
Four-wire	14 AWG; 1.5 mm ²	19.2 VDC

6.3 Performance Specifications

Table 6-8. Performance Specifications

WARM UP TIME	Combustible	95 seconds
	Oxygen and Toxics	36 seconds
STORAGE TEMPERATURE	0°C to +40°C or limits of the sensor	

6.4 List of Detectable Gases

Table 6-9. List of Detectable Gases

GAS	DEFAULT RANGE	SELECTABLE RANGE(S)	TEMPERATURE RANGE
Methane (CH ₄)	100% LEL	--	-40 to 70°C
Propane (C ₃ H ₈)	100% LEL	--	-40 to 70°C
Oxygen (O ₂)	25% Vol.	10% Vol.	-30 to 55°C
Carbon Monoxide (CO)	200 ppm	100 ppm 500 ppm 1000 ppm	-20 to 50°C
Hydrogen Sulfide (H ₂ S)	50 ppm	10 ppm 20 ppm 100 ppm	-40 to 50°C
Ammonia (NH ₃)	100 ppm	50 ppm	-20 to 40°C
Ammonia (NH ₃)	500 ppm	1000 ppm	-20 to 40°C
Chlorine (Cl ₂)	10 ppm	5 ppm	-20 to 40°C
Sulfur Dioxide (SO ₂)	50 ppm	10 ppm 20 ppm 100 ppm	-20 to 50°C
Hydrogen Cyanide (HCN)	30 ppm	10 ppm 20 ppm 50 ppm	-40 to 40°C
Hydrogen Chloride (HCl)	30 ppm	10 ppm 20 ppm	-20 to 40°C
Hydrogen (H ₂)	1000 ppm	-	-20 to 50 °C
Nitrogen Dioxide (NO ₂)	10 ppm	20 ppm 100 ppm	-20 to 50°C
Nitric Oxide (NO)	100 ppm	-	-30 to 50 °C

6.5 Sensor Response to Interferants

Table 6-10. Sensor Response to Interferants

Interference factors may differ from sensor to sensor and with lifetime. It is not advisable to calibrate with interference gases. This table does not claim to be complete. The sensor might also be sensitive to other gases.

GAS	INTERFERANT		
Oxygen (O ₂)			
Carbon Monoxide (CO)			
Hydrogen Sulfide (H ₂ S)	100 ppm Cl ₂ -9 ppm	100 ppm NO ₂ -21 ppm	100 ppm NO 1 ppm
	100 ppm HCN 1 ppm	100 ppm SO ₂ 1 ppm	
Ammonia (NH ₃)	20 ppm H ₂ S 2 ppm		
Ammonia (NH ₃)	20 ppm H ₂ S 2 ppm	20 ppm SO ₂ -40 ppm	
Chlorine (Cl ₂)	1 ppm Br ₂ 1 ppm	2.4 ppm ClO ₂ 0.55 ppm	20 ppm H ₂ S 0.1 ppm
	10 ppm NO ₂ 4.5 ppm	0.25 ppm O ₃ 0.11 ppm	
Chlorine (Cl ₂) (Exposure to H ₂ S will poison the cell)	1 ppm Br ₂ 1 ppm	1 ppm ClO ₂ 0.55 ppm	1 ppm F ₂ 0.4 ppm
	10 ppm NO ₂ 2 ppm	0.25 ppm O ₃ 0.05 ppm	20 ppm SO ₂ 3.5 ppm
Sulfur Dioxide (SO ₂)	300 ppm CO <3 ppm	5 ppm NO ₂ -5 ppm	
Hydrogen Cyanide (HCN)	100 ppm NO -5 ppm	10 ppm NO ₂ -7 ppm	
Hydrogen Chloride (HCl)	100 ppm NH ₃ 0.1 ppm	0.2 ppm AsH ₃ 0.7 ppm	5 ppm Cl ₂ 0.3 ppm
	20 range HCN 7 ppm	20 range H ₂ S 13 ppm	100 range NO 45 ppm
	10 ppm NO ₂ 0.3 ppm	0.1 ppm PH ₃ 0.3 ppm	20 ppm SO ₂ 8 ppm
Hydrogen (H ₂)	300 ppm CO <60 ppm	15 ppm H ₂ S <3 ppm	35 ppm NO 10 ppm
	100 ppm HCN 3 ppm	100 ppm C ₂ H ₄ 80 ppm	
Nitrogen Dioxide (NO ₂)	50 ppm NO ₂ <5 ppm	20 ppm SO ₂ <2 ppm	10 ppm Cl ₂ <15 ppm
	400 ppm H ₂ <0.1 ppm	20 ppm H ₂ S <15 ppm	400 ppm CO <0.1 ppm
	20 ppm NH ₃	<0.1 ppm	

GAS	INTERFERANT		
Nitric oxide (NO)	50 ppm NO	20 ppm SO ₂	10 ppm Cl ₂
	<0.5 ppm	<-2.5 ppm	100 ppm
	400 ppm H ₂	20 ppm H ₂ S	400 ppm CO
	<0.1 ppm	<-40 ppm	<0.1 ppm
	20 ppm NH ₃	50 ppm C ₂ H ₂	
	<0.1 ppm	<0.1 ppm	

Table 6-11. Sensor Response to Interferants with Reference to Propane

These values are only valid for new sensors and, unless otherwise stated, refer to an ambient temperature of 20°C.

SAMPLE GAS	100% LEL IN VOL%	PROPANE RELATIVE RESPONSE FACTOR	RESPONSE TIME(S) (t50)*	RESPONSE TIME(S) (t90)*
Propane	2.1 % Vol	1.00	≤ 14	≤ 24
2-Butanone	1.4 % Vol	1.13	≤ 12	≤ 31
Acetone	2.5 % Vol	0.94	≤ 9	≤ 24
Ethanol	3.3 % Vol	0.89	≤ 11	≤ 31
Ethyl Acetate	2.0 % Vol	1.12	≤ 13	≤ 46
Gasoline	1.4 % Vol	1.40	≤ 10	≤ 21
1-Propanol	2.2 % Vol	0.98	≤ 10	≤ 50
2-Propanol	2.0 % Vol	1.04	≤ 11	≤ 25
Propene	2.0 % Vol	0.85	≤ 8	≤ 19
Toluene	1.1 % Vol	1.22	≤ 15	≤ 46
Hydrogen	4.0 % Vol	0.53	≤ 6	≤ 16

*Response times are with a flow through adapter and a gas flow of 1 l/min.

Table 6-12. Response Time (Diffusion Mode)

These values are only valid for new sensors and, unless otherwise stated, they refer to an ambient temperature of 20°C.

GAS	RECOVERY TIME		RESPONSE TIME	
	t20	t90	t20	t10
Oxygen	≤ 8s	≤ 25s	≤ 8s	≤ 25s
Toxic		t90		t10
CO		≤ 20s		≤ 44s
H ₂ S		≤ 12s		≤ 32s
Combustible	t50*	t90*	t50*	t10*
Methane	≤ 10s	≤ 18s	≤ 10s	≤ 18s
Propane	≤ 12	≤ 20s	≤ 12	≤ 20s
Hydrogen	≤ 10	≤ 18s	≤ 10s	≤ 18s

*Response times are with a flow through adapter and a gas flow of 1 l/min.

7 Approvals

7.1 Prima XI

USA and Canada



Class I, Div. 1, Groups A, B, C, D
Class II, Groups E, F, G, Class III
Ambient temperature: -40°C to +70°C T4

NOTE: See instrument label for the approvals that apply to your specific unit.

7.2 Prima XP

USA



Class I, Div. 1, Groups A, B, C, D
Class II, Groups E, F, G, Class III
Ambient temperature: -40°C to +70°C

Canada



Class I, Div. 1, Groups B, C, D
Ambient temperature: -40°C to +70°C
CSA 22.2 NO 152
ISA 12.13

NOTE: See instrument label for the approvals that apply to your specific unit.

7.3 Safety Integrity Levels

Special Conditions for SIL 2

- Use of the sensors in a High Demand or Continuous Mode is allowed only in a 1002 - structure.
- Sensor outputs (4-20 mA - loops and relay contacts) must be monitored regarding deviations.

Special conditions for SIL 3

- Use of the sensors is allowed only in a 1002 - structure.
- Sensor outputs (4-20 mA - loops and relay contacts) must be monitored regarding deviations.

Safety Relevant Parameters

Safety Relevant Parameters (40°C) Application with Relay

GAS	λ_{TOTAL} FIT	λ_S FIT	λ_D FIT	λ_{DU} FIT	λ_{DD} FIT
Oxygen (O ₂)	6044	3622	2422	655	1767
Combustible	6666	3933	2733	1066	1667
Carbon Monoxide (CO)	3187	2194	994	255	739
Hydrogen Sulfide (H ₂ S)	3187	2194	994	255	739
Ammonia (NH ₃)	3737	2469	1269	415	854
Chlorine (Cl ₂)	4332	2766	1566	589	978
Sulfur Dioxide (SO ₂)	4297	2749	1549	578	970
Hydrogen Cyanide (HCN)	3995	2598	1398	490	907
Hydrogen Chloride (HCl)	4297	2749	1549	578	970
Hydrogen (H ₂)	3737	2469	1269	415	854
Nitrogen Dioxide (NO ₂)	4237	2718	1518	561	958
Nitrogen Oxide (NO)	4877	3039	1839	748	1091

GAS	SFF %	DC %	PFD _{1k}	PFD _{1k} % of SIL 2	PFD _{2k}
Oxygen (O ₂)	89.2	73.0	8.8E-04	8.8	1.9E-05
Combustible	84.0	61.0	1.4E-03	14.3	3.1E-05
Carbon Monoxide (CO)	92.0	74.4	3.4E-04	3.4	7.0E-06
Hydrogen Sulfide (H ₂ S)	92.0	74.4	5.6E-04	3.4	7.0E-06
Ammonia (NH ₃)	88.9	67.3	7.9E-04	5.6	1.2E-05
Chlorine (Cl ₂)	86.4	62.4	7.8E-04	7.9	1.7E-05
Sulfur Dioxide (SO ₂)	86.5	62.7	5.6E-04	7.8	1.6E-05
Hydrogen Cyanide (HCN)	87.7	64.9	7.5E-04	6.6	1.4E-05
Hydrogen Chloride (HCl)	86.5	62.7	1.0E-04	7.8	1.6E-05
Hydrogen (H ₂)	88.9	67.3	7.8E-04	5.6	1.2E-05
Nitrogen Dioxide (NO ₂)	86.8	63.1	7.5E-04	7.5	1.6E-05
Nitrogen Oxide (NO)	84.7	59.3	1.0E-03	10.0	2.1E-05

GAS	PFD _{2k} % of SIL 3	PFD _{2k} 1/h	PFD _{2k} % of SIL 1	PFD _{2k} 1/h	PFD _{2k} % of SIL 3
Oxygen (O ₂)	1.9	6.5E-07	6.5	1.4E-08	14.2
Combustible	3.1	1.1E-06	10.7	2.4E-08	24.2
Carbon Monoxide (CO)	0.7	2.5E-07	2.5	5.3E-09	5.3
Hydrogen Sulfide (H ₂ S)	0.7	2.5E-07	2.5	5.3E-09	5.3
Ammonia (NH ₃)	1.2	4.2E-07	4.2	8.7E-09	8.7
Chlorine (Cl ₂)	1.7	5.9E-07	5.9	1.3E-08	12.7
Sulfur Dioxide (SO ₂)	1.6	5.8E-07	5.8	1.2E-08	12.4
Hydrogen Cyanide (HCN)	1.4	4.9E-07	4.9	1.0E-08	10.4
Hydrogen Chloride (HCl)	1.6	5.8E-07	5.8	1.2E-08	12.4
Hydrogen (H ₂)	1.2	4.2E-07	4.2	8.7E-09	8.7
Nitrogen Dioxide (NO ₂)	1.6	5.6E-07	5.6	1.2E-08	12.0
Nitrogen Oxide (NO)	2.1	7.5E-07	7.5	1.6E-08	16.4

Safety Relevant Parameters (40°C), Application with 4-20 mA Current Output

GAS	λ_{TOTAL} FIT	λ_S FIT	λ_D FIT	λ_{DU} FIT	λ_{DD} FIT
Oxygen (O ₂)	4040	2020	2020	602	1418
Combustible	4662	2331	2331	1013	1318
Carbon Monoxide (CO)	1183	592	592	202	389
Hydrogen Sulfide (H ₂ S)	1183	592	592	202	389
Ammonia (NH ₃)	1734	867	867	363	504
Chlorine (Cl ₂)	2328	1164	1164	536	628
Sulfur Dioxide (SO ₂)	2294	1147	1147	526	621
Hydrogen Cyanide (HCN)	1992	867	867	438	558
Hydrogen Chloride (HCl)	2294	1117	1117	526	621
Hydrogen (H ₂)	1734	1437	1437	363	504
Nitrogen Dioxide (NO ₂)	2233	1147	1147	509	608
Nitrogen Oxide (NO)	2874	1437	1437	695	741

GAS	SFF %	DC %	PFD _{1k}	PFD _{1k} % of SIL 2	PFD _{2k}
Oxygen (O ₂)	85.1	70.2	8.1E-04	8.1	1.7E-05
Combustible	78.3	56.5	1.4E-03	13.6	3.0E-05
Carbon Monoxide (CO)	82.9	65.8	2.7E-04	2.7	5.5E-06
Hydrogen Sulfide (H ₂ S)	82.9	65.8	2.7E-04	2.7	5.5E-06
Ammonia (NH ₃)	79.1	58.1	4.9E-04	4.9	1.0E-05
Chlorine (Cl ₂)	77.0	53.9	7.2E-04	7.2	1.5E-05
Sulfur Dioxide (SO ₂)	77.1	54.1	7.1E-04	7.1	1.5E-05
Hydrogen Cyanide (HCN)	78.0	56.0	5.9E-04	5.9	1.2E-05
Hydrogen Chloride (HCl)	77.1	54.1	7.1E-04	7.1	1.5E-05
Hydrogen (H ₂)	79.1	58.1	4.9E-04	4.9	1.0E-05
Nitrogen Dioxide (NO ₂)	77.2	54.5	6.8E-04	6.8	1.4E-05
Nitrogen Oxide (NO)	75.8	51.6	9.3E-03	9.3	2.0E-05

GAS	PFD _{2k} % of SIL 3	PFD _{2k} 1/h	PFD _{2k} % of SIL 1	PFD _{2k} 1/h	PFD _{2k} % of SIL 3
Oxygen (O ₂)	1.7	6.0E-07	6.0	1.3E-08	13.0
Combustible	3.0	1.0E-06	10.1	2.3E-08	22.9
Carbon Monoxide (CO)	0.6	2.0E-07	2.0	4.2E-09	4.2
Hydrogen Sulfide (H ₂ S)	0.6	2.0E-07	2.0	4.2E-09	4.2
Ammonia (NH ₃)	1.0	3.6E-07	3.6	7.6E-09	7.6
Chlorine (Cl ₂)	1.5	5.4E-07	5.4	1.1E-08	11.5
Sulfur Dioxide (SO ₂)	1.5	5.3E-07	5.3	1.1E-08	11.2
Hydrogen Cyanide (HCN)	1.2	4.4E-07	4.4	9.3E-09	9.3
Hydrogen Chloride (HCl)	1.5	5.3E-07	5.3	1.1E-08	11.2
Hydrogen (H ₂)	1.0	3.6E-07	3.6	7.6E-09	7.6
Nitrogen Dioxide (NO ₂)	1.4	5.1E-07	5.1	1.1E-08	10.8
Nitrogen Oxide (NO)	2.0	7.0E-07	7.0	1.5E-08	15.2

8. Accessories

See Section 8.5 for part numbers.

8.1 Calibration Cap

Using calibration cap allows span gas calibration procedure to be accurate in windy environmental conditions.

The calibration cap is pushed onto the front of the sensor and is sealed by an O-ring. The surface area $S < 20 \text{ cm}^2$.



Figure 8-1. Calibration Cap



WARNING

The calibrating cap must be removed after completing the calibration.

The gas is supplied via either of the gas inlets by means of suitable flexible tube.

8.2 SensorGard



Figure 8-2. Sensor Gard

- The SensorGard should be fitted at all times, except when using the flow through adapter or Duct Mount Kit.
- Ambient weather conditions can affect the gas mixture inside the SensorGard.
- Use the SensorGard for functional test only.
- Calibration cap is recommended for sensor calibration.

NOTE: Using the sensor gard extends the response time, depending on the gas flow rate.

8.3 Flow Through Adapter



Figure 8-3. Flow Through Adapter

- Gas inlet/outlet thread: 1/8" NPT

NOTE: Using the flow through adapter extends the response time, depending on the gas flow rate.

8.4 Duct Mounting Kit



Figure 8-4. Duct Mounting Kit

- Gas monitoring in air ducts can be performed by using the Duct Mounting Kit.
- When installing, the direction of flow inside the duct must be toward the baffles.
- The gas monitor can be calibrated via the gas calibration port if the duct is free of all gases to which the sensor responds. If the duct cannot be gas-free, remove the sensor from the duct during calibration.
- The calibration port must be sealed with the locking cap after calibration.
- Calibration should only be performed with the calibration port if the air velocity is 11.2 mph in the air duct.

NOTE: Duct Mounting kit performance depends on various parameters and must be checked before use. The kit was not part of the compliance test.

8.5 Pipe Mounting Kit



Figure 8-5. Pipe Mounting Kit

- The Pipe Mounting kit contains clamps and screws to mount the device on pipes and poles.

8.6 Sensor Tag



Figure 8-6. Sensor Tag

- The stainless steel label allows user to identify and tag the location or installation of the instrument on the site.

8.7 Sunshield



Figure 8-7. Sunshield

- Stainless steel plate protects the gas monitor from direct sunlight.

8.8 Universal HART Cable



Figure 8-8. Universal HART Cable

- Universal cable connects the PrimaX Gas Monitor to any standard HART handheld device (e.g., Emerson 375) using the HART connector.

9 Spare Parts

Table 9-1. Parts List

PART	PART NO.
ACCESSORIES	
Sensor Gard, plastic	10113033
Flow Through Adapter, stainless steel, 316	10113031
Duct Mounting Kit, stainless steel, 316	10112790
Pipe Mounting Kit, stainless steel, 316	10113032
Sensor Tag, stainless steel, 316	10113034
Sunshield, stainless steel, 316	10113035
Calibration Cap, plastic	10112789
Universal HART Cable (1.5 m)	10113036
PRIMAX I REPLACEMENT PARTS	
Bayonet lock plate and screw	10113042
Sensor bayonet and cap	10113048
Mounting plate	10113041
Lid	10113045
Lid screws (set of four)	10113046
Keyboard cover	10113040
Cable gland M25 x 1.5, 7 to 17 mm	10113039
PRIMAX P REPLACEMENT PARTS	
Bayonet lock plate & screw	10113050
Sensor bayonet and cap	10113058
Mounting plate	10113041
Lid	10113056
Keyboard cover	10113040
Cable gland Ex d II CT4 M25 x 1.5	10113038
Cable gland Ex d II CT4 ¾" NPT	10113037
SENSORS	
PrimaX P Catalytic Sensor Combustible Gases, 100% LEL	10112716
Oxygen (O ₂), 0 to 25% Vol. (10% Vol.)	10112718
Carbon Monoxide (CO), 200 ppm (100 ppm, 500 ppm, 1000 ppm)	711306
Hydrogen Sulfide (H ₂ S) 50 ppm (10 ppm, 20 ppm, 100 ppm)	711307
Ammonia (NH ₃) 100 ppm (50 ppm)	10080225
Ammonia (NH ₃) 1000 ppm (500 ppm)	10112719
Chlorine (Cl ₂) 10 ppm (5 ppm)	10112720
Sulfur Dioxide (SO ₂) 50 ppm (10 ppm, 20 ppm, 100 ppm)	10080223

SENSORS	PART NO.
Hydrogen Cyanide (HCN) 30 ppm (10 ppm, 20 ppm, 50 ppm)	10080220
Hydrogen Chloride (HCl) 30 ppm (10 ppm, 20 ppm)	10112721
Hydrogen (H ₂) 1000 ppm	10112723
Nitrogen Dioxide (NO ₂) 10 ppm (20 ppm, 100 ppm)	10080224
Nitrogen Oxide (NO) 100 ppm	10112724

- Order electrochemical sensors for immediate replacement only.
- Storage temperature should be in the range of 5 to 12°C.
- Correctly dispose of electrochemical sensors.

10. Appendix

10.1 Output States

Table 10-1. Output States

DISPLAY	ALTER-NATING	LED COLOR	STATE	SIGNAL CURRENT	DEFAULT
		Green	Normal	4 to 20 mA	
		Yellow (flashing)	Startup	Service current	3 mA
		Yellow (flashing)	Calibration	Service current	3 mA
CAL	X	Yellow	Calibration invalid	Service current	3 mA
VCC ▲	X	Yellow	Latched voltage over-range (confirm on device)	Service current	3 mA
LOOP	X	Yellow	Loop not connected PrimaX P		
LO ▼	X	Yellow	Under-range (< -10%)	Error current	2 mA
LO ▼	X	Green	Under-range (< -2%) TOX (< -5%) combustible	3.8 - 4 mA	
		Red	Alarm	4 - 20 mA	
		Red (flashing)	Latched alarm	4 - 20 mA	
HI ▲	X	Green	Over-range	20 - 20.5 mA	
E-XX		Yellow	Error	Error current	2 mA
E-XX		Yellow	Safety critical error	Open loop	
					<ul style="list-style-type: none"> • 0 mA PrimaX P • < 2 mA PrimaX I
LOC	X	Red	LOC (if combustible)	20.5 mA	
LOC	X	Red (flashing)	Latched LOC (if combustible)	20.5 mA	

10.2 Calibration Faults

Table 10-2. Calibration Faults

DISPLAY	CAUSE
Fault -1	Zero not stable
Fault -2	Zero too low
Fault -3	Zero too high
Fault -4	Span not stable
Fault -5	Span too low
Fault -6	Span too high
Fault -7	Not enough resolution
Fault -8	Catalytic sensor values out of technical specification

10.3 Error Codes

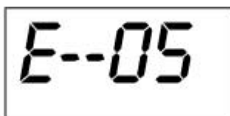

If an error is detected:

- The Error code **E**, a numeric code, and a short description display
- The gas monitor does not respond to gas
- The output signal current is the ERROR value (default 2 mA)
- Normal gas monitor operation is not possible.
 - If the Error code still displays after a reset, the gas monitor may require service.

Table 10-3. Error Codes

DISPLAY	CAUSE
E-01 - E-19	Latched Hardware/Software Error
E-20 - E-29	Sensor Cell error
E-30 - E-39	Unlatched Hardware/Software Error
E-48	Device supply too high
E-49	Device supply too low

- Latched errors E-01 to E-29 are reset by pressing any key.
- Sensor errors E-20 to E-29 are cleared by:
 - checking that the sensor is well connected
 - changing the sensor
 - resetting the device.

10.4 Timeout

Table 10-4. Timeouts

TIMEOUT	LENGTH
Automatic calibration timeout	4 minutes
Manual calibration timeout	60 minutes (M-01, M-02)
Any test procedure (M-06, M-07) timeout	15 minutes
All other menu timeouts (if no button pressed)	2 minutes

10.5 Mechanical Installation

Dimensions

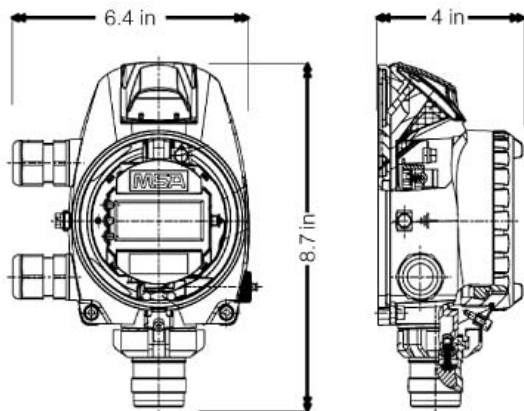

Figure 10-1. PrimaX P Outline Dimensions

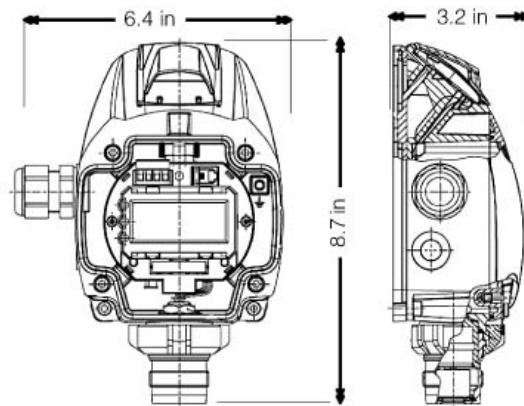

Figure 10-2. PrimaX P Outline Dimensions

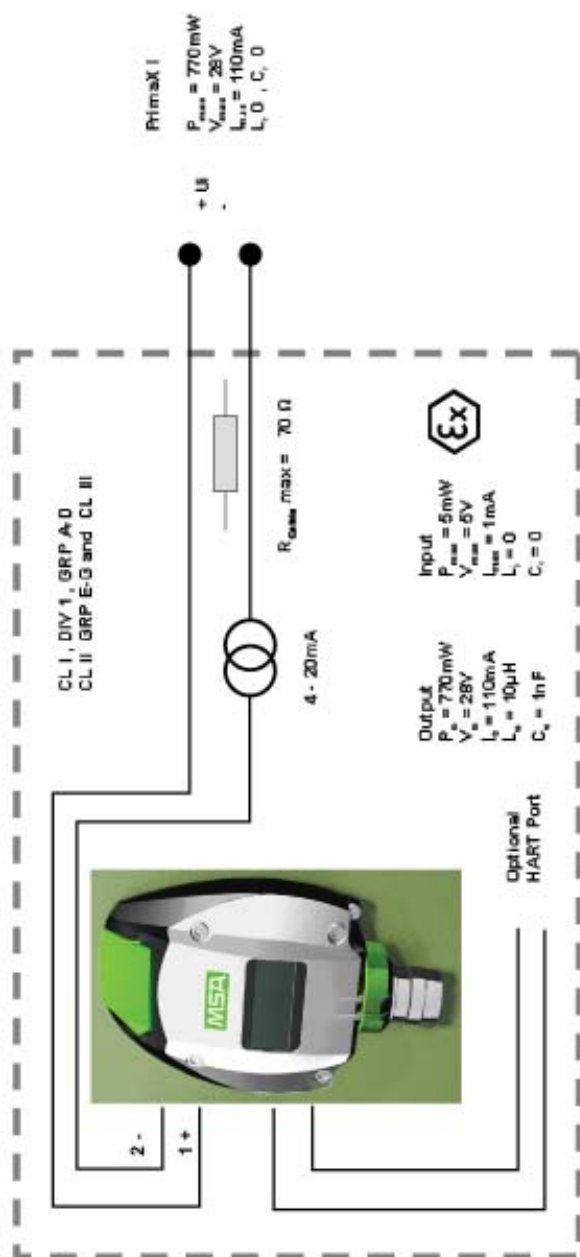

Figure 10-3. PrimaX I.S. Control Drawing

The Associated Apparatus (see FIGURE 10-3):

- must provide intrinsically safe circuits to the PrimaX I.
- must be installed in accordance with its manufacturer's control drawing and Article 504 of the National Electrical Code (ANSI/NFPA 70 for installation in the United States, or Section 18 of the Canadian Electrical Code for installations in Canada.

Capacitance and inductance of the field wiring from the intrinsically safe equipment to the associated apparatus shall be calculated and must be included in the system calculations as shown in TABLE 10-5.

Cable capacitance, C_{cable} , plus intrinsically safe equipment capacitance. C_i must be less than the marked capacitance C_a (or C_o), shown on any associated apparatus used. The same applies for inductance (L_{cable} , L_i , and L_a or L_o , respectively). Where the cable capacitance and inductance per foot are not known, the following values shall be used $C_{\text{cable}} = 60 \text{ p F/ft.}$, $L_{\text{cable}} = 0.2 \text{ }\mu\text{H/ft.}$

Table 10- 5. Installation Parameters

I.S. EQUIPMENT		ASSOCIATED APPARATUS
V_{max} (or U_i)	\geq	V_{oc} or V_t (or U_o)
I_{max} (or I_i)	\geq	I_{sc} or I_t (or I_o)
P_{max} (or P_i)	\geq	P_o
$C_i + C_{\text{cable}}$	\geq	C_a (or C_o)
$L_i + L_{\text{cable}}$	\geq	L_a (or L_o)

Selected barriers must be third-party approved as providing intrinsically safe circuits for the application, and:

- have V_{oc} or V_t not exceeding V_{max} and I_{sc} or not exceeding I_{max}
- the P_o of the barrier must be $\leq P_{\text{max}}$ of the intrinsically safe equipment (TABLE 10-5).

When required by the manufacturer's control drawing, the barrier must be connected to a suitable ground electrode per the National Electrical code (ANSI/NFPA 70) or the Canadian Electrical Code, as applicable. The resistance of the ground path must be $< 1 \text{ ohm.}$

Control equipment must not use or generate more than 250 V ms or dc with respect to earth.

10.6 Wiring Diagrams

The HART communications require a minimum of 250 ohms resistance in the 4 to 20 mA loop.

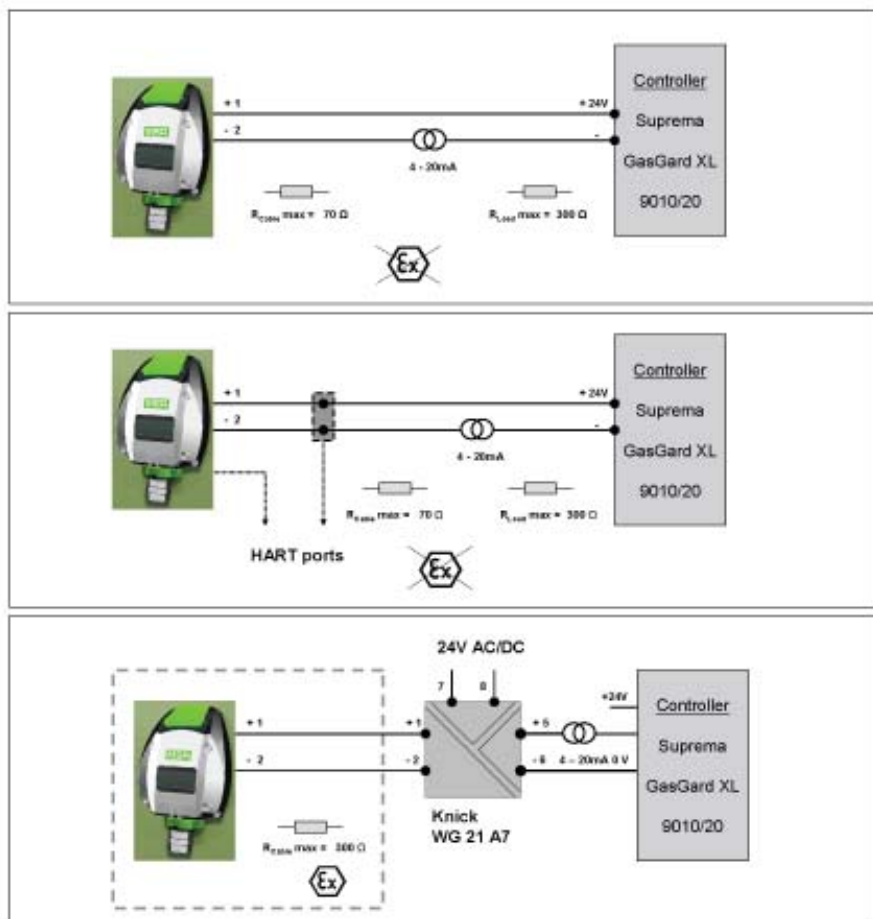

Figure 10-4. PrimaX I, Ex ia, Intrinsically Safe Wiring Diagram

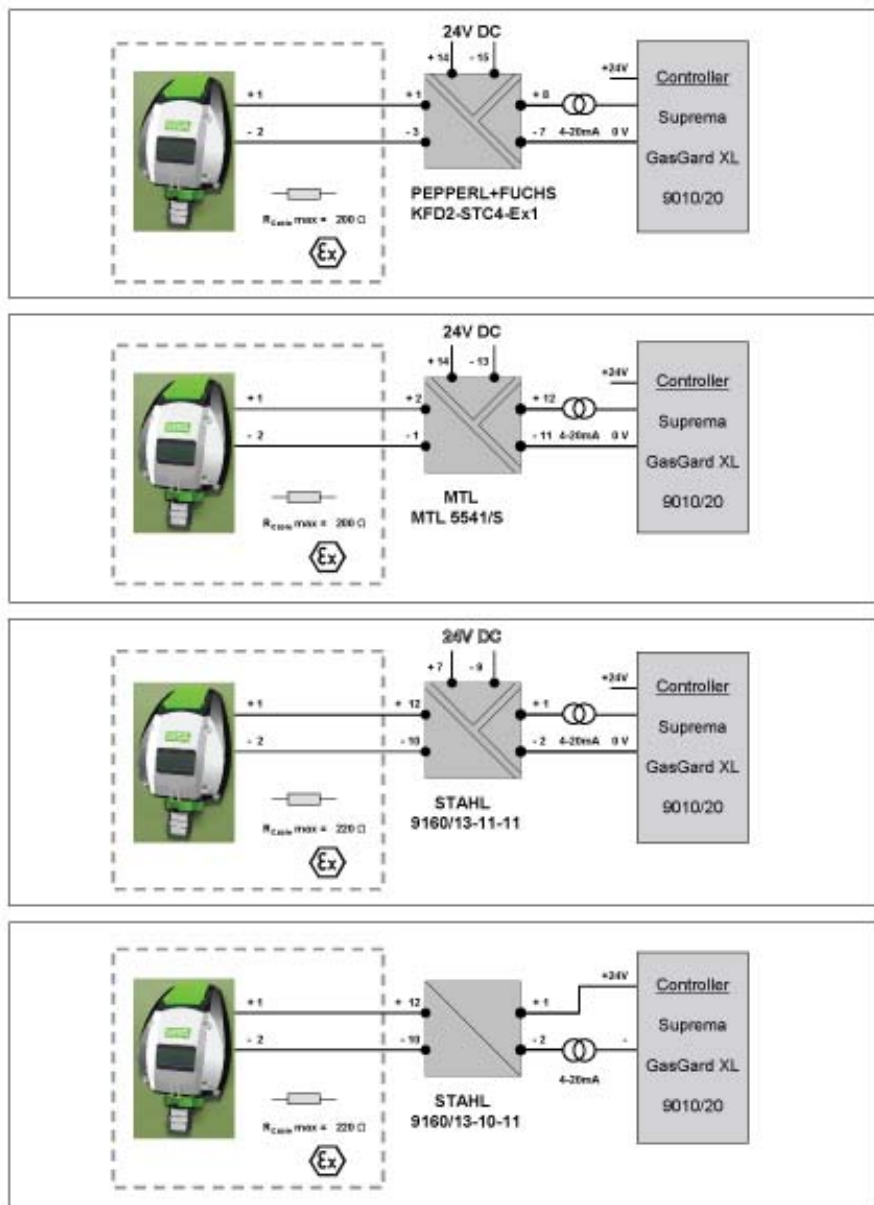



Figure 10-5. PrimaX P, Ex d, Flameproof Wiring Diagram

1	2	3	4	A	B	C	D	E
								
HART Port Parameter : Output $P_o = 185mW$ $V_{oc} = 2,7V$ $I_{sc} = 137mA$ $L_o = 10\mu H$ $C_o = 1nF$			Input $P_{max} = 5mW$ $V_{max} = 5V$ $I_{max} = 1mA$ $L_i = 0,7\mu H$ $C_i = 0,1nF$			I.S. Equipment Associated App. $V_{max} \text{ (or } U_i) \geq V_{max} \text{ or } V_i \text{ (or } U_i)$ $I_{max} \text{ (or } I_i) \geq I_{max} \text{ or } I_i \text{ (or } I_i)$ $P_{max} \text{ (or } P_i) \geq P_o$ $C_i \geq C_{cable}$ $L_i \geq L_{cable}$		
Table 1 HART Port Connector								
<ol style="list-style-type: none"> Selected intrinsically safe equipment must be third party listed as intrinsically safe for the application, and have intrinsically safe entity parameters conforming with Table 1. This relationship must be satisfied for both input and output parameters. Additionally, equipment connected to the HART PORT must not have output parameters that exceed the input parameters of the port. Intrinsically safe circuits must be wired and separated in accordance with Article 504.20 of the National Electrical Code (ANSI/NFPA 70) or other local codes, as applicable. This associated apparatus has not been evaluated for use in combination with another associated apparatus. For installations in which both the CI and LI of the intrinsically safe apparatus exceeds 1% of the Co and Lo parameters of the associated apparatus (excluding the cable), then 50% of Co and Lo parameters are applicable and shall not be exceeded. The intrinsically safe circuit does not provide 500 V isolation with respect to earth. Connected apparatus used must be galvanically isolated. Apparatus must be installed in accordance with its manufacturer's control drawing and Article 504 of the National Electrical Code (ANSI/NFPA 70) for installation in the United States, or Section 18 of the Canadian Electrical Code for installations in Canada. Equipment connected to the HART PORT must be installed in accordance with its manufacturer's control drawing and Article 504 of the National Electrical Code (ANSI/NFPA 70) for installation in the United States, or Section 18 of the Canadian Electrical Code for installations in Canada. 								
HART PORT Connection : Capacitance and inductance of the field wiring from the intrinsically safe equipment to the associated apparatus shall be calculated and must be included in the system calculations as shown in Table 1. Cable capacitance, C_{cable} plus intrinsically safe equipment capacitance, C_i , must be less than the marked capacitance, C_o (or C_o), shown on any associated apparatus used. The same applies for inductance (L_{cable} , L_i and L_o , respectively). Where the cable capacitance and inductance per foot are not known, the following values shall be used: $C_{cable} = 60 \text{ pF / ft.}$ $L_{cable} = 0,2 \mu\text{H / ft.}$								

MSA / Concessionaire in Iran 		Alignment / Tolérance Général / Tolérance 		Size / Taille / Mesure / Valeur 		Version / Révision 	
2012 Date / Date / Datum / Datum 22.05 Date / Date / Datum / Datum 22.05 Date / Date / Datum / Datum Dr. Schuberl Name / Nom / Nom / Nom Dr. Schuberl		Description / Description Typschild PrimaX P Control Drawing Label PrimaX P Control Drawing				Scale / Echelle / Scale No Scale	
 The Safety Company		Part No. / Désignation / Part No. DG0752044		Rev. / Révisé / Rev. / Révisé 102-11 / 102-11 102-11 / 102-11		Sheet / Page / Sheet / Page 3 / 3	
Rev. / Révisé / Rev. / Révisé Change No. / Changement / Change No. / Changement Date / Date / Datum / Datum Name / Nom / Nom / Nom		Désignation / Description / Désignation / Description DG0752044-B3-0dr		Scale / Echelle / Scale A4			