

## Flight helmet LH250



## Table of Contents

	<b>Page</b>
Table of Contents	1/25
- Warning notice	2/25
- Helmet description	3/25
- Warranty	3/25
- Introduction	4/25
1 – Chinstrap	5/25
2 – Inner liner elements	6/25
3 – Edge roll	7/25
4 – Inner visor	8/25
5 – Outer visor	9/25
6 – NVG hard cover	10/25
7 – Audio cable	11/25
8 – Microphone unit and cover (standard or winchman's)	12/25
9 – Combined microphone boom	13/25
10 – Microphone boom	14/25
11 – Removing the complete microphone	15/25
12 – Earphones and hygiene parts of the ear cups	16/25
Servicing and maintenance table	17/25
Inspection table and replacement criteria	18/25
Appendices: Replacement criteria	19 to 25/25

## WARNING NOTICE

**Thank you for putting your trust in MSA products.**

**Read these instructions carefully before using your helmet.**

Failure to follow these instructions could reduce the level of protection provided by your helmet.

**The level of protection provided by the helmet is only guaranteed if it has all the original MSA parts. Therefore,** any modifications made to your helmet or the absence of any of the parts forming the original helmet will make the equipment supplied non-compliant, releasing MSA from all liability.

**In order to keep improving its products, MSA reserves the right to modify them without prior notice.**

To provide sufficient protection, this helmet must be fitted and adjusted to the head size of its wearer.

The helmet is made in such a way that any energy received during an impact is absorbed by the destruction of or partial damage to the shell and impact cap; even if this damage is not immediately apparent, replacement of the whole helmet is recommended after a major impact.

Users' attention is also drawn to the danger of modifying or removing any of the original parts of the helmet except where the modification or removal is recommended by the helmet manufacturer. Under no circumstances should helmets be adapted so that accessories can be attached using a process not recommended by the helmet manufacturer.

Do not apply paints, solvents, adhesives or stickers, except those recommended by the helmet manufacturer's instructions.

**After any obvious impact an inspection should be carried out by the maintenance department or specialist workshop.**

**The MSA LH 250 flight helmet is designed solely for helicopter pilots and helicopter flight crew. It provides maximum comfort and protection.**

**It is available in two sizes, covering head circumferences from 52 cm to 64 cm. It has two visors and can be fitted with a wide range of communication systems, on request. Contact us for more details.**

Traceability is assured by a label showing a serial number.

# FLIGHT HELMET LH 250

## HELMET DESCRIPTION

### Description:

- **The shell** of the helmet consists of:
  - an outer shell made from high performance composites,
  - an expanded polystyrene impact cap to absorb shocks, covered with an inner liner.
- The **inner liner** consists of a T-shaped comfort liner and a neck pad. The helmet is adapted to the shape of the wearer's head by personalising the T-shaped comfort liner and the neck pad and the adjustment pads for adjusting the pressure of the ear cups on the ears.
- The helmet has **2 protective visors**, an inner visor and an outer visor.
- The **ear protection** system consists of:
  - two ear cups, containing a housing for installing the earphones.
  - two ergonomic comfort ear seals.The ear cups provide excellent ear protection and are fixed inside the shell by means of hook and loop pads.
- The helmet **chinstrap** is adjustable and fully removable.
- Every helmet is supplied with a **protective bag** and a **personalisation kit**.
- The helmet can accommodate a wide range of **communication systems** and **night vision goggle** fittings, on request.

## WARRANTY

All models, accessories and spares are subject to stringent checks before leaving the factory.

**MSA** helmets and accessories are guaranteed for 12 months, parts and labour, from the date of delivery to the buyer, against any failure during use under the conditions described in this manual.

You also have a statutory warranty against hidden faults and defects subject to the conditions laid down in Articles 1641 ff. of the French Civil Code.

## INTRODUCTION

**Important:** whenever you are handling the helmet, make sure you put it down on its carry bag.

Tools required:

- 7 mm flat spanner



- 2 mm hexagonal screwdriver



- Flat screwdriver



- Philips screwdriver



## 1. Chinstrap:

---

Tools: Philips screwdriver.  
Dismantling duration: 15 seconds.  
Mounting duration: 30 seconds.

The chinstrap is secured to the helmet by means of two screws on the left chinstrap bracket.

To remove the chinstrap, unscrew the screws on the left side, then take out the chinstrap levers by holding them by the ends.

To reinstall, engage each lever, making sure the chin cup is the right way round (the return part of the strap should be uppermost) and so are the levers. Lock by pressing in the middle of the lever. Tighten the 2 screws. You do not have to remove the chinstrap in order to take off the chin cup.

Important: when reinstalling, the screws should be tightened 1/8 of a turn from when the tightening stress increases (screwing into plastic).



Screws securing  
the chinstrap

## 2. Inner liner elements:

---

Tools: None.

Dismantling duration: 20 seconds.

Mounting duration: 45 seconds.

There are three inner liner elements:

The comfort liner with its interchangeable foam pieces, each supplied in 3 thicknesses (4, 8 and 12 mm thick),

The neck pad (XS, S and M or L, XL and XXL depending on the helmet size),

The ear cups and their adjustment pads (3 on each side + 2 extra on each side),

The comfort liner is adjustable in 4 areas with 3 possible thicknesses (N.B. When replacing the foam pieces, check that they are seated correctly). The neck pad is also supplied in 3 different thicknesses. The liner elements are fixed to the impact cap and shell with hook and loop tape, so no tools are needed.

N.B. Be careful not to break the polystyrene core of the neck pad during removal or reinstallation. The audio cables must run between the edge roll and the neck pad (see audio cable section).



## 3. Edge roll

---

Tools: None.

Dismantling duration: 20 seconds.

Mounting duration: 45 seconds.

The edge roll is replaceable. It is attached to the rim by means of press studs (3 on each side) and adjusts to fit the shell by means of two fastening pins. No tools are needed for its removal and reinstallation.

When removing the edge roll, it is best to take out the ear cups and the neck pad first. Then detach the 6 press studs and remove the 2 pins. When removing the first pin, it is important to twist the edge roll then slide the pin along its slot. The second pin will then come out easily on its own.

To reinstall the edge roll, engage the pins one after the other in the slots, then fasten the press studs.





## 4. Inner visor:

---

Tools: None.

Removal time: 15 seconds.

Reinstallation time: 30 seconds.

The inner visor is attached to its rotation system by means of clips.

Move the visor to the lowered position. Important: the direction of removal of the inner visor is perpendicular to the 2 rivets of the visor attachments.

To reinstall it, check that the control levers of the inner visor are in the lowered position.

Engage the visor so that the clips will go into their housings correctly. Clip in by pressing on the ends of the visor.

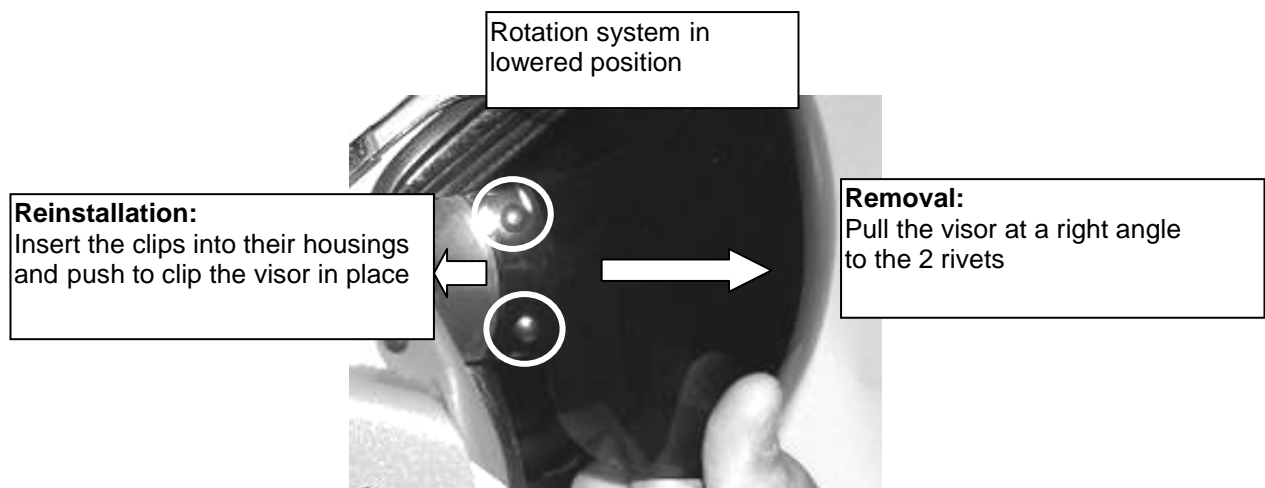

## 5. Outer visor:

- Tools: 2 mm hexagonal screwdriver, Philips screwdriver.  
Removal time: 2 minutes.  
Reinstallation time: 2 minutes.

Remove the hard cover (see section 6).

Unscrew the 2 small BLACK M2, 2x6 TF POZIDRIV screws at the front.

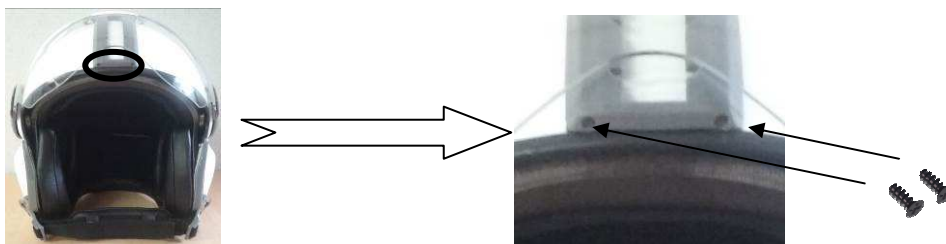

Lower the visor so that you can remove the outer visor guide assembly from the rail.

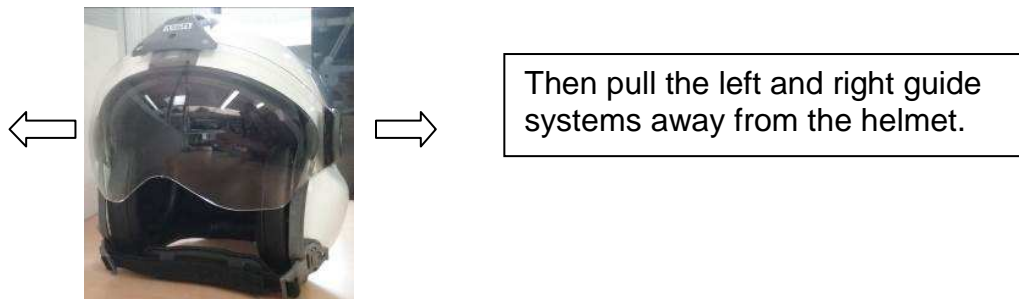

For reassembly, perform the same operations in reverse.

### Warning

When you are reinstalling the hard cover, check that the pin is correctly positioned in the base.

Tighten the STAINLESS STEEL M3X8 TF HC screws on the right and left.

## 6. NVG hard cover:

---

Tools: 2 mm hex screwdriver

Removal time: 2 minutes.

Reinstallation time: 3 minutes.

Unscrew the 2 STAINLESS STEEL M3 T.FR.HC F17 screws on the left and right of the helmet; do not take off the wing knobs for controlling the inner visor. Then lift the hard cover from the front in order to release the rear attachment.

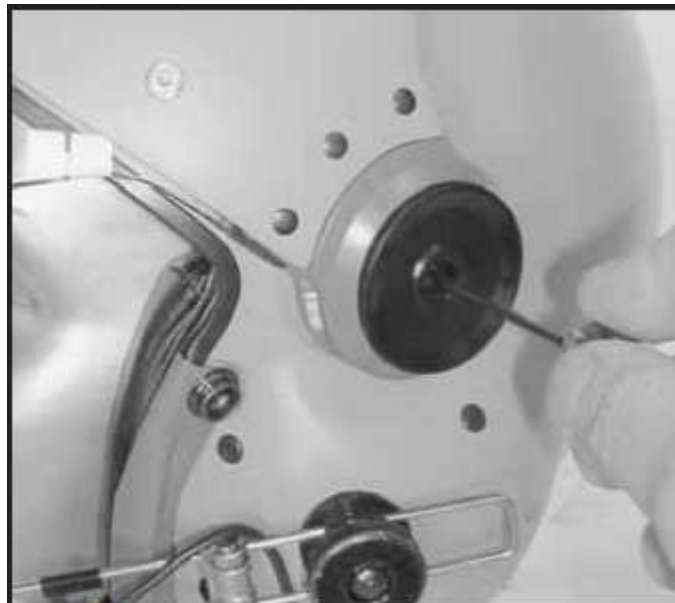

For reassembly, perform the same operations in reverse.

### **Warning**

When you are reinstalling the hard cover, check that the pin is correctly positioned in the base.

Tighten the STAINLESS STEEL M3 T.FR.HC F17 screws on the right and left.

## 7. Audio cable:

Tools: Philips screwdriver.  
Removal time: 5 minutes.  
Reinstallation time: 5 minutes.

For this operation it is first necessary to remove the edge roll in order to access the cable protection system.

- Remove the right ear cup,
- Remove the left ear cup,
- Remove the neck pad (make sure you do not break the piece of polystyrene inside it),
- Put the ear cups inside the helmet,
- Remove the edge roll (see section 4),
- Unfasten the cable bushing from the connection circuit.

Unscrew the 2 screws of the cable protector and remove it



Carefully unplug the link cable to the Lz/Hz microphone switching box.

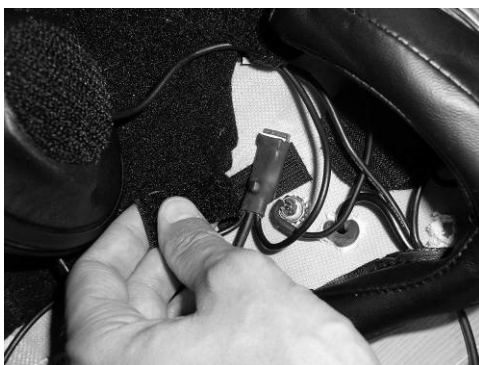

For reassembly, perform the same operations in reverse.

**Warning:** connect the JST plug on the link cable to the switching box on the circuit, in the socket labelled "MIKE".

## 8. Audio cable:

Tools: None.

Dismantling duration: 15 seconds.

Mounting duration: 30 seconds.

To remove the standard microphone cover (foam and attachment ring):

- Pull off the plastic ring (for the winchman's cover, pull off the cover itself).

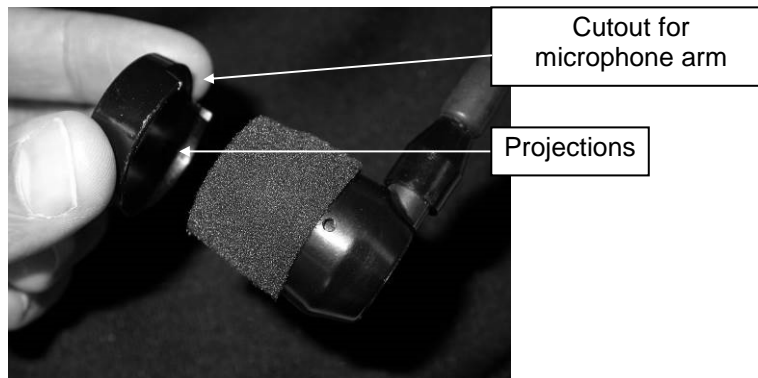

- Remove the protective foam from the unit.



- Then pull off the microphone unit to separate it from its base.



To reinstall it, engage the unit in its mount, making sure the foolproofing notches are the correct way round. Put on the cover followed by the ring, making sure the cutout for the microphone arm and the 2 projections for attachment to the unit are in the right place.

## 9. Combined microphone boom:

Tools: Philips screwdriver.  
Dismantling duration: 1 minute.  
Mounting duration: 1.5 minutes.

The left ear cup needs to be removed and the 3 press studs on the left side of the edge roll should be undone.

Unplug the microphone's JST connector.

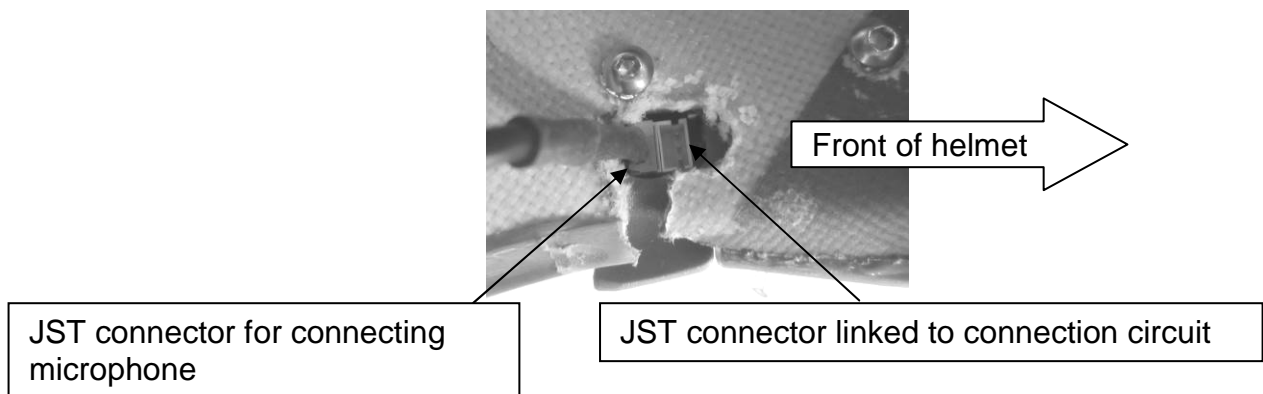

Remove the grommet from the shell.



Unscrew the central screw from the microphone boom.



Unscrew the microphone boom, making sure its components remain stacked in the correct order.



For reassembly, perform the same operations in reverse.

## 10. Microphone boom:

Tool: Philips screwdriver  
Dismantling duration: 1 minute.  
Mounting duration: 1 minute.



Perform the operations described in section 10 up to the flat metal washer.

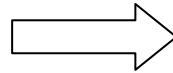

Unscrew the Philips screw

Remove the anti-rotation washer

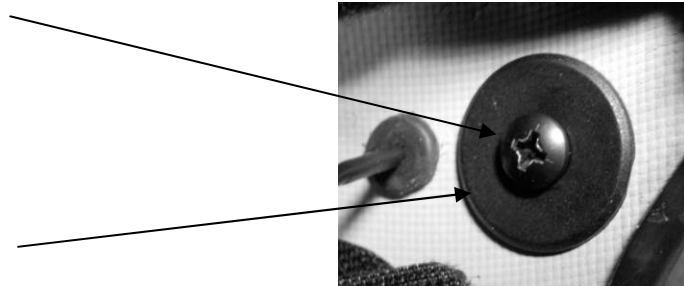

Inside the helmet



Outside the helmet

For reassembly, perform the same operations in reverse.

## 11. Removing the complete microphone:

Tool: None

Dismantling duration: 2 minutes.

Mounting duration: 2 minutes.

Remove the grommet from the shell  
(push it out from inside)

Inside



Outside



Inside the helmet, remove the left earphone  
Remove the inner liner by pulling the hook  
and loop tape tab



Unplug  
the 2 JST connectors

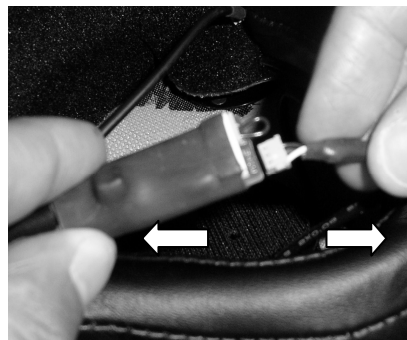

From the outside of the helmet,  
pull out the microphone cable.



See section 9 for removing the outside part of the microphone  
boom and the microphone

For reassembly, perform the same operations in reverse.



## 12. Earphones and hygiene parts of the ear cups:

Tools: 5.5 mm (box or flat) spanner  
Dismantling duration: 3 minutes.  
Mounting duration: 4 minutes.

To remove the earphones, take out the ear cups.

For each ear cup:

Remove the fabric seal.



Remove the 2 acoustic foam pieces



Pull the earphone cable away for easier access.



Unscrew the 2 nuts from the terminals.  
(Keep the nuts, etc.)

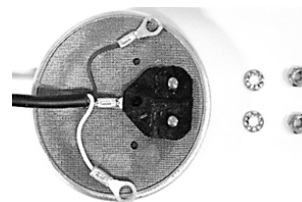

Remove the 3 connectors.

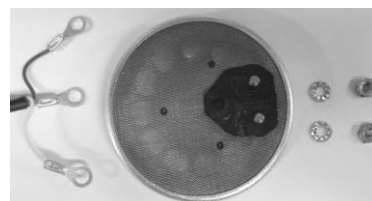

To reassemble, proceed in the reverse order.

## GENERAL INFORMATION

This section concerns the tests and inspections required to determine the condition of any units withdrawn from service. Dispose of any defective parts. All defective parts should be disposed of and replaced with new parts from MSA only. All tests should be carried out on clean parts (see section on cleaning).

### Inspection, testing and maintenance table:

<b>Basic checks*</b>	<b>Pre-flight</b>
Visors cleanliness and operation	yes
Presence and secure attachment of comfort elements (comfort liner, neck pad, edge roll)	yes
Condition of chinstrap and attachment points, operation of buckle	yes
Communication system test	yes
Attachment of hard cover	yes
Shell and hard cover (no cracks, no dents, aramid and carbon not visible, screws and inserts in their housings)	yes
General condition of helmet	yes
<b>Periodic checks*</b>	<b>Frequency</b>
Shell condition: particularly adhesion of chinstrap mounts, slight impacts due to normal use	3 months
Condition of impact cap and rim: in particular adhesion of impact cap to rim	3 months
Attachment of impact cap to shell	3 months
Secure attachment and operation of visors on their bases, communication system, cable protector	3 months
Condition and operation of visors and their attachment system	3 months
Condition of comfort liner pads	3 months
Condition of inner liner elements and ear cups	3 months
Condition of chinstrap and fastening buckle	3 months
Operation of chinstrap locking system	3 months
Operation of communication system (with inspection of cable condition)	3 months
Check that all screws are tight	3 months
Check the play of moving sub-assemblies during operation	3 months
Cleaning (in accordance with the instructions given in the user manual)	3 months
<b>Recommended replacement of main parts*</b>	<b>Frequency</b>
Inner visor	5 years
Outer visor	5 years
Edge roll	2 years
Comfort liner and neck pad	2 years
Chinstrap attachment assembly	2 years
Chinstrap	2 years
Comfort ear seals	2 years
LH 250 chinstrap assembly	2 years
Impact cap	15 years
Shell	15 years

\*: based on normal use of 200 hours per year and depending on the condition of the part.

## MANDATORY INSPECTIONS AND REPLACEMENT CRITERIA

This section explains the mandatory action to be taken and the inspections necessary when a helmet has suffered an impact OR when maintenance reveals damage caused by an impact.  
See criteria appendices.

The mandatory action and necessary inspections are explained in the table below.

ACTION TO BE TAKEN	Condition
<p>The helmet shell is designed to protect against a <b>single impact</b>.</p> <ul style="list-style-type: none"> <li>The integrity of the shell is considered to have been compromised after an impact.</li> <li>The shell of a helmet that has suffered an impact must be destroyed and replaced.</li> </ul>	<p><b>Impact:</b></p> <p><b>IMPACT CONFIRMED</b></p>
<p><b>Mandatory inspection</b></p> <p>Where damage caused by the impact is found. The helmet must be inspected to check for</p> <ul style="list-style-type: none"> <li>Dents, cracking or deformation of the composite fibres in the shell or hard cover;</li> <li>Damage to the composite shell consisting of composite fibres that have been cut or shredded;</li> <li>Removal of the outer coating leading to damage to the gel coat layer and exposure of the composite fibres;</li> <li>Movement of the impact cap;</li> <li>Damage to the visors and the visor movement mechanisms;</li> <li>Damage to the chinstraps at the chinstrap anchor points and the fastening buckle;</li> <li>The inspection must be recorded on the equipment monitoring sheet.</li> </ul> <p>If the inspection confirms an impact, the shell and the impact cap must be replaced.</p>	<p><b>Suspected impact:</b></p> <p><b>Mandatory inspections if an impact is suspected</b></p>

### User and maintenance workshop

All helmet users and maintenance units are responsible for reporting known or suspected impacts and damage to helmets.

MSA will not be held responsible for failure to remove from service a shell that has been damaged or has suffered an impact.

**Only MSA distributor is authorized to remove the impact cap. In case of doubt about the integrity of the impact cap or the shell, contact your MSA distributor.**

## APPENDICES: Replacement criteria

### - LH 250 PM and GM shell and fittings

Sub-elements	Defects	Criteria	Action
Shell	Cracks and/or scratches	Aramid fibres damaged*	<b>Replace</b>
		Aramid fibres not damaged*	Nothing to report
	Impacts	Height of fall > 1 m	<b>Replace</b>
		Height of fall < 1 m	Nothing to report
Rail	Riveting	Defective	Replace
	Attachment	Coming apart	Replace
	Breakage	Defective	Replace
	Wear	Defective	Replace
Chinstrap mount	Riveting	Defective	Replace
	Attachment	Coming apart	Replace
	Breakage	Defective	Replace
	Wear	Defective	Replace
Edge seals	Attachment	Coming apart	Rebond with glue

Cosmetic defects (paint scratches, etc.)  
do **not require replacement of the shell.**

## Paint scratch



Scratch to paint and gel coat but no damage to aramid  
or carbon.

## ***Defect where the aramid and/or carbon are showing***

The appearance of aramid and/or carbon filaments means



Deep scratch affecting the aramid (yellow) or carbon (black) in the  
shell.

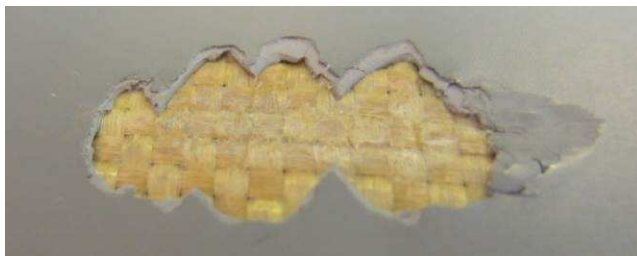

Hole following an impact revealing the aramid (yellow) or carbon (black) in the  
shell.

## **Cracks with or without replacement of the shell**

If a helmet has one or more paint cracks on the outside and white marks (delamination of the aramid) on the inside, the **shell must be replaced**.



**Warning:** cracked paint can signal an impact or that the shell has been tightly squeezed; in this case the impact cap must be removed to check the condition of the aramid inside the shell.

## **Impacts**

If a helmet has one or more traces of impacts on the outside and white marks (delamination of the aramid) on the inside, the **shell must be replaced**.

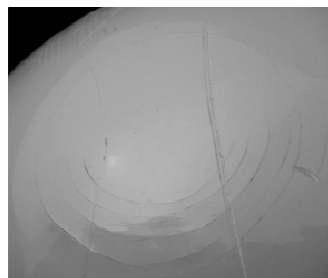

Specific traces of an impact inside the shell: concentric white lines matching the cracks on the outside.

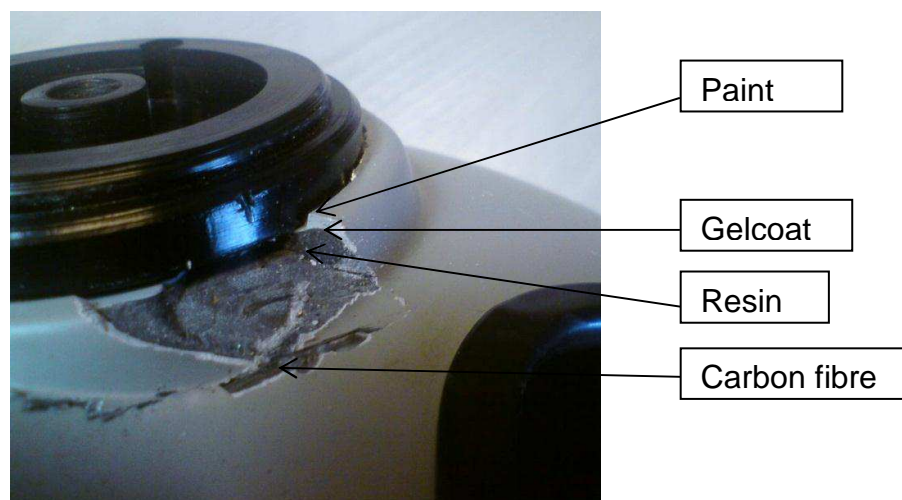

The appearance of carbon filaments in the area where the visor mechanism is located means that the **shell must be replaced**.

## Complete PM and GM aviation impact caps

The impact cap/rim assembly must be replaced in the following cases

- deformed impact cap,
- impact cap unstuck from its rim,
- rim showing white marks.

Sub-elements	Defects	Criteria	Action
Rim	White mark on the carbon	Part close to leather + rayon**	Nothing to report
	Breakage	Defective	Replace
	Weld	Crack	Replace
	Attachment	Coming apart	Replace
Impact cap Inner liner	Deformation	Defective	Replace
	Breakage	Defective	Replace
	Attachment	Coming apart	Replace
Press stud	Crimping	Excessive play or missing	Replace

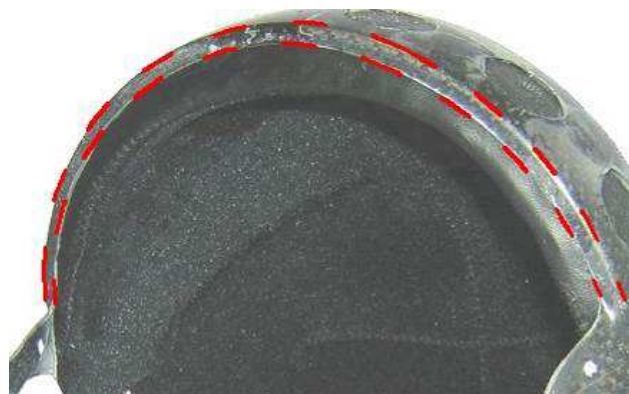

part near leather + rayon

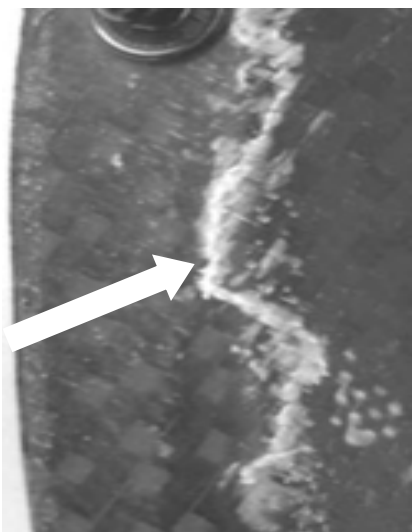

Examples of white marks on the carbon rim of the impact cap.

## PM and GM inner visor assembly

Zones on inner visor:

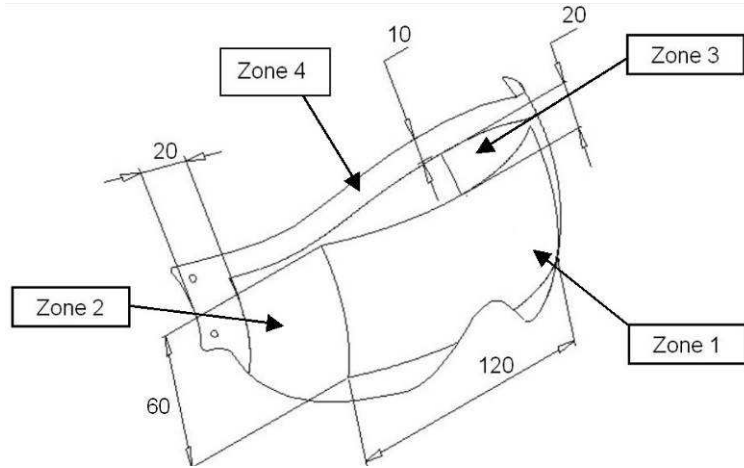

## PM and GM outer visor assembly

Zones on outer visor:

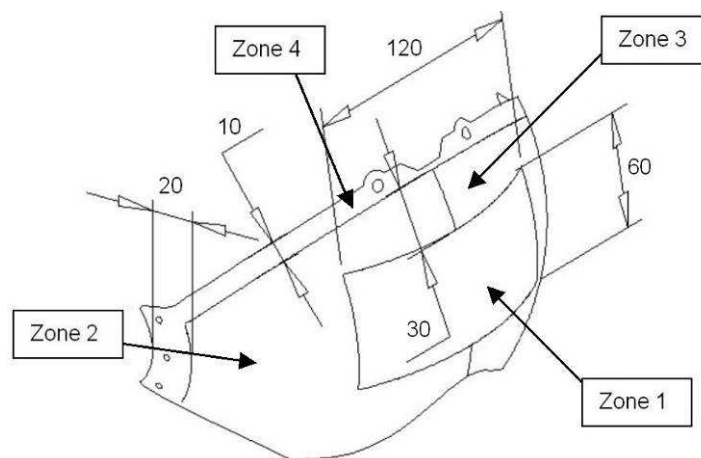



Zone	Defects	Criteria	Action
Zone 1	Spots of paint $\varnothing$ 0.1 mm	Quantity > 3	Replace part
	Spots of paint $\varnothing$ > 0.1 mm	Quantity = 0	Replace part
	Scratches: length < 5 mm, depth < 0.05 mm	Quantity > 8	Replace part
Zones 2 and 3	Spots of paint 0.1 mm < $\varnothing$ < 0.2 mm or Black spots 0.1 mm < $\varnothing$ < 0.2 mm or Scratches: length < 5 mm; depth < 0.05 mm	Quantity > 5	Replace part
		Quantity = 2	Replace part
		Quantity > 16	Replace part
Zone 4	All	None	
Sub-elements	Defects	Criteria	Action
Velcro hooks	Coming apart	Minor	Nothing to report
	Coming apart	Major	Replace part
Lateral interfaces	Riveting	Excessive play or missing	Replace part
Lateral interface	Breakage	Defective	Replace part
Visor inserts	Coming loose	Defective	Replace part
Outer visor guide	Operation of hooks	Spring stuck or lost	Replace sub-assembly
	Slider	Defective	Replace sub-assembly

### Inner visor rotation tests

It must be possible to rotate the visor using either of the knobs with one hand (thumb/index finger).

**N.B.:** The two screws holding in place the inner visor controls should be tightened 1/8 turn from when the tightening stress increases, with the 2 mm hex screwdriver.

### Outer visor locking tests

Starting from the raised position, the visor is locked and unlocked in the lowered positions

## Chinstrap assembly

Sub-elements	Defects	Criteria	Action
Locking clip	Play	Free	Replace chinstrap assembly or locking clip
Chinstrap lever or scale	Crack	Defective	Replace chinstrap assembly or chinstrap attachment
Strap	Stitching	Defective	Replace chinstrap assembly or strap
Screw	Missing	Defective	Replace chinstrap assembly or screw
Strap	Wear	Defective	Replace chinstrap assembly or strap
Keeper	Wear	Defective	Replace chinstrap assembly or keeper