



GENERAL MONITORS

Model IR4000M

Multi-Point Monitor



The information and technical data disclosed in this document may be used and disseminated only for the purposes and to the extent specifically authorized in writing by General Monitors.

Instruction Manual

12-09

General Monitors reserves the right to change published specifications and designs without prior notice.

**Part No.
Revision**

**MANIR4000M-EU
C/12-09**



General Monitors Model IR4000

E C Declaration of Conformity in accordance with EC & ATEX Directives

We at General Monitors Ireland Ltd., Ballybrit Business Park, Galway, Republic of Ireland, hereby declare that the equipment described below, both in its basic design and construction, and in the version or versions marketed by us, conforms to the relevant safety and health related requirements of the appropriate EC Directives, only as follows:

- a) Conform to the protection requirements of EMC Directive 2004/108/EC
Number C70731K1 (Dated 8/08) by compatible Electronics, 19131EI Toro Road, Lake Forest, CA 92676

Relevant Standards:
EN 55011
EN 50270

- b) Sira Certification Service, notified body number 0518 in accordance with Article 9 of Directive 94/9/EC of 23 March 1994, certifies that this equipment has been found to comply with the Essential Health and Safety Requirements relating to the design and construction of equipment intended for use in potentially explosive atmospheres given in Annex II to the Directive. Certificate No. 08ATEX1095X.

Relevant Standards:
EN 60079-0:2006 EN 61241-0:2006 IEC 60079-0:2007 (used for guidance on marketing)
EN 60079-1:2007 EN 61421-1:2004

This declaration shall cease to be valid if modifications are made to the equipment without our approval.

PRODUCT: IR4000S/M Single and Multi Point Monitor

It is ensured through internal measures and our ISO9001: 2000 certifications that series production units conform at all times to the requirements of these current EC Directives and relevant standards.

Note: The Following Information applies to ATEX.

This equipment has not been assured for use as a safety related device under the terms of Directive 94/9/EC EHSR 1.5
General Monitors Ireland Ltd. in order to comply with ATEX, will provide this Instruction Manual in a European Language required to operate the product upon request. Should this be necessary, General Monitors Ireland Ltd. should be notified of this request to allow adequate time to process the request.

ATEX Certificate Markings.



II 2 G D SIRA 07ATEX1253



Exd IIB+H₂ T5 Gb (Ta -60° C to +75° C)
Ex t IIB T100° C Db

Responsible Person:

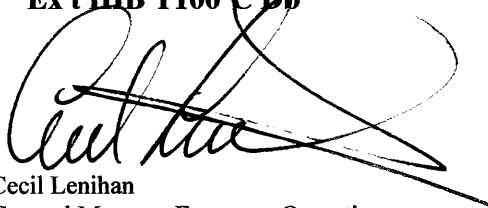
Cecil Lenihan
General Manager European Operations

Date: 07-12-09

The signatory acts on behalf of company management, and with full power of attorney

Table of Contents

TABLE OF FIGURES.....	IV
QUICK START GUIDE.....	1
Mounting.....	1
Cabling and Wiring.....	2
Applying Power.....	4
1 INTRODUCTION.....	5
1.1 Protection for Life.....	5
1.2 Special Cautions and Warnings.....	5
1.3 Installation, Operation, and Maintenance.....	5
2 PRODUCT DESCRIPTION.....	6
2.1 Features and Benefits.....	7
2.2 System Configurations.....	7
3 INSTALLATION.....	9
3.1 Unpacking the Equipment.....	9
3.2 Mounting.....	10
3.3 Cabling and Wiring.....	12
3.4 Applying Power and Starting Operation.....	18
4 OPERATION AND CONFIGURATION.....	20
4.1 Overview.....	20
4.2 Resetting the Relays (rSt).....	22
4.3 Viewing the Gas Concentration for Selected IR400s.....	22
4.4 Entering Gas Check Mode.....	23
4.5 Zeroing an IR400.....	24
4.6 Calibrating an IR400.....	24
4.7 Setup.....	25
5 MAINTENANCE.....	29
5.1 Developing a Maintenance Schedule.....	29
5.2 Gas Checks, Zeroing and Recalibration.....	29
5.3 Lubricating Threads and Seals.....	29
5.4 Replacing an Attached Detector.....	29
5.5 Maintaining the X/P Integrity.....	30
5.6 Storage.....	30
6 TROUBLESHOOTING.....	31
7 MODBUS INTERFACE.....	34
8 CUSTOMER SUPPORT.....	35



9 APPENDIX..... 36

9.1 Warranty..... 36

9.2 Specifications 36

MAXIMUM DISTANCE FOR ANALOG OUTPUT (500 OHMS MAX):..... 38

9.3 Modbus Interface 39

9.4 Ordering Information 40

Table of Figures

Figure 1: Sample IR400 and IR4000M system 1

Figure 2: IR4000M Outline and Mounting Dimensions, in inches [mm] 2

Figure 3: IR4000M Terminal Block Connections..... 3

Figure 4: IR4000M Display 6

Figure 5: Sample IR4000M Installation 8

Figure 6: IR4000M with IR400 Mounting Dimensions in inches [mm]..... 11

Figure 7: IR4000M Outline and Mounting Dimensions in inches [mm] 12

Figure 8: IR4000M Terminal Block Connections..... 14

Figure 9: Wiring from IR4000M to Control Equipment 15

Figure 10: Push Terminal Block Operation 16

Figure 11: Screw Type Terminal Block Operation..... 16

Figure 12: Relay Protection for DC and AC Loads..... 17

Figure 13: Front Panel LEDs 20

Figure 14: IR4000M Menu Structure 21

Figure 15: Simple RS-485 Termination 39

Figure 16: RS-485 Termination with Fail-Safe Biasing 40

Quick Start Guide

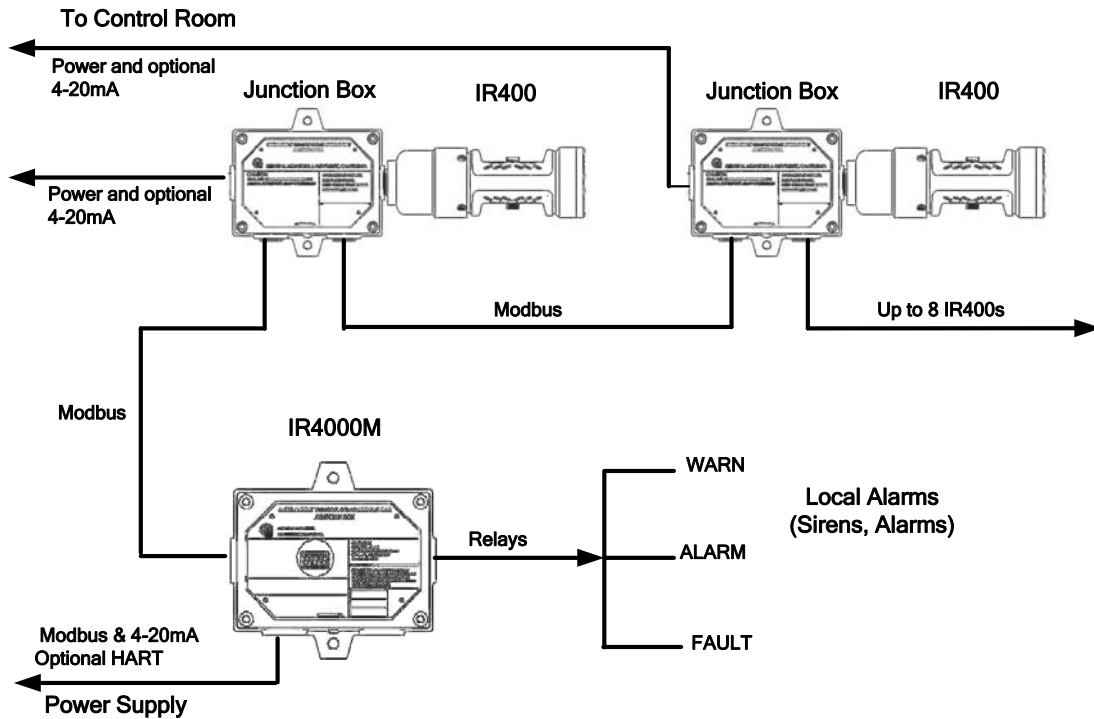

Figure 1: Sample IR400 and IR4000M system

Special tools:

- 5 mm Allen wrench for cover (included with unit)
- 0.1" flat-head screwdriver for wiring (included with unit)
- Adjustable wrench for conduit or cable gland connections (not included)

Mounting

Allow convenient access to the front panel display and magnet switch input.

Leave sufficient room to attach cabling. Keep cable run distances below specified limits.

Although the Model IR4000M is RFI-resistant, where possible mount it away from heavy power cabling, radio transmitters, or similar equipment.

Where possible locate the IR4000M away from excessive heat and vibration and as free as possible from wind, dust, water, and direct sunlight.

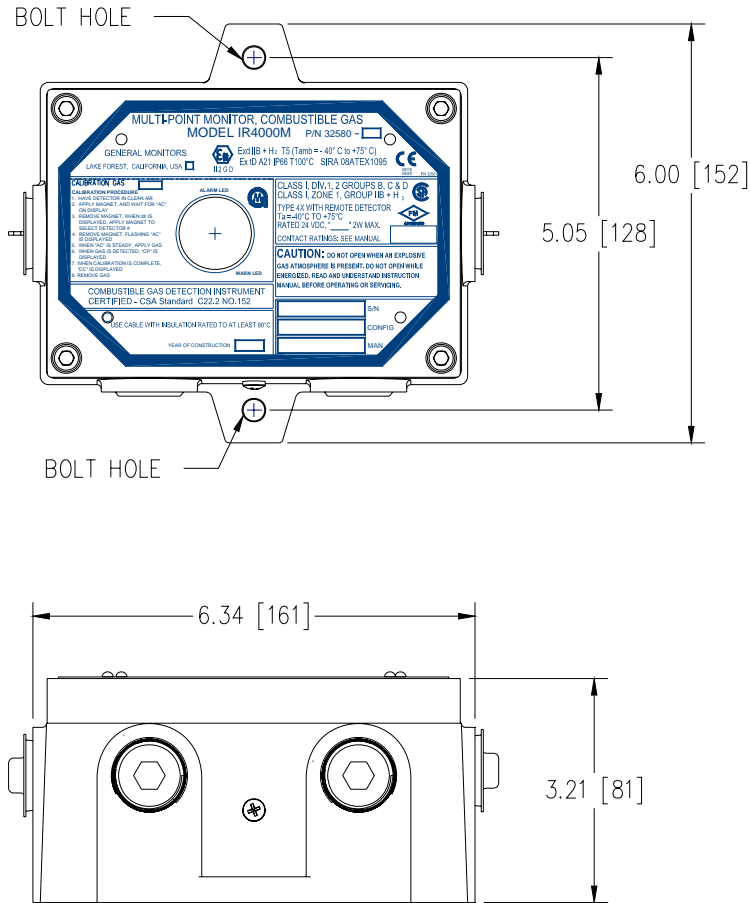

Figure 2: IR4000M Outline and Mounting Dimensions, in inches [mm]

To mount an IR4000M:

1. Seal each conduit entry once the wiring through that conduit is completed.
2. Some lubricant/sealant is pre-applied at the factory. Apply the additional supplied thread lubricant/sealant to all conduit entries, as needed to prevent binding.
3. Bolt the IR4000M enclosure to a wall using the two bolt holes on the enclosure.

Cabling and Wiring



WARNING: Seal conduit entries per Class I hazardous location requirements. Under **NO** circumstances should equipment be connected or disconnected when under power. Equipment damaged in this manner is not covered under warranty.



CAUTION: Do not use a sealant that contains acetic acid. Use precautions to avoid equipment damage by static electricity.

The cable **armor** must be connected to **safety earth** in the safe area.

The cable screen (drain wire) must be connected to an instrument earth in the safe area.

Three-wire shielded cable is recommended for power and signal connections.

The push terminal blocks accept 14 AWG to 20 AWG stranded or solid wire. Screw terminal blocks accept 12 AWG to 18 AWG wire.

Power to the IR4000M must remain OFF until all wiring is completed and the start-up readiness checklist has been verified. Wire installation order:

- Common (COM or 0 V) and Field Ground (FG) wires
- Modbus (MOD), Analog (mA), CAL and relay wires (RLY, ALARM, WARN, and FAULT)
- 24 VDC power

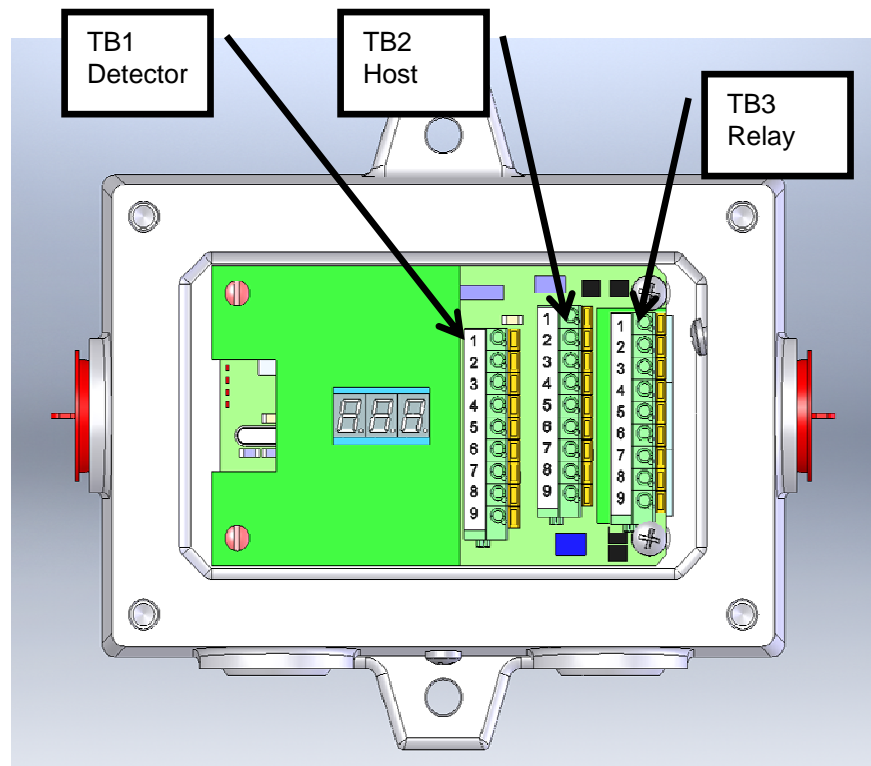

IR400 Detector Terminal	
TB1	SIGNAL
1	4-20mA IN *
2	CAL IN *
3	COMMON
4	FGND
5	MOD+
6	MOD-
7	COMMON
8	+24V
9	+24V

Host Terminal	
TB2	SIGNAL
1	4-20mA OUT
2	MOD1 -
3	MOD1 +
4	MOD2 -
5	MOD2 +
6	NOT USED
7	RELAY RESET
8	COMMON
9	+24V IN

Relay Terminal		
TB3	DE-ENERGIZED	ENERGIZED
1	ALARM-NC	ALARM-NO
2	ALARM-C	ALARM-C
3	ALARM-NO	ALARM-NC
4	WARN-NC	WARN-NO
5	WARN-C	WARN-C
6	WARN-NO	WARN-NC
7	FAULT-NO	
8	FAULT-C	
9	FAULT-NC	

Figure 3: IR4000M Terminal Block Connections

* These connections are not required. If only one IR400 is mounted directly to the IR4000M, these connections can be made to keep the wires out of the way. Do not connect signals from more than one IR400 here.

Applying Power

Before applying power for the first time, check the following:

- Verify that the junction box lid is securely installed, unless the area has been declassified.
- Inhibit any external devices, such as Trip Amplifiers, PLC devices or DCS systems.
- Verify that the power supply is connected properly. The IR4000M and IR400 are powered by +24 VDC (20 to 36 VDC voltage range). The IR4000M will display a fault code of bF6 if the power supply voltage is below 18.5 VDC.
- Power-up Sequence
 1. 000 and Alarm Indicator on for 1 second
 2. All display elements (8.8.8.) and both Alarm and Warn Indicators on for 2 seconds
 3. Software revision on for 2 seconds (example: r 3)
 4. bSU (base Start Up) for 12 seconds
 5. SU (IR400 Start Up) for 1 minute, 45 seconds
 6. Gas concentration in % LEL

Please consult the remainder of the manual for more information on calibration, operation, and other product features.

NOTE: The IR4000M is only compatible with the Model IR400 point IR detector. General Monitors' Model IR2100 is not compatible with the IR4000M.

1.0 Introduction

1.1 Protection for Life

General Monitors' mission is to benefit society by providing solutions through industry-leading safety products, services and systems that save lives and protect capital resources from the dangers of hazardous flames, gases and vapors.

The safety products you have purchased should be handled carefully and installed, calibrated and maintained in accordance with this instruction manual. Remember, these products are for your safety.

1.2 Special Cautions and Warnings

This instruction manual includes numerous cautions and warnings that are included to prevent injury to personnel and prevent damage to equipment.



WARNING: TOXIC, COMBUSTIBLE, AND FLAMMABLE GASES AND VAPORS ARE VERY DANGEROUS. USE EXTREME CAUTION WHEN THESE HAZARDS ARE PRESENT.

1.3 Installation, Operation, and Maintenance

Before power up, verify wiring, terminal connections and stability of mounting for all integral safety equipment.

Proper system operation should be verified by performing a full, functional test of all component devices of the safety system, ensuring that the proper levels of alarming occur. Fault/malfunction circuit operation should be verified.

Periodic testing/calibrating should be performed per the manufacturer's recommendations and instructions.

When testing produces results outside of the manufacturer's specifications, re-calibration or repair/replacement of the suspect device(s) should be performed as necessary. Calibration intervals should be independently established through a documented procedure, including a calibration log maintained by plant personnel, or third party testing services.

NOTE: The Model IR4000M is easy to install; however, you should read and understand this manual before attempting to install or operate the device. It includes important safety information.

2.0 Product Description

The Model IR4000M Multi-Point Monitor is a display, relay module, and a data concentrator. It provides monitoring and control functions for up to eight connected Model IR400 point IR gas detectors, with a three-digit status display. The IR4000M is housed in an explosion-proof junction box enclosure that can be installed in hazardous locations adjacent to the detectors.



Figure 4: Model IR4000M

The highest current % LEL among all connected detectors is shown continuously during Normal operation. In addition, the IR4000M reads seven data items from each of the IR400s connected to it, at least once per second. To request the status and configuration data stored by the IR4000M, you can use an extensive set of menus that are navigated using a magnetic switch.

In addition, over 200 IR4000M and IR400 Modbus registers provide the greatest possible flexibility in reviewing current status data and settings, and configuring operating parameters. For example, the IR4000M can report % LEL data for all eight detectors with one command, which is useful in large multi-point systems.

Optional relays provide output for Warn, Alarm and Fault conditions occurring at each detector. Operating mode, Warn, and Alarm setpoints are user-selectable via a magnetically-activated switch. The relays are user-programmable as Latching or Non-Latching, normally De-Energized or normally Energized. Latching relays can be reset via a remote reset input or via the magnetic switch.

2.1 Features and Benefits

The Model IR4000M enhances the features and benefits of the IR400 in several important ways:

- The IR4000M's explosion-proof enclosure can be installed in hazardous locations, adjacent to IR400 detectors.
- Single digital status display mounted at eye level can connect to as many as eight remote IR400 detectors, providing ease of maintenance and accessibility.
- Onboard data concentrator can read status for up to 8 devices at once with one command, which is useful in large, multi-point systems.
- The IR4000M can calibrate, gas check and zero multiple IR400 devices based on a single command.

2.2 System Configurations

There are several alternate configurations for IR400 and IR4000M-based systems, which require different installation and cabling instructions:

IR4000M Systems. One or more IR4000M Monitors can be combined with IR400 units, in several ways:

- **Attached IR400/IR4000M Combination.** A single IR400 can attach directly to an IR4000M, with the IR4000M cabled to control room and alarm devices.
- **IR4000M Monitor System.** One to eight IR400 detectors can be attached to junction boxes and cabled to an IR4000M using the Modbus interface (see Figure 5). Analog, Modbus Channel 2, and power supply signals are forwarded from the IR400 detectors to the control room. (If the detectors are close to the IR4000M and its power supply, some can be connected to power and ground via the IR4000M.)

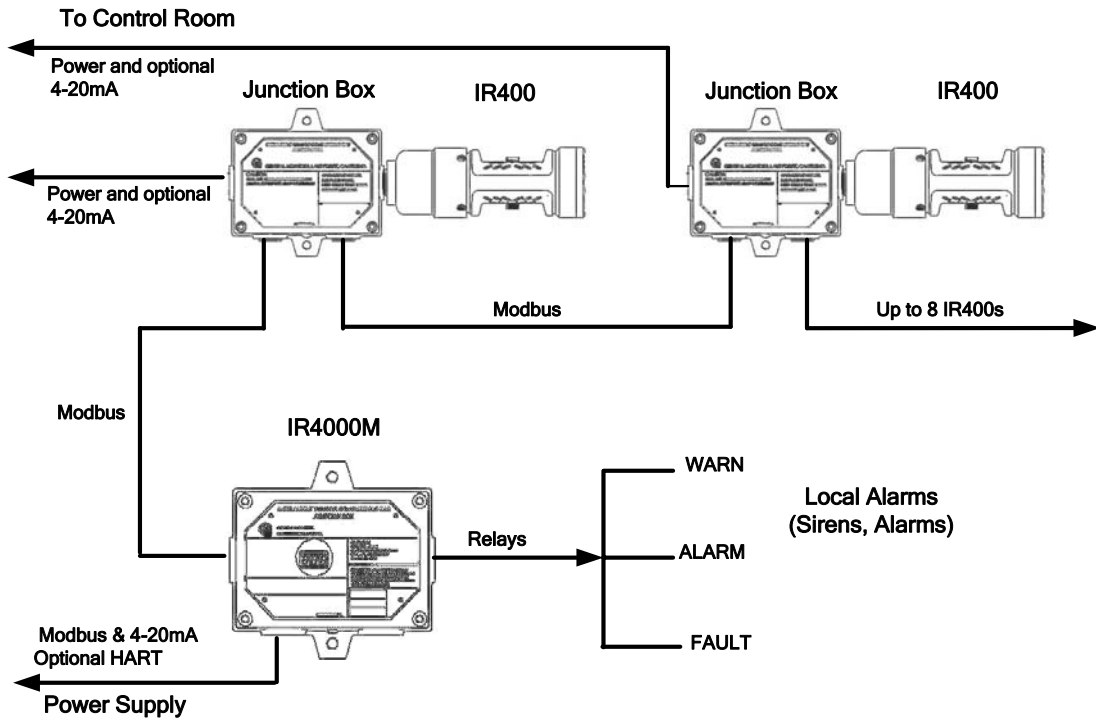

Figure 5: Sample IR4000M Installation

3.0 Installation



CAUTION: The IR4000M contains components that can be damaged by static electricity. Special care must be taken when wiring the system to ensure that only the connection points are touched.



CAUTION: Installation and Maintenance must be carried out by suitably skilled and competent personnel only.

Special tools:

- 5 mm Allen wrench for cover (included with unit)
- 0.1” flat-head screwdriver for wiring (included with unit)
- Adjustable wrench for conduit or cable gland connections (not included)

Installation Step	Refer to Section
1. Unpack the equipment and prepare for installation	3.1
2. Attach each IR400 to a junction box or an IR4000M	3.2
3. Mount the IR400 and IR4000M units in place. (Steps 3 and 4 can be swapped if it is easier to attach cabling before the units are mounted in place.)	3.2
4. Install cabling between the IR400, IR4000M units, and control room devices. The control room devices include Modbus, 4-20mA and a power supply	3.3
5. Power on the equipment	3.4
6. Gas check or calibrate the IR400 units	4.6

Table 1. IR400/IR4000M Installation Overview

3.1 Unpacking the Equipment

All equipment shipped by General Monitors is packaged in shock absorbing containers, which provide considerable protection against physical damage. The contents should be carefully removed and checked against the packing list.

If any damage has occurred or there is any discrepancy in the order, please notify General Monitors as soon as possible. All subsequent correspondence with General Monitors must specify the equipment part number and the serial number.

NOTE: Each Model IR4000M is completely tested at the factory. However, a system checkout is required upon initial start-up to ensure system integrity.

3.2 Mounting

Allow convenient access to the monitor. A magnetic switch behind the cover is the input for local configuration and calibration.

Leave sufficient room to attach cabling. Keep cable run distances below specified limits.

Although the Model IR4000M is RFI-resistant, where possible mount it away from heavy power cabling, radio transmitters, or similar equipment.

Locate the IR4000M away from concentrated sources of heat or light. They should be mounted in areas that are free from excessive vibration and as free as possible from wind, dust, water, and direct sunlight.

If an IR400 gas detector is connected directly to the IR4000M, the IR400 must be mounted horizontally to reduce the possibility of dirt and dust building up on the windows. The open slots of the gas passage must be straight up and down for the gas to rise up and through the unit. If the detector is installed with the metal section blocking the gas flow, it will slow down the detector's response. Refer to the IR400 instruction manual for additional recommendations.

If more than one IR400 detector will be connected to the IR4000M, it is important to realize that the IR4000M will display each detector with a detector number. This number should be marked on the IR400 when received from General Monitors and related to the Modbus ID for the detector. These numbers cannot easily be changed once the IR400 is installed.

Applying Sealants to Conduit Entries

Please keep the following warnings and cautions in mind when you install the IR400/IR4000M units, to make sure that the equipment maintains the appropriate seals for a Class I hazardous location.



WARNING: Each conduit run from an IR400 junction box or IR4000M housing within a hazardous location (and from a hazardous to a non-hazardous location) must be sealed so that gases, vapors, and/or flames cannot pass beyond the seal. The purpose of seals in a Class I hazardous location is to prevent the passage of gases, vapors, or flames from one electrical installation to another through the conduit system. For information on Class I location seals, see NEC Article 501-5.



WARNING: Unused cable entry holes in each IR400 junction box and IR4000M housing must be sealed with approved explosion-proof stopping plugs. Red caps supplied by General Monitors are for dust protection only, and must not be left on the unit when installed.



CAUTION: Acetic acid will cause damage to metal components, metal hardware, ceramic ICs, etc. If damage results from the use of a sealant that contains acetic acid (RTV silicone), the warranty will be void.



CAUTION: To prevent corrosion due to moisture or condensation, it is recommended that the conduit connected to the Model IR4000M housing be sealed or contain a drain loop.

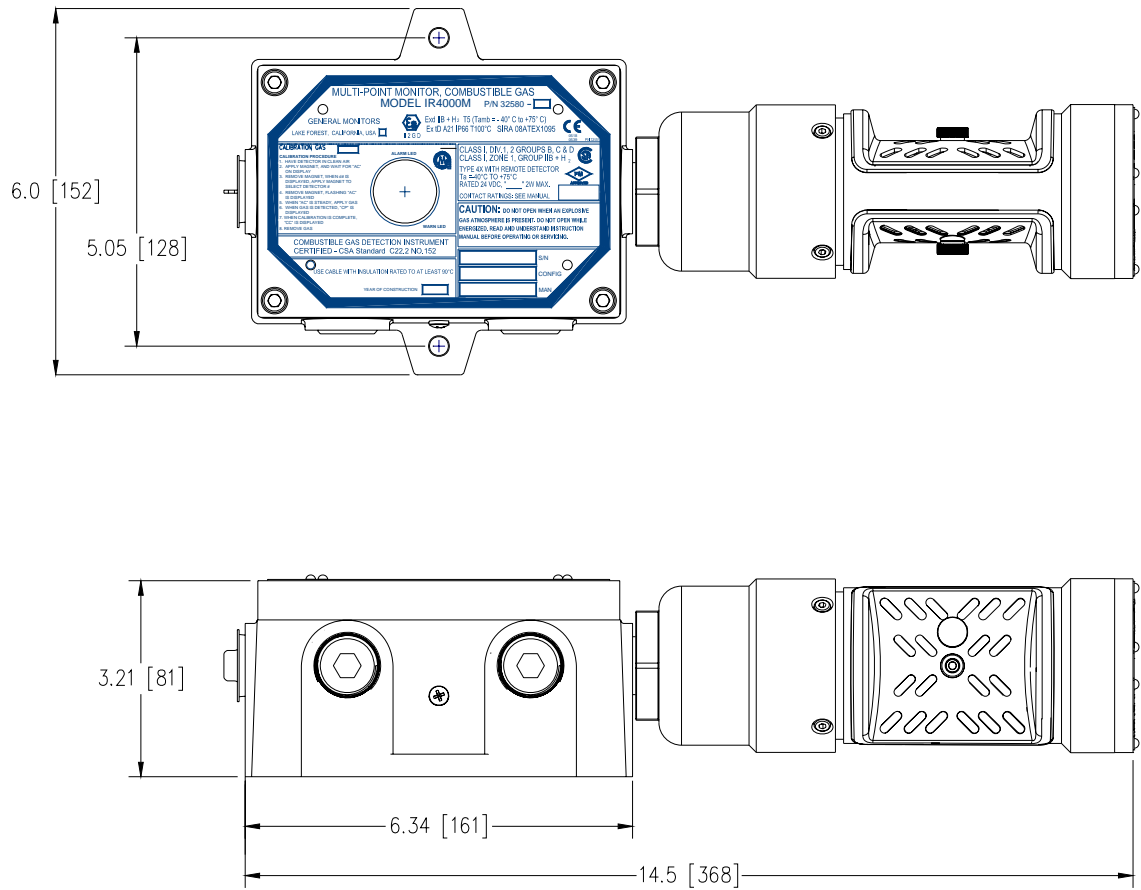

Figure 6: IR4000M with IR400 Mounting Dimensions in inches [mm]

This configuration is usually only applicable to one attached detector. For multiple detectors, each is connected to its own junction box.

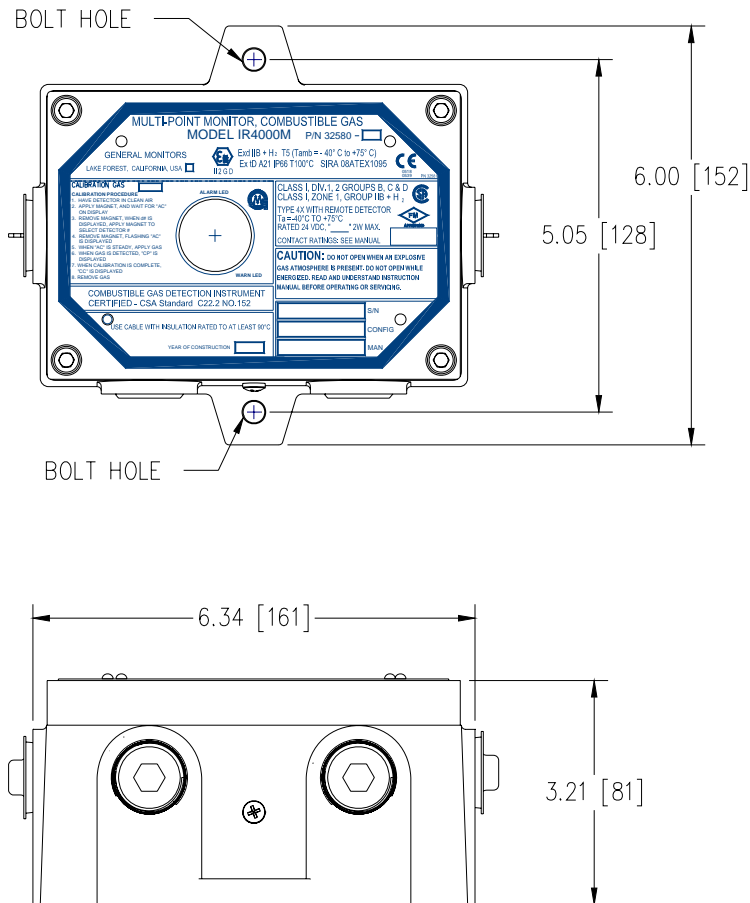

Figure 7: IR4000M Outline and Mounting Dimensions in inches [mm]

3.3 Cabling and Wiring

3.3.1 Cabling Safety Notices



CAUTION: The Model IR400 Point IR Gas Detector and Model IR4000M Multi-Point Monitor contain components that can be damaged by static electricity. Special care must be taken when wiring the system to ensure that only the connection points are touched.



WARNING: Under **NO** circumstances should equipment be connected or disconnected when under power. This is contrary to hazardous area regulations and may also lead to serious damage to the equipment. Equipment damaged in this manner is not covered under warranty.



WARNING: For safety reasons, Ground cabling must always be connected first, before other cabling is connected; +24 VDC power cabling should be connected last (and disconnected first). Power supply connections to the IR400 and IR4000M units must remain OFF until all wiring is completed and the start-up readiness checklist has been verified; refer to the manual for the power supply being used for instructions.

3.3.1.1 European Union (EU) Approved Cable Armor and Screens

Interconnecting cables must have an overall screen or screen and armor. Cables BS5308 Part 2, Type 2, or equivalent are suitable. Note that the terms 'screen' and 'shield' are equivalent for the purpose of this manual. The cable armor must be terminated in a suitable cable gland at the detector to ensure a positive electrical connection.

3.3.1.2 Cable Termination in Non-Hazardous Areas

The cable **armor** must be connected to **safety earth** in the safe area.

The cable **screen** (drain wire) must be connected to an **instrument earth** in the safe area.

The power supply **COMMON** must be connected to an **instrument earth** in the safe area.

The interconnecting cables should be segregated from power and other noisy cables. Avoid proximity to cables associated with radio transmitters, welders, switch mode power supplies, inverters, battery chargers, ignition systems, generators, switch gear, arc lights and other high frequency or high power switching process equipment.

In general, maintain separation of at least 1 meter between instrument and other cables. Greater separations are required where long parallel cable runs are unavoidable. Avoid running instrument cable trenches close to lightning conductor earthing pits.

Complete all cable insulation testing before connecting the cable at either end.

3.3.2 Wiring

Remove the cover from the IR4000M enclosure to access wiring connectors. The inside of the cover includes a label that lists the function of each connector location.



WARNING: For safety, ground cabling must always be connected first, before other cabling is connected. The 24 VDC power cabling should be connected last (and disconnected first). Power supply connections to the IR4000M must remain OFF until all wiring is completed and the start-up readiness checklist has been verified. Refer to the manual for the power supply being used for instructions.

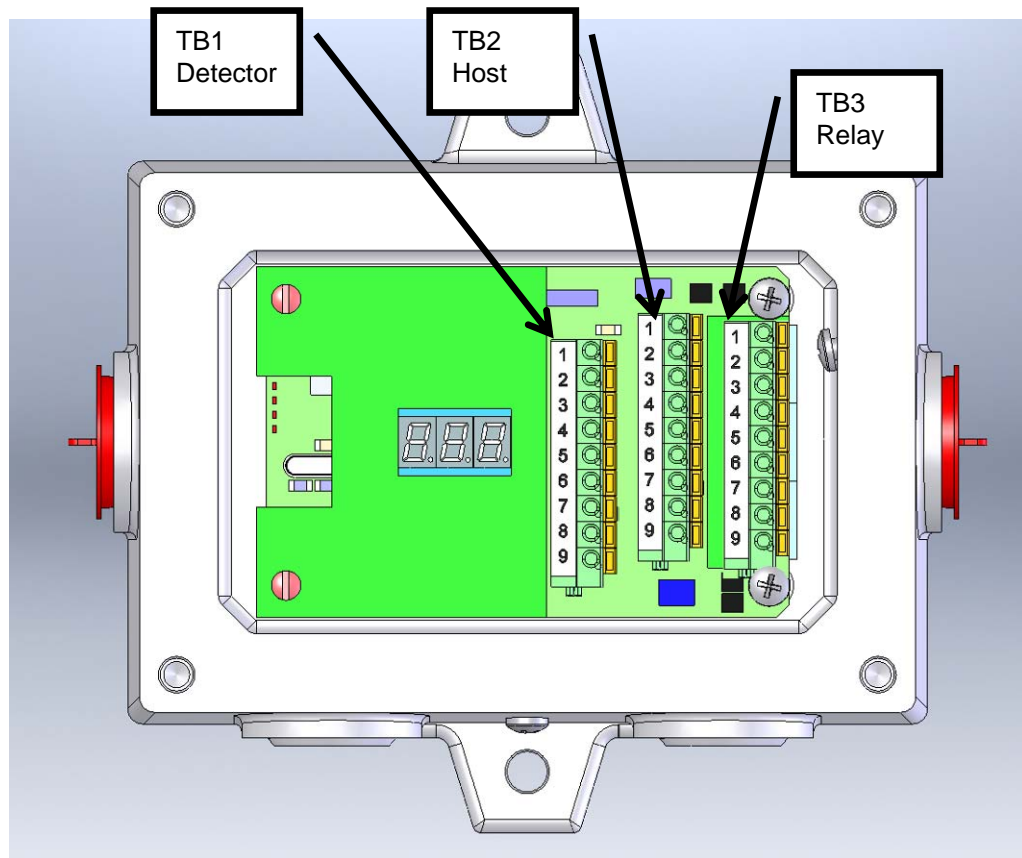

IR400 Detector Terminal	
TB1	SIGNAL
1	4-20mA IN *
2	CAL IN *
3	COMMON
4	FGND
5	MOD+
6	MOD-
7	COMMON
8	+24V
9	+24V

Host Terminal	
TB2	SIGNAL
1	4-20mA OUT
2	MOD1 -
3	MOD1 +
4	MOD2 -
5	MOD2 +
6	NOT USED
7	RELAY RESET
8	COMMON
9	+24V IN

Relay Terminal		
TB3	DE-ENERGIZED	ENERGIZED
1	ALARM-NC	ALARM-NO
2	ALARM-C	ALARM-C
3	ALARM-NO	ALARM-NC
4	WARN-NC	WARN-NO
5	WARN-C	WARN-C
6	WARN-NO	WARN-NC
7	FAULT-NO	
8	FAULT-C	
9	FAULT-NC	

Figure 8: IR4000M Terminal Block Connections

* These connections are not required. If only one IR400 is mounted directly to the IR4000M, these connections can be made to keep the wires out of the way. Do not connect signals from more than one IR400 here.

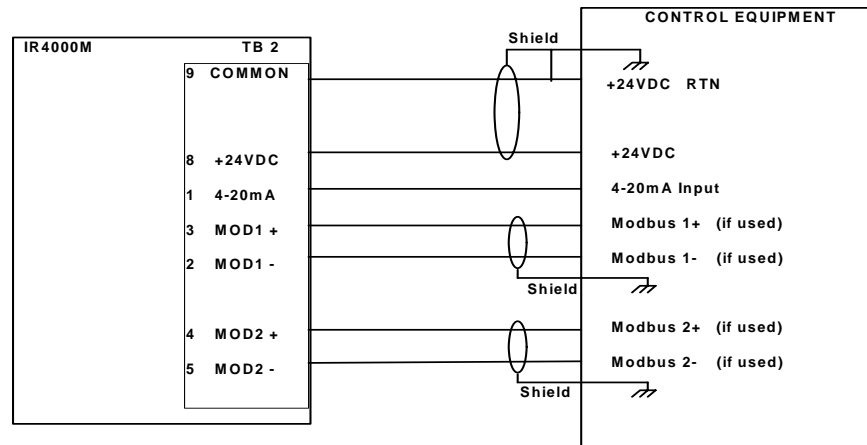

Figure 9: Wiring from IR4000M to Control Equipment



CAUTION: Contact with PCB components should be avoided to prevent damage by static electricity. All wire connections are made to the terminal blocks.

NOTE: It is recommended that a three-wire (red, black and white) shielded cable be used to make power and 4-20 mA signal connections to the Model IR4000M. The push terminal block accepts 14 AWG to 20 AWG and the screw terminal block accepts 12 AWG to 18 AWG stranded or solid wire. Each wire should be stripped before wiring the IR4000M.

To attach multiple IR400 detectors to a single IR4000M:

1. Plan the power, common, and field ground for each IR400 terminal block. The power can be wired from one junction box to the next as long as the total length of cable does not exceed the maximums in Section 9.2.4. Alternatively, the power wiring can be a “star” configuration from a central power supply.
2. The Mod+ and Mod- terminals on TB1 must connect to each IR400. This is usually done by connecting the IR4000M terminal to the junction box with the first IR400 attached, then continuing with the wiring out of this junction box and on to the next.
3. No other connections are required for the IR400 but the CAL (Brown) wire from each detector can be connected to a local Zero / Cal switch to allow calibration of a detector without requiring the operator being close to the IR4000M.

To Attach Wiring to an IR4000M Terminal Block:

1. Remove the IR4000M enclosure cover by loosening the four captive screws and lifting the cover straight up.
2. For push terminals (Figure 10), insert a screwdriver into the orange tab and press down, opening the terminal. For screw terminals (Figure 11), turn the screw counterclockwise to open.
3. Insert the stripped wire into the terminal and release the orange tab to clamp the wire in the terminal. GENTLY tug on the wire to make sure it is locked securely in place.

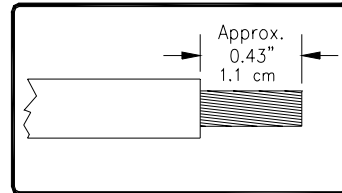
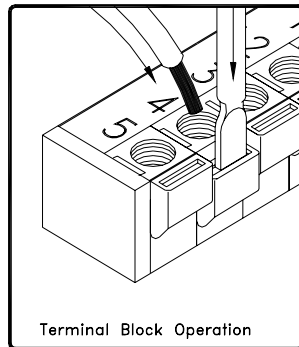

Figure 10: Push Terminal Block Operation

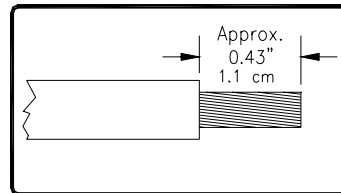
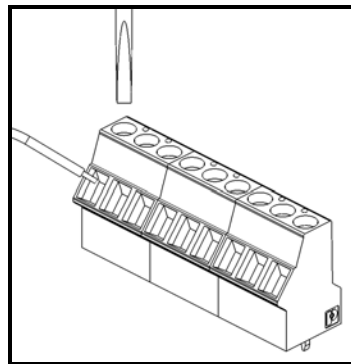

Figure 11: Screw Type Terminal Block Operation

4. When wiring is complete, replace the IR4000M cover and tighten the four captive screws.

Connecting Alarm Relay Devices to the TB3 Block

Terminal block TB3 contains the connections for the relay contacts for alarm equipment such as sirens; it is included on an optional circuit board module. The functioning of the Alarm and Warning relay connections varies depending on whether the relays are configured as Energized or De-Energized.

NOTE: The default IR4000M configuration menu setting for the Warning and Alarm relays is De-Energized. For further information, see relay configuration information in Section 4.7.2. The Fault relay is normally Energized. It will change state after power-up.

Use the following table as a guide for determining the Normally Open (NO) and the Normally Closed (NC) contacts for the Energized versus De-Energized setting:

Relay Type	TB3 position	De-Energized	Energized
Alarm	1	Normally Closed	Normally Open
	2	Common	Common
	3	Normally Open	Normally Closed
Warning	4	Normally Closed	Normally Open
	5	Common	Common
	6	Normally Open	Normally Closed
Fault	7		Normally Open
	8		Common
	9		Normally Closed

Table 2. TB3 Relay Contacts Energized/De-Energized Settings



WARNING: Relay contacts must be protected against transient and over-voltage conditions (see Figure 12).

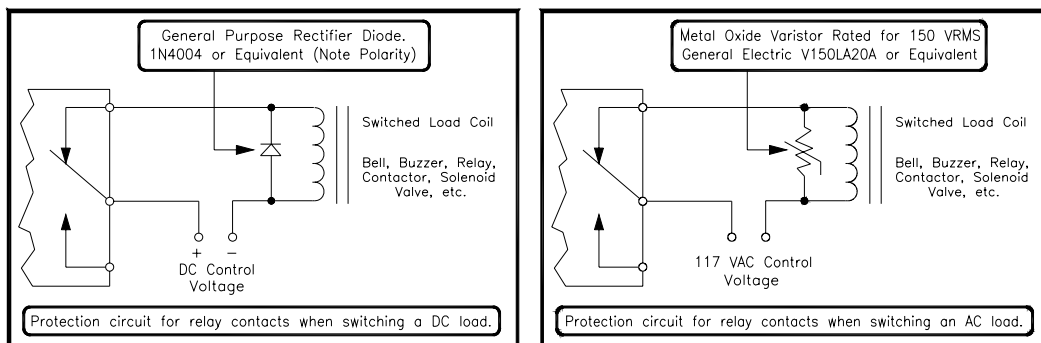

Figure 12: Relay Protection for DC and AC Loads

European Union (EU) Approved Applications: The ALARM relay contact ratings are 8 A, 30 V RMS/42.4 V peak or 8 A @ 30 VDC resistive max.

North American Approved Applications: The ALARM relay contact ratings are 8 A @ 250 VAC and 8 A @ 30 VDC resistive max.



3.4 Applying Power and Starting Operation

Once the mounting, cabling and alarm relay installation is complete, the IR400/IR4000M detection system is ready to begin the power-on sequence. Please review this section carefully before powering on your GM standalone detectors or your IR400/IR4000M.

3.4.1 Start-up Readiness Checklist

Prior to applying power to the system for the first time, check the following items for a stand-alone IR400 detector and for an IR4000M monitor system configuration.

NOTE: The +24 VDC wire(s) to the power supply (supplies) should be connected after the readiness checklist is verified, to protect the system from shorting. Since the IR400 and IR4000M are designed to monitor continuously for hydrocarbon gas leaks, they do not have power switches, in order to prevent accidental system shutdown.

1. Verify that all the signal wiring (except for +24 VDC) is installed correctly:
 - From each IR400 to a directly attached junction box or IR4000M
 - Between IR400 junction boxes or IR4000Ms, and control room devices
 - From each IR4000M to Alarm Relays (optional)
 - If the analog (4-20 mA) output is not used, then the IR400 white signal wire must be connected to ground to prevent a fault condition
2. If the installation includes an IR4000M, verify that the Modbus addresses 10 to 17 are configured for the connected IR400 units.
3. Verify that the IR4000M and IR400 units are properly mounted. Make sure that the conduit/cable gland entries are pointed downward.
4. Make sure that the IR4000M and/or junction box lids are securely installed, unless the area has been declassified.
5. Make sure to inhibit any external devices, such as Trip Amplifiers, PLC devices or DCS systems until after the start-up sequence has completed.
6. Once you are ready to begin the start-up, verify that the power supply is connected properly. The Model IR4000M and IR400 are powered by +24 VDC (20 to 36 VDC voltage range). The IR400 optional LED will output a low voltage fault at 18.5 VDC or below.

3.4.2 Start-up Process for an IR4000M System

NOTE: Powering on and off of the IR4000M and IR400 units is controlled from the external power supply; refer to the power supply manual for instructions. If you have any problems in the start-up or testing of the detector system, please refer to Chapter 6 “*Troubleshooting*” or contact General Monitors Technical Support.

Upon first power-up, the Model IR400 units in the IR4000M system should be allowed to stabilize for approximately 60 minutes while each unit attains the proper operating temperature.

The IR4000M monitor will go through the following process during this period:

- During the Start-Up mode, the LED display will read “**SU**”
- The unit will then enter Operational Mode. It will display the unit with the highest current reading for the IR400 units in the format **N NN**, where:
 - **N** is a number from 1-8 for a particular IR400 unit, and
 - **NN** is a number from 0-99 for the highest % LEL reading

NOTE: The unit number for each IR400 is determined by the Modbus address assigned before beginning the IR4000M system installation.

IR4000M Start-up Operation and Configuration Tasks

In order to make sure that the IR400 detectors and IR4000M menu functions are working correctly, you should perform several tasks immediately after the system is powered on. This section points you to detailed instructions for completing several start-up operation and configuration tasks using the IR4000M menu system:

1. **Use the IR4000M menu to configure the number of connected IR400 detectors.** This step must be done immediately after start-up, to make sure that the IR4000M is reading data from all connected detectors, and to allow for multi-detector commands.
2. **(Optional) Configure additional IR4000M settings, as needed.** You may wish to configure additional operating parameters directly after start-up, or you can use the default settings initially and change them later on.
3. **Zero each connected IR400.** Zeroing eliminates any background gas fluctuations. For instructions, see *Zeroing an IR400* on in Section 4.5.
4. **Perform a gas check test for each connected IR400.** Verify that the IR400 is measuring a known % LEL correctly by placing one or multiple detectors in Gas Check Mode using the IR4000M menu options.
 - You will need to use the GM Gas Check Kit (P/N 31468) to complete this task.
 - For instructions, see *Entering Gas Check Mode* in Section 4.4.
5. **Calibrate connected IR400 detectors, as needed.** If the gas check test indicates that calibration is needed, you can calibrate the detector to eliminate errors that are affecting the measurement process.
 - Apply a 50% LEL gas using a Gas Check Kit (P/N 31468) with portable purge calibrator equipment.
 - For instructions, see *Calibrating an IR400* in Section 4.6.

4.0 Operation and Configuration

4.1 Overview

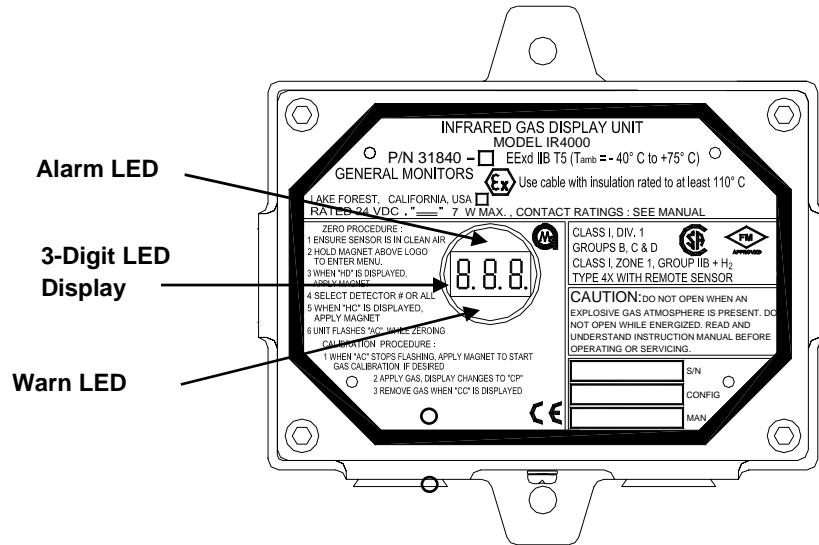

Figure 13: Front Panel LEDs

The Model IR4000M Monitor front panel includes an LED digital display, Alarm and Warning LEDs, and displays a set of menu options that provide the user with the most flexible detector system possible. In addition to the IR4000M menu options for operations and configuration tasks, there is an extensive set of Modbus/HART commands for the same tasks that can be sent from remote Modbus/HART devices in control room areas.

- The IR4000M menu options are described in detail in this section.
- Modbus commands such as the Mode command for viewing operational status, as well as zeroing and recalibrating the detectors, are described in a separate Modbus programming manual available for download from General Monitors' website.
- HART commands are described in the HART Field Device Specification available for download from General Monitors' website.

Using the IR4000M Menus

The IR4000M menus allow you to complete many operational tasks.

- Display the highest % LEL level detected among all connected IR400 units, and view the present % LEL for each individual unit.
- Recalibrate, zero or initiate a gas check for selected IR400 detectors.
- Configure the % LEL required to generate a Warning or Alarm, as well as the warning and alarm relay settings for Energized/De-energized and Latching/Non-Latching.
- Configure Modbus or HART communication settings.

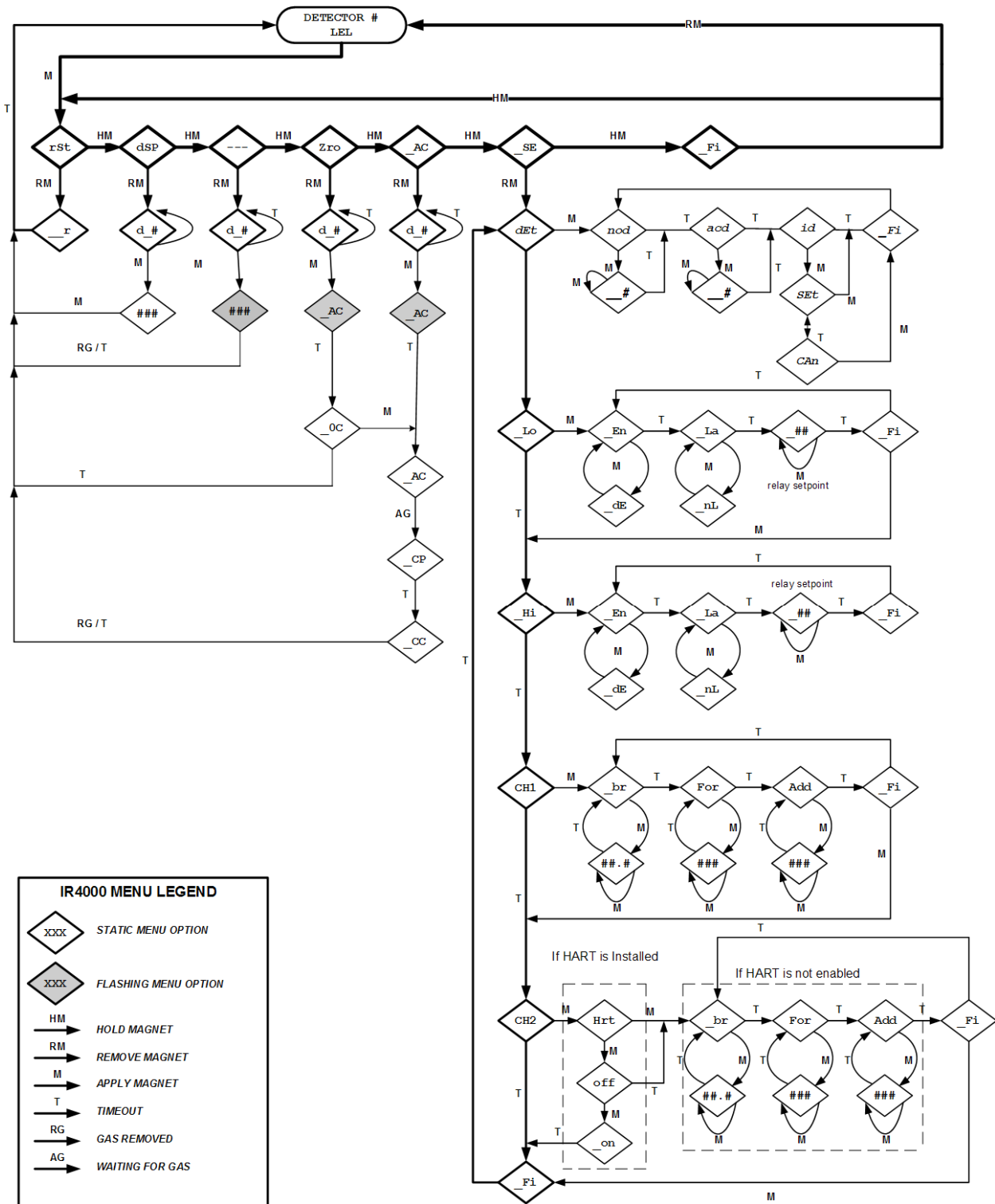

Figure 14: IR4000M Menu Structure



IR4000M Menu Operations Tasks

Following are descriptions of the operations tasks you can accomplish using the main menu display, and submenus. For some tasks, additional actions beyond selecting menu options are described, such as applying gas for the gas check tests and detector calibration.

NOTE: If you begin navigating within the IR4000M menus, then leave the device idle without exiting the menus, a timeout will occur after 15 minutes and the IR4000M will display F8.

4.2 Resetting the Relays (rSt)

NOTE: If the unit was ordered without relays, changing the relay settings will have no effect on the operation of the unit.

The **rSt** main menu option is provided to reset Warning and Alarm relays; if these relays are configured as latching, they must be manually reset after an alarm occurs. The default setting for the IR4000M Warn relay is Non-Latching, and the default setting for the Alarm relay is Latching.

NOTE: Red LEDs above and below the digital display indicate the Alarm and Warning relays are active. Latching relays can only be reset if the gas concentration has fallen below the respective relay setpoint.

To Reset the Relays:

1. **Open the main menu.** Place the magnet on the GM logo on the cover of the IR4000M to move from normal operation to the main menu options.
2. **Select the rSt option.** After a few seconds, the **rSt** main menu option appears. Remove the magnet to select this option.



The message **_r** appears briefly to confirm that the relays are being cleared. Then the unit returns to the default normal operation.

Alternate Methods for Resetting the Relays

In addition to the **rSt** menu option, the relays can be reset in two additional ways:

- Connecting a normally open switch between the IR4000M terminal TB2-7 and TB2-8 (Relay Reset and Common).
- Use IR4000M Modbus or HART command.

4.3 Viewing the Gas Concentration for Selected IR400s

The **dSP** (Display) submenu displays the LED digital display for the selected IR400. The display continues for 15 minutes then returns back to showing the LEL value for the detector with the highest concentration of gas.



4.3.1 To View the Gas Concentration Display(s):

1. **Open the main menu.** Place the magnet on the GM logo to move from normal operation to the main menu options.
2. **Select dSP from the main menu.** Once the **dSP** option appears, remove the magnet to open the **dSP** submenu.
3. **Select IR400 units.** Apply the magnet to the GM logo and numbers from **1** up to the highest IR400 unit online (**8** maximum) will appear. Remove the magnet on the GM logo to select a detector's number. % LEL or fault code for the selected detector will appear. If the detector is in Startup Mode, **SU** will be displayed.
4. **Apply the magnet to the GM logo to return to the main menu.** If you do not apply the magnet, the % LEL display for the selected detector will continue for 15 minutes, and then the IR4000M will return to normal operation.

4.4 Entering Gas Check Mode

Gas Check Mode provides the capability to test the gas detector response with the IR4000M Alarm relays disabled. The Gas Check (- - -) option in the submenu puts the selected IR400 unit into Gas Check Mode; while the unit is in this mode, the Warn and Alarm relays are inhibited from the unit(s).

Upon entering Gas Check Mode, the 4-20 mA output for the selected IR400 will be kept at 1.5 mA to disable the Alarm and Warn relays; the IR4000M analog output will be 1.5 if there is no gas on the other units. If other units see gas, the IR4000M analog output will be proportional to the highest reading.

To Select a Unit and Put it in Gas Check Mode:

1. **Open the main menu.** Place the magnet on the IR4000M GM logo to move from normal operation to the main menu options.
2. **Select “- - -” (Gas Check) from the main menu.** Once the main menu “- - -” option appears, remove the magnet to move to the “- - -” submenu.
3. **Select the IR400 unit number for the gas check.** Apply the magnet to the GM logo and numbers from **1** up to the highest IR400 unit online (**8** maximum) will appear. Remove the magnet on the GM logo to select a detector's number. The detector's gas reading will be displayed.
4. **Apply the test gas.** You must then apply the test gas to the selected IR400 unit(s). Apply a 50% LEL gas using a Gas Check Kit with portable purge calibrator equipment.

NOTE: Gassing into the screened splashguard will not provide a stable or accurate reading.

5. Once the detector is placed in Gas Check Mode and the gas is applied, monitor the % LEL reading for the detector to see if it is functioning properly. When the reading stabilizes, it should be 50% LEL. Calibration is necessary if the reading is outside the allowable range established by your company's maintenance procedures.
6. **Remove the gas.** The unit will return to normal operation when the concentration drops below 5% full-scale. Since the IR400 zeros before calibrating, you must remove the gas completely before going to Calibration Mode.



NOTE: If the Model IR400 is placed in Gas Check Mode and no gas is applied, the unit will return to normal operation after six minutes. If gas is applied for more than six minutes, the unit will revert to a fault condition. After removing the gas, reapplying the magnet will return the unit to normal operation.

4.5 Zeroing an IR400

You can 'zero' one or all of the Model IR400 units in order to eliminate any background gas fluctuations, using the **Zro** option. During Zeroing mode, the analog output for the selected IR400 is kept at 1.5 mA (See Table 5) and the Alarm and Warn relays are disabled. The IR4000M analog output shows the highest % LEL reading for units still online.

To Zero Selected IR400 Unit(s):

1. **Open the main menu.** Place the magnet on the IR4000M GM logo to move from normal operation to the main menu options.
2. **Select Zro from the main menu.** Once the **Zro** option appears, remove the magnet to open the **Zro** submenu.
3. **Select IR400 units.** Apply the magnet to the GM logo and numbers from **1** up to the highest IR400 unit online (**8** maximum) will appear. Remove the magnet on the GM logo to select a detector's number. This will begin zeroing the selected detector. The IR4000M LED will show a flashing **AC** during the zeroing process.
4. When the selected unit(s) have finished zeroing, a solid **0C** will appear for 30 seconds, and then the IR4000M will return to Normal operation (with a % LEL displayed).

NOTE: Reapplying the magnet during the zero process will return the unit to normal operation.

4.6 Calibrating an IR400

You can select to calibrate any of the Model IR400 detectors in order to make sure the LEL measurements are accurate, using the **AC** option in the menu. You can use Gas Check mode to determine if calibration is necessary. During Calibration Mode, the analog output for the selected IR400 is kept at 1.5 mA to disable the Alarm and Warn relays. If any of the other attached detectors senses the presence of combustible gas, the IR4000M analog output shows the highest reading for units still online.

To Calibrate Selected IR400 Unit(s):

1. **Open the main menu.** Place the magnet on the IR4000M GM logo to move from normal operation to the main menu options.
2. **Select AC from the main menu.** Once the **AC** option appears, remove the magnet to open the **AC** submenu.
 - **Select IR400 unit.** Apply the magnet to the GM logo and numbers from **1** up to the highest IR400 unit online (**8** maximum) will appear. Remove the magnet on the GM logo to select a detector's number. This will begin zeroing the selected detector. The IR4000M will flash "**AC**" and the units will begin zeroing. Make sure there is no combustible gas present near the detector.



- After the zeroing has completed, the display will change to a steady “AC.” This indicates that the unit is ready for calibration.
3. **Apply gas to the detector.** Apply a 50% LEL gas using a Gas Check Kit with portable purge calibrator equipment.
 - The display will show a flashing “CP”. If the gas drops below 20% LEL, the display will revert to a steady “CP”.
 - In about one to two minutes, depending on gas flow, the IR400 will complete calibrating and display a steady “CC”.
 4. **Remove the gas.** You will continue to see the “CC” until the gas gets below 5% of full scale. The unit will then return to normal operation.
 5. If calibration doesn’t proceed normally, the IR400 will go into a calibration fault (F2).

NOTE: Once gas has been applied, it is not possible to stop calibration. If no gas is applied for 12 minutes after calibration is selected from the IR4000M menus, the detector automatically reverts to a Fault condition. If the gas is not removed within 12 minutes from the beginning of calibration, the detector automatically reverts to a Fault condition. You must re-apply the magnet over the GM logo and recalibrate.

If no gas has been applied, a calibration can be aborted by reapplying the magnet.

4.7 Setup

This section describes the tasks available using the **_SE** (Setup) submenu, which provides numerous configuration options. The second half of the IR4000M menu shows the **SE** (Base) submenu. Refer to Figure 14.

- **dEt Submenu.** This option selects the number of IR400 units used with a particular IR4000M, ensuring that data is read from each connected detector and number of votes (the number of detectors (votes) that must reach the alarm or warning LEL setpoint before an alarm or warning is triggered).
- **Lo and Hi Submenus.** These submenus configure the % LEL setpoint for the Warn and Alarm relays, as well as Energized/De-energized, and Latching/Non-latching.
- **CH1 and CH2 Submenus.** These submenus configure communications settings such as the baud rate, data bits/parity/stopbits, address setting for the two Modbus channels that go from the IR4000M to control room devices (**CH1** and **CH2**), enables/disables HART on **CH2**.

NOTE: The configuration changes made within the **_SE** submenu will **not** be stored in permanent memory until you exit from the **_SE** submenu, go back through the Main Menu, and select **Fi** (finish) to exit back to normal operation.

4.7.1 Identifying the Number of Detectors (nod) and Votes needed for alarm (Acd)

After powering up a newly installed IR4000M system, or after changing the number of attached detectors, this menu option tells the IR4000M how many IR400 detector units are connected.

To Identify the Number of Detectors:

1. **Open the main menu.** Place the magnet on the IR4000M GM logo to move from normal operation to the main menu options.
2. **Select SE from the main menu.** Once the **SE** option appears, remove the magnet to open the **SE** submenu.
3. **Select dEt from the main menu.** Once the **dEt** option appears, remove the magnet to open the **dEt** submenu.
4. **Select the nod option to open this submenu.** Once the **nod** option appears, apply the magnet to select it.
5. **Select the number of IR400 detectors, from 1 to 8.** Once the desired number appears, remove the magnet to select it.
6. **Select the Acd option to open this submenu.** Once the **Acd** option appears, apply the magnet to select it.
7. **Select the number of Votes from 1 to 8.** Once the desired number appears, remove the magnet to select it.
8. **Set the Detector ID.** If additional IR400 detectors are added to the IR4000M, the detector ID needs to be changed to the format recognizable by the IR4000M. When menu item **id** is displayed, select it by applying and removing the magnet. When **Set** is displayed, select it by applying and removing the magnet. The new detector will now be reprogrammed to the next available ID.
9. **Finish selection and return to the SE submenu.** Once **Fi** appears, apply the magnet and return to the **SE** submenu or pause without applying the magnet to return to step 4.

NOTE: Configuration changes are not stored in permanent memory until you exit from the **SE** submenu, go back through the Main Menu, then select **Fi (finish)** to exit back to normal operation.

4.7.2 Configuring Warning and Alarm Relay Settings

The IR4000M menus allow you to configure the following Alarm and Warn relay settings: Latching versus Non-Latching, Energized versus De-Energized, and the % LEL setpoint.

- The default Warn relay setting is Non-Latching, De-Energized, 30% LEL setpoint.
- The default Alarm relay setting is Latching, De-Energized, 60% LEL setpoint.

NOTE: The settings selected are applied to all connected, online, IR400 units. The Warn relay setpoint must be set lower than the Alarm relay setpoint; neither the Warn nor Alarm setpoints can be higher than 60% LEL.

To Change the Warning and Alarm Relay Settings:

The steps to change the Alarm and Warning relay settings are the same.

1. **Open the main menu.** Place the magnet on the IR4000M GM logo to move from normal operation to the main menu options.



2. **Select SE from the main menu.** Once the **SE** option appears, remove the magnet to open the **SE** submenu.
3. **Select Lo or Hi from the SE submenu.** The **Lo** submenu includes options to configure the Warning relay settings; the **Hi** submenu includes identical options to configure the Alarm relay settings. Use the magnet to select **Lo** or **Hi** once it appears.
4. **Configure the settings for the Lo or Hi submenu.** Three relay settings will appear in turn for the **Lo** or **Hi** submenu. Once you select each setting using the magnet, you will move to the next setting, then to **Finish**.
 - The first relay setting is **En** or **dE** for Energized or De-Energized, respectively. Apply the magnet to select **En** or **dE**, then wait to move on to the next setting.
 - The second relay setting is **La** or **nL** for Latching or Non-Latching, respectively. Apply the magnet to select **La** or **nL**, then wait to move on to the next setting.
 - The third relay setting is the % LEL setpoint, which appears as **NN** from 0-60. Apply the magnet to advance to the setting you wish to select, then wait a few seconds, until **Fi** (Finish) appears.
5. **Select the settings and return to the SE submenu.** Once **Fi** (finish) appears, apply and remove the magnet to finalize the three settings and return to the **SE** submenu. Or pause without applying the magnet to return to step 4.

NOTE: Configuration changes are not stored in the memory until you exit from the **SE** submenu, go back through the Main Menu, and select **Fi** (finish) to exit back to normal operation.

4.7.3 Configuring Modbus 1 and 2 Serial Channel Settings

Channels 1 and 2 are provided to communicate with control room devices using Modbus or HART. CH1 is always Modbus, CH2 can be either Modbus or HART.

- The default Channel 1 settings are Baud Rate = 19,200; Data Format = 8 data bits, no parity, 1 stopbit. (8-N-1); and Modbus Channel Address 1.
- Channel 2 is HART by default. The default Modbus settings for this channel are the same, except it is assigned Modbus Channel Address 2.

To Configure the Modbus Channel 1 and 2 Settings:

Follow these steps to configure the Modbus Channel 1 or Channel 2 for the IR4000M:

1. **Open the main menu.** Place the magnet on the IR4000M GM logo to move from normal operation to the main menu options.
2. **Select SE from the main menu.** Once the **SE** option appears, remove the magnet to open the **SE** submenu.
3. **Select CH1 or CH2 from the SE submenu.** The **CH1** submenu includes options to configure the Channel 1 settings; the **CH2** submenu includes identical options to configure the Channel 2 settings. Use the magnet to select **CH1** or **CH2**.
4. **Configure the settings for the CH1 or CH2 submenu.** Three groups of settings will appear in turn for the **CH1** and four for the **CH2** submenu. Once you select a setting using the magnet, you will move to the next setting, then to **Fi** (Finish).



- **CH2** only has *Hrt* (HART) option: which can be OFF or ON. Apply the magnet to select the desired option and move to Baud Rate in case of Modbus or to **Fi** (Finish) in case of HART.
- The *Baud Rate* choices appear next; they are **24** (2400 bps), **48** (4800 bps), **96** (9600 bps), and **19.2** (19,200 bps). Apply the magnet to advance through the choices. Pause to select the present value and move to the *Data Format* options.
- The *Data Format* choices appear next; they are **8n1** (8 data bits, no parity, 1 stop bit), **8n2 (2 stop bits)**, **8e1 (even parity)** or **8o1 (odd parity)**. Apply the magnet to advance through the choices. Pause to select the present value and move to the *Modbus Channel Address* options.
- The *Modbus Channel Address* values appear next. Apply the magnet to advance from 1-247. Pause to select the present value and select **Fi** (Finish).

NOTE: After you advance through five address numbers, you can hold the magnet in place to advance faster. The Modbus Channel 1 and Channel 2 addresses can be identical.

5. **Complete the settings and return to the SE submenu.** Once "**Fi**" appears, apply and remove the magnet to finish your selections and return to the **SE** submenu. Or pause without applying the magnet to return to step 4.

NOTE: Your configuration changes are not stored in permanent memory until you exit from the **SE** submenu, go back through the Main Menu, then select **Fi** (finish) to exit back to normal operation.

5.0 Maintenance



WARNING: Disconnect or inhibit external devices such as Trip Amplifiers, PLC's, or DCS systems before performing any maintenance.

NOTE: The system's full two-year warranty will be voided if customer personnel or third parties damage the system during repair attempts or maintenance activities.

5.1 Developing a Maintenance Schedule

Maintenance requirements will vary with each installation; General Monitors recommends that a schedule for periodic maintenance be established and followed, and that a maintenance logbook be kept for each unit in operation.

More frequent cleaning and calibration checks are recommended if the equipment is impacted by unusual environmental conditions such as mud collecting on the detector windows, detectors accidentally being painted over, etc.

General Monitors is not implying that the customer should expect problems with detector life or stability, but calibration checks ensure the integrity of the life protecting equipment.

5.2 Gas Checks, Zeroing and Recalibration

For detailed instructions on initiating gas checks, zeroing and calibration using the IR4000M menus, see Sections 4.4 - 4.6.

For information on the Modbus IR4000M register *Operating Mode* commands for gas checks, zeroing and calibration, refer to the IR4000M Modbus manual available for download from the General Monitors' website.

5.3 Lubricating Threads and Seals

If the neoprene rubber gasket (O-ring) in the cover of the IR4000M enclosure is found dry, it should also be lubricated with the lubricant/sealant that is included with the IR400/IR4000M units, or is available on order from General Monitors (P/N 610-010).

As an alternative to grease, PTFE (Teflon) tape may be used.

5.4 Replacing an Attached Detector

In the unlikely event that an IR400 detector attached to the system malfunctions, the IR4000M will alternately flash the unit number and the fault code. Most faults can be corrected in the field by consulting Section 6.0 - Troubleshooting. If the fault cannot be corrected the detector must be replaced. After declassifying the area, open the junction box that has the detector attached and disconnect all the wires to the detector from the terminal block. Unscrew the detector from the junction box and a replacement mounted in its place. Reattach the wires in the junction box following the instructions in Section 3.3. Re-seal the junction box and ensure that the X/P integrity is maintained by following Section 5.5. If the replacement detector had been setup with the same Modbus ID as the one that failed then the system should now be working. However,



the default Modbus ID for an IR400 shipped from General Monitors is 1 and this does not match the required range for detectors connected to an IR4000M. To change the ID from 1 to the correct ID, enter the Setup Menu as described in section 4.7. Use Figure 14 to navigate to the item menu Id in the dEt menu. When you select the menu item Set, the new detector will be reprogrammed to the same ID as the one replaced. All detectors should now be functioning correctly.

5.5 Maintaining the X/P Integrity

The IR4000M Monitor is rated explosion-proof for use in the following hazardous locations:

Class I, Division 1, 2 Groups B, C, D and Class I, Zone 1, IIB+H₂, T5
Ex d IIB + H₂, T5
Ex t IIIB, T100°C Db IP66

Before the cover of the IR4000M Monitor is removed, or the cover bolts are loosened and power is to be left on, it is necessary to declassify the area. When replacing the cover, the gap between the lid and the housing should be less than .0015 inch (.038 mm). Make sure that the flame-path is clear of dirt and debris before replacing the cover. Tighten the cover bolts to a torque setting of 50 inch-pounds. Use a feeler gauge to ensure the gap between the cover and the housing is less than .0015 inch (.038 mm).

There are four entry holes in the IR4000M housing. These holes can be used to attach an IR400 detector directly, as well as for wiring conduits to alarm relays and control room equipment.

Each hole is tapped for 3/4" NPT threads. If a particular entry hole is not used, it must be plugged during operation in the field. The factory installs plugs in the unused entry holes, except one. A red plastic cap is placed into the remaining hole and must be removed before conduit can be attached to the housing.

When an IR400 Gas Detector or other device is attached to the IR4000M housing, it must be screwed into the housing using five to seven turns to ensure that the explosion-proof integrity of the housing is maintained.

5.6 Storage

The IR4000M Monitor should be stored in a clean, dry area, and within the temperature and humidity ranges noted for environmental specifications in Section 9.2.6. Insert red dust caps into any vacant cable entry holes.

6.0 Troubleshooting



CAUTION: Component level repair must be undertaken either by General Monitors personnel, or by competent, authorized service engineers. SMT PCB repair shall only be performed at a General Monitors facility. Failure to comply with this requirement will invalidate the warranty.

Be sure to inhibit or disconnect the external alarm wiring before making any check which might send the unit into alarm.

IR4000M Fault Codes and Remedies

The Model IR4000M has its own separate set of fault codes that appear on the IR4000M 3-digit display. If the letter “b” precedes the two-digit fault code from F0-FF, then this indicates a base unit fault. If the fault is for one of the connected detectors then the detector number is shown on the left most digit of the three digit display, then ½ a second later the fault code is shown. This is written in the next section as a # symbol followed by the code. For example, if detector 2 has a “*Low IR Fault*” the IR4000 display will first show the number 2 (for detector 2) then show F3 (Low IR Fault).

#F0 Excess Negative Drift Fault

Indicates excessive negative drift on the IR400 unit # as reported by the IR4000M.

ACTION – Clean detector beam path and windows. Zero and calibrate the IR400 if necessary.

#F1 Negative Drift or Close to Low IR Fault

Indicates negative drift or IR signal close to low level on the unit # as reported by the IR4000M.

ACTION – Clean detector beam path and windows.

#F2 Calibration Fault

Indicates that the IR400 slave unit # needs recalibration.

ACTION – Recalibrate the IR400 slave unit #. Make sure that there is plenty of gas in the test gas bottle and that the tubing from the test gas bottle to the calibration cup is not twisted or blocked. If the problem persists contact the factory or authorized service center for repair.

#F3 Low IR Fault

Indicates low IR signal on the IR400 unit # as reported by the IR4000M.

ACTION – Clean detector beam path and windows.

#F4 Communication Fault with Unit

Indicates that the IR4000M does not communicate with the IR400 slave unit # (flashing).

ACTION – Check wiring and IR400. Note that there are two Modbus connections for each detector (Mod+ and Mod-) and both must be connected. The IR400 Modbus address must have



been correctly set before installation. The first IR400 must have address 10, the next 11 etc. up to the maximum detector number 8, which has an address of 17.

bF5 Short Wire Base Fault

Indicates that the CAL IN (TB1-2) Reset Relay (TB2-7) on the IR4000M unit has been shorted to ground for more than 30 seconds.

ACTION – Disconnect any wires from TB2-7, if the fault clears then there is a problem with the wiring. If the fault does not clear, contact the factory or authorized service center for repair.

#F5 Cal IO Slave Fault

Indicates that the Cal IO wire for the IR400 slave unit # has been grounded for over 30 seconds.

ACTION – Disconnect the brown Cal IO wire from the junction box connected to the detector that is showing the fault. If the fault does not clear, contact the factory or authorized service center for repair.

bF6 Low Line Condition

This fault occurs if the supply voltage at the IR4000M drops below +18.5 VDC.

ACTION – Check power supply voltage and wiring and ensure that the supply voltage is at least +20 VDC at the Model IR4000M.

#F6 Low Line Slave Condition

This fault occurs if the supply voltage at the IR400 slave detector #, connected to the IR4000M, drops below +18.5 VDC.

ACTION – Check power supply voltage and wiring and ensure that the supply voltage is at least +20 VDC at the IR400 detector # indicated.

bF7 Base Memory Fault

This fault indicates that the IR4000M memory (ROM, RAM or EEPROM) is not working properly. This usually occurs when powering the unit up after a lightning strike or large voltage transient on the power or signal lines to the unit.

ACTION – Turn off the 24V power to the IR4000M and the attached IR400. Wait for 1 minute then turn the power back on. After 2 minutes the IR4000M will show one of the following faults:

F2 – The fault was found and corrected but the attached IR400 must be recalibrated. See the procedure Calibrating an IR400 in Section 4.6 of this manual.

F7 – The fault could not be corrected. Contact your local General Monitors representative. See Section 8.0, Customer Support.

F8 – The fault was found but the setup menu items had to be reset to default values. You must check every value in the SE menu and check it is set correctly. Failure to do so could result in unexpected operation.



#F7 Critical Slave Fault

Indicates a critical fault on the slave IR400 unit #, which prevents the proper detection of gas. Such IR400 faults are:

- Reference or active lamp failures
- IR400 code checksum faults
- IR400 memory faults (RAM, ROM, EEPROM)

ACTION – The IR400 unit # must be returned to the factory or authorized service center for repair.

#F8 Zeroing Fault

Indicates that the IR400 slave unit # needs re-zeroing.

ACTION – Zero the IR400 slave unit #, and if the problem persists, contact the factory or authorized service center for repair.

bF8 Setup Menu Timeout

Indicates that the unit has been left in setup mode for more than 15 minutes. Setup is not complete.

ACTION – Apply the magnet to the IR4000M unit. Reenter the Setup menu if it is necessary to change any configuration options.

#F9 Gas Check Failure

Indicates that gas has been applied for over 12 minutes to the IR400 unit # in gas check mode.

ACTION – Remove the gas applied to the IR400 unit #. The unit should get out of fault condition as soon as the gas concentration falls below 5% LEL.



7.0 Modbus Interface

The IR4000M has two available Modbus communications channels. There is a separate manual available from General Monitors' website that describes the Modbus registers and functions.

8.0 Customer Support

General Monitors provides extensive documentation, white papers and product literature for its complete selection of safety products. A selection of these documents are available online at the General Monitors website at <http://www.generalmonitors.com>.

Contacting Customer Support

Worldwide Customer Service and Technical Support are available by calling one of several General Monitors offices, listed in the following table:

General Monitors Offices

AREA	PHONE/FAX/EMAIL
UNITED STATES	
Corporate Office: 26776 Simpatica Circle Lake Forest, CA 92630	Phone: +1-949-581-4464 (24 hours) Fax: +1-949-581-1151 Email: info@generalmonitors.com
Texas Office: 9776 Whithorn Drive Houston, TX 77095	Phone: +1-281-855-6000 Fax: +1-281-855-3290 Email: gmlhou@generalmonitors.com
IRELAND	
Ballybrit Business Park Galway Republic of Ireland	Phone: +353-91-751175 Fax: +353-91-751317 Email: service@gmil.ie
MIDDLE EAST	
LOB12, #G20 P.O. Box 61209 Jebel Ali, Dubai United Arab Emirates	Phone: +971-4-8815751 Fax: +971-4-8817927 Email: gmme@emirates.net.ae
SINGAPORE	
No. 2 Kallang Pudding Rd. #09-16 Mactech Building Singapore 349307	Phone: +65-6748-3488 Fax: +65-6748-1911 Email: genmon@gmpacifica.com.sg
UNITED KINGDOM	
Lyme Green Business Park Macclesfield, Cheshire, United Kingdom, SK11 OLR	Phone: +44-1625-619-583 Fax: +44-1625-619-098 Email: info@generalmonitors.co.uk

9.0 Appendix

9.1 Warranty

General Monitors warrants the Model IR4000M to be free from defects in workmanship or material under normal use and service within two (2) years from the date of shipment.

General Monitors will repair or replace without charge any such defective equipment found to be defective during the warranty period. Full determination of the nature of, and responsibility for, defective equipment will be made by General Monitors' personnel.

Defective or damaged equipment must be shipped prepaid to General Monitors' plant or representative from which shipment was made. In all cases this warranty is limited to the cost of the equipment supplied by General Monitors. The customer will assume all liability for the misuse of this equipment by its employees or other personnel.

All warranties are contingent upon proper use in the application for which the product was intended and do not cover products which have been modified or repaired without General Monitors' approval, or which have been subjected to neglect, accident, improper installation or application, or on which the original identification marks have been removed or altered.

Except for the express warranty stated above, General Monitors disclaims all warranties with regard to the products sold, including all implied warranties of merchantability and fitness and the express warranty stated herein are in lieu of all obligations or liabilities on the part of General Monitors for damages including, but not limited to, consequential damages arising out of/or in connection with the use or performance of the product.

9.2 Specifications

9.2.1 Agency Approvals

CSA certified to C22.2 No.152-M1984 (R2001) when connected to a detector that also meets the standard.

FM 6310, 6320 January 2001 when connected to a detector that also meets the standard. Complies with ANSI/ISA-12.13.01-2000.

ATEX safety and IECEx approved.

CE Marking.

SIL 2 suitable.

HART Registered.

FM requires the following statement: This Approval does not include or imply Approval of apparatus to which the subject instrumentation may be connected. In order to maintain an FM Approved system, the apparatus to which this instrument is connected, must also be Approved by FM Approvals.



9.2.2 System Specifications

Electrical Classification:

CSA/FM:	Class I, Division 1, 2, Groups B, C, D and Class I, Zone 1, IIB+H ₂ , T5. Type 4X
ATEX:	Ex d IIB + H ₂ , T5 Gb (Ta = -40°C to +75°C) Ex t IIIB, T100°C Db IP66

9.2.3 Mechanical Specifications

Length	6.5 inches (165 mm)
Width	6.0 inches (152 mm)
Height	3.21 inches (82 mm)
Weight	5.5 lbs. (2.5 kg)
Mounting Holes	5.05 inches (128 mm) (center to center)

9.2.4 Electrical Specifications

Input Power	
absolute min (V)	20
nominal (V)	24
absolute max (V)	36
Max. Wattage at +24 VDC (W)	2.4
Max. Current at +24 VDC (mA)	100
Relay Ratings	
VAC	8 A @ 250 V
VDC	8 A @ 30 V
Analog Signal	
Range	0-21.7 mA
Load (Ohms max)	500

Current Level (mA)	Meaning
0	Startup mode and critical fault for non-HART unit
1.25*	Startup mode and all faults for HART units
1.5*	Zero, Calibration and Gas Check Mode
2.0*	Dirty optics
4 – 20	0 – 100 % LEL
20.1 – 21.7	Over range

* Under HART, the analog output minimum level can be configured as 3.5 mA or as stated above, depending on user selection.

Status Indicators: Three-digit digital display with gas concentration, Warn and Alarm LED's, calibration prompts, fault codes, and setup options.



RS-485 Output:	(Optional) Dual Redundant Modbus RTU, suitable for linking up to 128 units or 247 units with repeaters.
Baud Rate:	2400, 4800, 9600, or 19200 BPS
HART:	HART 6, HART Device Descriptor Language available. AMSAware
Cable Length Requirements:	3-wire shielded cable. Max. distance between IR4000M and power source at 24 VDC nominal (20 Ohm loop)

AWG	Ohms/1K	FEET	METERS
12	1.588	4143	1263
14	2.525	2606	794
16	4.016	1638	499
18	6.385	1030	314
20	10.15	648	198

Table 3: 24 VDC Cable Lengths

Maximum distance for analog output (500 Ohms max):

AWG	Ohms/1K	FEET	METERS
14	2.525	9000	2740
16	4.016	5200	1585
18	6.385	3800	1160
20	10.15	2400	730

Table 4: Analog Output Cable Lengths

RFI/EMI Protection: Complies with EN50270

NOTE: *European Union (EU) Approved Applications:* PSU noise and ripple voltage 1.0 Vpp max. The customer supplied PSU must comply with IEC 61010-1, limiting current to 8 A under Fault conditions, in order to comply with CE Marking requirements.

9.2.5 Analog Current Output

The following table shows the values of the analog output when in certain modes or fault conditions. The command override allows a user to adjust the lower level of the analog output in installations where a host computer may require a higher minimum output in order to function correctly.

Condition Type	Non-HART Units	HART Units	Cmd Override
Fault	0 mA	1.25 mA	3.5 mA
Zero, Gas Check or Cal	1.5 mA	1.5 mA	3.5 mA
Dirty Optics	2.0 mA	2.0 mA	3.5 mA

Table 5. Analog Current Output Table

9.2.6 Environmental Specifications

Temperature Range	
Operating	-40°F to 167°F (-40°C to +75°C)
Storage	-58°F to 185°F (-50°C to +85°C)
Humidity Range	5 to 100% RH non-condensing

9.3 Modbus Interface

The Model IR400 and Model IR4000M have built-in serial communications in the form of a half-duplex RS-485 digital serial interface designed to conform with EIA-485 specifications. Modbus is a widely used serial communication protocol for the RS-485 IEEE standard. The customer must provide access to the RS-485 bus by way of a PLC or other controlling device (bus master) with communications software programmed to provide Modbus command information to the IR400 and IR4000M.

RS-485 Line Termination

Most RS-485 buses require termination because of fast transitions, high data rates, or long cables. The purpose of the termination is to prevent adverse transmission-line phenomena, such as reflections. The main point to remember is that if you use termination, you must locate the termination networks at the two extreme ends of the cable, not at every node. A common mistake is to connect a terminating resistor at each node; this practice will cause trouble on buses that have four or more nodes.

RS-485 Termination Options

There are several options for terminating an RS-485 bus. The first option is no termination. However, this option is feasible only if the cable is short and the data rate is low. The most popular termination option is to connect a single resistor across the conductor pair at each end. The resistor value matches the cable's differential-mode characteristic impedance. If you terminate the bus this way, no reflections occur and the signal fidelity is very good. The problem with this option is that power is dissipated in the termination resistors. Another popular option is a modified parallel termination that also provides a fail-safe bias. The following figure shows this popular termination method.

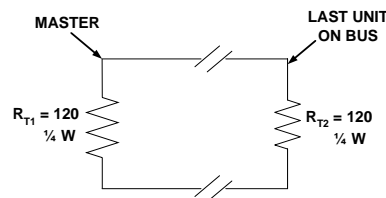

Figure 15: Simple RS-485 Termination

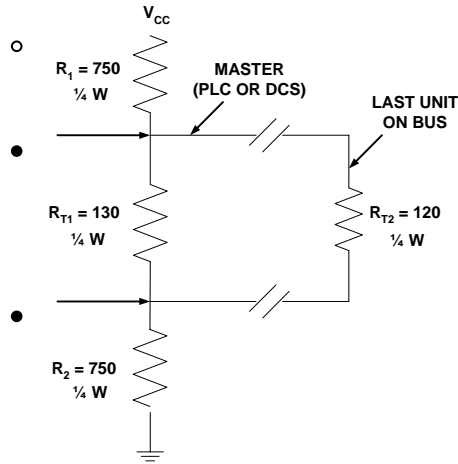

Figure 16: RS-485 Termination with Fail-Safe Biasing

NOTE: The Model IR4000M, acting as the bus master in an IR400 system, already contains the Bias Resistors R_1 , R_2 , and R_{T1} . However, the termination resistor (R_{T2}) must still be added to the last unit on the bus.

For Further Information

To learn more about methods to implement RS-485 termination, review the following documents:

Goldie, J, "AN-847: Fail-safe biasing of differential buses," *Interface Databook*, National Semiconductor Corp, 1996.

Goldie, J, "AN-1057: Ten Ways to Bulletproof RS-485 Interfaces," *Interface Databook*, National Semiconductor Corp, 1996.

9.4 Ordering Information

IR4000M System Components

IR4000M	Model IR4000M Multi-Point Monitor
MANIR4000M	Model IR4000M Instruction Manual
IR400	Model IR400 Combustible Gas Detector (up to 8 per system)
MANIR400	Model IR400 Combustible Gas Detector Manual

IR4000M Spare Parts and Accessories

To order spare parts and/or accessories, please contact your nearest General Monitors Representative or General Monitors directly, with the following information:

- Part Number of Spare Part or Accessory
- Description of Spare Part or Accessory
- Quantity of Spare Part or Accessory

Replacement Parts

32491-1	Control Board Electronics
32951-1	HART Control Board Electronics
32451-1	Output Board Electronics
32441-1	Display Board Electronics
31772-1	Enclosure Cover Assembly with Window
31195-2	Enclosure Base Assembly
30051-1	Explosion-Proof SPST Switch
30060-1	Calibration Magnet
925-5007	Cover Assembly, O-Ring

Recommended Spare Parts for One (1) Year

30060-1	Extra Calibration Magnet (Qty. 1)
----------------	-----------------------------------



ADDENDUM
Product Disposal Considerations

This product may contain hazardous and/or toxic substances.

EU Member states shall dispose according to WEEE regulations. For further General Monitors' product WEEE disposal information please visit:

www.generalmonitors.com/customer_support/faq_general.html

All other countries or states: please dispose of in accordance with existing federal, state and local environmental control regulations.