



# COMBUSTIBLE GAS SAFETY MONITORING: INFRARED VS. CATALYTIC GAS DETECTORS



**GENERAL MONITORS**

*Protection for life.*

## INTRODUCTION

When designing a combustible gas safety monitoring system for oil/gas, petrochemical or other applications, how do you decide whether to use infrared or catalytic gas detector technology? Both sensing technologies have their advantages dependent upon your application's specific requirements. A thorough analysis of your application's unique field environment is needed to ensure optimal performance, safety, reliability and cost-effectiveness. A quick decision, of course, can lead to poor detector choices as well as safety, performance, maintenance, and life-cycle cost consequences.



As a global leader and innovator in gas sensing technologies, General Monitors offers the industry's two most popular and reliable combustible gas

sensing technologies: (1) catalytic detectors and (2) infrared detectors. Both technologies reliably detect gas at or below the lower explosive limit (0-100% LEL). They are also suitable for use in a broad variety of field application environments (see Table 1 for a list of gases typically monitored). Determining which sensing technology is the best fit for your individual application is extremely important. Our field applications engineers will help you conduct a risk assessment audit to determine the requirements for your safety monitoring system.

Typical Gases Monitored	Other Gases Monitored
<ul style="list-style-type: none"> <li>• Methane</li> <li>• Ethane</li> <li>• Propane</li> <li>• Butane</li> <li>• Hexane</li> <li>• Butadiene</li> </ul>	<ul style="list-style-type: none"> <li>• Isopropylamine</li> <li>• Propylene</li> <li>• Ethylene Oxide</li> <li>• Propylene Oxide</li> <li>• Ethanol</li> <li>• Methanol</li> </ul>

Table 1: Gases Monitored

## CATALYTIC SENSING

Catalytic (or electrocatalytic) detectors (Fig. 1) are based on a highly responsive technology with over 39 years of proven field experience. They are single-point detectors for combustible gas detection. Based upon the simple principle that as combustible



Figure 1: S4000C Intelligent Combustible Gas Detector

gas oxidizes it produces heat and the sensor converts the temperature change via a standard Wheatstone Bridge-type temperature transducer to a sensor signal. The sensor components consist of a pair of platinum heating coils embedded in a catalyst. Since the reactants are all gaseous, the reaction takes place on the surface of this element with the combustible gases reacting exothermically with oxygen in the air to raise its temperature. This results in a change of resistance within the embedded coil, which is linearly proportional to gas concentration.

General Monitors' catalytic detectors utilize a pair of catalytic beads that are identical except for a glass coating on one of them (Fig. 2). This method of providing an inert "reference" bead ensures it remains permanently non-responsive to gas, thereby acting as a stable "baseline" signal generator to compensate for environmental changes which would otherwise affect the sensor's stability. Glass-coating is a unique feature of our catalytic detectors and the physical and electrical matching of the bead pairs eliminates the need for compensating resistors which cause drift in operation.

The secret of a catalytic detector's accuracy, longevity and reliability is in the design of the substrate and catalyst system. It is critical to maintain an abundance of active sites as some may become poisoned in service. We achieve this by using a highly porous substrate with catalyst deposition down to the core.

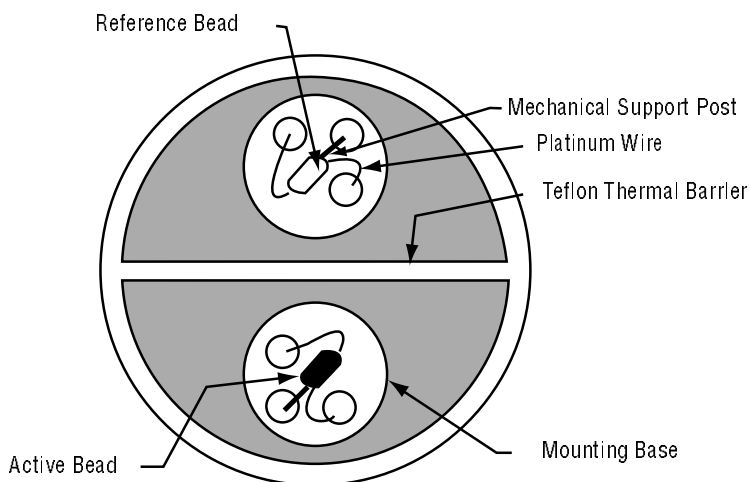

Figure 2: Catalytic Bead Sensor

## Advantages

The major advantages of catalytic detectors are that they are:

- Robust
- Simple to operate
- Easy to install, calibrate and use
- Long lived with a low life-cycle cost
- Proven technology with exceptional reliability and predictability
- Immensely flexible with application
- Easily calibrated individually to gases such as hydrogen which cannot be detected using infrared absorption

## Disadvantages

The limiting factors in catalytic detector technology are that:

- Catalysts can become poisoned or inactive due to contamination.
- The only means of identifying detector sensitivity loss due to catalytic poisons is by checking with the appropriate gas on a routine basis and recalibrating as required.
- When a sensor is located in an area known to contain potential poisons, it should be calibrated at regular intervals and the results should be logged. The interval between calibrations should be recommended by the manufacturer and then verified in the field.
- Requires oxygen for detection.
- Prolonged exposure to high concentrations of combustible gas may degrade sensor performance.

## INFRARED DETECTORS

Gas sensing by the Infrared (IR) detection method is based upon the absorption of infrared radiation at specific wavelengths as it passes through a volume of gas. General Monitors' IR detection technology incorporates a light source and a light detector that measures the intensity of two different wavelengths, one at the absorption wavelength and one outside the absorption wavelength. If a gas intervenes between the source and the detector, the level of radiation falling on the detector is reduced and can

be continuously monitored. Gas concentration is determined by comparing the relative values between the two wavelengths.

Infrared gas detection is based upon the ability of some gases to absorb IR radiation. It is generally understood that almost all hydrocarbons absorb IR at approximately 3.4 micrometers and at this region H<sub>2</sub>O and CO<sub>2</sub> are relatively transparent. It follows, therefore, that a dedicated spectrometer operating at this wavelength could be used to detect combustible hydrocarbons in the air.

In IR point detectors, there is a fixed path length between the IR source and the IR detector (Fig. 3). The path length is typically short (a few inches) and the gas concentration is assumed uniform across the path. With a fixed path length, the measurement of IR beam absorption by the gas being measured can be expressed directly (% LEL in this case). Thus, a point IR detector is capable of giving a true measurement of gas concentration at the point of detection. Open path IR detectors, as opposed to point detectors, expand the gas sampling path from a few inches up to 100 meters to monitor large facilities for gas clouds (Fig. 4 and 5).

### Advantages

The major advantages of IR gas detectors are:

- Immunity to contamination and poisoning
- Fail-to-safe operation
- No routine calibration
- Ability to operate in the absence of oxygen or in enriched oxygen
- Ability to operate in continuous presence of gas

With the sophisticated optical designs currently in use, IR detectors are factory calibrated and are virtually maintenance free. They are particularly desirable where detectors must be located in inaccessible areas. Maintenance is limited to periodic cleaning of the optical windows to help ensure dependable performance.

### Disadvantages

The limiting factors in IR technology are:

- The initial higher cost per point. IR detectors in the past have been more expensive than catalytic detectors at initial purchase, but they are rapidly coming down in price to cost parity with catalytic detectors.
- Higher spare parts cost.
- The gas to be measured must be infrared active, such as a hydrocarbon.
- Gases that do not absorb IR energy (such as hydrogen) are not detectable.
- High humidity, dusty and/or corrosive field environments can increase IR detector maintenance costs.
- Routine calibration to a different gas is not practical.
- A relatively large volume of gas is required for response testing.
- Ambient temperature for detector use is limited to 70°C.
- Does not perform well for multiple gas applications.
- Cannot replace the IR source in the field – must be returned to factory for repair.

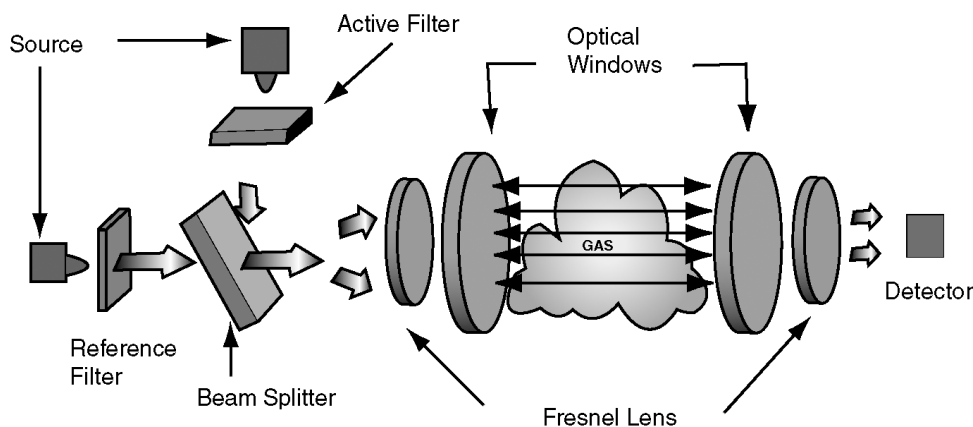

Figure 3: Model IR2100 Point Detector - optical scheme



Figure 4: IR2100 IR Point Detector and IR5000 Open Path Detector for Hydrocarbon Gas

## Site Location and Experience

Both IR point detectors and catalytic detectors enjoy long life expectancies even in severe environments such as the North Sea. In the harsh environments of refineries, IR detectors offer fail-to-safe operation, but still should be checked with gas periodically to verify that gas is free to enter the optical path. Splashguards and dust shields can become blocked in certain conditions or environments. Experience has shown that users of both IR and catalytic technology do prefer to check the detectors with gas, and as such, perhaps there is no significant difference in the overall maintenance requirements. In climates with low and high temperature extremes, very humid conditions, and around hot or vibrating machinery, catalytic detectors are the best choice.

## APPLICATION REQUIREMENTS

There are many important factors to consider when deciding whether to select an infrared or catalytic detector for a particular application. Reliable application of either infrared or catalytic detectors depends on a detection system that matches the detectors and sampling techniques to the monitored area. It's important to recognize that different gases can require different detection technologies. No single detection principle can provide the sensitivity and response time required for every gas. Similarly, the detector heads must be matched to ambient conditions surrounding the measurement point. General Monitors' field engineers can help you determine which factor is the most critical to the success of your application.

## Calibration of Detectors

Measurement quality with both combustible and IR gas detectors is dependent upon accurate calibration with known gas concentrations. Both IR and catalytic bead detectors from General Monitors are smart microprocessor-based devices featuring single-point calibration. They feature an automatic calibration adjustment sequence with no tools or area declassification necessary. Just activate and apply the calibration gas.

## Placement of Detectors

For IR and catalytic detectors, there are three types of monitoring strategies: (1) point, (2) area, and (3) site perimeter. When you know the potential source of a gas leak, you can design a point monitoring

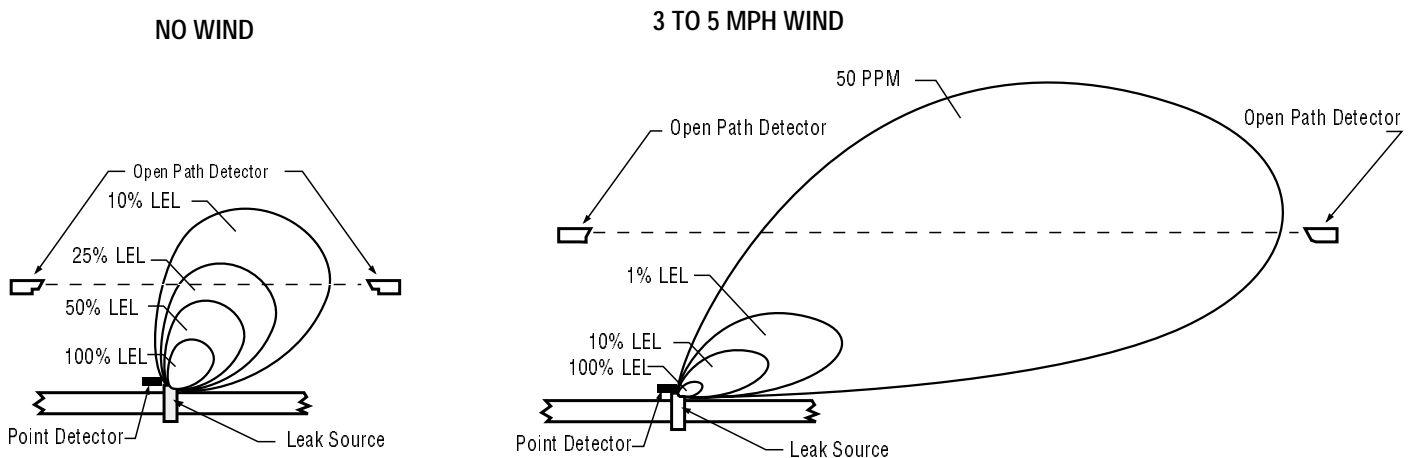

Figure 5: IR5000 and evolution of a leaking gas cloud

strategy to place detectors close to the potential leak sources, such as tank valves, so that detection is prompt. In large refining or chemical processing plants, a point detector grid system can be developed to monitor specific zones, such as a storage tank area. (Fig. 6)

For plants where the site layout makes it difficult to identify specific leak sources that may spread into other locations, a wider area monitoring system can be developed with point gas detectors placed at preset geographic distances. Some plants also

require outer perimeter monitoring along property fence lines to guard against gas passing beyond the facility's boundaries. In some cases, open path IR detectors may be useful in detecting gas clouds that can become airborne and/or disperse over a wide area. (Fig. 5)

### Detector System Communication

Infrared and catalytic detectors from General Monitors provide both 4-20mA analog and RS-485 serial output that is MODBUS protocol compatible

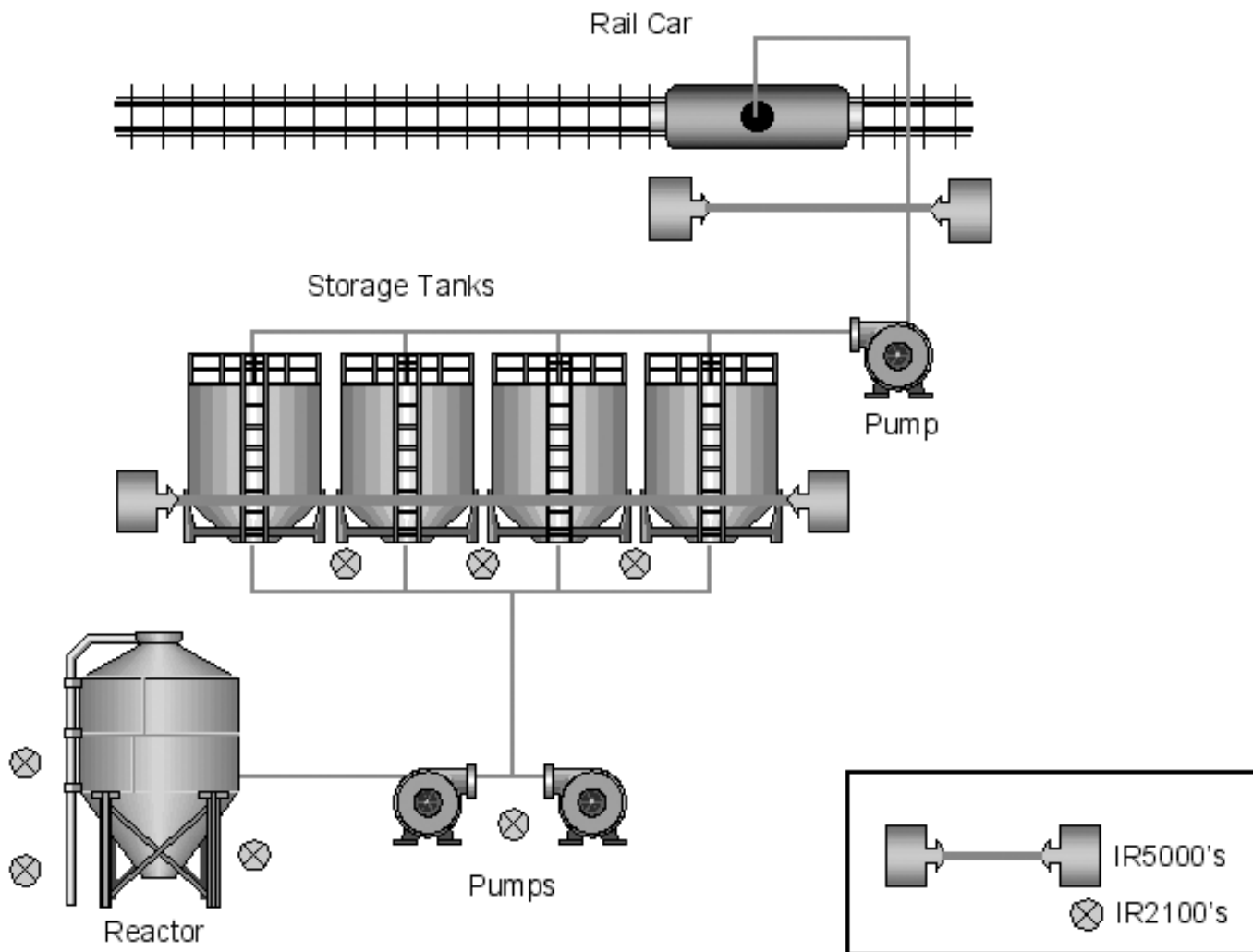

Figure 6: Typical Installation for Point and Open Path Gas Detectors

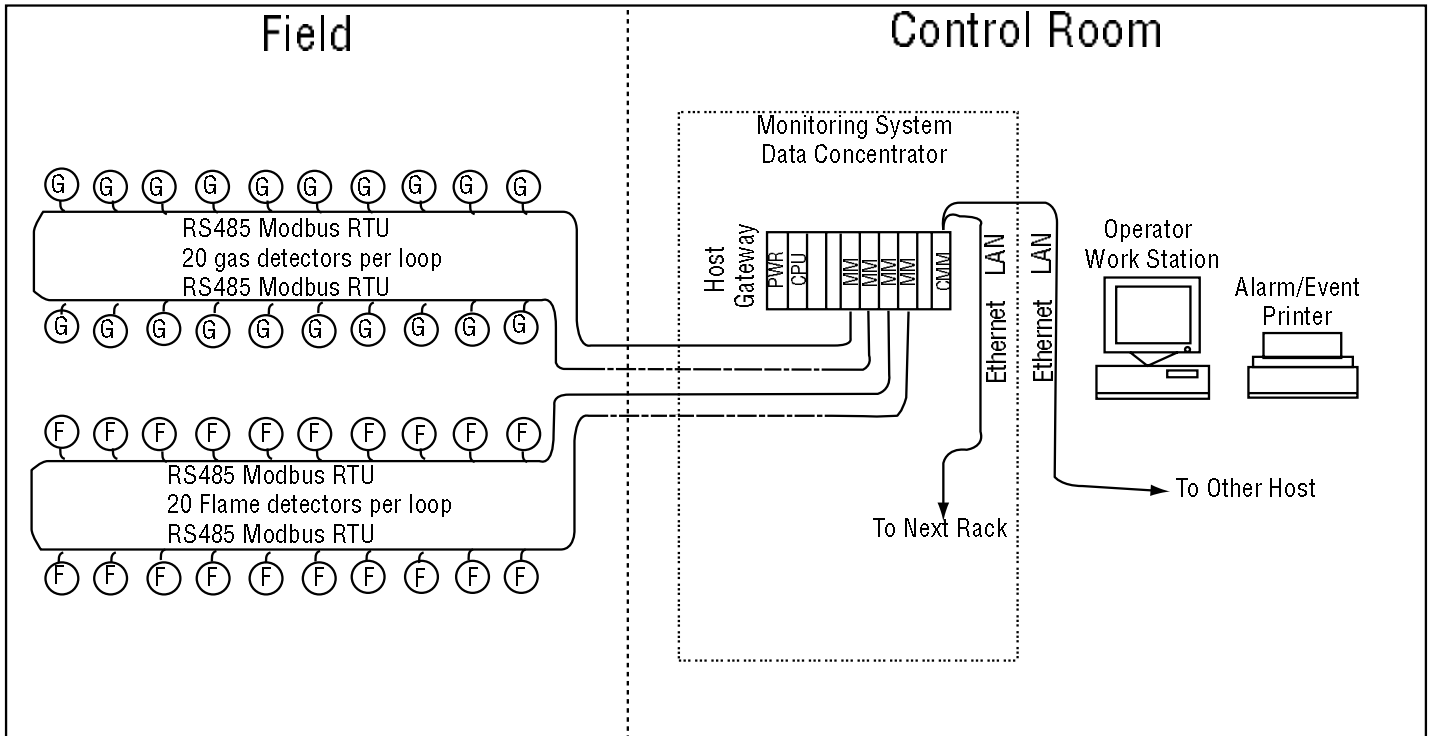

Figure 7: Multi-drop Addressable System

for use in large distributed control systems. Using a MODBUS compatible remote transmitter unit (RTU) provides two-way addressable communications for status, alarm, fault and other information for operation, troubleshooting or programming of the detectors. Up to 128 point detectors may be networked in series, and up to 247 point detectors can be networked with repeaters. A typical system configuration linking 20 gas detectors and 20 flame detectors is shown in Figure 7.

### Maintenance and Repair

Catalytic gas detectors require a routine “check” every 90-days. While no routine calibration is actually required for IR detectors, a gas check is still recommended every 90-days. Typically, calibration takes between 1 – 3 minutes. Should a catalytic sensor require replacement, it can easily be changed out in the field. IR point detectors require factory repair, however repair frequency is typically very low. Also, a spare IR detector can be installed while the defective one is sent to the factory.

### Expected Detector Life

Both catalytic and IR gas detectors from General Monitors have a sensor life expectancy of up to five

years. Catalytic detectors can be calibrated 50 times with one cylinder of gas. IR detectors require no routine calibration, however if calibration is performed, they are limited to 10 times maximum per cylinder of gas. The initial cost of catalytic detection is typically lower than IR, but overall IR maintenance costs are lower.

### Life-Cycle Cost Analysis

Both IR point detectors and catalytic detector/transmitters share similar installation and wiring costs. Inspection frequency is the same for both, but IR detectors feature self-diagnostics while catalytic detectors require a gas check. IR detectors do not require routine calibration, however 90-day gas checks are recommended. In many circumstances, repair data shows catalytic detectors may be more quickly repaired in the field than IR detectors that often require factory expertise for repair. This minor inconvenience, however, is easily overcome by keeping a spare IR detector on hand in the unlikely event that repair is needed.

### Performance and Reliability

While IR detectors do offer enhanced reliability due to their fail-to-safe style, immunity to poisons, and

ability to function without oxygen, catalytic detectors offer application flexibility, simple maintenance and low replacement costs. Both technologies are reliable, fast detecting and accurate. Neither is necessarily the answer to everything, and in most plants, a combination of both types is the correct and sensible solution.

## **CONCLUSION**

There is clearly a requirement for both IR and catalytic detectors. When making a choice, be sure

to strongly consider the field environment and variables in detector design from manufacturer to manufacturer. Life-cycle cost assumptions will not hold true in all environments. The same can be said for detector mean-time-to-repair or failure data among various manufacturers. Careful analysis of detectors, suppliers and field experience will help you select the best catalytic or IR detectors for your application. Let your General Monitors field applications engineers share their expertise to help you make the best sensing technology choice.





# GENERAL MONITORS

*Protection for life.*

26776 Simpatica Circle • Lake Forest, California 92630 • +1-949-581-4464 • Fax: +1-949-581-1151  
Visit us at [www.generalmonitors.com](http://www.generalmonitors.com) • e-mail: [sales@generalmonitors.com](mailto:sales@generalmonitors.com)

.....

9776 Whithorn Drive  
Houston, TX 77095  
USA  
Phone: +1-281-855-6000  
Fax: +1-281-855-3290  
email: [gmhou@generalmonitors.com](mailto:gmhou@generalmonitors.com)

Ballybrit Business Park  
Galway  
Republic of Ireland  
Phone: +353-91-751175  
Fax: +353-91-751317  
email: [postmaster@gmil.ie](mailto:postmaster@gmil.ie)

No. 2 Kallang Pudding Road  
#09-16 Mactech Building  
Singapore 349307  
Phone: +65-748-3488  
Fax: +65-748-1911  
email: [genmon@singnet.com.sg](mailto:genmon@singnet.com.sg)

P.O. Box 61209  
Jebel Ali  
Dubai, United Arab Emirates  
Phone: +971-4-8815751  
Fax: +971-4-8817927  
email: [gmme@emirates.net.ae](mailto:gmme@emirates.net.ae)

Heather Close  
Lyme Green Business Park  
Macclesfield, Cheshire  
United Kingdom SK11 0LR  
Phone: +44-1625-619583  
Fax: +44-1625-619098  
email: [info@generalmonitors.co.uk](mailto:info@generalmonitors.co.uk)