



EVOLUTION[®] 5200 and EVOLUTION[®] 5200HD² Thermal Imaging System

OPERATION AND INSTRUCTIONS

⚠ WARNING

THIS MANUAL MUST BE READ CAREFULLY BY ALL INDIVIDUALS WHO HAVE OR WILL HAVE THE RESPONSIBILITY FOR USING OR SERVICING THE PRODUCT. Like any piece of complex equipment, the unit will perform as designed only if it is used and maintained in accordance with the manufacturer's instructions. OTHERWISE IT COULD FAIL TO PERFORM AS DESIGNED AND RESULT IN SEVERE PERSONAL INJURY OR DEATH.

The warranties made by Mine Safety Appliances Company with respect to the product are voided if the product is not used and serviced in accordance with the instructions in this manual. Please protect yourself and others by following them. We encourage our customers to write or call regarding this equipment prior to use or for any additional information relative to use or repairs. During regular working hours, call 1-877-MSA-FIRE.

By order of the US Department of Commerce, in conjunction with the US Department of State and DOD, this Thermal Imaging Camera may not be resold, re-exported, transferred, or otherwise disposed of outside of the country named as the location of foreign end use, either in its original form or after being incorporated into other end items, without the prior written approval of the US Department of Commerce. Violation of this regulation may result in fine and/or imprisonment.

© MINE SAFETY APPLIANCES COMPANY 2009 - All Rights Reserved

This manual is available on the internet at www.msanet.com

Manufactured by

MSA NORTH AMERICA
P.O. Box 427, Pittsburgh, Pennsylvania 15230

(L) Rev 1



10075165

Table of Contents

BEFORE USE/DESCRIPTION	1
Figure 1. The Evolution 5200 TICand Evolution 5200HD2 TIC	1
INTRODUCTION	1
FEATURES AND BENEFITS	1
DESCRIPTION	1
ABOUT THE CAMERA	1
Figure 2.	2
Specifications	2
WARNINGS AND CAUTIONS	3
▲ WARNING	3
▲ CAUTION	3
LIMITATIONS	3
OPERATION	4
OPERATION	4
Getting Started	4
TURNING THE CAMERA ON AND OFF	4
Normal Mode	4
Figure 3. ON/OFF Button	4
Standby Mode	4
Turning the Camera OFF	4
USER INTERFACE- INDICATORS AND WARNINGS	4
2X Digital Zoom (Optional Feature on the Evolution 5200HD ² TIC)	4
Figure 4. Evolution 5200 and Evolution 5200HD2 TIC User Interface	5
On-Screen Indicators	5
LED Indicators	5
On-Screen Indicators	5
LED Indicators	5
▲ WARNING	6
Additional Indicators	6
Direct Video Connection	6
Figure 5. TIC with SMA to BNC Connector	6
BATTERY CARE AND INSTALLATION	7
RECHARGEABLE BATTERIES	7
BATTERY INSTALLATION AND CARE	7
BATTERY MAINTENANCE	7
STAND-ALONE BATTERY CHARGER	7
▲ WARNING	7
OPERATION	7
CHARGING THE BATTERY	7
Figure 6.	7

TIC ACCESSORIES9

TIC Configurations and Accessories9
Evolution 5200 and Evolution 5200HD² TIC Standard Components9
Other Options9
Carrying Attachments9
Display Sun Shroud9
Disposable Display Covers9
Custom Carrying Case9
Mounting Bracket (FIGURE 7)9
Tripod Mounting Adapter9
Tripod9
Reflective ID Label9
 Figure 7. Mounting Bracket9

**EVOLUTION 5000 SERIES UNIVERSAL
TRUCK-MOUNTED CHARGING SYSTEM OPERATION10**

Power Status LED Indicators10
Battery LED Indicators10
Figure 8. Universal Charger/Camera Engagement Sequence10
Figure 9.11
Figure 10.11
Figure 11.11

**EVOLUTION 5000 SERIES UNIVERSAL
TRUCK-MOUNTED CHARGING SYSTEM INSTALLATION12**

Operation12
Getting Started12
 ▲ WARNING12
What you will need:12
Installation Guidelines12
Mounting Hanging Channels12
Mounting the Universal Truck-Mounted Charger to Channels12
Electrical Connections13
Power Requirements13
 Electrical Specifications13
Installation13

THERMAL IMAGING CAMERA WARRANTY14

**EVOLUTION THERMAL IMAGING CAMERA
EXTENDED SERVICE APPLICATION15**

MAINTENANCE AND ADJUSTMENTS16

- GENERAL MAINTENANCE16
 - Cleaning16
 - ▲ WARNING16
- TROUBLESHOOTING THE TRUCK-MOUNTED CHARGING SYSTEM16
 - Troubleshooting Guidelines16
 - ▲ WARNING16
 - ▲ CAUTION16
- SERVICE17
 - Field Repairs and Maintenance17
 - Internal PCB Fuse Replacement17
 - Figure 12. Location of Power Cable, Phoenix Connector, and Internal Fuse ...17
- MSA FACTORY REPAIR & SERVICE POLICY CARD18

EVOLUTION 5000 SERIES TIC SPARE PARTS LIST19

BEFORE USE/DESCRIPTION



Figure 1. The Evolution 5200 TIC and Evolution 5200HD² TIC

INTRODUCTION

Congratulations on the purchase of your new MSA Evolution 5200 Thermal Imaging System! This hand-held unit provides advanced thermal imaging technology backed by years of MSA quality, dedication, and service.

The Evolution 5200 Series Thermal Imaging Camera (TIC) is designed to assist firefighters to see in low visibility conditions of smoke and darkness. This high definition thermal imaging camera provides the latest in available thermal imaging technology for the fire service.

FEATURES AND BENEFITS

The Evolution 5200 Series Thermal Imaging Camera (TIC) can be used to aid firefighting in scenarios such as:

- Search and rescue missions
- Initial size-up/Scene assessment
- Locating the seat of the fire
- Locating fire extension
- Identifying potential flashover situations
- Determining entry and ventilation points
- Hazmat situations
- Response vehicle navigation (darkness or heavy smoke)
- Preplanning/Fire code inspections
- Overhaul
- Assistance for law enforcement

DESCRIPTION

The Evolution 5200 and Evolution 5200HD² TICs are highly sophisticated pieces of electronic equipment. The unit was designed to withstand the firefighting conditions of heat, driving spray, and frequent impact normally seen by a firefighter. Extension beyond these demands may damage the camera and render it inoperable. It is not recommended that the camera run for extended periods in high-heat conditions.

The Evolution 5200 Series TICs are intended as an aid to fire and rescue operations in conditions of poor visibility created by smoke and darkness, and are not a replacement for standard firefighting techniques and precautions. Users must ensure that the fire department's standard operating procedures are followed while using the cameras.

ABOUT THE CAMERA

The Evolution 5200 Series TICs are as follows:

- equipped with a state-of-the-art 160 x 120 (Evolution 5200) or a state-of-the-art 320 x 240 (Evolution 5200HD²) microbolometer thermal detector to provide the clearest high-definition images available in fire and non-fire environments
- the Evolution 5200HD² features a 2X digital zoom feature, providing the user with magnified image information
- equipped with a large screen, high definition display to allow for multiple firefighters to view the action
- ergonomically designed for the firefighting environment
- available with desk top and truck mounted charging options
- designed with the most ergonomically correct balance, with the center of gravity located in the users hand
- dust and water-resistant to withstand short-term immersion in up to three feet of water in accordance with IP67 specifications
- available with multiple carrying and attachment options to suit user preferences - the Evolution 5200 TIC is a tool

- the Evolution 5200 TIC detects thermal energy radiated/generated from surrounding objects and converts this energy into a visual image.
 - Hot objects appear **white**.
 - Cold objects appear **black**.



Figure 2.

Specifications

CONSTRUCTION		Flame retardant (material passes simulated NFPA direct flame exposure test). IP67 [withstands immersion to 3 feet (1meter)]
APPROXIMATE DIMENSIONS	HEIGHT	10.8 inches (275 mm)
	WIDTH	8.1 inches (205 mm)
	LENGTH	4.4 inches (112 mm)
SENSOR		Uncooled VOX microbolometer
ARRAY SIZE	EVOLUTION 5200	160 X 120
	EVOLUTION 5200HD²	320 X 240
WEIGHT		2.8 lbs.
POWER SOURCE		Rechargeable LiIon batteries
POWER USAGE	AT 72°F (22°C)	Less than 6.0 W nominal
OPERATING TIME	1 Li Ion PACK	2 hours at nominal 72°F (22°C)
FIELD OF VIEW	EVOLUTION 5200	55° H; 44° V
	EVOLUTION 5200HD²	36° H; 27° V
NET EQUIVALENT TEMPERATURE DIFFERENCE	HIGH SENSITIVITY	.065°C, 65 mK
	LOW SENSITIVITY	.240°C, 240 mK
VIDEO OUTPUT		RS-170

This device complies with part 15 of the FCC Rules. Operation is subject to the following two conditions: (1) This device may not cause harmful interference, and (2) this device must accept any interference received, including interference that may cause undesired operation.

WARNINGS AND CAUTIONS

⚠ WARNING

1. The user must be trained and thoroughly familiar with the proper operation and limitations of the thermal imaging system prior to use. Use in controlled live-burn exercises is suggested before using the equipment in actual emergency situations. Improper use of the equipment in a hazardous atmosphere could result in serious personal injury or death.

2. Do not rely on the thermal imaging system as the sole means of navigation or deviate from standard fire-fighting navigational practices during use. Although the system provides an image in dark and smoky environments, the user may become disoriented or lost in such environments if the system becomes inoperative.

Most electronic devices will cease to operate at certain high temperature extremes. Tests on the Evolution 5200 and Evolution 5200HD² TIC indicate that they will provide an acceptable image when subjected to an ambient temperature of approximately 120°C (248°F) for 20 minutes. Exposure to conditions exceeding these will result in deterioration and loss of image.

3. Thermal energy is not transmitted through glass or underwater and may be reflected off of smooth surfaces. Disorientation may occur if the user is unaware of these properties.
4. This thermal imaging system is not rated as "Intrinsically Safe." Do not use the system in environments or atmospheres where static or sparks may cause an explosion.
5. Before entering a hostile environment, test the thermal imaging system as specified in the instructions to ensure that it is functional. After each use, inspect the system to determine if servicing is required.
6. Exposure to high temperature environments for an extended period of time may cause degradation or loss of thermal image. Avoid heat saturation or over exposure of the equipment. If degradation of the thermal image is observed, immediately remove the equipment from the high heat environment and allow it to cool until the thermal image returns to normal; otherwise, the system may become inoperative.

7. Replacement batteries must exactly match the ratings and configuration of those supplied with the equipment. Use of unapproved batteries may render the system inoperative.
8. Do not remove the thermal imaging camera cover or casing as the system operates on high voltage. Only authorized personnel may service the unit.

FAILURE TO FOLLOW THE ABOVE WARNINGS CAN RESULT IN SERIOUS PERSONAL INJURY OR DEATH.

⚠ CAUTION

1. Ensure battery is fully charged before use. If not fully charged, the system will not operate for the specified amount of time. Monitor battery level during use and immediately exit the hazardous area when a low battery warning is observed.
2. Electromagnetic radiation (radio transmissions) may cause interference. Minimize nearby radio transmissions if excessive interference occurs.
3. To avoid lens fogging, the user may coat the lenses and view finder with MSA anti-fog material (MSA P/N 13016).
4. Do not point the thermal imaging camera directly at the sun; otherwise, damage to the detector may occur.
5. Do not drop the thermal imaging camera. Although the camera is designed to withstand normal impacts that occur in fire service, such impacts may alter the focus or damage the unit.

FAILURE TO FOLLOW THE ABOVE CAUTIONS CAN RESULT IN PERSONAL INJURY OR EQUIPMENT DAMAGE.

LIMITATIONS

1. Although the Evolution 5200 and Evolution 5200HD² TICs are IP67 waterproof, these systems do not provide underwater thermal images.
2. The Evolution 5200 and Evolution 5200HD² TICs do not provide images through glass, water, or shiny objects; these surfaces act like mirrors to the system.
3. The Evolution 5200 and Evolution 5200HD² TICs do not improve impaired vision. Users with impaired vision should continue to use ophthalmic devices while using the systems.

OPERATION

OPERATION

Getting Started

The rechargeable batteries supplied with the Evolution 5200 and Evolution 5200HD² TICs must be fully charged before use. Also, periodically check and replace the battery in an actively-used imager.

- See "Battery Care and Installation" later in this manual.

TURNING THE CAMERA ON AND OFF

Normal Mode

1. To turn the camera ON, press the POWER (green) button on the TIC handle (see FIGURE 3) and hold for approximately one second.



Figure 3. ON/OFF Button

2. Wait approximately five seconds for the infrared sensor electronics to self-test.
 - The green POWER LED (located near the display) lights.
 - After several seconds, the thermal image appears on the screen.
3. Verify the camera is functioning by aiming at an object or person until the thermal image appears in the camera viewer.
 - The thermal imaging camera is now ready for use.

NOTE: The Evolution 5200 or Evolution 5200HD² POWER button has a

momentary pushbutton switch that requires deliberate, one-second activation to activate. Rapid repeated depression of the POWER button may cause the TIC start-up software to lock, and a picture will not display (LEDs may still activate). If this condition occurs, simply turn the TIC OFF and back ON using slow, deliberate button presses.

Standby Mode

To conserve battery consumption, the camera is equipped with a Standby Mode feature.

4. To activate, press the POWER button until:
 - The display shuts OFF.
 - The system STATUS LED begins to flash green.
5. To return to Normal Mode from Standby Mode, press the POWER (green) button until:
 - The display immediately reactivates without warm-up time.
 - The system STATUS LED turns to solid green.

Turning the Camera OFF

6. To turn the camera OFF, press and hold the green POWER button for four seconds.
 - As a safety feature to avoid inadvertent power-OFFs, the green POWER button must be held for four seconds to turn OFF the camera.
 - The green STATUS LED flashes during the power-off countdown to confirm effective button press.
 - When all LED indicators shut OFF, the user may release the green POWER button.
 - The camera is now OFF.

USER INTERFACE-INDICATORS AND WARNINGS

2X Digital Zoom (Optional Feature on the Evolution 5200HD² TIC)

To activate, press the POWER button until:

- The 2X indicator appears on the camera's display (above the green system status LED).

To return to Normal Mode from 2X Digital Zoom

Mode, press the POWER (green) button until:

- The display immediately returns to the standard view and the 2X indicator is no longer present.

NOTE: The 2X Digital feature replaces the Standby-Mode feature on the Evolution 5200HD² TIC.

The Evolution 5200 and Evolution 5200HD² TIC come standard with five LED Indicators for System Status, Battery Life and Overtemp status. When the TIC is turned ON, all LEDs "flash" for two to three seconds; then, the thermal picture appears. When the TIC is turned OFF, all LEDs are darkened. Also, the TIC has on-screen indicators for low sensitivity, shutter and optional quick-temp (FIGURE 4).

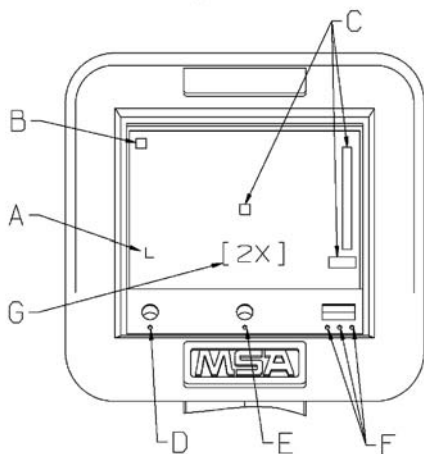

Figure 4. Evolution 5200 and Evolution 5200HD² TIC User Interface

On-Screen Indicators

- A Low sensitivity firefighting mode indicator
- B Shutter indicator
- C Optional Quick - Temp Indicator and Digital Temperature Measurement

LED Indicators

- D Over - Temperature Warning
- E System Status Indicator
- F Battery Status Indicators.

On-Screen Indicators

A - Low Sensitivity Mode Indicator -

An on-screen sensitivity indicator ("L") informs the user when the camera is in the low sensitivity mode.

- This mode occurs when the thermal imager senses an environment above 160°C or 320°F.
- Dynamic Range is extended while in this mode to provide greater image details of the surroundings.

In high-heat conditions, the TIC will automatically enter the Low Sensitivity mode. While in Low Sensitivity mode, the TIC's dynamic range is extended, thereby allowing the user to make better distinction of objects and people within a higher temperature range. When the Evolution 5200 TIC is in Low Sensitivity mode, the letter "L" appears in the lower left corner of the display.

B - Shutter Indicator -

An on-screen indicator that tells the user when the TIC is shuttering appears as a green square in the upper left corner of the display.

While the TIC is in operation, it is periodically necessary for the TIC to refresh the focal plane in order to operate properly. This occurs via an internal shutter mechanism. When the TIC shutters, the image on the display temporarily freezes for about one second. Shuttering can occur more frequently in higher heat conditions. This is normal for all microbolometer - based TICs.

C - Optional Quick-Temp Indicator -

On-screen operating Quick Temp spotter and vertical bar gauge spans temperatures from 0°F (0°C) to 300°F (150°C) in High Sensitivity mode and 0°F (0°C) to 1000°F (500°C) in Low Sensitivity mode for objects located in the spotter. The digital temperature feature displays the approximate numeric value of the temperature of objects located in the spotter.

G - Optional 2X Digital Zoom Indicator on the Evolution 5200 TIC -

An on-screen indicator that tells the user when the TIC display is in the Zoom mode, appears as [2X] in the lower center of the display.

LED Indicators

D - Over Temperature Warning -

Warning activates when the system electronics approach maximum recommended operating temperature limits.

- Not lit indicates system is within operational thermal limits
- Flashing Red indicates the TIC has exceeded recommended operational thermal limits.

▲ WARNING

Most electronic devices will cease to operate at certain high temperature extremes. Tests on the Evolution 5200 and Evolution 5200HD² TICs indicate that they will provide an acceptable image when subjected to an ambient temperature of approximately 120°C (248°F) for about ten minutes. Exposure to conditions exceeding these will result in deterioration and loss of image.

E - System Status Indicator -

A single LED shows the operational status of the TIC.

- Green indicates the TIC is ON and fully operational
- Flashing Green indicates the TIC is ON and in power-saving Standby mode.

F - Battery Status Indicator -

Battery capacity is shown by a row of three LEDs: one green, one yellow, and one red. Only one of the three battery status indicators will be illuminated at any one time.

- Green indicates full or nearly full battery capacity
- Yellow indicates marginal battery capacity
- Red indicates battery warning and nominally 15 minutes of battery life remaining
- Flashing Red indicates battery shutdown is imminent (about one minute of warning time).

Additional Indicators

Optional Heat Seeker Plus Indicator -

The optional Heat Seeker Plus indicator adds shades of color to objects in the scene reaching high temperatures in both High and Low Sense mode. The shades of color allow for some details of the object to be seen for easier identification.

In High Sensitivity mode:

- The color of objects reaching 275°F (135°C) will be yellow, starting with light shades changing to darker shades, and then moving to light and dark shades of orange as the temperature increases.
- Once objects reach a temperature of 297°F (147°C), they become red starting with light shades changing to darker shades up to a temperature of 320°F (160°C).

In Low Sensitivity mode:

- The color of objects reaching 842°F (450°C) will be yellow, starting with light shades changing to darker shades, and then moving to light and dark shades of orange as the temperature increases.
- Once objects reach a temperature of 914°F (490°C), they become red, starting with light shades changing to darker shades up to a temperature of 1040°F (560°C).

System Fault Indicator -

All five LEDs will flash if a system fault is detected. The TIC's internal computer runs a self-diagnostic program. If a problem with the internal component is detected, a fault will be signaled and the LEDs will flash.

Direct Video Connection

If you plan to use the TIC for viewing or recording direct video, the Evolution 5200 and Evolution 5200HD² TICs are equipped with an SMA-type video out connector located below the display, next to the handle. Also included is an adapter cable to a BNC connection (FIGURE 5).



Figure 5. TIC with SMA to BNC Connector

If you plan to use the video out capability, attach the SMA connector end and rout the adapter cable to and through the front handle. The unit can then be quickly attached to a video display using a BNC connection.

BATTERY CARE AND INSTALLATION

RECHARGEABLE BATTERIES

The Evolution 5200 and Evolution 5200HD² TICs run on one Lithium Ion battery; one battery is required for TIC operation.

BATTERY INSTALLATION AND CARE

1. Place the unit on a clean, non-abrasive surface and lean the unit forward.
2. Unhook the battery latch and open the battery compartment.
3. Place the battery inside the battery compartment with the battery logo and arrow facing right and pointing toward the top of the TIC.
4. Close and latch the battery compartment.

BATTERY MAINTENANCE

After each use, inspect:

- battery contacts for damage
- batteries for damage or leakage
- to ensure battery charger is functioning properly by:
 - placing battery into the charger
 - checking that the battery charger LEDs react accordingly.

NOTE: Batteries not passing this inspection must be removed from service until the proper repairs are made.

STAND-ALONE BATTERY CHARGER

⚠ WARNING

This charging system is not rated as "intrinsically safe." Do not use the system in environments or atmospheres where static or spark may cause an explosion.

Do not remove the outer housing of the Charger. Only authorized personnel may service the unit.

The Charger must only be used for charging Evolution rechargeable Lithium Ion Battery Packs.

Do not use damaged chargers.

Do not attempt to charge damaged packs.

Do not use the charger outdoors.

FAILURE TO FOLLOW THE ABOVE WARNING CAN RESULT IN SERIOUS PERSONAL INJURY OR DEATH.

OPERATION

Choose the proper adapter cord power source to be used.

1. **For standard AC operation:** Plug the DC plug of the AC/DC Adapter into the charger and plug the AC Adapter into any standard 110-VAC outlet.
2. **For DC Power Adapter operation:** Plug the DC Power Adapter Cord into the charger and plug the other end into any DC 12-V power source that offers a cigarette-lighter type socket.

CHARGING THE BATTERY



Figure 6.

1. Connect the unit with either AC/DC Power Adapter or DC Car Power Adapter.
2. Place the battery into the unit.
 - **StandBy Mode:**
 - Without any battery installed, the charger will flash the LED marked MED, indicating that the charger is standing by and waiting for a battery to be connected.
 - **Phase 1 - Initial Charge:**
 - All three LEDs flash in sequence from MED (left) to MAX (right)
 - If the battery is low, this will be the first charge phase

- With high capacity batteries, this phase can sometimes be the longest of the three phases
- With some low capacity batteries and batteries reaching the end of their life, this phase can be very short.

NOTE: When a battery is first connected, the LEDs may instantly indicate MED, HI and MAX charge, depending on the charge status of the battery. The process will continue normally from that point forward.

NOTE: It is normal for the charger, AC adapter, or the battery to become warm during charging.

- **Phase 2 - MED Charge:**
 - MED LED is ON continuously and other LEDs are flashing in sequence
 - At this point, the battery is typically about 50% charged.
- **Phase 3 - HI Charge:**
 - The MED and HI LEDs are ON and the MAX LED is flashing
 - At this point, the battery is typically about 70% charged.

- **Phase 4 - MAX Charge:**
 - All three LEDs are ON at the same time
 - Charging is complete and the battery is fully charged
 - It is recommended to remove the battery at this time.

3. Remove the battery from the unit.

- The battery is now ready for use.

NOTE: **Error Condition - Charge Terminated** - If the battery is removed before a complete charge is reached, the charger continues indicating the last complete charging phase for up to one minute. After that time, an "Error" indication appears on the LEDs (shown by the MED and MAX LEDs coming ON together while the HI LED is OFF).

The Error Condition is also indicated if the charger senses any problem with the battery being charged. To reset the Error Condition, unplug the charger from the power adapter for a few seconds; then, reconnect the charger to the power adapter. If the Error occurs again, there may be a defect in the battery that prevents safe charging.

TIC ACCESSORIES

TIC Configurations and Accessories

The Evolution 5200 or the Evolution 5200HD² TIC can be purchased as a complete kit with accessories or can be custom configured to your requirements under the Assemble to Order (ATO) System. There are several part numbered kits to choose from. Please see the Evolution 5200 or Evolution 5200HD² Brochure for complete ordering information.

Evolution 5200 and Evolution 5200HD² TIC Standard Components

All Evolution TICs come standard with the following items:

- Thermal Imaging Camera
- One Rechargeable Lithium Ion Battery
- Caribiner Attachment
- Standard Universal Charger Kit with Cigarette Lighter Adapter or Truck Mounted charger
- Care and Use Video
- SMA Video Out Connector
- Instruction Manual.

The Evolution 5200 and Evolution 5200HD² TIC can be ordered as standard kit part numbers or as Assemble to Order. See ordering information.

Other Options

Carrying Attachments

The Evolution 5200 and 5200HD² Thermal Imaging Cameras (TICs) come standard with a caribiner attachment. Additionally, users can choose to purchase any one of three optional carrying attachments:

Wrist Strap/Bunker Clip - Attaches to the TIC and includes a clip for securing the TIC to bunker gear while not in use.

Shoulder strap - Attaches to the TIC to allow for easy carriage of the camera while not in use.

Retractable Lanyard - Attaches to the TIC to allow for easy carriage and quick use of the camera while attached to the user's belt or gear. Lanyard easily retracts the camera back into place when not in use.

Display Sun Shroud

Display Shroud allows for crisp/clear viewing of the LCD screen while in bright sunlight.

NOTE: It is NOT recommended that reflective trim pieces be placed on the main camera housing if the TIC is used with a truck-mounted charger, as it may interfere with making adequate contact.

Disposable Display Covers

A package of three Disposable Display Covers provides replaceable protection of the 3.5" LCD.

Custom Carrying Case

The Durable Carrying Case allows for storage and transport of the TIC, batteries, charger, and carrying attachments.

Mounting Bracket (FIGURE 7)

The Non-Charging Mounting Bracket enables convenient storage of the Evolution 5200 TIC.

Tripod Mounting Adapter

The Tripod Mounting Adapter allows for mounting of the TIC onto any standard tripod.

Tripod

The Tripod allows for stationary viewing of the thermal imaging camera. The Tripod must be used with the Tripod Adapter.

Reflective ID Label

The Reflective ID Label Kit includes one sheet of colored accent labels designed to personalize the TIC. Labels fit on the top and sides of the TIC and may be written on to further assist in TIC identification.



Figure 7. Mounting Bracket

EVOLUTION 5000 SERIES UNIVERSAL TRUCK-MOUNTED CHARGING SYSTEM OPERATION

To charge the TIC and spare batteries using the Evolution 5000 Series Truck-Mounted Charging System make sure the TIC charging pins and cradle are clean and free from debris (FIGURE 8).

1. Place the handle of the TIC on the alignment pin, with the display facing inward. Pivot the camera down until the charging connections make contact; secure the unit with the straps on the charging cradle.
2. If charging a spare battery, place the battery into the slot provided and secure it with the rubber retainer.

The power LED indicator should always remain green when the power source is ON and properly connected. When the Truck-Mounted Charging System is correctly installed, the status indicators will light as follows:

Power Status LED Indicators

OFF	System Fault
GREEN	Power On/ System Operational

Any LED indication other than those listed indicates faulty operation and the unit must be returned to MSA for service.

Battery LED Indicators

OFF	No Battery Installed
GREEN	Charge Completed
FAST BLINKING GREEN	Charging
SLOW BLINKING GREEN	Charge Pending
RED	Fault

Any LED indication other than those listed indicates faulty operation and the unit must be returned to MSA for service.



Figure 8.
Universal Charger/Camera
Engagement Sequence

NOTE: For optimal performance, the battery charger should be operated at temperatures between 50 to 85° F (10 to 29° C). Charging batteries outside this temperature range may result in a charging error and/or premature battery degradation. Charging batteries in environments greater than 100° F (38° C) may result in premature termination of charge.

The charging cycle takes approximately 2-1/2 hours to completely charge a single battery or five hours when charging two completely discharged batteries.

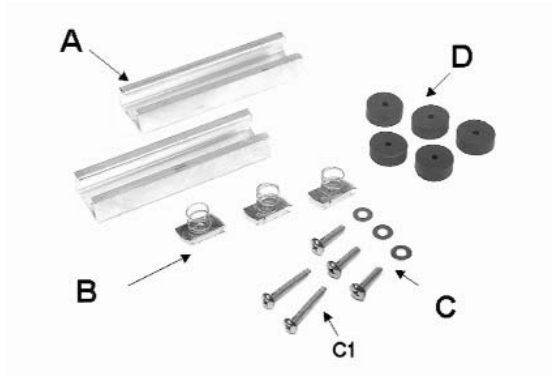

Figure 9.



Figure 10.



Figure 11.

EVOLUTION 5000 SERIES UNIVERSAL TRUCK-MOUNTED CHARGING SYSTEM INSTALLATION

Operation

Getting Started

The Evolution 5000 Series Universal Truck-Mounted Charging System must be correctly installed before use. Read all installation instructions thoroughly before starting actual installation.

⚠ WARNING

Carefully follow all instructions provided with this charger. This charger will perform as designed only if installed, used, and maintained properly; otherwise, it may fail to operate properly and result in serious personal injury or death.

Use eyewear or face protection to avoid eye injury during installation; failure to do so may result in serious personal injury.

What you will need:

- Electric drill
- #7 (.201) drill bit, 9/32 (0.281) drill bit
- 1/4-20 tap
- #2 Phillips head screwdriver
- Stainless steel 1/4- 20 bolts (4)
- 5-amp in-line fuse
- Master ON/OFF switch
- Strain relief bushing for power supply cable
- Installation hardware kit (provided).

Installation Guidelines

Select a large flat surface area for mounting that allows easy access for Evolution 5200 TIC storage and adequate cable length for electrical connections. Take care to install the charger in an area protected from direct water spray and extreme temperature conditions.

Mounting Hanging Channels

1. Drill two holes in both Unistrut channels (A in FIGURE 8), using a 9/32 (.281) drill.
 - Drill mounting holes, 1-1/2 inches in from outside edges of channels.
2. Place top channel on the cab wall, approximately four inches away from overhead obstructions.
3. Using a Unistrut channel as a template, drill two holes into cab wall with a #7 (.201) drill.
4. Tap both holes for 1/4-20 mounting bolts.
5. Position bottom channel on cab wall, 6-1/2 inches away from center of top channel.
6. Repeat steps 3 and 4 to mount bottom channel.
7. Bolt both channels in-place with stainless steel 1/4-20 bolts.

Mounting the Universal Truck-Mounted Charger to Channels

1. Slide Unistrut spring nut (B in FIGURE 8) into channel and rotate 90° to seat nut in channel V-groove. One nut is required for the top channel and two for the bottom channel.
2. Place the stainless steel bolts (C in FIGURE 8) through the mounting holes molded into the charger.
3. Place the neoprene rubber washer (D in FIGURE 8) over the bolt, align bolt with spring nut and tighten.

NOTE: If mounting the charger vertically, use the two longer stainless steel bolts on the bottom and add a second neoprene washer to each of the bottom two bolts.

Electrical Connections

Power Requirements

The Truck-Mounted Charging System can consume enough current to eventually fully drain the vehicle's battery, if the vehicle stands for longer than a 12-hour period without supplemental battery charging.

Therefore, it is recommended that the charger be installed using any master ON/OFF switch where power comes directly from the battery, supplemental charger or connected to AC power via a shoreline when the vehicle is stored.

Electrical Specifications

INPUT VOLTAGE RANGE	12.5 to 26.0 VDC (Fused at source)
----------------------------	------------------------------------

INPUT CURRENT	Less than 2.0 Amps DC
----------------------	-----------------------

NORMAL BATTERY CHARGE TIME	2.5 Hours
-----------------------------------	-----------

Installation

1. Connect the positive lead (red) on the prepared wire end of the power supply line to a fused, in-line connection with a master switch. Connect to the switched side of ignition or power source.
2. Connect the negative lead (black) of power supply line to a confirmed ground.
3. With power source ON, confirm that the power LED light is GREEN. If any other result occurs, see "Troubleshooting Guidelines" in the "Maintenance, Troubleshooting and Service" section of this manual.



Thermal Imaging Camera Warranty

1. Express Warranty

MSA warrants that this product and its accessories are free from mechanical defects or faulty workmanship as prescribed in the chart below, provided they have been installed, used, and maintained in accordance with the instructions and/or recommendations contained in the instructions delivered with the equipment. MSA shall be released from all obligations under this warranty in the event repairs or modifications are made by persons other than its own or authorized service personnel. No agent, employee or representative of MSA has any authority to bind MSA to any affirmation, representation or warranty concerning the goods sold, and unless an affirmation, representation or warranty made by an agent, employee or representative is specifically included within the written agreement for the goods sold it shall not be enforceable by the original end-user. MSA makes no warranty concerning components or accessories not manufactured by MSA, but will pass on to the original end-user all warranties of manufacturers of such components. **THIS WARRANTY IS IN LIEU OF ALL OTHER WARRANTIES, EXPRESS, IMPLIED OR STATUTORY, AND IS STRICTLY LIMITED TO THE TERMS HEREOF. MSA SPECIFICALLY DISCLAIMS ANY WARRANTY OF MERCHANTABILITY OR OF FITNESS FOR A PARTICULAR PURPOSE.**

Products covered by this Express Warranty include the Evolution 5200, Evolution 5200HD, Evolution 5600, Evolution 5800 and ThermalTrac Thermal Imaging Cameras (TICs). All warranty periods referenced below are from the date of sale to the original end-user unless otherwise noted.

Component	Warranty Period	Maintenance
Camera Core	2 years	MSA requires that the TIC and accessories be installed, used, and/or maintained as specified in the product instructions. All TICs and accessories sent in for warranty repair will be inspected for signs of excessive rough handling and operation significantly beyond specifications in the instructions. The warranty coverage is for material defects and/or faulty workmanship only. Repair and labor required for normal wear and tear are not covered under the warranty and are the responsibility of the original end-user.
Housing and all non-camera core components	1 year	
Truck/Wall/Desktop Chargers, External Receivers and Transmission Equipment	1 year	
Replacement Parts / Repairs (non-warranty)	90 Days from date of repair	
Factory Upgrades	90 Days or remainder of existing warranty, whichever is longer	

2. Extended Service

MSA offers an Extended Service contract for TICs at the customer's request. Details are listed on the reverse of this page. Contact MSA Fire Service Customer Service (1-800-MSA-2222) for additional information and arrangements.

3. Loaner Cameras

MSA does support a loaner camera program for customers when deemed necessary (extended repair time, critical equipment replacement, etc.). The loaner camera will not necessarily be the exact model that it is replacing. Contact MSA Fire Service Customer Service (1-800-MSA-2222) for additional information and arrangements.

4. Exclusive Remedy—It is expressly agreed that the Original end-user's sole and exclusive remedy for breach of the above warranty, for any tortious conduct of MSA, or for any other cause of action, shall be the repair and/or replacement, at MSA's option, of any equipment or parts thereof, that after examination by MSA are proven to be defective. Replacement equipment and/or parts will be provided at no cost to the Original end-user, F.O.B. Original end-user's named place of destination. Failure of MSA to successfully repair any nonconforming product shall not cause the remedy established hereby to fail of its essential purpose.

5. Exclusion of Consequential Damages—Original end-user specifically understands and agrees that under no circumstances will MSA be liable to Original end-user for economic, special, incidental, or consequential damages or losses of any kind whatsoever, including but not limited to, loss of anticipated profits and any other loss caused by reason of the non-operation of the goods. This exclusion is applicable to claims for breach of warranty, tortious conduct or any other cause of action against MSA

Note: This Bulletin contains only a general description of the products shown. While uses and performance capabilities are described, under no circumstances shall the products be used by untrained or unqualified individuals and not until the product instructions including any warnings or cautions provided have been thoroughly read and understood. Only they contain the complete and detailed information concerning proper use and care of these products.



Corporate Headquarters
P.O. Box 426, Pittsburgh, PA 15230 USA
Phone 412-967-3000
www.MSAFire.com

Fire Service Customer Service
Phone 1-877-MSA-FIRE
Fax 1-800-967-0398

MSA Canada
Phone 1-800-MSA-2222
Fax 905-238-4151

MSA Mexico
Phone (52) 55 2122 5770
Fax (52) 55 5359 4330

MSA International
Phone 412-967-3354
Fax 412-967-3451

Offices and representatives worldwide
For further information:

10048052, Rev 8
ID 3400-41-MC / July 2008
© MSA 2008 Printed in U.S.A.



Evolution® Thermal Imaging Camera Extended Service Application

Submit this completed form to:

MSA
Attention: Fire Service Customer Service Center
Evolution TIC Extended Service Program
PO Box 426
Pittsburgh, PA 15230-0426
(or Fax 1-412-967-3053)

One application must be submitted for EACH Evolution TIC. Phone 1-800-MSA-2222 for assistance in completing this form.

1. Extended warranty requests **MUST** be exercised within the first 6 months from the date of manufacture. The last three characters (MYY, or "month-year-year") of the TIC's serial number (located in the battery compartment of the TIC) will dictate this time-frame (XX-XXXX-MYY).
2. Extended warranty will lengthen warranty coverage up to 12 months after the standard warranty would expire.
(Total coverage for the camera core would be 36 months; total coverage for the rest of the camera would be 24 months.)
3. Extended warranty and standard warranty both begin from the date of purchase by the end user.
4. This Extended Warranty program applies only to MSA Evolution Thermal Imaging Cameras. Consumables, battery chargers and accessories are not covered.

Please print legibly

Company/Department Name _____

Contact Name _____ **Title** _____

Phone _____ **Fax** _____ **Email** _____

MAILING ADDRESS:

SHIPPING ADDRESS:

Street/PO Box _____

Street/PO Box _____

City _____

City _____

State/Province _____ **Zip/PC** _____

State/Province _____ **Zip/PC** _____

Please extend the service on the following MSA Evolution Thermal Imaging Camera:

Evolution 5200 TIC Evolution 5200HD2/ThermalTrac TIC Evolution 5600 TIC Evolution 5800

Serial # (located in TIC battery compartment) _____

This TIC was purchased from (insert MSA distributor company name) _____ on our

Purchase Order # _____ dated _____ Distributor Invoice # _____ dated _____

Purchase Order # _____ enclosed

Print Name _____

Authorized Signature _____

1 year extended service - US \$1000

MAINTENANCE AND ADJUSTMENTS

GENERAL MAINTENANCE

After each use, inspect:

- the Evolution 5200 TIC for structural, heat and/or chemical damage
- the mechanical hardware to ensure no screws are loose
- all lenses for heat damage, chemical damage, cracks and breaks
- to ensure that all warning labels are intact
- battery - see "Battery Care and Installation"

NOTE: Thermal Imaging Cameras not meeting the above inspection must be removed from service until the proper repairs are made by MSA.

- charger and TIC LEDs for proper indication that the system is operating properly.

Cleaning

After each use, clean all external surfaces (case, base, visor, lens, window and straps) by wiping with a solution of mild detergent and warm water. Dry with a soft, lint-free cloth, to avoid scratching the optical surfaces.

Periodically check connector terminals, video socket, ON/OFF switch, locking latch and hinge for contamination. Clean with a soft, lint-free cloth.

⚠ WARNING

Do not remove the thermal imaging camera cover or casing as the system operates on high voltage. Only authorized personnel may service the unit.

FAILURE TO FOLLOW THE ABOVE WARNING CAN RESULT IN SERIOUS PERSONAL INJURY OR DEATH.

TROUBLESHOOTING THE TRUCK-MOUNTED CHARGING SYSTEM

Troubleshooting Guidelines

SYMPTOM	PROBLEM/SOLUTION
NO LEDs LIT	Check power connections. Is power available? Is the positive power lead connected to the positive terminal? External in-line fuse blown. Replace fuse Internal fuse blown. Replace fuse.
POWER LED STATUS IS GREEN & CAMERA BATTERY LED DOES NOT LIGHT WHEN CAMERA IS PLACED IN CHARGER	No batteries installed in the camera. Verify that there are good batteries in the camera Bad connection to the camera. Make sure charger contacts are clean and unbent. A small amount of contact cleaner, such as WD-40, can be used to clean charger and camera charging contacts. Reseat firmly to ensure connection .
POWER LED STATUS IS GREEN AND EXTERNAL BATTERY LED DOES NOT LIGHT WHEN BATTERY IS PLACED IN CHARGER	Inspect battery contacts for dirt, corrosion or damage. Clean contacts or replace battery. Inspect the contacts of the battery charger. Verify they are clean, unbent, and move down and spring back.
BATTERIES DO NOT FULLY CHARGE	Out of operating temperature range. Check that temperature of environment and /or batteries is within recommended operating range Power source is noisy. Ensure power hookup cable is connected to a clean source without excessive voltage spikes.

⚠ WARNING

It is possible that charge can be terminated abnormally. While this condition is rare, it can occur because of external in-band noise that may reach the charger electronics. In the unlikely event that charge is falsely terminated because of noise, the battery may not fully charge. Always use the camera battery gauge as an indicator of battery condition.

⚠ CAUTION

Do not use solvents or paint thinners to clean the Thermal Imager; otherwise, the protective case may become degraded.

SERVICE

If your Evolution 5200 Thermal Imaging Camera (TIC) is in need of service or repair, please contact the MSA Service Center at 1-877-MSA-FIRE.

Describe the problem to the Representative as completely as possible.

1. Verify with your Representative that the product should be returned to MSA.
 2. Before returning the product, decontaminate and clean your Thermal Imaging Camera to remove any hazardous materials that may have settled on the product during use.
- Laws and/or shipping regulations prohibit the shipment of hazardous or contaminated materials.
 - Products suspected of contamination will be professionally decontaminated at the customer's expense before servicing.
 - Ship returned products (including those under warranty) with pre-paid transportation charges; MSA cannot accept returned goods on a freight-collect basis.

Field Repairs and Maintenance

NOTE: Only remove the Truck-Mounted Charging System's back cover in an ESD-protected area with personal grounding system (e.g., grounded wrist strap).

Internal PCB Fuse Replacement

Power LED will not light and other troubleshooting guidelines do not resolve the problem.

1. Remove charger from mounting brackets. Using a screwdriver, remove the three retaining clips from the plastic bosses and remove the back cover.
2. Disconnect the power hookup cable by disconnecting the Phoenix connector from the plug-in receptacle on the upper right side of the printed circuit board panel.
3. The internal printed circuit board fuse is located next to the Phoenix connector on the circuit board. Remove the fuse using the plastic, nonconductive tweezers and replace it with a new fuse (P/N 10041101, package of five)
4. Reconnect the power hook-up cable to the Phoenix connector and replace the back cover. Secure the cover with the retaining clips and bolt it back to the mounting brackets.

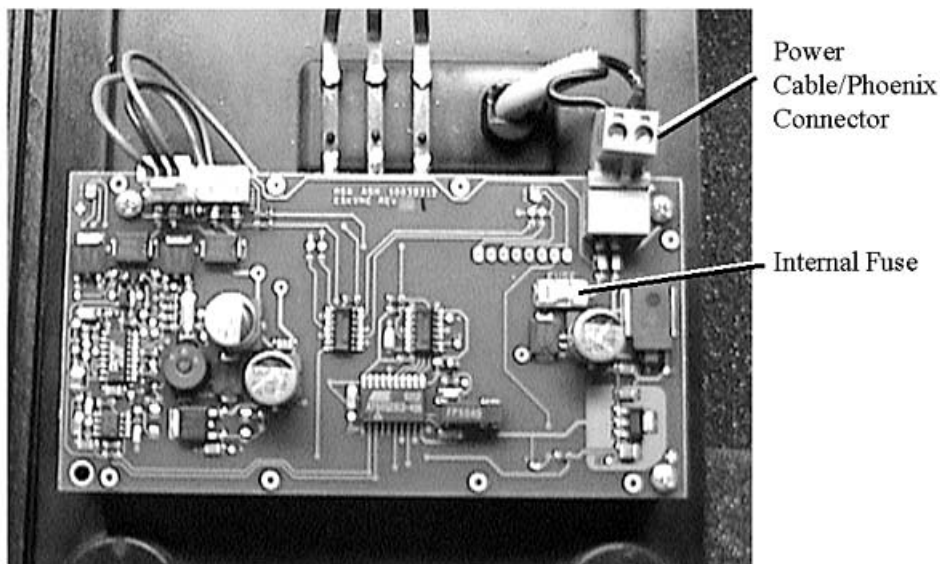

Figure 12. Location of Power Cable, Phoenix Connector, and Internal Fuse

MSA FACTORY REPAIR & SERVICE POLICY CARD

To help process your repair requests, please provide the following information:

Please complete this form in full. Thank you.

Customer's Billing Address:		Customer's Shipping Address:	
Company Name:		Company Name:	
Street/P.O. Box:		Street Address:	
City/State/Zip:		City/State/Zip:	
Contact Name:		Phone Number:	
Product Name:		Fax Number:	
Model Number:		Your PO Number	
To save time - please check ONE of these alternatives:		Description of problem/special instructions:	
<input type="checkbox"/>	Repair and return (PO Number must be provided)		
<input type="checkbox"/>	Estimate required before repair		
<input type="checkbox"/>	Warranty Claim (Orig. MSA Invoice No. _____)		
<input type="checkbox"/>	Medical RA No. _____		

Authorized by:	Title:	Date: - -
----------------	--------	-----------

FOR CALIBRATION OR REPAIR, PLEASE PROVIDE THE INFORMATION REQUESTED ABOVE. PLEASE USE A SEPARATE SHEET FOR EACH INSTRUMENT.

EVOLUTION 5000 SERIES TIC SPARE PARTS LIST

PART NUMBER	SPARE PART
10041100	Charger 110 VAC with Cigarette Lighter Adapter
10038412	Lithium Ion Battery
10067565	Evolution 5000 Series Universal Truck-Mounted Charging System
10039516	Wrist Strap
10039515	Shoulder Strap
10040226	Retractable Lanyard
10040005	Caribiner
10039603	Sun Shroud
10038970	Disposable Display Covers
10067707	Non-Charging Mounting Bracket
10040223	Carrying Case
10040229	Tripod Mount
10018996	Tripod Kit
10040004	Video Out Cable SMA to BNC
10020290	10 Foot Auxiliary BNC Cable
10059512	Instruction Manual
10041101	Fuses, Truck-Mounted Charger (package of five)
10040222	Evolution 5000 Series Mounting Kit
10062184	Label Kit, Reflective ID