

Dyna-Glide®

CLIMBING PROTECTION SYSTEM CATALOG

volume 5



Dyna-Glide® Climbing Protection Systems from MSA

A Few Words about This Catalog—

At Mine Safety Appliances Company, we constantly strive to offer products that do the job. But we expect more of ourselves than that. We also work hard to ensure that our products are as easy to use as they are effective. For that reason, we have developed this Dyna-Glide catalog. We've created a format we believe will make it easier for you to find what you're looking for and to order the products you need to get the job done.

Depending on the product, you may find sections on what it is, what it features, how it's used, why it's used, product specifications, and ordering information. The ordering information is displayed in easy-to-use charts that allow you to more readily compare similar products as well as products used together. And the charts include a column outlining special considerations that can make ordering, installing, and using them easier and more reliable.

We hope you find this approach helpful. If you have questions that aren't answered by the information in the catalog, don't hesitate to call one of our Customer Service Specialists. They're ready to help you configure your system. Just call 1-888-421-8324.



Dyna-Glide® Climbing Protection Systems – Table of Contents

	<i>Part No.</i>	<i>Page</i>
What is the Dyna-Glide Climbing Protection System?	—	2
Why use the Dyna-Glide Climbing Protection System?	—	2
Why is the Dyna-Glide Climbing Protection System a great product?	—	2
Dyna-Glide Rail Sections		
<i>Vertical Use</i>		
Notched Straight Rail Section	506270	4
Notched Bent Rail Section	506272, 506293, 506323	4
Notched Curved Rail Section	506548, 506549	4
<i>Horizontal Use</i>		
Unnotched Straight Rail Section	506280	5
Unnotched Bent Rail Section	Custom	5
Unnotched Curved Rail Section	506543, 506545	5
Dyna-Glide Rail Mounting Assemblies		
Rung Mounting Assembly	506273	7
Rung Standoff Mounting Assembly	506325	7
Rung Standoff Base Mounting Assembly	506326	7
Double Alligator Clamp Mounting Assembly, 1" Spacer	506386	8
Double Alligator Clamp Mounting Assembly, 1/2" Spacer	506385	8
Wood Pole, Lag Screw, Mounting Assembly	506365	8
Angle Corner Mounting Assembly	506283	9
Angle Corner Base Mounting Assembly	506282	9
Angle Edge Mounting Assembly	506320	9
Flat Mounting Assembly	506318	10
Column Mounting Assembly	506307	10
Dyna-Glide Ladder/Rail Combination (LRC) Sections		
Ladder/Rail Combination (LRC) Section	506390	11
Bent LRC Section	506491	11
Dyna-Glide Ladder/Rail Combination Mounting Assemblies		
Standoff Plate and Adjuster Plate Mounting Assembly	506387	12
Twin Arm Plate and Adjuster Plate Mounting Assembly	506392	12
Standoff Corner Mounting Assembly	506398	12
Standoff Corner Base Mounting Assembly	506400	13
Standoff Corner Mounting Assembly, Large Angle	506500	13
Standoff Corner Base Mounting Assembly, Large Angle	506501	13
Standoff Mounting Assembly	506388	14
Standoff Base Mounting Assembly	506389	14
24" Face Mount Mounting Assembly	506397	14
24" Face Mount Base Mounting Assembly	506401	15
50" Face Mount Mounting Assembly	506399	15
Steel Pole Standoff Mounting Assembly	506410	15
Standoff Flat Mount Bracket Assembly	10011502	16
Standoff Flat Mount Base Bracket Assembly	10011503	16
Wood Pole Standoff Mounting Assembly	506411	16
Dyna-Glide Companion Components and Accessories		
Rail Connector Assembly	506329	18
LRC Side Rail Connector Assembly	506391	18
Gated Bottom End Stop Assembly	506275	18
Gated Top End Stop Assembly	506274	19
Ungated End Stop Assembly	506312	19
Gated Horizontal End Stop Assembly	506337	19
Dyna-Glide Fall Arrester	506277	20
Carabiner	506259	20
Ice Scraper	506405	20
Folding Footrest Assembly	506384	21
Wood Pole Folding Footrest Assembly	506402	21
Large Diameter Wood Pole Folding Footrest Assembly	506408	21
Swingaway Folding Footrest Assembly	506403	22
Pivot Davit Assembly	506357	22
Pivot Davit Assembly with Anchorage Ring	506414	22
Roundabout System	506380	23
Turntable Assembly	506310	23
Pullover™ Harness	502733	24
Dyna-Glide Rescue System	501442	24
Examples of Dyna-Glide Assembly & Applications	—	26
Ordering Considerations	—	32

What is the Dyna-Glide Climbing Protection System?

The MSA Dyna-Glide product is a rigid rail climbing system that can play an important role in your overall worker safety program.

The Dyna-Glide Climbing Protection Systems are used to prevent and/or arrest falls from heights while enhancing the way a climber is able to perform the necessary work. Our systems can be mounted to already-installed ladders, to corners of lattice towers, and to other suitably strong structures your crew needs to climb.

However, using different MSA mounting assemblies, Dyna-Glide systems can be attached to almost any structure that it's permissible to climb. Systems can be constructed to continuously protect climbers – whether they're traveling vertically, horizontally, or around curves, corners, or obstacles.

For added performance, the Dyna-Glide system can be used by more than one person at a time.

As you plan for your project, it may be helpful to remember that a complete Dyna-Glide system consists of:

- Standard joinable straight rail sections (7' 4 3/16" or 2240mm)
- Custom (built to specification) curved rail sections whether concave, convex, or compound (if needed)
- Standard rail connector assemblies used to couple rail sections together
- Standard mounting assemblies for attachment of rail sections to fixed ladders and other structures
- Custom (built to specification) mounting assemblies for attachment of rail sections to structural members of many different non-standard configurations (if needed)
- Fall arrester to engage in the rail sections, permit the climber to move to work position, permit travel along the rail, and stop against a rail notch in case the climber falls
- End stops to prevent the fall arrester from slipping out of the bottom or top end of a run of rail sections
- Full body harness
- Variety of accessories to enhance mobility and provide continuous protection, convenience, and comfort (if needed)
- For illustrations of some typical Dyna-Glide systems, refer to pages 26–31 of this catalog.

Why use the Dyna-Glide Climbing Protection System?

Your employees are your most important asset. So, it just makes sense to choose the Dyna-Glide system as one component in your safety program.

Whatever configuration works for you, the Dyna-Glide system:

- Limits total fall distance to inches—shock loads are below the threshold of injury and well below maximum limits set by OSHA
- Offers components for complete rescue systems
- Allows for vertical and horizontal mobility
- Uses galvanized or stainless steel for corrosion resistance
- Offers your choice of Ladder Rail Combination (LRC) or Rail only
- Provides smooth travel—there's no binding of the fall arrester inside the rail
- Offers rails in straight or curved sections—enough choices to fit almost any size or shape of structure
- Offers many different configurations—plus all of the accessories and mounting brackets to fit virtually any application
- Eliminates concern of system slippage found in frictional design systems—due to our Mechanical Design
- Offers product life of 20+ years—that's at least 3 times the life (3-7 years) of standard cable systems
- Optional fixed ladder section meeting OSHA and ANSI A 14.3 standards with an integral rail mounted in the center of the ladder (Ladder Rail Combination)
- Offers sufficient foot-clearance on either side of the rail for easy climbing (Ladder Rail Combination)
- Uses rugged steel members to direct potential fall arrest loads into the ground rather than into the structure—reduces stress to, and prevents damage to, structure during climbing operations
- Orients fallen worker in the upright position, face toward climbing structure
- Operates using detachable, lightweight, stainless steel and aluminum mechanism for handsfree ascent and descent—a simple, durable, easy-to-use Fall Arrest System
- Shows a decade-plus track record of performing in some of the most severe weather conditions in the world

Why is the Dyna-Glide Climbing Protection System a great product?

There are lots of reasons why the Dyna-Glide system is the product of choice for so many companies.

- It's versatile – so you can use it in a number of ways. Choose from rail or ladder rail combination—either offers hands free operation.
- It's durable—the Dyna-Glide system will give you the service you need for a long time. We use all steel construction and a hot dipped galvanized finish to stand up to the elements for years to come. And that same durability means minimal maintenance.
- It's adaptable—Some systems are designed to work only in standard situations. the Dyna-Glide system can be configured to fit most structures. Plus, we offer the mounting brackets and accessories to make custom installations easy.
- It's tough—Your Dyna-Glide system is manufactured to stand up to even the harshest environmental conditions.
- It's supported—MSA provides a complete package of products, engineered services (for installation), and training.

Dyna-Glide Rigid Rail Climbing System vs. Flexible Cable Climbing Systems

Feature	Rigid Rail System	Flexible Cable System	Comments
Offers product life of 20+ years	YES	NO	Flexible cable system life is typically 3-7 years
Allows for vertical to horizontal, or horizontal to vertical transitions, without disconnecting from system	YES	NO	The Dyna-Glide Rigid Rail System provides 100% continuous tie-off during transition
Limits total fall distance by using a mechanical fall arrester design	YES	NO	Flexible cable systems use a frictional fall arrester design which permits slippage on line, and increases total fall distance
Allows for hands-free ascending and descending	YES	SOMETIMES	Some flexible cable systems require manual unlocking of fall arrester for descent
Allows for different configurations for attachment to almost any type of structure	YES	NO	The Dyna-Glide Rigid Rail System has over 25 different types of mounting brackets
Allows for different configurations for almost any application	YES	NO	The Dyna-Glide Rigid Rail System has over 40 different accessories
Available in straight or curved sections	YES	SOMETIMES	Most flexible cable systems can only be used in straight lines
Allows for vertical and horizontal mobility	YES	NO	Flexible cable systems are primarily designed to be used in vertical applications
Allows one worker to climb past another while both workers maintain connection	YES	NO	The Dyna-Glide allows for one user to bypass another when using the same system
Braking mechanism effective regardless of temperature, moisture, or icing	YES	NO	Frictional braking mechanism on flexible cable systems is susceptible to greater fall distances if cable is wet or icy
Distributes fall arrest forces throughout the structure in the event of a fall	YES	NO	Fall arrest forces on a flexible cable system are distributed only to the top of the structure

Dyna-Glide offers so much more. Here are just a few of the advantages you enjoy when you choose the Dyna-Glide system.

Locking Mechanism

Our systems rely exclusively on mechanical braking action of the locking pawl against steel tabs formed on the safety rail at 5.5 inch intervals. For you, that means the MSA system will stop a fall within the shortest fall arrest distance. Best of all, our braking mechanism is not affected by temperature, moisture, or icing—all the things that can reduce the effectiveness of a frictional braking system.

Fall Arrester Design

Our fall arrester is constructed with a lightweight aluminum body enhanced with a stronger, more durable, stainless steel locking pawl. It also features stainless steel wheels riding on engineered bearings for increased equipment life span. Our Fall Arrester is compact and lightweight – so it travels up and down the safety line smoothly and easily.

End-Stop Design

MSA's gated top and bottom end-stops are specially designed to work with our Fall Arrester system to prevent the arrester from accidentally being installed upside-down. This engineered-in control prevents the possibility of operator error or misuse.

Rail Design

The Dyna-Glide system is fabricated with slots that can be used to mount the rail or ladder section at any point – regardless of how the section is cut to length – without drilling or modifying the product. This speeds installation and reduces the chance of field errors that could weaken the safety rail.

Mounting Brackets and Assemblies

Working with customers who have provided us with field experience data, MSA has developed a wide range of standard mounting hardware for rail or ladder-rail-combination systems. These mounting assemblies assure you that a MSA ladder-climbing safety system is available for virtually every type of structure you may encounter. In most situations, our mounting assemblies have a bracket that is shaped and sized to mate with certain common structural members. Custom assemblies can be built to specification.

Aluminum versus Steel Construction

MSA Dyna-Glide systems use all-steel construction with a heavy, hot-dipped galvanized finish. Steel rail and ladder-rail-combinations are fabricated using high-tensile carbon steel. All welding is performed by certified welders. The galvanized finish is a “self-healing” zinc coating that will migrate to cover nicks and scratches in the steel and provide corrosion protection for the life of the product. In fact, the design life of the steel Dyna-Glide system is at least 20 years in outdoor environments.

Accessories

Our systems can be equipped the way you want them. Simply choose from our wide range of useful accessories to match the way you work. These accessories include: folding foot rests – offering convenient rest positions, they fold out of the way for unimpeded climbing; roundabout work platform – provides 360 degree mobility so workers at the top of the tower can work hands-free on antenna structures; and tower rescue system – a complete rescue system for lowering an incapacitated worker from the Dyna-Glide system to a safe working level.

Installation and Support

MSA offers the flexibility that can make all the difference in your job. We offer Field Rigging Crews, so you'll have the manpower needed to get the job done. Or, if you prefer, we have As-Built Documentation for every aspect of the product. We also offer full training by a “competent” person – either at our training facility or on your job site. Choose the option that works best for you and your employees.

Dyna-Glide Rail Sections

NOTCHED STRAIGHT RAIL SECTION

What it is:

Straight U-shaped channel for vertical travel of the Dyna-Glidefall arrester and ice scraper. For mounting on existing ladders or structure.

What it features:

- Notches for stopping the fall arrester's travel within 5 1/2" (140mm) if the attached climber falls.
- Slots for interconnection of rails and attachment to ladder or structural members (using a variety of mounting assemblies).
- Standard length of 7' 4-3/16", standard rail width of 2"

How it's used:

- Rail sections may be joined end-to-end with a rail connector assembly (see page 18).
- Straight notched rail sections interface compatibly with:
 - curved rail sections
 - horizontal rail
 - Ladder/Rail Combination (LRC) sections
- Interfaces compatibly with a variety of accessories

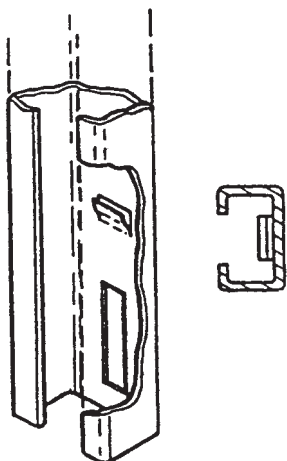

Model No.	Steel Type
506270	Galvanized
506288	Stainless Steel

NOTCHED BENT RAIL SECTION

What it is:

U-shaped channel for vertical travel of the Dyna-Glide fall arrester and ice scraper with one or more bends (made to specification at the factory). Used to avoid obstructions in the path of a rail system. For mounting to existing ladders or structure.

What it features:

Bends are available as follows:

- Simple
- One bend per rail section
- Concave – toward climber
- Convex – away from climber
- Compound – more than one bend radius per rail section
- Can include both convex and concave
- Concave — maximum bend is 15 °
- Bend radius - 24" (610mm) - occurs in center of rail section unless otherwise specified
- Standard length of 7' 4-3/16", standard rail width of 2"

How it's used:

- Rail sections may be joined end-to-end with a rail connector assembly (see p. 18).
- Curved rail sections interface compatibly with:
 - straight rail sections
 - horizontal rail
 - Ladder/Rail Combination (LRC) sections
- Also interfaces compatibly with a variety of accessories

Model No.	Steel Type
Concave	
506272	Galvanized
Convex	
506293	Galvanized
Compound	
506323	Galvanized

NOTCHED CURVED RAIL SECTION

What it is:

U-shaped channel for vertical travel of the Dyna-Glide fall arrester and ice scraper with continuous curvature throughout length of rail section. For mounting on existing ladders or structure.

What it features:

- Curve made to specification at the factory.
- Minimum curve radius is 4' (1.2m)
- Standard length of 7' 4-3/16", standard rail width of 2"

How it's used:

- To conform rail systems to curved structures (such as water towers)
- Curve may be:
 - Concave (toward climber)
 - Convex (away from climber)

Model No.	Steel Type
Concave	
506548	Stainless Steel
Convex	
506549	Galvanized

Dyna-Glide Rail Sections

UNNOTCHED STRAIGHT RAIL SECTION

(For use in horizontal applications only)

What it is:

Straight U-shaped channel for vertical travel of the Dyna-Glide fall arrester and ice scraper without notches to stop the fall arrester. For mounting on existing structure. Use in horizontal travel only (this rail is used in travel restriction applications, not fall arrest applications)!

What it features:

- Unnotched rail allows rail arrester to move horizontally in either direction without catching on notches
- Provides secure lateral mobility for climber.
- Standard length of 7' 4-3/16", standard rail width of 2"

How it's used:

- Rail sections may be joined end-to-end with a rail connector assembly (see p. 18)
- Straight unnotched rail sections interface compatibly with:
 - Curved rail sections
 - Vertical rail
 - Ladder/Rail Combination (LRC) sections.
- Also interfaces compatibly with a variety of accessories

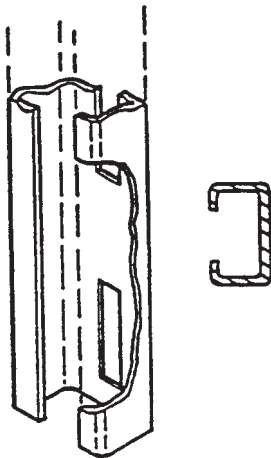

Model No.	Steel Type
506280	Galvanized
506281	Stainless Steel

See Safety Note in Ordering Information.

UNNOTCHED BENT RAIL SECTION

(For use in horizontal applications only)

What it is:

U-shaped channel for vertical travel of the Dyna-Glide fall arrester and ice scraper with one or more bends (made to specification at the factory) *without* notches. Used to avoid obstructions in the path of a rail system. For mounting on existing structure. Use in horizontal travel only, not fall arrest applications!

What it features:

Bends are available as follows:

- Simple
- One bend radius per rail section
- Concave – toward climber
- Convex – away from climber
- Compound – more than one bend radius per rail section
- Can include both convex and concave
- Bend radius - 24" (610 mm) - occurs in center of rail section unless otherwise specified
- Standard length of 7' 4-3/16", standard rail width of 2"

How it's used:

- Rail sections may be joined end-to-end with a rail connector assembly (see p. 18)
- Curved rail sections interface compatibly with:
 - Straight rail sections
 - Vertical rail
 - Ladder/Rail Combination (LRC) sections.
- Also interfaces compatibly with a variety of accessories

Custom

Concave, convex, and compound bends are available upon request. Contact MSA Customer Service Center for ordering information.

UNNOTCHED CURVED RAIL SECTION

(For use in horizontal applications only)

What it is:

U-shaped channel for vertical travel of the Dyna-Glide fall arrester and ice scraper with continuous curvature throughout length of rail section but without notches. For mounting on existing structure. Use in horizontal travel only (this rail is used in travel restriction applications, not fall arrest applications)!

What it features:

- Curve made to specification at factory
- Minimum curve radius is 4' (1.2m)
- Standard length of 7' 4-3/16", standard rail width of 2"

How it's used:

- Used to conform rail systems to curved structures (such as water towers)
- Curve may be:
 - Concave (toward climber)
 - Convex (away from climber)

Model No.	Steel Type
Concave	
506543	Galvanized
Convex	
506545	Galvanized

Dyna-Glide Rail Sections

Ordering Information

Rail Type	Model No.	Steel Type	Special Considerations	Weight	
Notched Straight				Lbs	Kg
	506270	Galvanized		13.6	6.2
	506288	Stainless Steel		13.6	6.2
Notched Bent				Lbs	Kg
Concave	506272	Galvanized	Bend angle must be specified when ordering	13.6	6.2
Convex	506293	Galvanized	Bend angle must be specified when ordering	13.6	6.2
Compound	506323	Galvanized	Bend angle must be specified when ordering	13.6	6.2
Notched Curved				Lbs	Kg
Concave	506548	Stainless Steel	Curve radius must be specified when ordering	13.6	6.2
Convex	506549	Galvanized	Curve radius must be specified when ordering	13.6	6.2
NOTE: Unnotched rail is for horizontal travel only and must never be installed vertically.					
Unnotched Straight				Lbs	Kg
	506280	Galvanized		13.6	6.2
	506281	Stainless Steel		13.6	6.2
Unnotched Curved Rail Section				Lbs	Kg
Concave	506543	Galvanized	Curve radius must be specified when ordering	13.6	6.2
	506544	Stainless Steel	Curve radius must be specified when ordering	13.6	6.2
Convex	506545	Galvanized	Curve radius must be specified when ordering	13.6	6.2
	506546	Stainless Steel	Curve radius must be specified when ordering	13.6	6.2

Items above are available in stainless steel upon request.
 Contact MSA Customer Service Center for ordering information.

Dyna-Glide Rail Mounting Assemblies

RUNG MOUNTING ASSEMBLY

What it is:

For mounting rail sections to the rungs of a fixed ladder or compatible structural member.

How it's used:

- For use on circular cross section rungs with 1/2" to 1" (13 to 25mm) diameter
- Also works on angle iron used for horizontal structural members or rungs
- Two rung mounting assemblies are required for each rail section



Model No.	Steel Type
506273	Galvanized
506286	Stainless Steel

RUNG STANDOFF MOUNTING ASSEMBLY

What it is:

For mounting rail sections on narrow ladders or structures with horizontal support members.

What it features:

- Provides 2-1/4" (57mm) of standoff from the structure to provide adequate foot room

How it's used:

- May be used on structures with horizontal supports ranging from 14" to 18" (356 to 457mm) in width
- May be used on rungs with diameter ranging from 5/8" to 1-1/4" (16 to 32mm) and on angle iron up to 1" (25mm) wide
- Two assemblies are required for each rail section
- One assembly is required for the top of the lowest section
- The very bottom of the lowest section is anchored using Rung Standoff Base Mounting Assembly P/N 506326

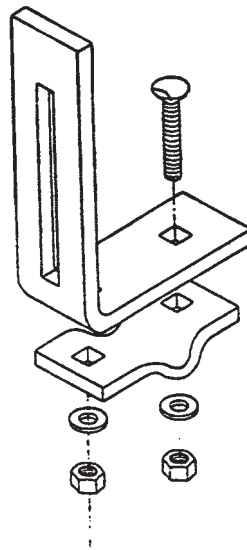

Model No.	Steel Type
506325	Galvanized

RUNG STANDOFF BASE MOUNTING ASSEMBLY

What it is:

For mounting rail on narrow ladders or structures with horizontal support members.

What it features:

- Provides 2-1/4" (57 mm) standoff from the structure to provide adequate foot room

How it's used:

- May be used on structures with horizontal supports ranging from 14" to 18" (356 to 457mm) in width
- May be used on rungs with diameter ranging from 5/8" to 1-1/4" (16 to 32mm) or on angle iron up to 1" (25mm) wide
- One assembly is required for bottom of the lowest rail section
- The top of the lowest rail section and subsequent rail sections are anchored using Rung Standoff Mounting Assembly P/N 506325

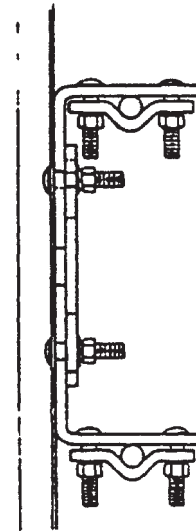

Model No.	Steel Type
506326	Galvanized

Dyna-Glide Rail Mounting Assemblies

DOUBLE ALLIGATOR CLAMP MOUNTING ASSEMBLY, 1" SPACER

What it is:

For mounting rail sections to structures with offset horizontal and diagonal support members.

What it features:

- Establishes a 1" (25mm) standoff from the inner horizontal support member—rail system clears the outer diagonal support

How it's used:

- Assembly mounts to the inner horizontal support
- Two assemblies are required for each rail section

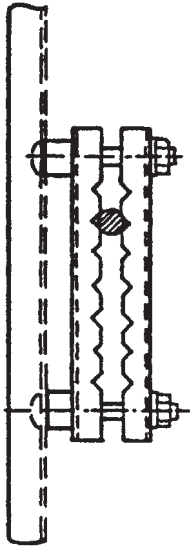

Model No.	Steel Type
506386	Galvanized

DOUBLE ALLIGATOR CLAMP MOUNTING ASSEMBLY, 1/2" SPACER

What it is:

For mounting rail sections to structures with offset horizontal and diagonal support members.

What it features:

- Establishes a 1/2" (13mm) standoff from the inner horizontal support member—rail system clears the outer diagonal support

How it's used:

- Assembly mounts to the inner horizontal support
- Two assemblies are required for each rail section

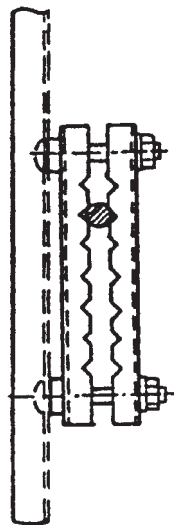

Model No.	Steel Type
506385	Galvanized

WOOD POLE, LAG SCREW, MOUNTING ASSEMBLY

What it is:

For mounting rail sections to wood poles.

How it's used:

- Two assemblies are required for each rail section
- Maximum distance between mounting assemblies is 4' (1219mm)

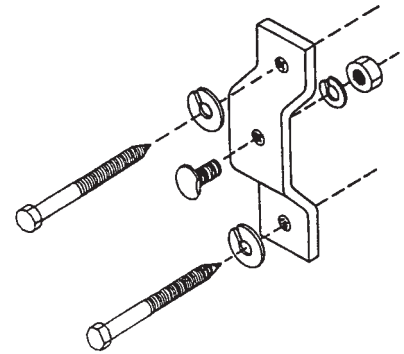

Model No.	Steel Type
506365	Galvanized

Dyna-Glide Rail Mounting Assemblies

ANGLE CORNER MOUNTING ASSEMBLY

What it is:

Component that provides the means for attachment of a rail section to the corner of angle iron structural members—such as at the legs or pylons of towers, where step bolts are used to climb the structure. Consists of a bracket, two clamps for attachment to the edges of the angle and three each bolts, lock washers and nuts.

How it's used:

- Standard size fits structural angle iron from 3-1/2" (89mm) to 8" (203mm) in width and up to 7/8" (22mm) thick
- Two corner mounting assemblies are required for each rail section
- Bottom of the lowest rail section is anchored using Angle Corner Base Mounting Assembly (P/N 506282)

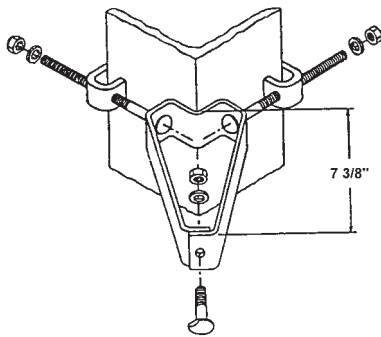

Model No.	Steel Type
506283	Galvanized

ANGLE CORNER BASE MOUNTING ASSEMBLY

What it is:

For mounting the bottom rail section to large angles, such as at the legs or pylons of towers, where step bolts are used to climb the structure.

What it features:

- Standard size fits structural angle iron from 3-1/2" (89mm) to 8" (203mm) in width and up to 7/8" (22mm) thick

How it's used:

- Only one corner mounting base support assembly is required (at the bottom of the lowest rail section) for each rail system
- Top of the lowest rail section and succeeding sections are anchored using Angle Corner Mounting Assembly (P/N 506283)

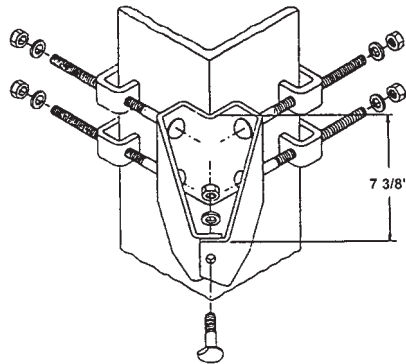

Model No.	Steel Type
506282	Galvanized

ANGLE EDGE MOUNTING ASSEMBLY

What it is:

Component that provides means for attachment of a rail section to the edge of angle iron structural members. Consists of an edge clamp and one each bolt, lock washer, and nut.

What it features:

- Maximum standoff of 2 3/4" from back of rail

How it's used:

- Two assemblies are required for each rail section

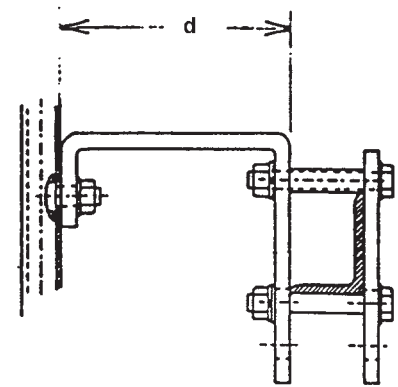

Model No.	Steel Type
506320	Galvanized
506321	Stainless Steel

Dyna-Glide Rail Mounting Assemblies

FLAT MOUNTING ASSEMBLY

What it is:

Component that provides means for attachment of a rail section to flat-surfaced structural members. Consists of a bracket and two each bolts, lock washers, flat washers and nuts.

How it's used:

- Each mount requires a flat surface of 1.97" x 0.39" (50mm x 10mm)
- Two assemblies are required for each rail section

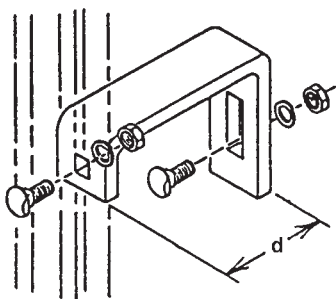

Model No.	Steel Type
506318	Galvanized
506319	Stainless Steel

COLUMN MOUNTING ASSEMBLY

What it is:

Component that provides means for attachment of a rail section to poles and pipes. It consists of an adjustable bracket and five each bolts, lock washers, and nuts, plus eight each flat washers. Various bracket adaptations are available, built to specification, for different column sizes and cross-sectional shapes.

What it features:

- Minimum column/pipe diameter is 4" (102mm)

How it's used:

- Two assemblies are required for each rail section

NOTE: Column/pipe diameter must be constant throughout entire rail system or different mounting assemblies must be used.

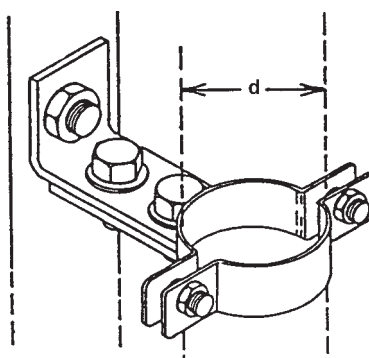

Model No.	Steel Type
506307	Galvanized

Ordering Information

Assembly Item	Model No.	Steel Type	Special Considerations	Weight	
				Lbs	Kg
Rung	506273	Galvanized	2 per section required	1.9	0.9
Rung	506286	Stainless Steel	2 per section required	1.9	0.9
Rung Standoff	506325	Galvanized		4.3	2.0
Rung Standoff Base	506326	Galvanized		8.0	4.3
Double Alligator Clamp, 1"; spacer	506386	Galvanized		2.0	0.9
Double Alligator Clamp, 1/2" spacer	506385	Galvanized		2.0	0.9
Wood Pole Lag Screw	506365	Galvanized		2.9	1.3
Angle corner	506283	Galvanized	Specify angle size when ordering	5.3	2.4
Angle corner base	506282	Galvanized	Specify angle size when ordering	12.8	5.8
Angle edge	506230	Galvanized	Specify angle iron size and length when ordering	2.0	0.9
Flat	506318	Galvanized	Specify length when ordering	3.0	1.4
NOTE: Column/pipe diameter must be constant throughout entire rail system or different mounting assemblies must be used.					
Column	506307	Galvanized	Specify column/pipe diameter when ordering	4.0	1.8

Items above are available in stainless steel upon request.
Contact MSA Customer Service Center for ordering information.

Dyna-Glide Ladder/Rail Combination (LRC) Sections

LADDER/RAIL COMBINATION (LRC) SECTION

What it is:

Steel Ladder Section with an integral notched rail for fall protection.

What it features:

- A centrally mounted rail welded to the center of the ladder rungs
- Ladder rungs are 18 -1/4" (464mm) in width, leaving 8" (203mm) of foot room either side of the rail
- Rungs have a skid resistant surface
- Ladder side rails have square cut-outs for attachment of side rail connector assemblies and LRC mounting assemblies
- Standard length of 7' 4-3/16", standard width of 18"

How it's used:

- LRC sections may be joined end-to-end with a rail connector assembly
- Straight LRC sections interface compatibly with bent LRC sections, rail sections and a variety of accessories
- Provides access to areas where no ladder currently exists and to provide fall protection during climbing

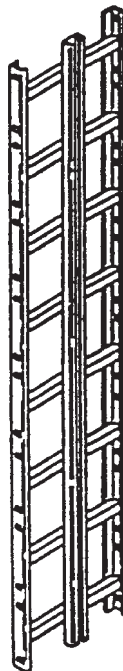

Model No.	Steel Type
506390	Galvanized
506513	Stainless Steel

BENT LRC SECTION

What it is:

Steel Ladder Section with an integral notched rail for fall protection—with bends made to specification at the factory.

What it features:

Bends are available as follows:

- Bend radius is 24" (610mm), and will occur in center of rail section unless otherwise specified
- Simple
- One bend radius per rail section
- Concave – toward climber
- Convex – away from climber
- Compound
- More than one bend radius per rail section
- Both concave and convex bend
- Maximum bend is 15 degrees.
- Standard length of 7' 4-3/16", standard width of 18"

How it's used:

- With Ladder/Rail Combination sections.
- Provides access to areas where no ladder currently exists and to provide fall protection during climbing

Model No.	Steel Type
Concave	
506491	Galvanized

Custom concave and compound bends are also available upon request. Contact MSA Customer Service Center for ordering information.

Ordering Information

Item	Model No.	Steel Type	Special Considerations	Weight	
				Lbs	Kg
LRC Section	506390	Galvanized		43.8	19.8
LRC Section	506513	Stainless Steel		43.8	19.8
Bent LRC Section			Specify bend angle when ordering		
Concave	506491	Galvanized	Specify bend angle when ordering	43.8	19.8

Items above are available in stainless steel upon request. Contact MSA Customer Service Center for ordering information.

Dyna-Glide Ladder/Rail Combination Mounting Assemblies

STANDOFF PLATE AND ADJUSTER PLATE MOUNTING ASSEMBLY

What it is:

Component that attaches LRC sections to a structure with horizontal support members.

What it features:

- Establishes a minimum standoff of 7" (278mm) between the ladder rungs and the structure to provide adequate foot room

How it's used:

- May be used on round support members up to 2 -1/2" (64mm) in diameter or angle supports up to 2.5" x 2.5" (64 x 64mm) in width
- Two mounting assemblies (one each side of the ladder) are required at intervals of no more than 7'4" (2235mm) along the entire length of the LRC run

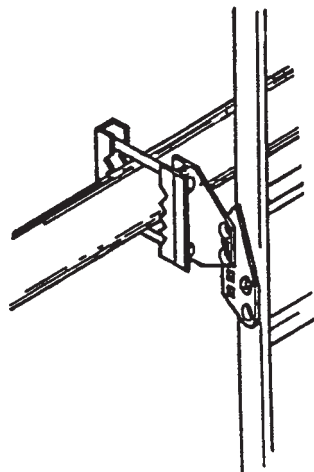

Model No.	Steel Type
506387	Galvanized
506518	Stainless Steel

TWIN ARM PLATE AND ADJUSTER PLATE MOUNTING ASSEMBLY

What it is:

Component that fastens LRC sections to structures with horizontal or diagonal support members.

What it features:

- May be used on round support members up to 2.5" (64mm) in diameter or angular supports up to 4" x 4" (102 x 102mm) in width
- Establishes a minimum standoff of 7"-13" (278 - 330.2mm) between the ladder rungs and the structure to provide adequate foot room

How it's used:

- Two mounting assemblies (one each side of the ladder) are required at intervals of no more than 7' 4" (2235mm) along the entire length of the LRC run

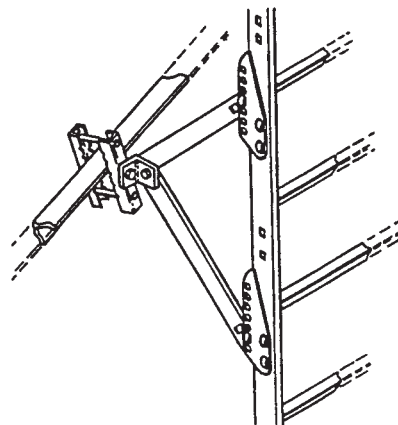

Model No.	Steel Type
506392	Galvanized

STANDOFF CORNER MOUNTING ASSEMBLY

What it is:

Component that attaches LRC sections to the vertical corner member of a structure.

What it features:

- Establishes a minimum standoff of 7" (278mm) between the ladder rungs and the structure to provide adequate foot room.

How it's used:

- May be used on round supports up to 3.5" (89mm) in diameter or angled supports up to 4" x 4" (102 x 102mm) in width
- One mounting assembly is required for each LRC section to be mounted
- The bottom LRC section is attached using Standoff Corner Base Mounting (P/N 506400)

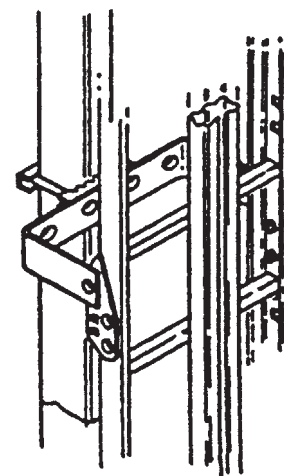

Model No.	Steel Type
506398	Galvanized

Dyna-Glide Ladder/Rail Combination Mounting Assemblies

STANDOFF CORNER BASE MOUNTING ASSEMBLY

What it is:

Component that anchors the bottom section of LRC to the vertical corner member of a structure.

What it features:

- Establishes a minimum standoff of 7" (278mm) between the ladder rungs and the structure to provide adequate foot room.

How it's used:

- May be used on round or angled support members.
- One assembly is required for the very bottom of the lowest section of LRC.
- Succeeding sections are anchored using Standoff Corner Mounting Assembly, P/N 506398.

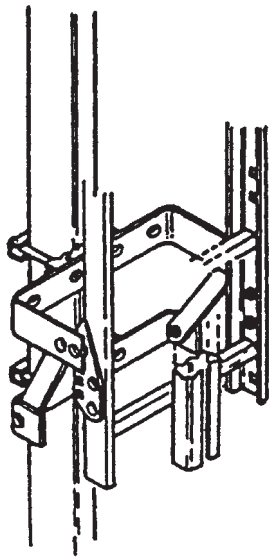

Model No.	Steel Type
506400	Galvanized

STANDOFF CORNER MOUNTING ASSEMBLY, LARGE ANGLE

What it is:

Component that attaches LRC sections to the vertical corner angle member of a structure.

What it features:

- Establishes a minimum standoff of 7" (278mm) between the ladder rungs and the structure to provide adequate foot room

How it's used:

- One mounting assembly is required for each LRC section to be installed
- May be used on angle of 4" to 8" (102 to 203mm) width, and 3/8" to 7/8" (10 to 22mm) thickness
- The bottom LRC section is attached using Standoff Corner Base Mounting Assembly, Large Angle (P/N 506501)

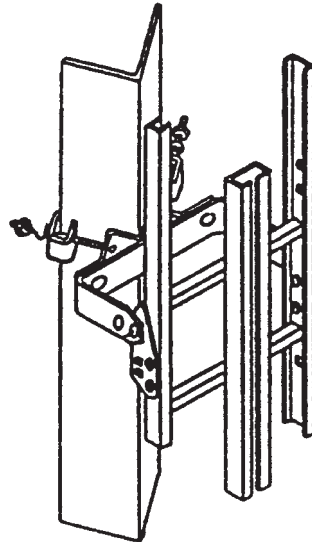

Model No.	Steel Type
506500	Galvanized

STANDOFF CORNER BASE MOUNTING ASSEMBLY, LARGE ANGLE

What it is:

Component that anchors the bottom section of LRC to the vertical corner angle member of a structure.

What it features:

- Establishes a minimum standoff of 7" (278mm) between the ladder rungs and the structure to provide adequate foot room

How it's used:

- One of this assembly is required for the very bottom of the lowest LRC section
- May be used on angle of 4" to 8" (102 to 203mm) width, and 3/8" to 7/8" (10 to 22mm) thickness
- One assembly is required for the bottom section of LRC. Succeeding sections are anchored using Standoff Corner Mounting Assembly, Large Angle (P/N 506500)

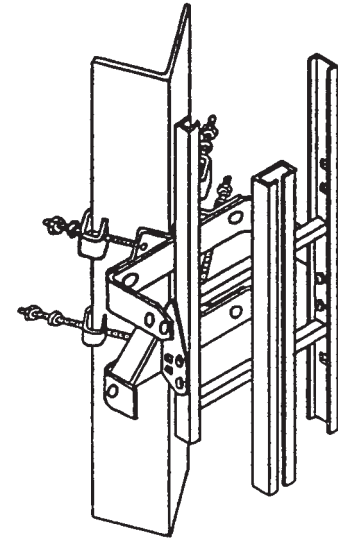

Model No.	Steel Type
506501	Galvanized

Dyna-Glide Ladder/Rail Combination Mounting Assemblies

STANDOFF MOUNTING ASSEMBLY

What it is:

Component that anchors LRC sections to structures which have adjacent vertical support members spaced from 8 -1/2" to 19 -1/2" (216mm to 495mm) apart.

What it features:

- Establishes a minimum standoff of 7" (278mm) between the ladder rungs and the structure to provide adequate foot room

How it's used:

- May be used on round support members up to 3" (76mm) in diameter or angled supports up to 3" x 3" in width
- One mounting assembly is required for each LRC section to be installed
- The very bottom of the lowest LRC section is anchored using Standoff Base Mounting Assembly (P/N 506389)

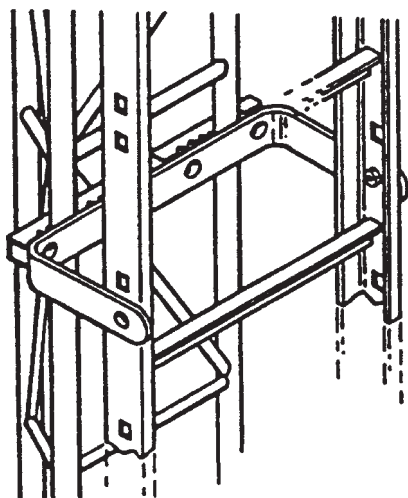

Model No.	Steel Type
506388	Galvanized

STANDOFF BASE MOUNTING ASSEMBLY

What it is:

Component that fastens the lowest LRC section to a structure with adjacent vertical support members spaced from 8 -1/2" to 19 -1/2" (216mm to 495mm) apart.

What it features:

- Establishes a minimum standoff of 7" (278mm) between the ladder rungs and the structure to provide adequate foot room

How it's used:

- May be used on round or angled support members up to 3" (76mm) in diameter
- One mounting assembly is required for the bottom of the lowest LRC section
- Top of the lowest LRC section and all subsequent sections are anchored using the Standoff Mounting Assembly (P/N 506388)

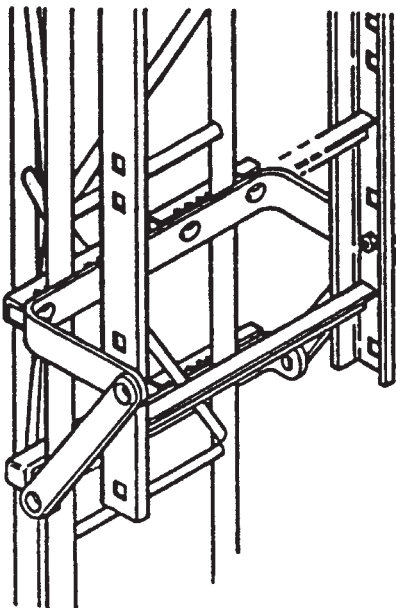

Model No.	Steel Type
506389	Galvanized

24" FACE MOUNT MOUNTING ASSEMBLY

What it is:

Component that anchors LRC sections to a structure with adjacent vertical support members that are spaced from 16" to 27" (406mm to 686mm) apart.

How it's used:

- May be used on round or angled vertical support members up to 3" (76mm) in width
- One mounting assembly is required per LRC section
- The very bottom of the lowest LRC section is fastened using 24" Face Mount Base Mounting Assembly (P/N 506401)

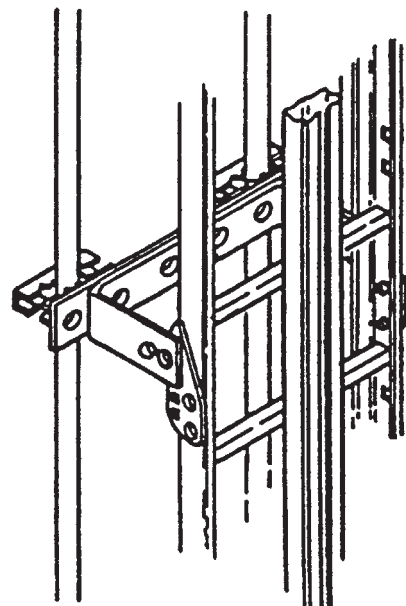

Model No.	Steel Type
506397	Galvanized

Dyna-Glide Ladder/Rail Combination Mounting Assemblies

24" FACE MOUNT BASE MOUNTING ASSEMBLY

What it is:

Component that anchors the bottom LRC section to a structure with adjacent vertical support members that are spaced from 16" to 27" (406mm to 686mm) apart.

How it's used:

- May be used on round or angled vertical support members up to 3" (76mm) in width.
- One mounting assembly is required for the very bottom of the lowest LRC section. Subsequent sections are fastened using 24" Face Mount Mounting Assembly (P/N 506397)

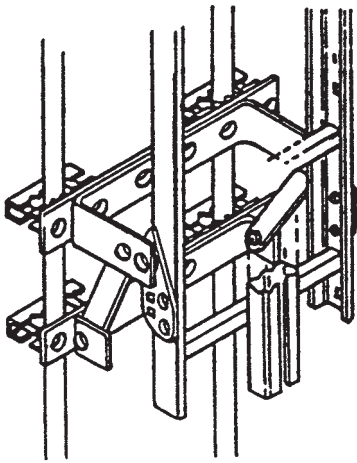

Model No.	Steel Type
506401	Galvanized

50" FACE MOUNT MOUNTING ASSEMBLY

What it is:

Component that anchors LRC sections to a structure with adjacent vertical support members that are spaced from 42-1/2" to 55-1/2" (1080mm to 1410mm) apart.

How it's used:

- May be used on round or angled vertical support members up to 3" (76mm) in width
- One mounting assembly is required per LRC section
- The bottom section requires two mounting assemblies to support the weight of succeeding upper sections

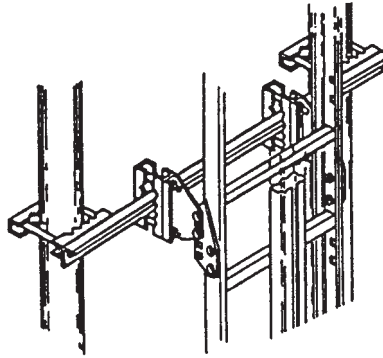

Model No.	Steel Type
506399	Galvanized

STEEL POLE STANDOFF MOUNTING ASSEMBLY

What it is:

Component that mounts LRC sections to a steel pole.

What it features:

- The standoff distance may range from 7" (278mm) to 13" (178mm to 330mm)

How it's used:

- May be used on poles of 5" to 8" (127mm to 203mm) in diameter
- **IMPORTANT: The bottom section of LRC must rest on a surface capable of sustaining a static load of 5,000 lbs**

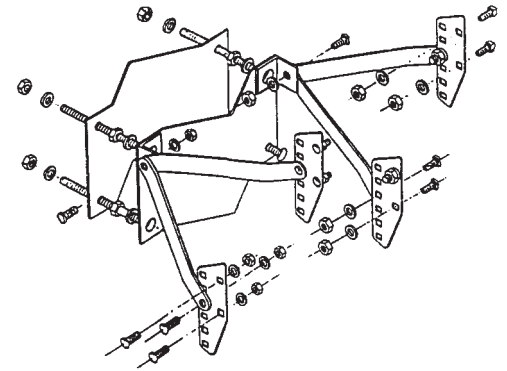

Model No.	Steel Type
506410	Galvanized

Dyna-Glide Ladder/Rail Combination Mounting Assemblies

STANDOFF FLAT MOUNT BRACKET ASSEMBLY

What it is:

Component that anchors LRC sections to a structure with a flat surface, such as a wall. Due to the number of types of structure this bracket can be used on, surface mounting hardware is not included.

What it features:

- Establishes a minimum standoff of 7" between ladder rungs and the structure to provide adequate foot room.

How it's used:

- May be used on structures with a flat surface, such as a wall
- One mounting assembly is required per LRC section
- The very bottom of the lowest LRC section is anchored using the Standoff Flat Mount Base Bracket Assembly (P/N 10011503)

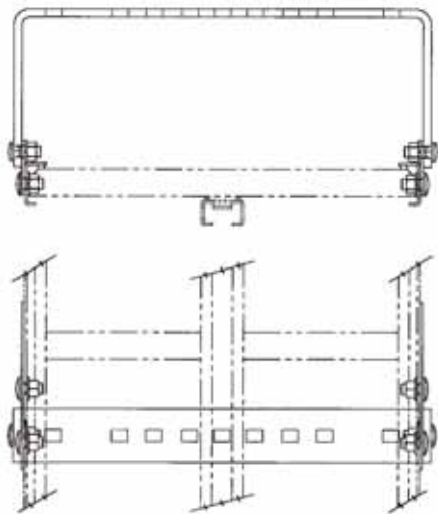

Model No.	Steel Type
10011502	Galvanized

STANDOFF FLAT MOUNT BASE BRACKET ASSEMBLY

What it is:

Component that anchors the bottom LRC sections to a structure with a flat surface, such as a wall. Due to the number of types of structure this bracket can be used on, surface mounting hardware is not included.

What it features:

- Establishes a minimum standoff of 7" between ladder rungs and the structure to provide adequate foot room

How it's used:

- May be used on structures with a flat surface, such as a wall
- One mounting assembly is required for the very bottom of the lowest LRC section
- The top of the lowest LRC section and all subsequent sections are anchored using the Standoff Flat Mount Bracket Assembly (P/N 10011502)

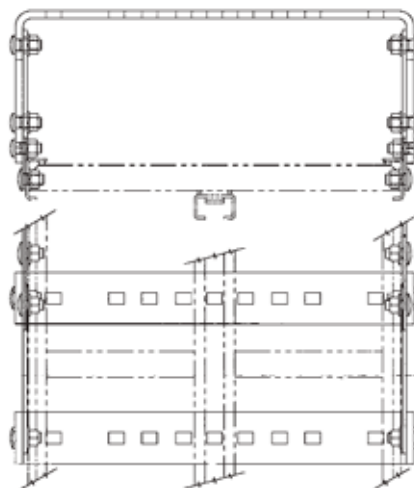

Model No.	Steel Type
10011503	Galvanized

WOOD POLE STANDOFF MOUNTING ASSEMBLY

What it is:

Component that mounts LRC sections to wood poles.

What it features:

- Establishes a minimum of 7" (278mm) standoff between the rungs and the pole

How it's used:

- May be used on any diameter pole
- One mounting assembly is required for each LRC section to be mounted
- Two are required for the bottom LRC section to support the weight of succeeding upper sections

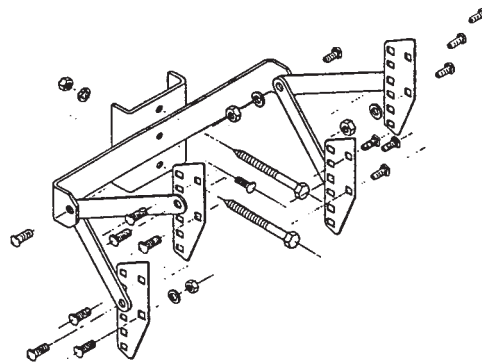

Model No.	Steel Type
506411	Galvanized

Dyna-Glide Ladder/Rail Combination Mounting Assemblies

Ordering Information for Dyna-Glide Ladder/Rail Combination Mounting

Assembly Item	Model No.	Steel Type	Special Considerations	Weight	
				Lbs	Kg
Mounting Assembly, Standoff Plate and Adjuster	506387	Galvanized		6.9	3.1
Mounting Assembly, Twin Arm, Plate and Adjuster Plate	506392	Galvanized		5.6	2.5
Mounting Assembly, Standoff Corner	506398	Galvanized		8.4	3.8
Mounting Assembly, Standoff Corner Base	506400	Galvanized		13.8	6.3
Mounting Assembly, Standoff Corner, Large Angle	506500	Galvanized		10.3	4.7
Mounting Assembly, Standoff Corner Base, Large Angle	506501	Galvanized		17.5	8.0
Mounting Assembly, Standoff	506388	Galvanized		12.0	5.5
Mounting Assembly, Standoff Base	506389	Galvanized		31.5	14.3
Mounting Assembly, 24" Face Mount	506397	Galvanized		14.7	6.7
Mounting Assembly, 24" Face Mount Base	506104	Galvanized		20.1	9.1
Mounting Assembly, 50" Face Mount	506399	Galvanized		18.3	8.3
Mounting Assembly, Wood Pole Standoff	506411	Galvanized		15.6	7.1
Standoff Flat Mount, Bracket Assembly	10011502	Galvanized		7.8	3.5
Standoff Flat Mount, Base Bracket Assembly	10011503	Galvanized		13.2	6.0

Items above are available in stainless steel upon request.
 Contact MSA Customer Service Center for ordering information.

Dyna-Glide Companion Components and Accessories

RAIL CONNECTOR ASSEMBLY

What It Is:

Component that fastens two adjacent rail or LRC center rail sections together.

How It's Used:

Rail Connector Assembly is connected to the back of the rail (or center rail on LRC) to keep adjacent sections of rail in line and correctly abutted to one another. One rail connector assembly is required for each rail section to be connected.

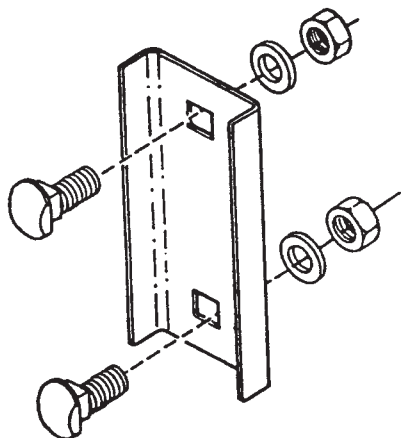

Model No.	Steel Type
506329	Galvanized
506334	Stainless Steel

LRC SIDE RAIL CONNECTOR ASSEMBLY

What It Is:

Component that connects the outside rails of two adjacent LRC sections.

How It's Used:

The Side Rail Connector Assembly is fastened to the LRC section outside rail to keep adjacent sections of LRC in line and correctly abutted to one another. Two side rail connector assemblies are required for each LRC section to be connected.

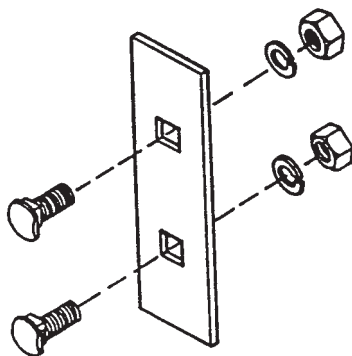

Model No.	Steel Type
506391	Galvanized
506529	Stainless Steel

GATED BOTTOM END STOP ASSEMBLY

What It Is:

A U-shaped component with a gated side that mounts at the bottom of a rail or LRC system to ensure proper insertion of the Fall Arrester.

How It's Used:

This End Stop permits controlled insertion and removal of the Dyna-Glide fall arrester. The ungated side of the End Stop prevents the Fall Arrester from being inserted upside down. The gated side of the End Stop prevents the Fall Arrester from accidentally slipping out of the bottom rail section, and permits the climber to remove the fall arrester from the rail in a controlled way.

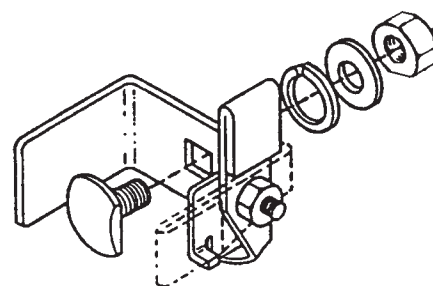

Model No.	Steel Type
506275	Stainless Steel

Dyna-Glide Companion Components and Accessories

GATED TOP END STOP ASSEMBLY

What It Is:

A U-shaped component with a gated side that mounts at the very top of a rail or LRC system to ensure proper insertion of the Fall Arrester.

How It's Used:

This End Stop permits controlled insertion and removal of the Dyna-Glide fall arrester. The ungated side of the End Stop prevents the Fall Arrester from being inserted upside down. The gated side of the End Stop prevents the Fall Arrester from accidentally slipping out of the top rail section, and permits the climber to remove the fall arrester from the rail in a controlled way.

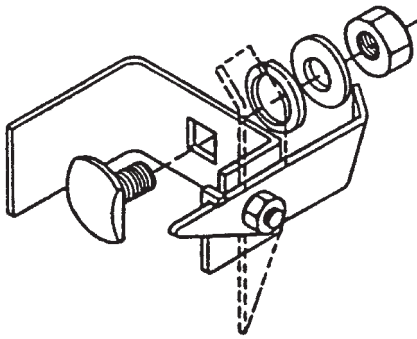

Model No.	Steel Type
506274	Stainless Steel

UNGATED END STOP ASSEMBLY

What It Is:

A U-shaped component with rigid sides that can be mounted at the top or bottom of a rail or LRC system to prevent the Fall Arrester from being removed from the rail.

How It's Used:

This End Stop prevents the Dyna-Glide Fall Arrester from accidentally slipping out of or being removed from the rail. The climber cannot remove the Fall Arrester from the rail where this assembly is installed.

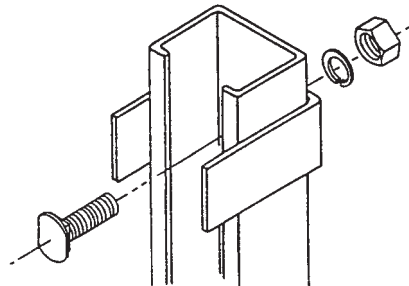

Model No.	Steel Type
506312	Stainless Steel

GATED HORIZONTAL END STOP ASSEMBLY

What It Is:

A U-shaped component with a gated side that mounts at the end of a horizontal rail to ensure proper insertion of the Fall Arrester.

How It's Used:

This End Stop permits controlled insertion and removal of the Dyna-Glide Fall Arrester. The ungated side of the End Stop prevents the Fall Arrester from being inserted in the wrong direction. The gated side of the End Stop prevents the Fall Arrester from accidentally slipping out of the horizontal rail section, and permits the climber to remove the Fall Arrester from the rail in a controlled way.

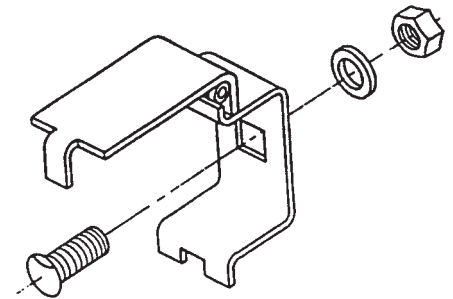

Model No.	Steel Type
506337	Stainless Steel

Dyna-Glide Companion Components and Accessories

DYNA-GLIDE FALL ARRESTER

What It Is:

The Fall Arrester travels in the Dyna-Glide rail and is constructed of an aluminum body with a stainless steel, mechanically locking cam, and a stainless steel ring for connection to an approved body support.

How It's Used:

The Fall Arrester operates in all Dyna-Glide rails. It travels in the rail to provide either fall protection in the vertical rail or travel restriction in the horizontal rail. It permits ascent without resistance and descent by leaning slightly backward. If an accidental fall occurs, the fall is arrested within inches. The Fall Arrester is usually connected to an approved body support using a carabiner.

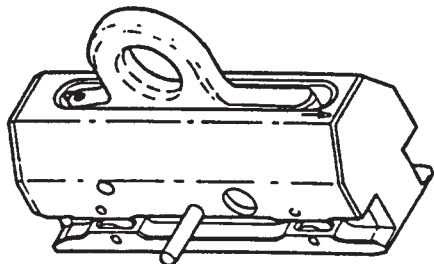

Model No.	Steel Type
506277	Aluminum/ Stainless Steel

CARABINER

What It Is:

A self-closing, self-locking, anchorage connector used in conjunction with the Dyna-Glide Fall Arrester.

How It's Used:

The carabiner is used to connect the Dyna-Glide Fall Arrester (P/N 506277) to a climber's approved body support. It has a minimum tensile strength of 5,000 pounds.

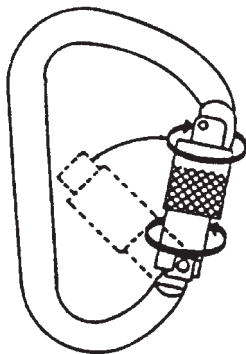

Model No.	Steel Type
506259	Aluminum

ICE SCRAPER

What It Is:

The Ice Scraper is a component that travels in the rail to clear the rail of snow and ice. It is constructed of an aluminum body with a stainless steel grip.

How It's Used:

The Ice Scraper fits inside the rail and is pushed ahead of the Fall Arrester to crack ice off the rail surface and allow the Dyna-Glide to pass smoothly. When it is not being used, the Ice Scraper travels freely in front of the Fall Arrester. When ice or snow is encountered in the rail, the climber manually pushes the Ice Scraper up the rail by way of the stainless steel grip to break away the ice or snow.

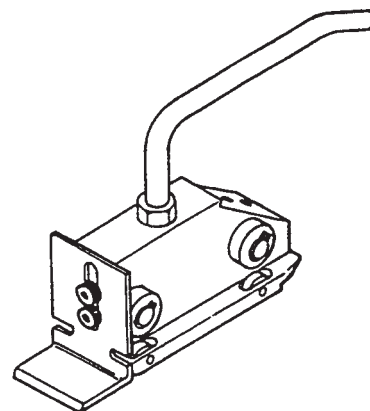

Model No.	Steel Type
506405	Aluminum/ Stainless Steel

Dyna-Glide Companion Components and Accessories

FOLDING FOOTREST ASSEMBLY

What It Is:

The Folding Footrest Assembly is a component that provides a small platform for resting or work positioning on a rail or LRC section.

How It's Used:

The Footrest is attached to the back of the rail or LRC section and is folded upright when not in use, allowing the climber to pass unimpeded. When the climber reaches the footrest on the ladder it can easily be lowered to provide a resting or work positioning platform for the climber. On longer runs of rail or LRC sections, one footrest should be used at least every 30'.

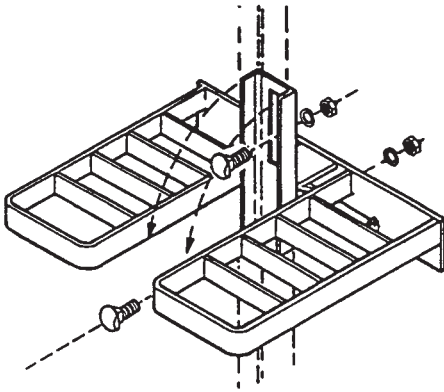

Model No.	Steel Type
506384	Galvanized

WOOD POLE FOLDING FOOTREST ASSEMBLY

What It Is:

The Wood Pole Folding Footrest Assembly is a component that provides a small platform for resting or work positioning on a rail section installed on a wood pole.

How It's Used:

The Footrest is attached to the back of the rail section and is folded upright when not in use, allowing the climber to pass unimpeded. When the climber reaches the footrest on the rail, it can easily be lowered to provide a resting or work positioning platform for the climber. On longer runs of rail sections, one Footrest should be used at least every 30'. The maximum pole diameter that this Footrest can be used on is 12" (305mm).

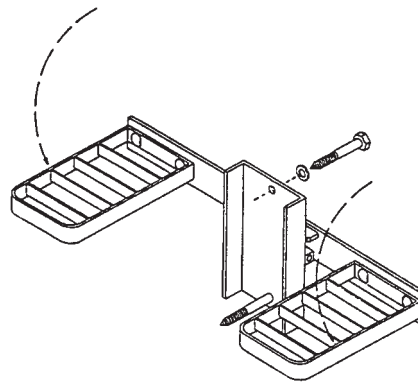

Model No.	Steel Type
506402	Galvanized

LARGE DIAMETER WOOD POLE FOLDING FOOTREST ASSEMBLY

What It Is:

The Wood Pole Folding Footrest Assembly is a component that provides a small platform for resting or work positioning on a rail section installed on a wood pole.

How It's Used:

The Footrest is attached to the back of the rail section and is folded upright when not in use, allowing the climber to pass unimpeded. When the climber reaches the Footrest on the rail, it can easily be lowered to provide a resting or work positioning platform for the climber. On longer runs of rail sections, one Footrest should be used at least every 30'. The pole diameter that this Footrest can be used on is 12" – 16" (305mm – 406mm).

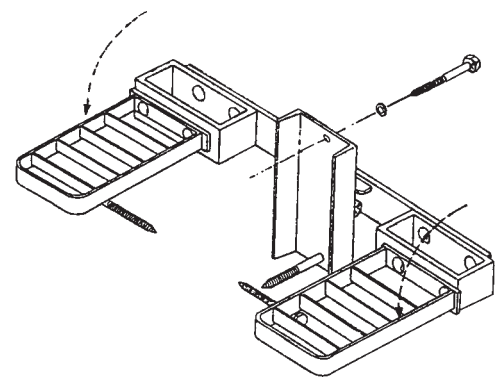

Model No.	Steel Type
506408	Galvanized

Dyna-Glide Companion Components and Accessories

SWINGAWAY FOLDING FOOTREST

What It Is:

The Swingaway Folding Footrest is a component that consists of separate left and right footrests. It is used on rail systems where the configuration of the structure does not permit the use of the standard Folding Footrest, P/N 506384.

How It's Used:

The Swingaway Folding Footrest is attached to the structure on both sides of the center rail. The separate footrests are swung to the side (left footrest swings to left side, right footrest swings to right side) when not in use, allowing the worker to pass unimpeded. When the climber reaches the Footrest on the structure, both sides can be easily swung into position to provide a resting or work positioning platform for the climber. On longer runs of rail sections, one footrest should be used at least every 30'.

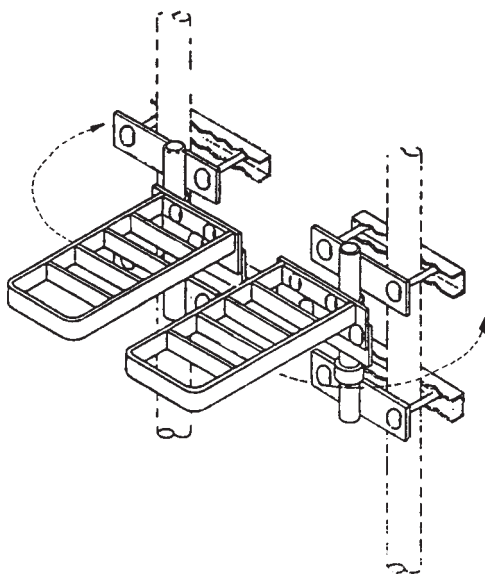

Model No.	Steel Type
506403	Galvanized

PIVOT DAVIT ASSEMBLY

What It Is:

The Pivot Davit Assembly is a component that pivots 360 degrees and is used for dismounting at elevated work platforms without disconnecting from the Dyna-Glide system.

How It's Used:

The Pivot Davit is attached at the very top of a rail or LRC section. It permits the user to pivot onto a ladder landing or work platform without disconnecting from the Dyna-Glide system. Once on the platform or ladder landing, the user can then disconnect from the Dyna-Glide Fall Arrester or remove the Fall Arrester from the davit. This component is particularly useful where successive ladders are offset from each other. The user must provide a separate means of fall protection, after disconnection from the Dyna-Glide system, if environmental work conditions warrant its use.

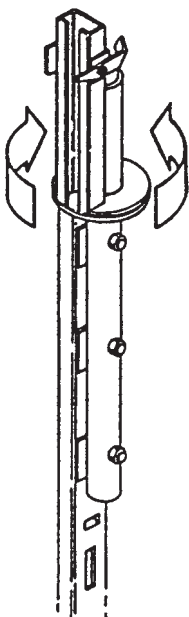

Model No.	Steel Type
506357	Galvanized
506506	Stainless Steel

PIVOT DAVIT ASSEMBLY, ANCHORAGE RING

What It Is:

The Pivot Davit Assembly is a component that pivots 360 degrees and is used for dismounting at elevated work platforms without disconnecting from the Dyna-Glide system. This davit includes an anchorage ring for connection of a personal fall arrest system or a travel restriction system.

How It's Used:

The Pivot Davit is attached at the very top of a rail or LRC section. It permits the user to pivot onto a ladder landing or work platform without disconnecting from the Dyna-Glide system. Once on the platform or ladder landing, the user can then disconnect from the Dyna-Glide Fall Arrester or remove the Fall Arrester from the davit. The integral anchorage ring provides a compatible anchorage point for MSA lanyards to enable continuous tie-off while aloft. This component is particularly useful at locations where disconnection from the Dyna-Glide System is necessary at locations without adequate fall protection means or suitable anchorage points.

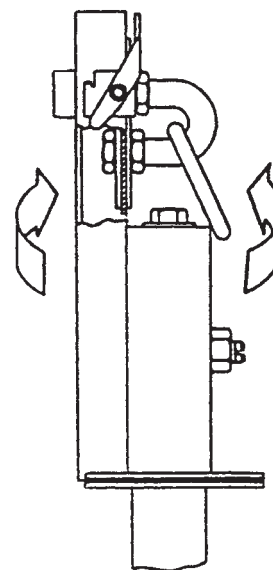

Model No.	Steel Type
506414	Galvanized

Dyna-Glide Companion Components and Accessories

ROUNABOUT SYSTEM

What It Is:

The Roundabout System is a component used for moving horizontally around a pole or mast without disconnection from the Dyna-Glide system. It consists of a roundabout Assembly (curved horizontal carriage guides, and a carriage with an ice guard for the fall arrester); a Pedestal Assembly which serves as a work platform; and an Adaptable Column Mounting Assembly (which prevents escape of the fall arrester from the roundabout and provides hand holds for the user).

How It's Used:

The Roundabout Assembly is installed around the diameter of a pole or mast, and used in conjunction with a bent Rail section. The user would climb up the structure until the Fall Arrester enters the Roundabout Assembly and he/she is standing on the Pedestal Assembly. At that point the user is free to travel horizontally around the pole or mast. The horizontal carriage will rotate around the pole or mast in either direction to allow the user freedom of movement. It is suitable for use on circular structures with a diameter between 6" (152mm) and 12" (305mm). The roundabout system must be purchased as a complete system.

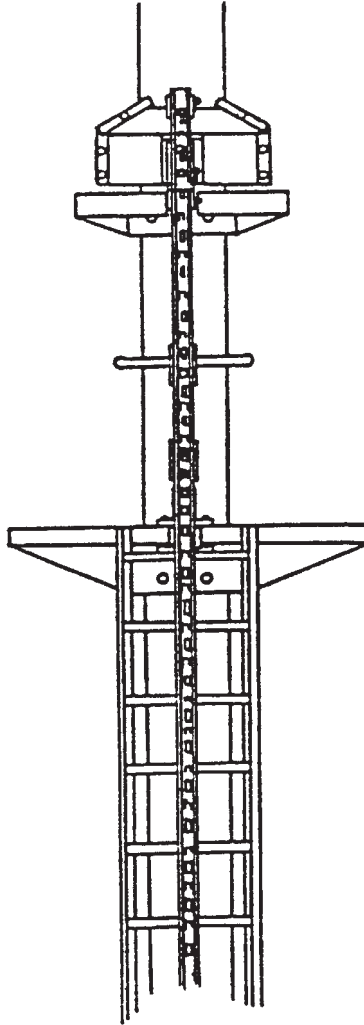

Model No.	Steel Type
Roundabout Assembly	
506380	Galvanized
Adaptable Column Mounting Assembly	
506394	Galvanized
Compound	
506381	Galvanized

TURNTABLE ASSEMBLY

What It Is:

The Turntable Assembly is a component used for direct transfer between vertical and horizontal rail sections without disconnection of the Dyna-Glide fall arrester.

How It's Used:

The Turntable is mounted at any point along the rail or LRC section where the user may need to transition from a vertical rail to a horizontal rail, or a horizontal rail to a vertical rail. The Fall Arrester slides into the turntable, then the Turntable is rotated 90 degrees to effect transfer. The fall Arrester can be moved through the Turntable in any vertical or horizontal direction, but the turntable will not allow the Fall Arrester to enter a vertical rail incorrectly.

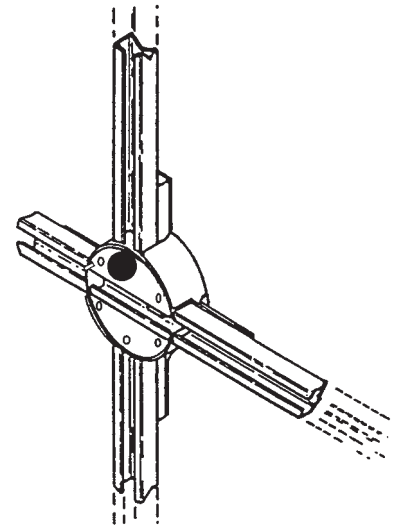

Model No.	Steel Type
506310	Aluminum/ Stainless Steel

Dyna-Glide Companion Components and Accessories

PULLOVER® HARNESS

What It Is:

The Pullover Harness is a lightweight, versatile full-body harness with sub-pelvic support that features color contrasted straps, one overall torso adjustment, and tongue buckle leg straps. This body support is recommended over a body belt.

How It's Used:

The Pullover harness is donned by the user and then attached, by way of a chest D-ring, to the Dyna-Glide Fall Arrester. The Harness is available in a standard size (fits small, medium, and large), as well as extra small and extra large sizes. Different combinations of D-rings (chest, back, hip, shoulder), leg straps (tongue buckle, friction buckle, and qwik-finish t), and accessories (back pads and comfort pads) are available.

NOTE: If you intend to use any body support, or linkage between the fall arrester and body support, other than those supplied by MSA, you should first check with the manufacturer to determine if they are compatible.



Model No.	Material
502733	Nylon
502734	Polyester

THE DYNA-GLIDE RESCUE SYSTEM

What It Is:

The Dyna-Glide Rescue System consists of equipment that, when used in conjunction with each other, allows a Dyna-Glide user to be rescued in the event of a fall. The Dyna-Glide Rescue System consists of the Manual Dynescape™ Descender system (P/N 506416 consists of Dynescape Descender, a 150' rope, anchorage connector strap, carabiner, and tote bag), one carabiner (P/N 506259), a Pullover Harness (P/N 502733), Dyna-Brake twin leg lanyard (P/N 10021659), a modified Fall Arrester (P/N 506538), a Fall Arrester disengagement lanyard (P/N 507177), and a support lanyard (P/N 507178).

How It's Used:

If a climber needs to be rescued from the Dyna-Glide System, the rescuer inserts the modified Fall Arrester into the rail, attaches the remaining equipment to his/her harness, connects to the Fall Arrester, and begins to climb up to the victim. Once the rescuer reaches the victim, the rescuer will connect one leg of the twin leg lanyard to the structure and disconnect from the modified Fall Arrester. Once the rescuer is disconnected from the modified Fall Arrester, the rescuer attaches the snaphook end of the Fall Arrester disengagement lanyard to the back D-ring of the victim, and inserts the pin on the other end of the disengagement lanyard into the modified Fall Arrester. This pin will keep the modified Fall Arrester in the unlocked position and allow it to slide down the rail in a controlled manner. Next the rescuer will climb above the victim using the twin leg lanyard. Once the rescuers' feet are at the head of the victim, the rescuer attaches the Dynescape descender to the structure with the large carabiner. The large carabiner goes through the thimble end of the rope, and the Dynescape is attached to the chest D-ring of the rescuer. Then the rescuer attaches the top of the "T" shaped support lanyard to the hip D-rings of the harness, and the other end is fastened to the victim's Fall Arrester. The rescuer then picks up the victims weight and begins to walk the victim down the ladder. As the rescuer walks down the ladder, the Dynescape controls the descent of both parties. If the rescuer should happen to slip and fall while attempting the rescue, the victim's Fall Arrester would again lock to the rail, and the Dynescape would lock up to arrest the rescuers fall.

Note: Rescue should not be attempted unless additional rescue training has been provided.

Model No.	Description
501442	Dyna-Glide Rescue System

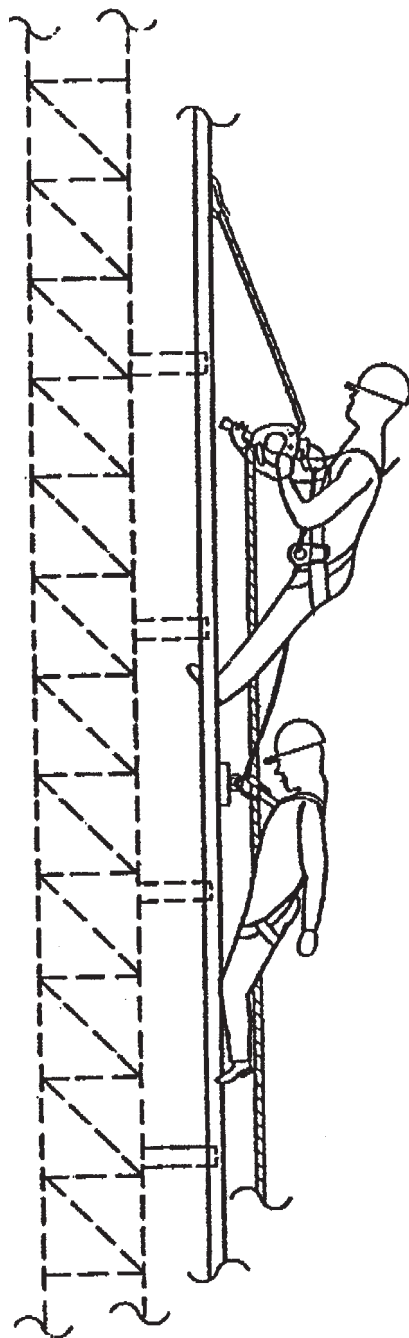

Dyna-Glide Companion Components and Accessories

Ordering Information for Dyna-Glide Ladder/Rail Combination Mounting

Item	Model No.	Type of Material	Special Considerations	Weight	
				Lbs	Kg
Rail Connector Assembly	506329	Galvanized Steel	Ordering Formula: # of Rail or LRC Sections -1	1.0	0.45
Rail Connector Assembly	506334	Stainless Steel	Bolts Included	1.0	0.45
LRC Side Rail Connector Assembly	506391	Galvanized Steel	Ordering Formula: (# of Rail or LRC Sections -1) x 2	0.5	0.2
LRC Side Rail Connector Assembly	506529	Stainless Steel	Bolts Included	0.5	0.2
Gated Bottom End Stop Assembly	506275	Stainless Steel	Bolts Included	0.5	0.2
Gated Top End Stop Assembly	506274	Stainless Steel	Bolts Included	0.5	0.2
Ungated End Stop Assembly	506312	Stainless Steel	Bolts Included	0.2	0.1
Gated Horizontal End Stop Assembly	506337	Stainless Steel	Bolts Included	0.5	0.2
Dyna-Glide Fall Arrester	506277	Aluminum/ Stainless Steel		1.7	0.8
Carabiner	506259	Aluminum		0.2	0.1
Ice Scraper	506405	Aluminum/ Stainless Steel		1.3	0.6
Folding Footrest Assembly	506384	Galvanized Steel		13.5	6.1
Folding Footrest Assembly, Wood Pole	506402	Galvanized Steel		22.0	10.0
Folding Footrest Large Diameter Wood Pole	506408	Galvanized Steel		26.0	11.8
Folding Footrest Swingaway	506403	Galvanized Steel		40.0	18.2
Pivot Davit Assembly	506357	Galvanized Steel		8.6	3.9
Pivot Davit Assembly	506506	Stainless Steel		8.6	3.9
Pivot Davit Assembly, Anchorage Ring	506414	Galvanized Steel		9.2	4.2
Roundabout Systems					
Roundabout Assembly	506380	Galvanized Steel		96.3	43.8
Adaptable Column Mounting Assembly	506394	Galvanized Steel		96.3	43.8
Pedestal Assembly	506381	Galvanized Steel		96.3	43.8
Turntable Assembly	506310	Aluminum/ Stainless Steel		6.9	3.1
Pullover Harness	502733	Nylon		3.3	1.5
Pullover Harness	502734	Polyester		3.3	1.5
Dyna-Glide Rescue System	501442	N/A		-	-

Items above are available in stainless steel upon request.
Contact MSA Customer Service Center for ordering information.

Examples of Dyna-Glide Assembly & Applications

LADDER/RAIL COMBINATION ASSEMBLY (LRC) SYSTEM

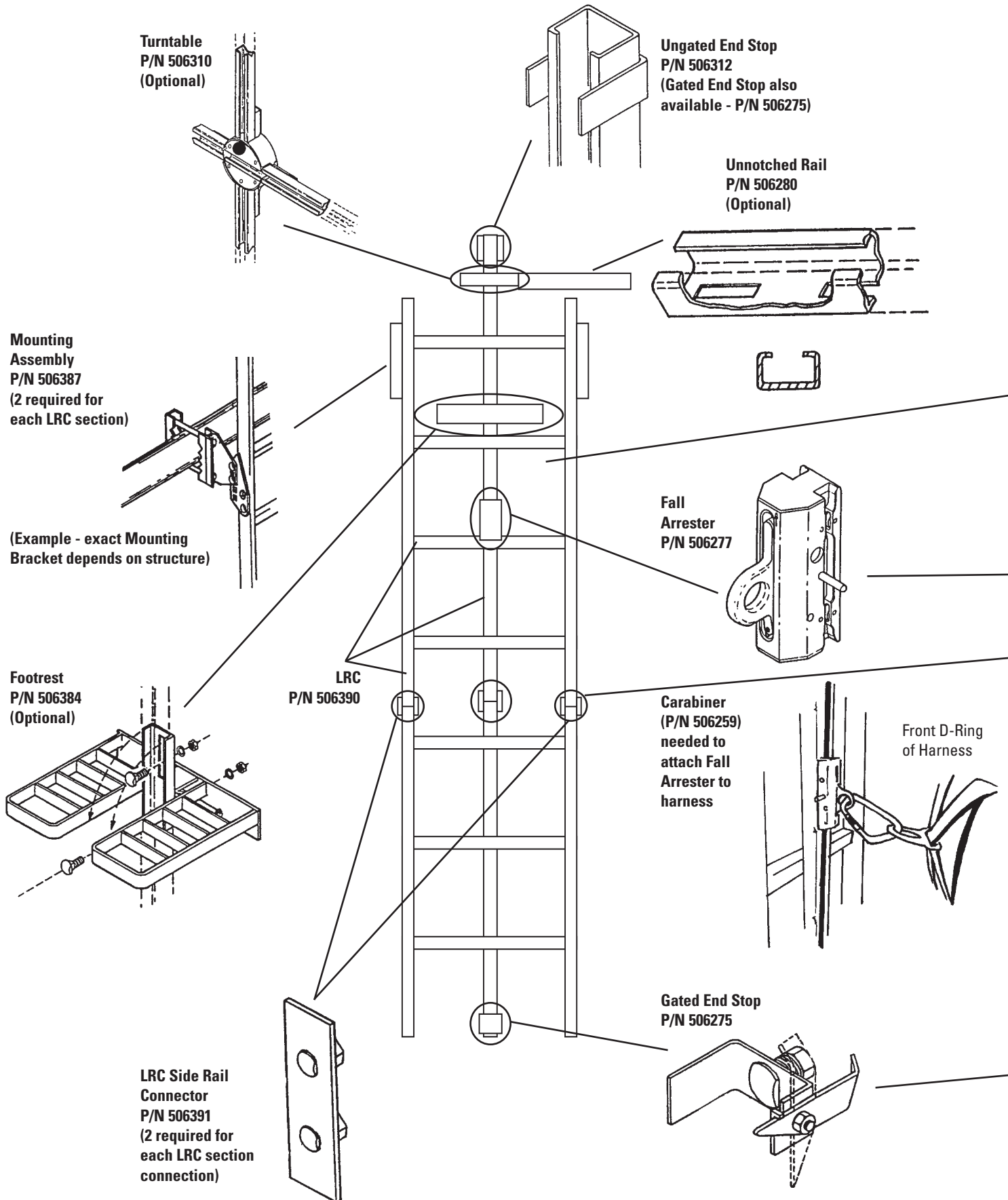

Examples of Dyna-Glide Assembly & Applications

RAIL ONLY SYSTEM ASSEMBLY

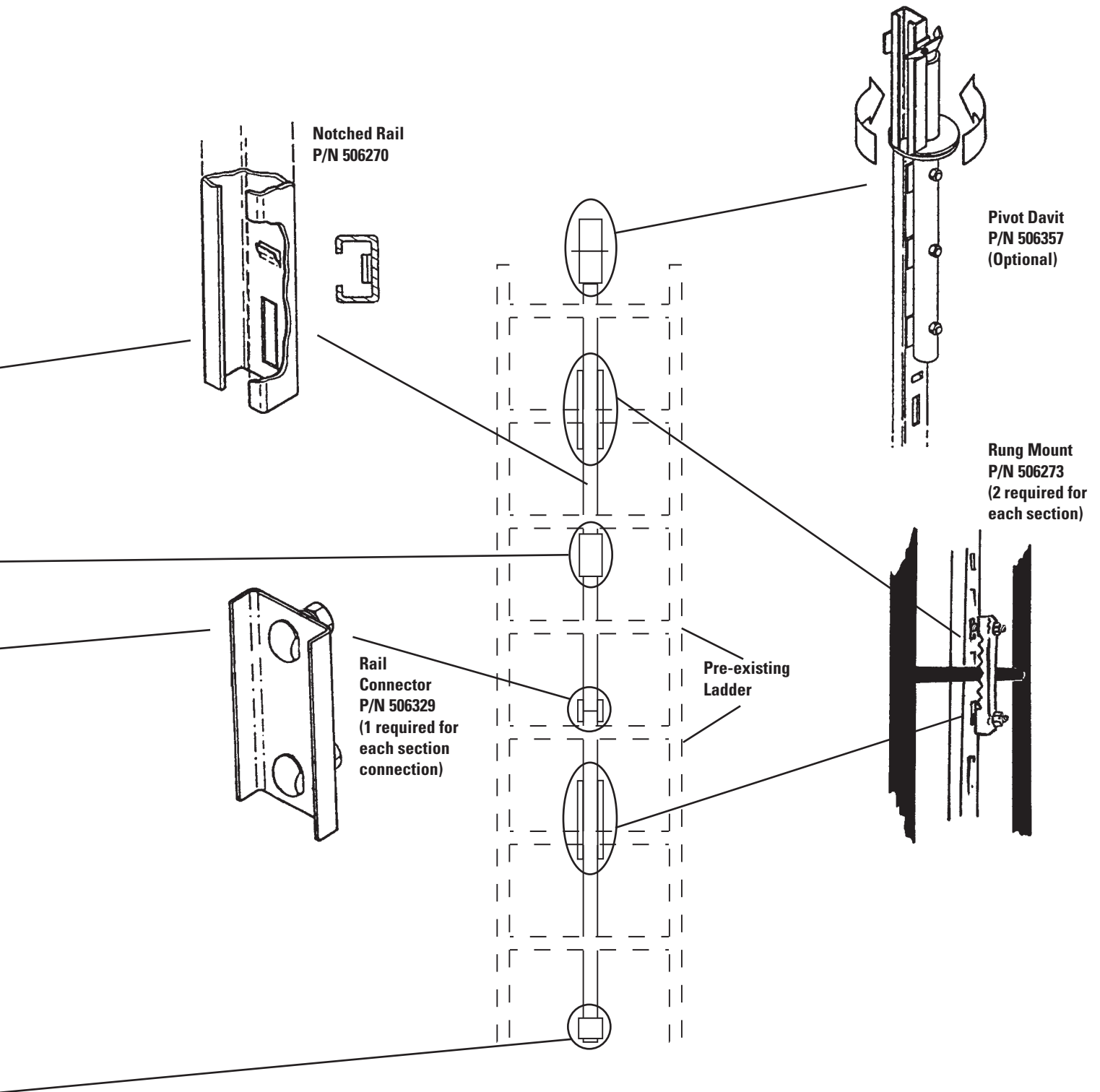

Examples of Dyna-Glide Assembly & Applications

POWER TRANSMISSION TOWER WITH FOUR STRUCTURAL STEEL ANGLE LEGS

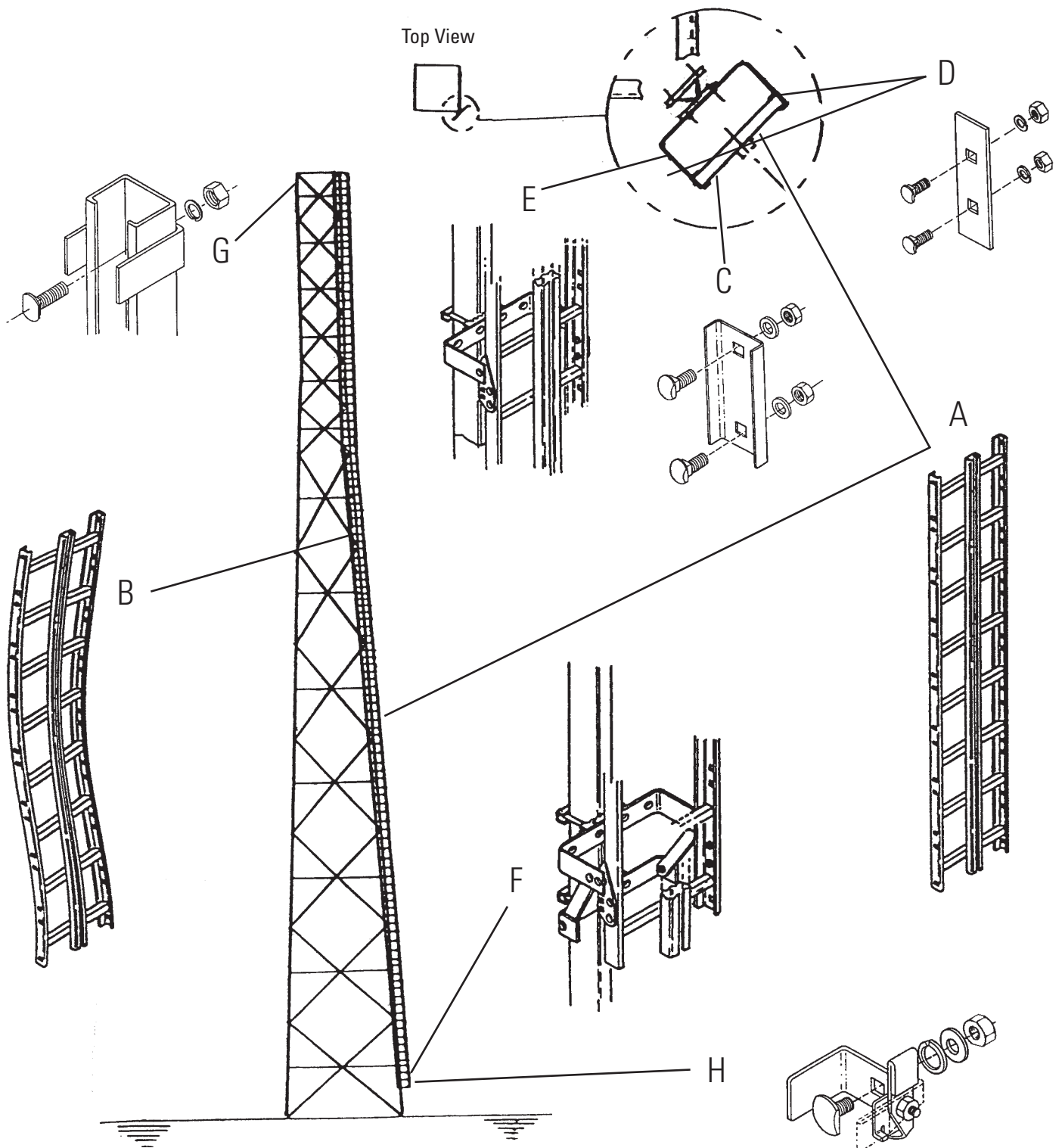

- A. P/N 506390 Ladder/Rail Combination (LRC)
- B. P/N 506491 Ladder/Rail Combination (LRC), Bent Concave
- C. P/N 506329 Rail Connector Assembly
- D. P/N 506391 Ladder Rail Connector Assembly

- E. P/N 506398 Standoff Corner Mounting Assembly
- F. P/N 506400 Standoff Corner Base Mounting Assembly
- G. P/N 506312 Ungated Top End Stop
- H. P/N 506275 Gated Bottom End Stop

Examples of Dyna-Glide Assembly & Applications

POWER TRANSMISSION TOWER WITH FOUR STRUCTURAL STEEL ANGLE LEGS

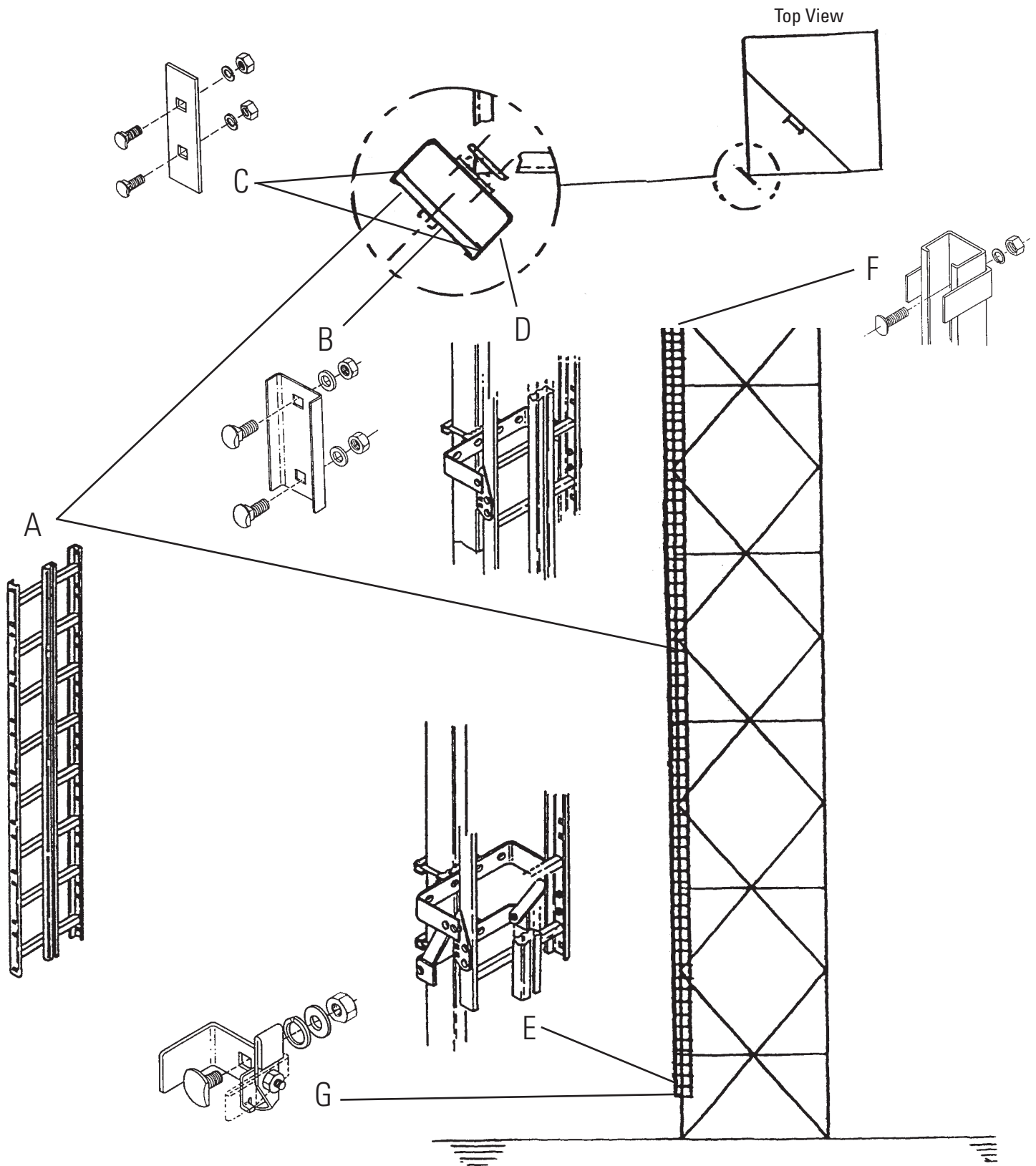

- A. P/N 506390 Ladder/Rail Combination (LRC)
- B. P/N 506329 Rail Connector Assembly
- C. P/N 506391 Ladder Rail Connector Assembly
- D. P/N 506398 Standoff Corner Mounting Assembly

- E. P/N 506400 Standoff Corner Base Mounting Assembly
- F. P/N 506312 Ungated Top End Stop
- G. P/N 506275 Gated Bottom End Stop

Examples of Dyna-Glide Assembly & Applications

POWER TRANSMISSION TOWER WITH THREE LEGS AND INTERNAL LADDER

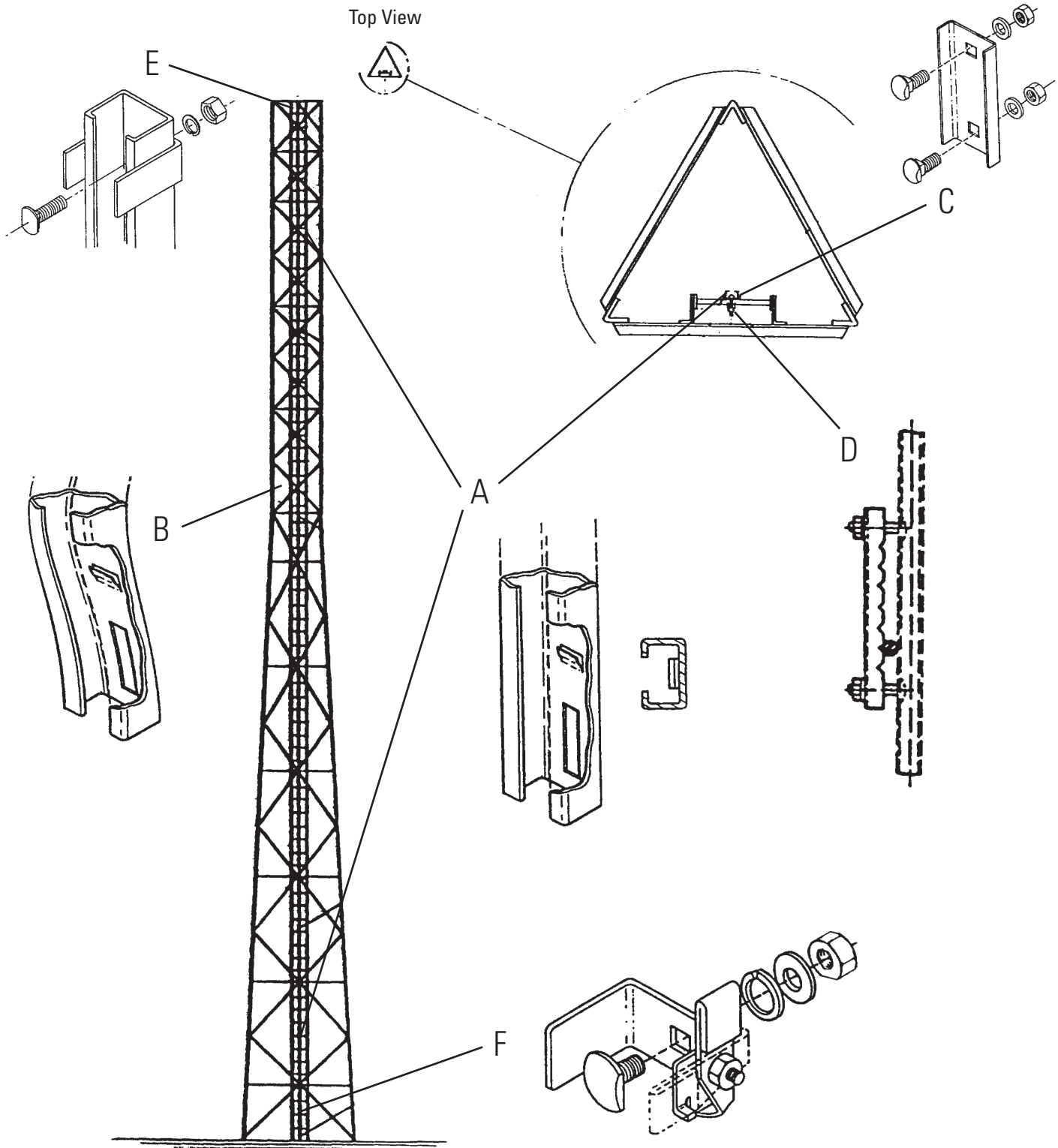

- A. P/N 506270 Rail Section
- B. P/N 506272 Rail Section, Bent Convex
- C. P/N 506329 Rail Connector Assembly

- D. P/N 506273 Rung Mounting Assembly
- E. P/N 506312 Ungated Top End Stop
- F. P/N 506275 Gated Bottom End Stop

Examples of Dyna-Glide Assembly & Applications

WATER TANK/TOWER WITH INTEGRAL LADDER WITHOUT HAND RAIL ON WALKWAY

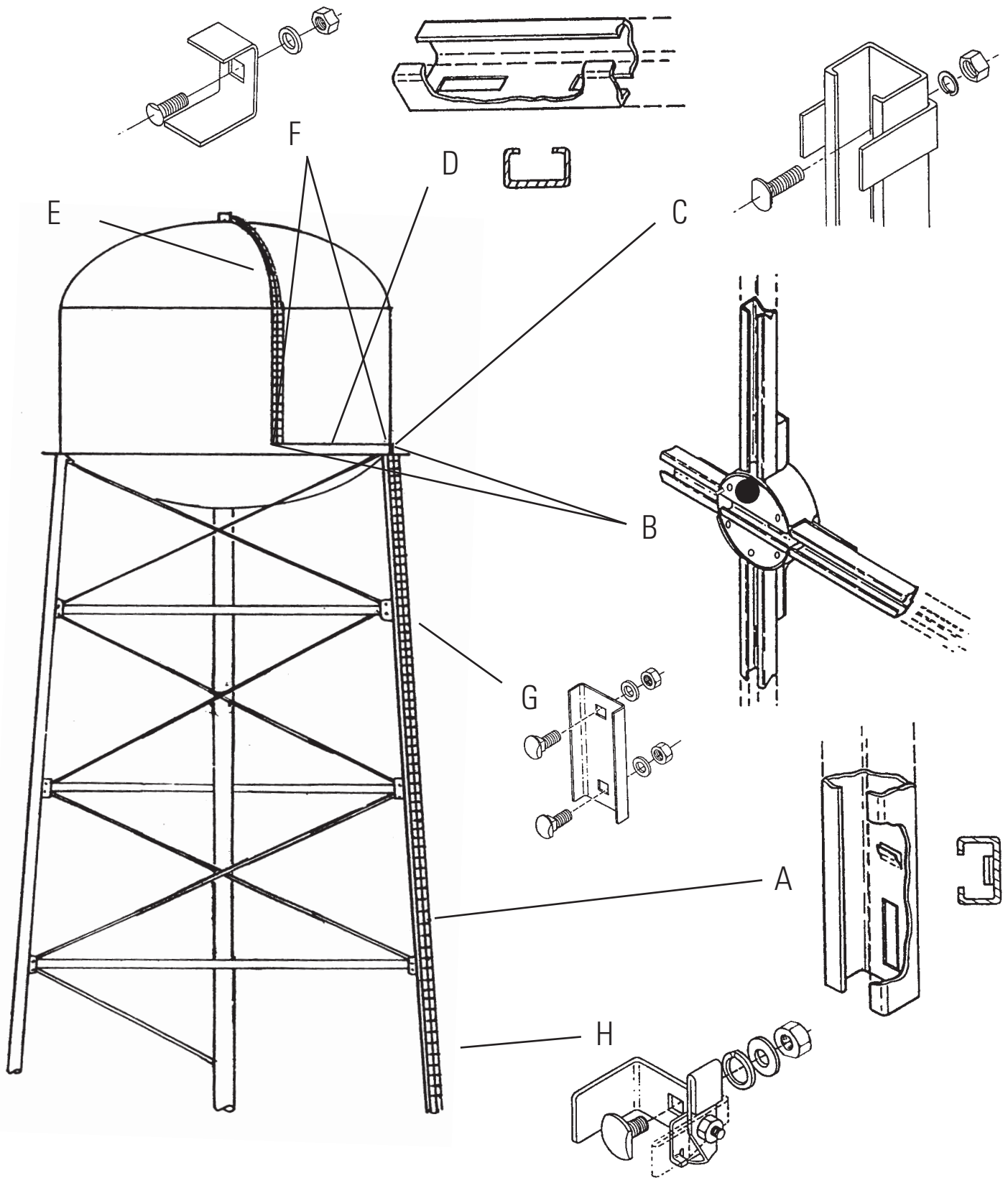

- A. P/N 506270 Rail Section
- B. P/N 506310 Turntable Assembly
- C. P/N 506312 Ungated End Stop Assembly
- D. P/N 506545 Unnotched Curved Rail Section, Bent Convex

- E. P/N 506549 Notched Curved Rail Section, Bent Convex
- F. P/N 506449 Ungated Horizontal End Stop Assembly
- G. P/N 506329 Rail Connector Assembly
- H. P/N 506275 Gated Bottom End Stop

Ordering Considerations

CODES, STANDARDS AND REGULATIONS

It is the buyers responsibility to check with authorities as to all applicable local, state, and Federal codes and regulations pertaining to climbing protection systems and the structures to which they will be attached. Any variances required must be normally obtained by the buyer in advance of installation of a Dyna-Glide system. When properly installed, used and maintained, Dyna-Glide systems and components meet all requirements of USA Federal OSHA and ANSI standard A14.3. Pertinent Federal OSHA regulations are contained in 29 CFR 1910.27, Subpart D-Fixed Ladders, and 29 CFR 1926.450(a)(5), Subpart L-Ladders. Similar (but not necessarily identical) regulations may exist in places outside the jurisdiction of Federal OSHA. This may include certain municipalities, states, public works, maritime, and military facilities. Check with the appropriate authorities. If you are uncertain as to the identity of the prevailing authority and regulations, ask MSA for assistance. Please keep in mind that ladder cages do not prevent or protect against climber falls. Dyna-Glide systems should be considered on ladders even when such ladders have cages.

PLANNING AND EQUIPMENT SELECTION

When planning to purchase a Dyna-Glide system, carefully determine all requirements the system must satisfy. This begins by identifying the places which must be accessed. Then determine the feasible climbing path. If a fixed ladder is in place, this should be considered first. Special attention must be paid to the workplace geometry and the required mobility of the climber. All hazards and obstacles in the climb path must be addressed and be eliminated, documented, or controlled. The strength, location, shape, and orientation of structural members must be determined in order to select the proper Dyna-Glide mounting assemblies. Consider the use of folding footrests at rest places on long climbs or where prolonged work must be performed. Environmental factors (e.g. corrosive atmospheres, ice, confined spaces, etc.) must be identified. Safe landings at the bottom and top of the climb path must be provided for secure mounting and dismounting of the climber. Identify places where lateral movements may necessitate horizontal Dyna-Glide rails and turntables. Overhead protection (from falling objects) must be provided where such hazards exist. Always develop an emergency

rescue and evacuation plan before ordering a system, as there are available devices and techniques for addressing such contingencies. The objective of the Dyna-Glide system design is to provide protection throughout the climber's ascent, descent, and work and to provide for rescue emergencies. The selection of Dyna-Glide mounting brackets, curved rail sections and special accessories should always be done in coordination with a MSA applications engineer. It is the buyer's responsibility to provide accurate and detailed drawings for this to be accomplished. One overlooked detail can result in a very costly experience for the buyer. MSA will not take responsibility for any damage arising out of inadequate specifications. We strongly recommend that the buyer obtain the appropriate instruction manual(s) from MSA for use in planning and selection of the Dyna-Glide system.

INSTALLATION CONSIDERATIONS

The installation personnel should be well-trained, experienced climbers versed in safety at heights, including rescue procedures. It is critical that Dyna-Glide systems be properly installed, or they will not wear well nor function properly or safely. Always be sure the structure to which the system is installed is sound and of sufficient strength to withstand 5,000 pound static loads. Weaker structures must be evaluated by a qualified engineer. MSA will perform turnkey engineering, installation and training services. We assume no responsibility for damages arising out of improperly installed, used or maintained equipment.

INSTRUCTION MANUAL

Every Dyna-Glide system comes with a User Instruction manual which includes installation, use, and maintenance instructions. Always read this manual in advance of installation or, preferably, when planning the system.

IF YOU ARE UNCERTAIN AS TO ANY ASPECT OF DYNA-GLIDE SYSTEMS, OR HAVE ANY QUESTIONS REGARDING THESE SYSTEMS, CONTACT MSA FOR ASSISTANCE.

Part Number Index

10011502.....	16, 17	506381.....	23, 25
10011503.....	16, 17	506384.....	21, 25, 26
501442.....	24, 25	506385.....	8, 10
502733.....	24, 25	506386.....	8, 10
502734.....	24, 25	506387.....	12, 17, 26
506104.....	17	506388.....	14, 17
506230.....	10	506389.....	14, 17
506259.....	20, 25, 26	506390.....	11, 26, 28, 29
506270.....	4, 6, 27, 30, 31	506391.....	18, 25, 26, 28, 29
506272.....	4, 6, 30	506392.....	12, 17
506273.....	7, 10, 27, 30	506394.....	23
506274.....	19, 25	506397.....	14, 17
506275.....	18, 25, 26, 28, 29, 30, 31	506398.....	12, 17, 28, 29
506277.....	20, 25, 26	506399.....	15, 17
506280.....	5, 6, 26	506400.....	13, 17, 28, 29
506281.....	5, 6	506401.....	15
506282.....	10	506402.....	21, 25
506283.....	9, 10	506403.....	22, 25
506286.....	7, 10	506405.....	20, 25
506288.....	4, 6	506408.....	21, 25
506293.....	4, 6	506410.....	15
506307.....	10	506411.....	16, 17
506310.....	23, 25, 26, 31	506414.....	22, 25
506312.....	19, 25, 26, 28, 29, 30, 31	506449.....	31
506318.....	10	506491.....	11, 28
506319.....	10	506500.....	13, 17
506320.....	9	506501.....	13, 17
506321.....	9	506506.....	22, 25
506323.....	4, 6	506513.....	11
506325.....	7, 10	506518.....	12
506326.....	7, 10	506529.....	18, 25
5063282.....	9	506543.....	5, 6
506329.....	18, 25, 27, 28, 29, 30, 31	506544.....	6
506334.....	18, 25	506545.....	5, 6, 31
506337.....	19, 25	506546.....	6
506357.....	22, 25, 27	506548.....	4, 6
506365.....	8, 10	506549.....	4, 6, 31
506380.....	23, 25		

Note: This Bulletin contains only a general description of the products shown. While uses and performance capabilities are described, under no circumstances shall the products be used by untrained or unqualified individuals and not until the product instructions including any warnings or cautions provided have been thoroughly read and understood. Only they contain the complete and detailed information concerning proper use and care of these products.

ID 2300-22-MC / Mar 2007
© MSA 2007 Printed in U.S.A.

Corporate Headquarters
P.O. Box 426, Pittsburgh, PA 15230 USA
Phone 412-967-3000
www.MSAnet.com

U.S. Customer Service Center
Phone 1-800-MSA-2222
Fax 1-800-967-0398

MSA Englewood
2250 South Tejon Street
Englewood, CO 80110-1000

MSA Canada
Phone 416-620-4225
Fax 416-620-9697

MSA Mexico
Phone 52-55 21 22 5770
Fax 52-55 5359 4330

MSA International
Phone 412-967-3354
FAX 412-967-3451

Offices and representatives worldwide
For further information:

