

Instruction Manual

Chillgard[®] RT Refrigerant Monitor



Order No.: 814073/18



WARNING

THIS MANUAL MUST BE CAREFULLY READ BY ALL INDIVIDUALS WHO HAVE OR WILL HAVE THE RESPONSIBILITY FOR INSTALLING, USING OR SERVICING THE PRODUCT. Like any piece of complex equipment, this instrument will perform as designed only if it is installed, used and serviced in accordance with the manufacturer's instructions. OTHERWISE, IT COULD FAIL TO PERFORM AS DESIGNED AND PERSONS WHO RELY ON THIS PRODUCT FOR THEIR SAFETY COULD SUSTAIN SEVERE PERSONAL INJURY OR DEATH.

The warranties made by Mine Safety Appliances Company with respect to the product are voided if the product is not used and serviced in accordance with the instructions in this manual. Please protect yourself and others by following them. We encourage our customers to write or call regarding this equipment prior to use or for any additional information relative to use or repairs.



The Safety Company

1000 Cranberry Woods Drive
Cranberry Township, PA 16066
USA

Schlüsselstrasse 12
8645 Rapperswil-Jona
Switzerland

For your local MSA contacts please go to our website www.MSAsafety.com

MSA Permanent Instrument Warranty

- 1. Warranty-** Seller warrants that this product will be free from mechanical defect or faulty workmanship for a period of eighteen (18) months from date of shipment or one (1) year from installation, whichever occurs first, provided it is maintained and used in accordance with Seller's instructions and/or recommendations. This warranty does not apply to expendable or consumable parts whose normal life expectancy is less than one (1) year such as, but not limited to, non-rechargeable batteries, filament units, filter, lamps, fuses etc. The Seller shall be released from all obligations under this warranty in the event repairs or modifications are made by persons other than its own or authorized service personnel or if the warranty claim results from physical abuse or misuse of the product. No agent, employee or representative of the Seller has any authority to bind the Seller to any affirmation, representation or warranty concerning the goods sold under this contract. Seller makes no warranty concerning components or accessories not manufactured by the Seller, but will pass on to the Purchaser all warranties of manufacturers of such components.

THIS WARRANTY IS IN LIEU OF ALL OTHER WARRANTIES, EXPRESSED, IMPLIED OR STATUTORY, AND IS STRICTLY LIMITED TO THE TERMS HEREOF. SELLER SPECIFICALLY DISCLAIMS ANY WARRANTY OF MERCHANT ABILITY OR OF FITNESS FOR A PARTICULAR PURPOSE.
- 2. Exclusive Remedy-** It is expressly agreed that Purchaser's sole and exclusive remedy for breach of the above warranty, for any tortious conduct of Seller, or for any other cause of action, shall be the repair and/or replacement at Seller's option, of any equipment or parts thereof, which after examination by Seller is proven to be defective. Replacement equipment and/or parts will be provided at no cost to Purchaser, F.O.B. Seller's Plant. Failure of Seller to successfully repair any non-conforming product shall not cause the remedy established hereby to fail of its essential purpose.
- 3. Exclusion of Consequential Damage-** Purchaser specifically understands and agrees that under no circumstances will seller be liable to purchaser for economic, special, incidental or consequential damages or losses of any kind whatsoever, including but not limited to, loss of anticipated profits and any other loss caused by reason of non-operation of the goods. This exclusion is applicable to claims for breach of warranty, tortious conduct or any other cause of action against seller.

General Warnings and Cautions

WARNING

1. The monitor and Relay Module described in this manual must be installed, operated, and maintained in strict accordance with the labels, cautions, warnings, instructions, and within the limitations stated.
2. The monitor must not be installed in outdoor areas or in locations where explosive concentrations of combustible gases or vapors might occur in the atmosphere: Class I, Group A, B, C, and D areas as defined by the NEC. Because the monitor is not explosion-proof, it must be located in non-hazardous areas.
3. The Chillgard RT Refrigerant Monitor is designed to detect one particular refrigerant gas or vapor at ambient atmospheric pressures. The unit will not detect refrigerant gas at elevated temperatures.
4. High levels of or long exposure to certain compounds in the tested atmosphere may contaminate the sensor. In atmospheres where the system may be exposed to such materials, perform calibration frequently to ensure dependable system operation and accurate indications.
5. Do not paint the Chillgard RT System. Also, do not paint near any of the sample line inlets to ensure paint is not deposited on the sample inlet fitting of the units. Such paint deposits would interfere with the sampling process, whereby a sample of the atmosphere being monitored is drawn into the Chillgard RT System.
6. The only absolute method to assure the proper overall operation of a gas detection instrument is to check it with a known concentration of the gas for which it has been calibrated. Consequently, a calibration check must be included as part of the installation and as a routine inspection of the system.
7. Perform periodic leak checks on all the sample lines and all flow system components and fittings of the Chillgard RT System.
8. Use only genuine MSA replacement parts when performing any maintenance procedures provided in this manual. Failure to do so may impair instrument performance. Repair or alteration of the Chillgard RT System, beyond the scope of these maintenance instructions or by anyone other than authorized MSA service personnel, could cause the product to fail to perform as designed, and persons who rely on this product for their safety could sustain serious personal injury or death.

9. Properly vent the exhaust of the Chillgard RT System to a safe area. Improper venting of the exhaust may cause serious personal injury or death.
10. Ensure the gas sample to the system is clean and non-condensing. Install end-of-line filters in all sample inlet lines.
11. Avoid any installation where condensation may form. Condensation may possibly clog or block the sampling line; this will prevent the instrument from receiving new or fresh gas samples from the area being monitored.
12. The Chillgard RT Refrigerant Monitor must be installed, located and operated in accordance to all applicable codes. These codes include, but are not limited to, the National Fire Prevention Code and National Electric Code.
13. The Chillgard RT Relay Module must be connected to proper main voltages. Connection of improper voltages will cause the unit to fail. The Chillgard RT Relay Module uses the same electrical ground as the RT Monitor.
14. Protect the Chillgard RT Relay Module from vibration and heating; otherwise, improper operation may result, which can result in personal injury or death.
15. Do not exceed the relay contact ratings listed in Appendix B, TABLE B-1. Otherwise, relay operation may fail, which can result in personal injury or death.

Failure to comply with the above warnings can result in serious personal injury or death.



CAUTION

1. Do not attempt to modify or adjust the sensing element.

Table of Contents

Chapter 1	
General Information	1-1
Introduction	1-1
Table 1-1. Chillgard RT System	
General Operating Specifications.....	1-2
Identifying Your Unit	1-3
Multipoint Sequencer	1-3
Figure 1-1. Identifying your Unit	1-4
Figure 1-2. Single Point Sequencer Unit.....	1-5
Figure 1-3. Four Point Sequencer Unit.....	1-5
Figure 1-4. Eight Point Sequencer Unit.....	1-5
Beacon	1-6
End of Sample Line Filters	1-6
General Description.....	1-6
The Chillgard RT Unit:	1-6
Figure 1-5. Chillgard RT Monitor	
with Optional Beacon	1-6
The Internal Multipoint Sequencer Unit:	1-7
Terminology	1-8
Applications	1-9
Sensor Selectivity*	1-9
Table 1-2. Typical Chillgard RT System for	
R-11 Cross-Sensitivity Response Data	1-9
Table 1-3. Typical Chillgard RT System for	
R-12 Cross-Sensitivity Response Data.....	1-10
Table 1-4. Typical Chillgard RT System for	
R-22 Cross-Sensitivity Response Data.....	1-10
Table 1-5. Typical Chillgard RT System for	
R-123 Cross-Sensitivity Response Data.....	1-11
Table 1-6. Typical Chillgard RT System for	
R-134a Cross-Sensitivity Response Data.....	1-11
Table 1-7. Typical Chillgard RT System for	
R-113 Cross-Sensitivity Response Data	1-12
Table 1-8. Typical Chillgard RT System for	
R-114 Cross-Sensitivity Response Data	1-12

Table 1-9. Typical Chillgard RT System for R-500 Cross-Sensitivity Response Data.....	1-12
Table 1-10. Typical Chillgard RT System for R-502 Cross-Sensitivity Response Data.....	1-13
Table 1-11. Typical Chillgard RT System for Ammonia* Cross-Sensitivity Response Data.....	1-13
Table 1-12. Typical Chillgard RT System for R-404a Cross-Sensitivity Response Data.....	1-14

**Chapter 2
Installation and Set-up..... 2-1**

Receiving	2-1
Unpacking the System	2-1
Initial Inspection	2-1
WARNING	2-1
Location of the Monitor.....	2-2
Instrument Location Guidelines	2-2
WARNING	2-2
Figure 2-1. Front Door Latches	2-2
Guidelines for Locating the Sampling Point(s).....	2-3
Equipment Configuration	2-3
Figure 2-2. Typical Monitor Installation.....	2-4
Activity in the Room	2-5
CAUTION	2-5
Mounting the Unit	2-6
Sample System Installation	2-6
WARNING	2-6
WARNING	2-6
Wiring Connections	2-7
Opening the Unit.....	2-7
CAUTION	2-7
CAUTION	2-7
Figure 2-3a. Mounting Dimensions.....	2-8
Figure 2-3b. Mounting Dimensions.....	2-9
Unit Power Wiring.....	2-10
Power Supply Wiring	2-10
CAUTION	2-10
Figure 2-4. Primary Power Wiring	2-10

Wiring the Chillgard RT Unit	2-11
Analog Signal Output Wiring (FIGURE 2-5).....	2-11
4-20 mA	2-11
0-10 VDC	2-11
RS 232 Output	2-12
Figure 2-5. Wiring Connections	2-12
Ferrite Bead Installation	2-13
Figure 2-6. Ferrite Bead Installation	2-13
CAUTION	2-13
Optional Alarm Beacon	2-14
Relay Outputs	2-14
Alarm Relays.....	2-14
Trouble Relay.....	2-15
Trouble Relay Connection Wiring	2-15
Remote Reset.....	2-15
Audible Alarm Output.....	2-16
Auxiliary Input - Use UL Listed Devices	2-16
Initial Calibration	2-16
CAUTION	2-16
Multipoint Sequencer Operation.....	2-17

Chapter 3

Start-up and Initial Adjustments 3-1

Figure 3-1a. Display Screen Overview	3-2
Figure 3-1b. Display Screen Overview Continued	3-3
Figure 3-2a. Start-up and Normal Operation Screens.....	3-4
Figure 3-2b. Start-up and Normal Operation Screens Continued	3-5
Figure 3-3a. Setup Screens.....	3-6
Figure 3-3b. Setup Screens Continued	3-7
Figure 3-4. Span Calibration	3-8
Figure 3-5. Zero Calibration.....	3-9
Figure 3-6. Check Calibration	3-10
Figure 3-7. Diagnostic Screens	3-11
Figure 3-8. Diagnostic Screens	3-12
Figure 3-9. Diagnostic Screens	3-13
Figure 3-10. Data Screens.....	3-14

Figure 3-11. Sequencer Set-up Screen	3-15
Figure 3-12. Sequencer Set-up Screen	3-16
Figure 3-13. Alarm Level Screen	3-17
Figure 3-14. Alarm Latching Screen	3-18
Figure 3-15. Alarm Latching Screen	3-19
Figure 3-16. Audio Alarm Screen.....	3-20
Figure 3-17. Analog Output Screen	3-21
Figure 3-18. Aux Alarm Screen.....	3-22
Figure 3-19. Auxiliary Alarm Screen	3-23
Figure 3-20. Setup Time	3-24
Figure 3-21. Setup Log	3-25
Figure 3-22. Setup Password	3-26
Figure 3-23. Review Log.....	3-27
Figure 3-24. Review Data	3-28

Chapter 4
Calibration 4-1

Introduction	4-1
Calibration Equipment	4-2
Equipment needed:.....	4-2
Figure 4-1. Kit Components.....	4-2
Table 4-1. RP Calibration Gases.....	4-3
Chillgard RT identification.....	4-3
CAUTION	4-3
Figure 4-2. Chillgard RT Models.....	4-4
Calibration Procedures	4-5
Table 4-2. Calibration Sequence Screens	4-5
Figure 4-3a. Zero Calibration	4-6
Figure 4-3b. Zero Calibration Continued	4-7
Figure 4-4. SPAN Calibration.....	4-8
Figure 4-5. Ammonia or R-404a Unit Calibration	4-8
WARNING	4-9

**Chapter 5
Maintenance 5-1**

General Maintenance 5-1
Obtaining Replacement Parts 5-1
 WARNING 5-1
 Table 5-1. Replacement Parts 5-2
Troubleshooting Guidelines (see TABLE 5-2) 5-3
 Table 5-2. Troubleshooting Guidelines 5-3

**Chapter 6
Data Logging 6-1**

Log Size 6-1
Last Values 6-1
Number of Data Points Used 6-1
User Setup Options 6-1
Viewing Alarms/Events and Data 6-1

**Appendix A
Check List A-1**

**Appendix B
Relay Module B-1**

General Description B-1
 Figure B-1. Relay B-1
 Figure B-2. Mounting the Relay Module B-2
Specifications B-3
 Table B-1. Specifications B-3
 Figure B-3. Relay Module Main Power Connector
 and Communication Cable Connector
 Locations B-3
 Communication Cable Connections B-4
 Figure B-4. Chillgard RT Relay Module Power
 Wiring Diagrams for 120 Volts and
 240 Volts B-4
 Figure B-5. Chillgard RT Refrigerant Monitor B-4

Figure B-6. Typical Interface Modules.....	B-5
Unpacking the Shipping Carton	B-6
Identifying the Unit	B-6
Table B-2. Part Numbers and Supplied Relays	B-6
Mounting Your Unit	B-6
Electrical Connections for the Chillgard RT	
Relay Module	B-6
Main Power Connections	B-6
CAUTION	B-6
Communication Cable Connections	B-7
WARNING	B-7
CAUTION	B-7
WARNING	B-7
Communication Cable Connections	
to the Chillgard RT Relay Module	B-8
Communication Cable Connections	
to the Chillgard RT Refrigerant Monitor	B-8
Relay Wiring	B-8
Operation	B-9
Front Panel	B-9
Power	B-9
Trouble	B-9
CAUTION	B-9
WARNING	B-9
Ready Indicator	B-10
Chillgard RT Relay Module Relays	B-10
The Common Horn Relay	B-10
The Trouble Relay	B-10
The Discrete Caution, Warning and Alarm Relays	B-11
Applying Power	B-11
Alarm Relay Configuration	B-11
Latching	B-11
Normally Energized/De-energized	B-11
Operation	B-12
Reset Switch	B-12
Trouble Relay	B-12
Horn Operation	B-13
Configuration	B-13
Reset Switch	B-13

Maintenance.....	B-13
Troubleshooting	B-14
Table B-3. Troubleshooting	B-14
Obtaining Replacement Parts.....	B-14
Table B-4. Replacement Parts	B-14

Appendix C
RS-232 Output C-1

Introduction.....	C-1
Figure C-1. RS-232 Location	
Table C-1. RS-232 Parameters.....	C-2
Three types of messages can be transmitted from the RS-232 port:	C-2
Status.....	C-3
Data Logged Value.....	C-3
Alarm Events	C-3
Table C-2. Status Message	C-4
Table C-3. Data Logging	C-5
RS-232 Output	C-6
Table C-4. Alarm Logging.....	C-6
Figure C-2. Typical RS-232 Wiring	C-7
Remote Gas Sampling Channel Identification	C-8
Table C-5. Voltage Output Corresponds to Channel	C-8

Appendix D
Multi-refrigerant Capability* D-1

Introduction.....	D-1
Specifications	D-1
Table D-1*. Multi-Refrigerant Chillgard RT Refrigerant Monitor	D-1
Table D-2. Typical Cross Sensitivity at 100 Parts Per Million (PPM) at 25°C for the Chillgard RT Refrigerant Monitor Calibrated at 1000 PPM R11 as Expressed in Response Factors	D-2
Identifying Your Unit	D-2

Installation	D-2
Figure D-1. Label and RS-232 Location	D-3
Figure D-2. Calibration Label	D-4
Figure D-3. Manufacture Date Label	D-4
Initial Setup	D-5
Calibration	D-5
Display Screens	D-5
WARNING	D-5
Figure D-4. Gas by Point Setup Screens	D-7
Figure D-5. Alarm Level Screens	D-8
Figure D-6a. Alarm Level Screens	D-9
Figure D-6b. Alarm Level Screens	D-10

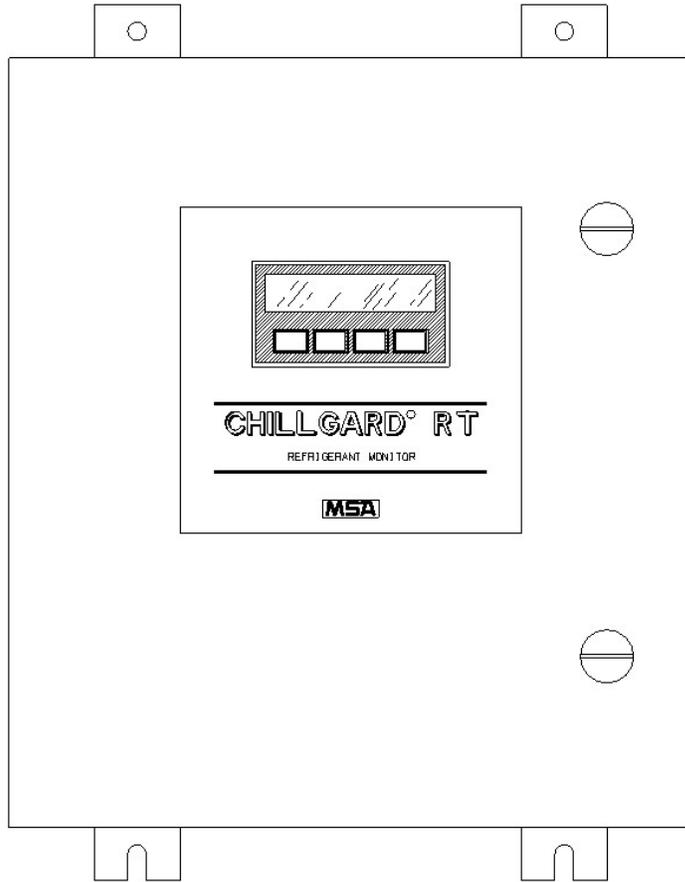

Chillgard RT Refrigerant Monitor

Chapter 1

General Information

Introduction

This manual provides instructions for the:

- Chillgard RT Monitor
- Chillgard RT unit with Multipoint Sequencer.

These instruments can provide continuous refrigerant gas monitoring (see TABLE 1-1 for Operating Specifications).

All units listed below have been evaluated by Underwriters Laboratory. The ammonia units have not been evaluated by Underwriters Laboratories, Inc.

CHILLGARD RT MONITORS EVALUATED BY UNDERWRITERS LABORATORIES, INC.	
R-11	R-502
R-12	R-123
R-113	R-22
R-114	R-134a
R-500	R-404a

Table 1-1. Chillgard RT System General Operating Specifications

PERFORMANCE SPECIFICATIONS	
STABILITY	0-50 ppm, +1 ppm; ammonia is 2 ppm 51-1000 ppm, +10% of reading
SHORT TERM NOISE	+1 ppm peak over a 10-minute period; ammonia* is +2 ppm
LINEARITY	0-50 ppm +1 ppm; ammonia* is +2 ppm 51-1000 ppm, +10% of reading
WARM-UP TIME (READY)	24 hours maximum; typical, 20 minutes at 70°F (21°C) ambient
RESPONSE TIME	90% of a step-change and alarm condition within 110 seconds
TRANSPORT TIME	500 FT (152 M) OF SAMPLING TUBING LENGTH 13 minutes for a 90% step change 150 FT (46 M) OF SAMPLING TUBING LENGTH 105 seconds for a 90% step change
OPERATING TEMPERATURES	0°C to 50°C (32°F to 122°F)
TEMPERATURE EFFECT	+0.3%/°C of reading, +0.1 ppm/°C
RELATIVE HUMIDITY	0 to 95%, RH non-condensing
SAMPLE FLOW RATE	.75 liter per minute - minimum with maximum tubing length; typically 1.2 to 1.5 liters per minute with no tubing
MAXIMUM SAMPLE OR EXHAUST TUBING LENGTH	150 feet (46 m) with 1/8" (3.2 mm) ID tubing, 1/4" (6.4 mm) OD (total of Inlet & Outlet); 500 feet (152 m) with 0.18" (4.6 mm) ID tubing
OPERATING PRESSURE	ambient atmospheric
OPERATING SPECIFICATIONS	
VOLTAGE RATING	100 to 240 VAC, 50-60 Hz
POWER REQUIREMENTS	.88 amps at 120 VAC; .54 amps at 240 VAC
TROUBLE RELAY	Normally energized, Form C contact: 240 VAC, 8 amp resistive SPDT
WARNING RELAY	One relay, Form C contacts: 240 VAC, 8 amps resistive SPDT
CAUTION RELAY	One relay, Form C contacts: 240 VAC, 8 amps resistive SPDT
ALARM RELAY	One relay, Form C contacts: 240 VAC, 8 amps resistive SPDT
ANALOG OUTPUTS	4 to 20 mA sourcing, 1,000 ohm load, 0-10 V, 2 K ohm load
MAXIMUM OUTPUT SIGNAL LOAD FOR 4-20 MA OUTPUT	1000 ohms (includes wiring)
AUDIO ALARM DRIVE OUTPUT	10 VDC 20-ohm load maximum (available only with non-beacon models)
SAMPLE TUBING CONNECTIONS	1/4" (6.4 mm) OD
DIMENSIONS	18" high, 16" wide, 7" deep 45.7 cm high, 40.6 cm wide, 17.8 cm deep

WEIGHT OF CHILLGARD RT WITH SEQUENCER	45 pounds (20 kg)
TRANSPORT AND STORAGE CONDITIONS	
TEMPERATURE	-67°F to 158°F (-55°C to +70°C)
HUMIDITY	99% RH non-condensing
*This unit has not been evaluated by Underwriters Laboratories, Inc.	
**For UL2075 testing from 50°C to 61°C, the Temperature Effect is +0.6%/°C of reading and +1 ppm/°C	
For the Chillgard RT Remote Relay* unit option, see Appendix B, "Relay Module."	

The Chillgard RT Monitor is intended for indoor use in mechanical equipment rooms housing air conditioning or refrigeration equipment or for use in areas where bulk refrigerants are stored.

The monitor uses infrared sensing technology, allowing accurate measurement of refrigerant vapors with minimum interference from other vapors. Your Chillgard RT unit is factory-calibrated for a specific refrigerant. It is extremely sensitive, capable of measuring down to 1 part per million (ppm). The unit monitors the signal and can operate three alarm levels at software-selectable gas concentration values. There is also a trouble indication to alert the operator when something is wrong with the unit.

Identifying Your Unit

Multipoint Sequencer

The Chillgard RT Refrigerant Monitor is capable of monitoring different types of refrigerants. However, each unit is factory-calibrated to detect one type of refrigerant.

Check the label inside the front door to determine what gas your unit is designed to detect (FIGURE 1-1). For specific guidelines on using the RS232 function (serial communication port), see Appendix C. For specific guidelines on the multi-refrigerant version of the Chillgard RT Monitor, see Appendix D.

The unit monitors only one zone or location, but your instrument may contain a Multipoint Sequencer capable of monitoring up to four or eight different zones or locations. To determine the number of sampling locations your particular unit is able to monitor, carefully tilt the unit and count the number of inlet ports at the bottom of the case (FIGURE 1-2, 1-3 or 1-4).

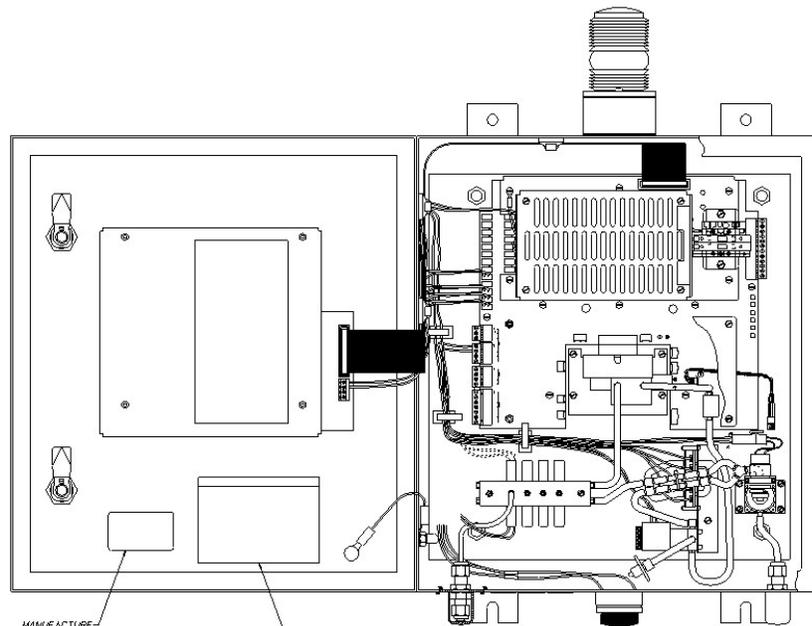

MANUFACTURE
DATE LABEL

Factory Performance Test/Verification	
Calibration Gas Mixture:	_____
Synthetic Span:	_____
MSA Cylinder P/N:	_____
Cylinder Reading:	_____
Certified Sensitivity Range:	_____
Certified Accuracy:	<u>See Installation Literature Specifications</u>
Test Date:	_____
Test Reference Number:	<u>See Unit Serial Number</u>
Instruction Manual Revision Number:	_____
Inspector:	_____

Factory Performance Test/Verification	
Calibration Gas Mixture:	_____
Synthetic Span:	_____
MSA Cylinder P/N:	_____
Cylinder Reading:	_____
Certified Sensitivity Range:	_____
Certified Accuracy:	<u>See Installation Literature Specifications</u>
Test Date:	_____
Test Reference Number:	<u>See Unit Serial Number</u>
Instruction Manual Revision Number:	_____
Inspector:	_____

Figure 1-1. Identifying your Unit

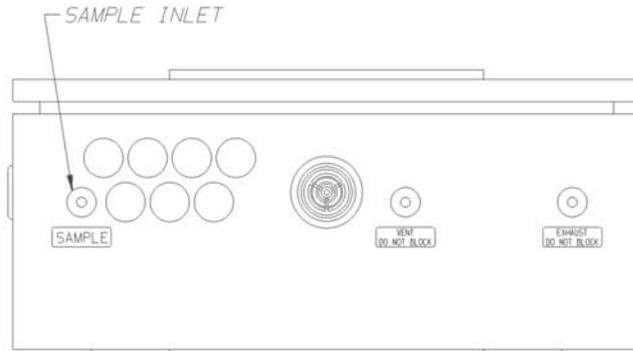

Figure 1-2. Single Point Sequencer Unit

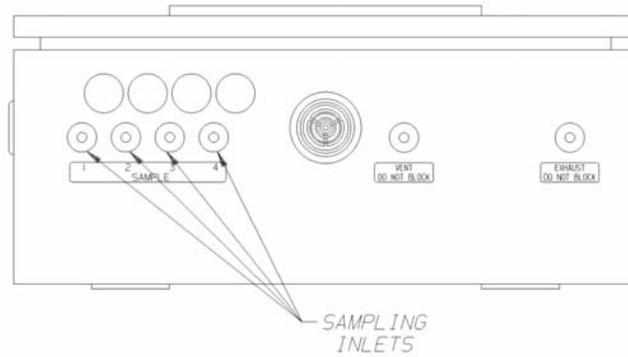

Figure 1-3. Four Point Sequencer Unit

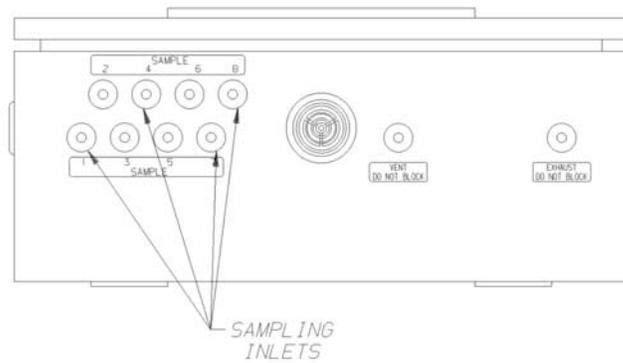

Figure 1-4. Eight Point Sequencer Unit

Beacon

The optional beacon is mounted on top of the unit (FIGURE 1-5). It is powered by the monitor's internal DC voltage.

End of Sample Line Filters

End of sample line filters are required for proper unit operation; they may be included in the shipping carton.

If the end of sample line filters are not included, they must be purchased. Place an end-of-sample line filter (P/N 711561).

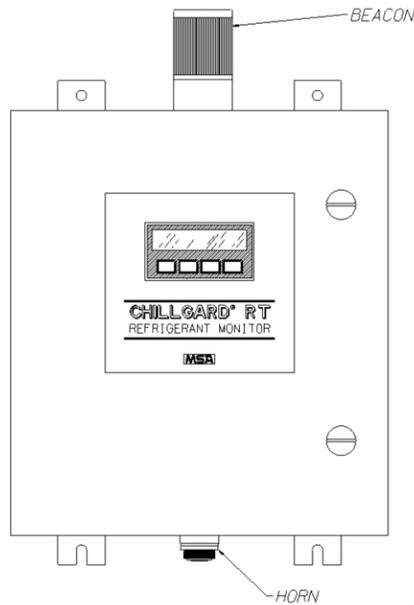

Figure 1-5. Chillgard RT Monitor with Optional Beacon

General Description

The Chillgard RT Unit:

- Monitors refrigerant gases up to 1000 parts-per-million (ppm)
- Operates on the photo-acoustic principle, allowing refrigerant gas concentration measurement in a complex mixture of background gases

- Allows refrigerant gas detection in applications where contaminants or interferants preclude use of other techniques
- Provides a digital display; if it is a multi-point monitor, it also shows the point number currently being sampled by the unit
- Is also used for applications requiring long-term stability and low maintenance
- Is factory-calibrated to the full scale value of refrigerant gas
- Is compensated for the relative humidity of the gas to give excellent zero stability and enable alarms at refrigerant gas levels as low as 3 ppm.
- Operates over a wide temperature range
- Has front-panel windows for viewing:
 - Gas concentration
 - Diagnostics
 - Alarm Conditions
- Is highly selective to enable operation in:
 - Areas with varying humidity
 - Areas containing other contaminants.
- Comes standard with:
 - Four sets of relay contacts
 - Two completely independent outputs:
 - 0-10 V
 - 4-20 mA
- One input: 4-20 mA, assignable to the ALARM relay
- RS 232 output (see Appendix C for more information).

The Internal Multipoint Sequencer Unit:

- Allows a single Chillgard RT unit to monitor up to four or eight areas or locations, if equipped
- Each point is capable of sampling from remote areas up to 500 feet (152 m) from the Chillgard RT unit
- Contains all necessary flow components (excluding end-of-line filter and sampling line) to properly sample four or eight areas and indicate the gas or vapor concentrations.

Terminology

Become familiar with the following terminology.

ZERO- A zero (0) indication on the meter display usually indicates fresh air (no refrigerant gas present).

ZEROING- The process of placing a zero gas on the unit during calibration.

SPAN- Full-scale or up-scale reading on meter display.

SPANNING- The process of placing a full-scale or span gas on the unit during calibration.

SPAN GAS VALUE- The gas concentration that gives the instrument a full-scale or up-scale value. This value is printed on the calibration gas cylinder containing the gas.

FLOW RATE- Volume of gas drawn through the sample line per minute.

EXHAUST GAS- Sample gas after it passes through the sensor.

PUMP- The electric motor driven device that moves the gas sample to the Chillgard RT Monitor.

ALARMS- The Chillgard RT System has three alarms to alert the user at specific, user-adjustable refrigerant gas concentrations. (Level 1 = Caution, Level 2 = Warning and Level 3 = Alarm.)

RELATIVE HUMIDITY- The percent of water vapor saturation in air at a given temperature.

POINT NUMBER- The location or area from which a gas sample is drawn. Up to four or eight areas, sequentially numbered from 1 to 8, can be sampled.

BYPASS- The Sequencer is a look-ahead system; bypass gas flow is drawn from the next area to be sampled. This feature reduces the monitor response time when long sampling lines are used.

FRESH AIR- Air that has no possibility of containing refrigerant gas.

TEMPERATURE EFFECT- The gas response displayed by the instrument (PPM) can change +0.3% for each degree (C) that the instrument is operating above/below the temperature at which the instrument was last calibrated.

Applications

The Chillgard RT Monitor is factory-calibrated for a particular refrigerant gas. When calibrated, the Chillgard RT System is used in a wide variety of industrial applications, such as:

- detection of refrigerant gases leaking into the atmosphere
- ambient air monitoring for health and safety purposes

Sensor Selectivity*

The Chillgard RT Refrigerant Monitor is factory-calibrated for your particular refrigerant gas (TABLE 1-3). The system is highly selective to refrigerant gases in air; however, the system also responds to other gases (interferants). See TABLES 1-2 through 1-11* for typical cross-sensitivities. Actual cross-sensitivities vary from instrument to instrument. *Typical cross-sensitivities not verified or investigated by UL.

NOTE: These cross-sensitivity values do not apply to a multi-refrigerant unit where the optics have been adjusted to detect a variety of refrigerants.

If it is not known whether the gas to be detected is an interferant gas, contact MSA at **1-800-MSA-INST**.

Table 1-2. Typical Chillgard RT System for R-11 Cross-Sensitivity Response Data

GAS	CONCENTRATION (PPM)	EQUIVALENT PPM R-11
Acetone	100	14
Methyl Ethyl Ketone	100	32
Methanol	1000	130
iso-Propanol	500	400
Methylene Chloride	100	0
Xylene	100	0
Ammonia	50	0
R 113	100	25
R 11	100	100
R 22	100	30
R 12	983	490
R 134 A	100	20
R 123	100	3
Propane	0.6%	18
Ethylene	500	20
TEST CONDITIONS:	Calibrated 0-1000 PPM R-11 in N ₂ ; Temperature: 25°C	

Table 1-3. Typical Chillgard RT System for R-11 Cross-Sensitivity Response Data

GAS	CONCENTRATION (PPM)	EQUIVALENT PPM R-12
Acetone	100	3
Methyl Ethyl Ketone	1000	25
Methanol	1000	2
Methylene Chloride	1000	14
Trichloroethylene	1000	167
Ethyl Acetate	1000	22
Xylene (ortho-Xylene)	1000	5
R113	100	35
R11	100	5
R22	100	1
R12	100	100
R134A	100	2
R114	100	45
TEST CONDITIONS:	Calibrated 0-1000 PPM R-12 in N ₂ ; Temperature - 25°C	

Table 1-4. Typical Chillgard RT System for R-22 Cross-Sensitivity Response Data

GAS	CONCENTRATION (PPM)	EQUIVALENT PPM R-22
Acetone	100	<1
R11	100	16
R123	100	35
R134A	100	25
R1132A	100	40
R22	100	100
R113	100	39
TEST CONDITIONS:	Calibrated 0-1000 PPM R-22 in N ₂ ; Temperature: 25°C	

Table 1-5. Typical Chillgard RT System for R-123 Cross-Sensitivity Response Data

GAS	CONCENTRATION (PPM)	EQUIVALENT PPM R-123
Acetone	100	22
Methyl Ethyl Ketone	500	48
Methanol	100	2
iso-Propanol	100	5
Methylene Chloride	1000	14
Trichloroethylene	1000	4
Ethyl Acetate	100	42
Xylene (ortho-Xylene)	1000	5
Ammonia	910	7
Natural Gas	1000	5
R113	100	80
R11	100	<1
R22	100	4
R12	100	8
R134A	100	140
R123	100	100
TEST CONDITIONS:	Calibrated 0-1000 PPM R-123 in N ₂ ; Temperature: 25°C	

Table 1-6. Typical Chillgard RT System for R-134a Cross-Sensitivity Response Data

GAS	CONCENTRATION (PPM)	EQUIVALENT PPM R-134a
R113	100	17
R11	100	2
R22	100	1
R134A	100	100
R123	100	8
TEST CONDITIONS:	Calibrated 0-1000 PPM R-134a in N ₂ ; Temperature: 25°C	

Table 1-7. Typical Chillgard RT System for R-113 Cross-Sensitivity Response Data

GAS	CONCENTRATION (PPM)	EQUIVALENT PPM R-113
R11	100	1
R12	100	10
R22	100	5
R123	100	125
R134A	100	175
R114	100	155
R113	100	100
TEST CONDITIONS:	Calibrated 0-1000 PPM R-113 in N ₂ ; Temperature: 25°C	

Table 1-8. Typical Chillgard RT System for R-113 Cross-Sensitivity Response Data

GAS	CONCENTRATION (PPM)	EQUIVALENT PPM R-114
R11	100	105
R12	100	50
R22	100	35
R113	100	30
R123	100	3
R134a	100	20
R114	100	100
TEST CONDITIONS:	Calibrated 0-1000 PPM R-114 in N ₂ ; Temperature: 25°C	

Table 1-9. Typical Chillgard RT System for R-500 Cross-Sensitivity Response Data

GAS	CONCENTRATION (PPM)	EQUIVALENT PPM R-500
R11	100	8
R22	100	0
R113	100	41
R114	100	60
R123	100	2
R134a	100	7
R502	100	5
R500	100	100
TEST CONDITIONS:	Calibrated 0-1000 PPM R-500 in N ₂ ; Temperature: 25°C	

Table 1-10. Typical Chillgard RT System for R-502 Cross-Sensitivity Response Data

GAS	CONCENTRATION (PPM)	EQUIVALENT PPM R-502
R11	100	25
R22	100	160
R123	100	60
R134a	100	40
R502	100	100

TEST CONDITIONS: Calibrated 0-1000 PPM R-502 in N₂; Temperature: 25°C

Table 1-11. Typical Chillgard RT System for Ammonia* Cross-Sensitivity Response Data

GAS	CONCENTRATION (PPM)	EQUIVALENT PPM AMMONIA
Acetone	1000	45
Methyl Ethyl Ketone	100	25
Methane	2.5%	5
Iso-Propanol	1000	725
Methylene Chloride	1000	12
O-Xylene	100	7
NH ₃	100	100
R11	500	50
R22	550	15
R12	100	65
R134a	100	130
R123	100	20
Propane	0.6%	50
Pentane	0.75%	100
Ammonia	100	100

TEST CONDITIONS: Calibrated 0-1000 PPM Ammonia in N₂; Temperature: 25°C

*This gas has not been evaluated by Underwriters Laboratories, Inc. for the Chillgard RT unit.

Table 1-12. Typical Chillgard RT System for R404a Cross-Sensitivity Response Data

GAS	CONCENTRATION (PPM)	EQUIVALENT PPM R-404a
R11	100	<1
R12	100	3
R22	100	2
R113	100	30
R123	100	40
R134a	100	56
TEST CONDITIONS:	Calibrated 0-1000 PPM R-404a in N ₂ ; Temperature: 25°C	

Chapter 2 Installation and Set-up

Receiving

Upon receipt of the unit, inspect the shipping carton for signs of visible damage. Report any damage to the carrier and note it on the delivery receipt. The unit must be stored in a dry, secure place prior to its installation and use. Store unit in the original shipping carton.

Unpacking the System

To unpack the equipment:

1. Carefully remove the Chillgard RT Monitor from its shipping container(s) in order to prevent damage to sensitive electrical components. If any damage is found, report it to the shipper immediately.



WARNING

Do not install or operate a damaged unit. It may not function properly and may not alert you to any gas conditions.

2. Search through all packing material and containers to avoid inadvertently discarding usable or valuable parts. Report any shortages immediately to MSA.

The contents of the shipping carton are:

- instrument
- manual
- end-of-line filters (may be purchased separately).

Retain the original packing form for re-use in the event the unit must be returned for service.

3. Using a screwdriver, loosen the two latches on the Chillgard RT door (FIGURE 2-1) by turning 1/4 turn counterclockwise.
4. Open the front door.

Initial Inspection

With the front door open, carefully inspect components and assemblies inside the enclosure. If damage or shortage is evident, advise and promptly file the proper claim with the carrier.

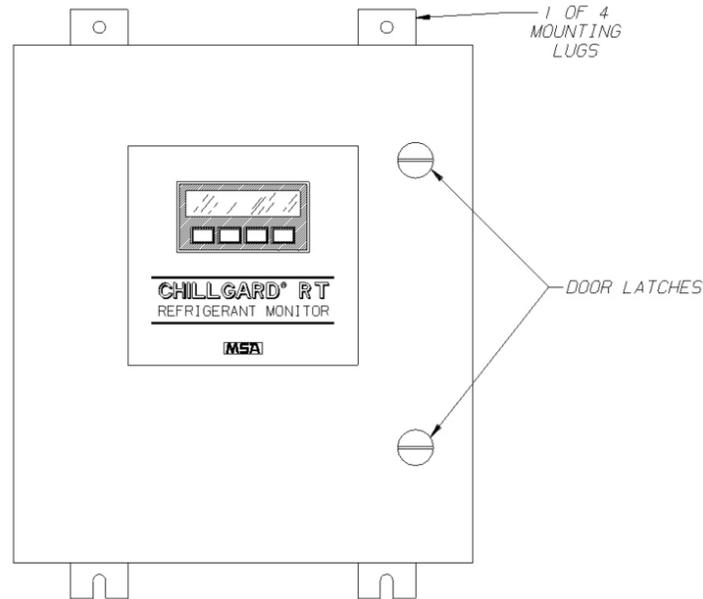

Figure 2-1. Front Door Latches

Location of the Monitor



WARNING

This unit must not be located in areas that may contain a flammable mixture of gas and air; otherwise, an explosion may occur.

The monitor performance is dependent on its location and sensing pick-up location(s). Follow the guidelines listed below before mounting the monitor.

Instrument Location Guidelines

1. Select a location where personnel will see the front panel or the optional beacon before they enter the equipment room or the area where the monitoring point is located.
2. Mount the unit vertically; do not mount the unit to structures subject to vibration and shock, such as piping and piping supports.
3. Do not locate the unit near an excessive heat source or in wet and damp locations.

4. Do not mount unit where it will be exposed to direct solar heating.
5. For proper cooling, allow at least three inches (7.6 cm) clearance around all surfaces except for the mounting surface.
6. Mount the unit so the front panel is easily seen and accessed for service and calibration.

Guidelines for Locating the Sampling Point(s)

Due to the wide variation in equipment room layouts, each situation must be analyzed individually. A sampling point may be remotely located up to 150 feet (46 m) from the monitor (500 feet [152 m] if 0.180" (4.6 mm) I.D. tubing is used) in an area where refrigerant vapors are most likely to leak or accumulate (FIGURE 2-2).

NOTE: The 150 and 500 feet (46 and 152 m) allowances refer to the total sample and exhaust line length for each sample point.

Equipment Configuration

The equipment arrangement in the room can also have an impact on the most effective place to sample. As a general guideline:

- If there is one chiller in the room, sample at the perimeter of unit.
- For two chillers, sample between them.
- With three or more chillers, multiple monitors or a single monitor with a multi-point sampling system should be used. Airflow patterns must always be considered.

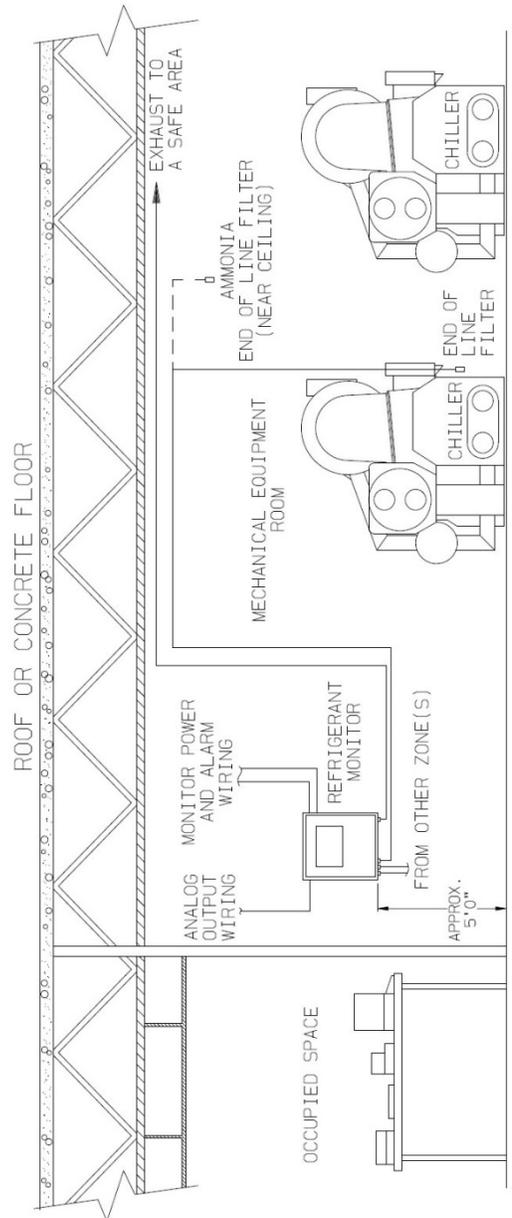

Figure 2-2. Typical Monitor Installation (Monitors without sequencer option have one sampling port; those with sequencer have four or eight ports)

Activity in the Room

The expected activities in the room must also be considered when determining the sensing point. Refrigerants will concentrate near the floor. Typically, sampling 12-18 inches (30.5-45.7 cm) above the floor is sufficient for early warning and to provide adequate protection for someone working close to the floor. If it is expected that an occupant's breathing zone may be less than 12-18 inches (30.5-45.7 cm) off the floor, locate the sampling point accordingly.

NOTE: Select sampling locations which result in the shortest possible line length in order to reduce transport time.

Consider the following guidelines when selecting the location for the sampling point(s).

1. Most refrigerants are heavier than air and sink to the floor or accumulate in low areas.
2. Ammonia gas is lighter than air and tends to rise to the ceiling.
3. Place the end of the sampling line in an area that provides the instrument with a representative sample; ventilation Smoke Tubes (P/N 458480) are useful in determining air flow patterns in ambient sampling areas.
4. Properly exhaust the instrument to a safe area or to outside atmosphere.
5. Ensure the sampling area is free of particulate matter and condensing moisture; ensure sample lines will not draw moisture up into the line.

NOTE: The sample gas must be adequately filtered before entering the instrument. End-of-sample-line filters must be used with the unit. These filters must be installed at the end of all sample lines.

6. Ensure the end of the sampling line is unobstructed to allow the sample to flow freely to the instrument.
7. Keep sample lines as short as possible to reduce transport time.



CAUTION

Ensure that tubing radii are wide enough to prevent kinking or bending. Otherwise, an obstruction may occur, preventing the instrument from sampling the intended area.

8. DO NOT:
- back-pressure the exhaust line or
 - connect it to a vacuum source or
 - install a flow meter in the exhaust line.

ALWAYS :

connect an exhaust line that is vented to a safe area or an outside atmosphere.

Mounting the Unit

The instrument has four mounting lugs (FIGURE 2-1). Securely mount the unit to a wall or support, using appropriate hardware.



WARNING

Do not mount the unit directly to a chiller; the vibration may affect the operation of the monitor, resulting in incorrect readings.

Sample System Installation

1. Remove all caps on the sample inlets and exhaust of the Chillgard RT Monitor (FIGURE 2-3).



WARNING

Failure to remove any caps from the unit gas inlet or exhaust fittings prevents gas sampling and may cause an undetected toxic and hazardous gas build-up and a flow trouble indication.

2. Route the 1/4" (6.4 mm) OD tubing into the areas to be monitored.

NOTE: For Refrigerant Units:

1/4" (6.4 mm) OD rigid copper tubing with compression type fittings is recommended for most refrigerants. Soldered connections on the sample line(s) should be avoided due to the possibility of the monitor being sensitive to the solvents in the soldering flux paste.

For Ammonia Units:

It is recommended that stainless steel tubing and filters be used. Do not use copper or brass for tubing or connection components as they are not compatible with ammonia.

3. After the line(s) are installed and BEFORE they are connected to the monitor:

- a. Clean lines with compressed air or nitrogen to remove any debris.
- b. Perform a leak-check to assure they are free of leaks.
- c. Connect the line(s) to the sample port(s) on the monitor.
- d. Install the end-of-line filters.

NOTE: All unused sample inlet(s) must be plugged or have an end-of-line filter installed to avoid debris entering the unit. To disable these unused lines, refer to the setup screen shown in FIGURE 3-11.

4. Install all tubing ends to the inlet fittings of the unit. Mark the location identity of each individual tubing on the tubing or on the inside of the instrument itself (FIGURE 2-3).
5. Connect the exhaust fitting to tubing which is routed to an area where refrigerant gases may be safely dispersed.



CAUTION

Ensure that each and every sample tubing has an end-of-line filter on it; otherwise, damage to the internal components may result.

Wiring Connections

Opening the Unit

All wiring to the Chillgard RT unit is made via the side entries. Open the unit to provide complete access to all wiring connections.

Ensure that all wiring codes are followed. These codes include, but are not limited to, the National Electrical Code.



CAUTION

Do not open the Chillgard RT unit door unless the equipment is protected from splashing, spraying, or dripping water; otherwise, damage to the internal components may result.

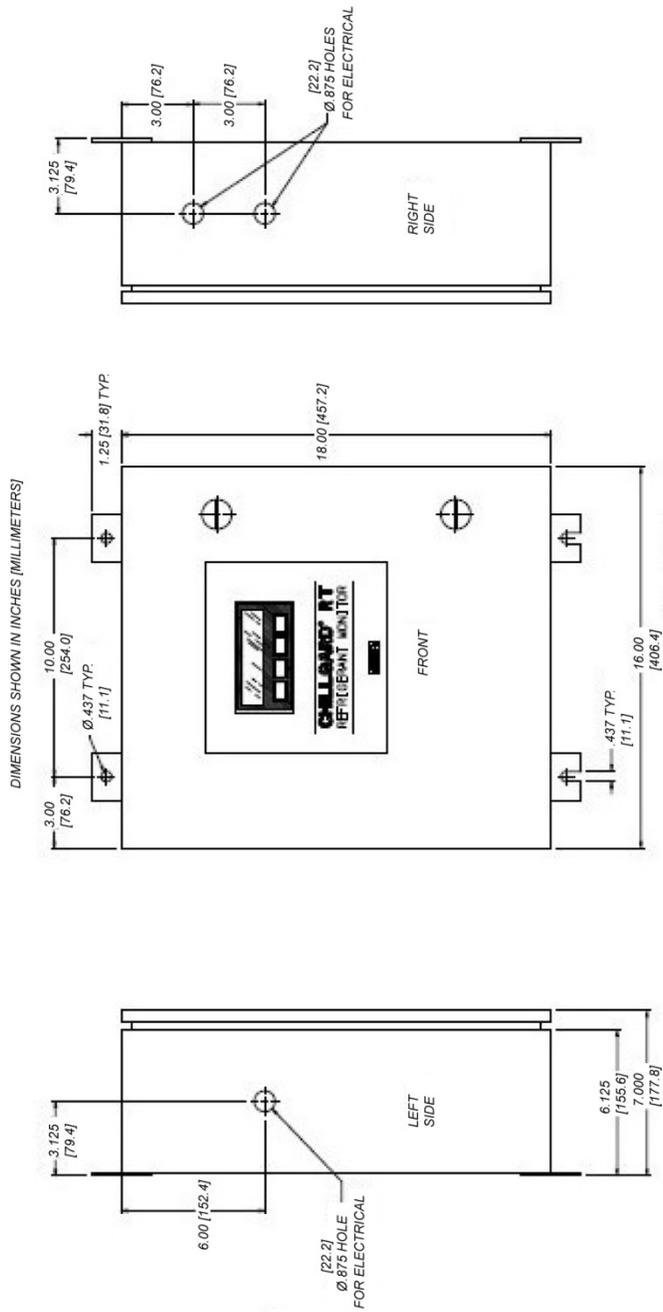

Figure 2-3a. Mounting Dimensions

DIMENSIONS SHOWN IN INCHES [MILLIMETERS]

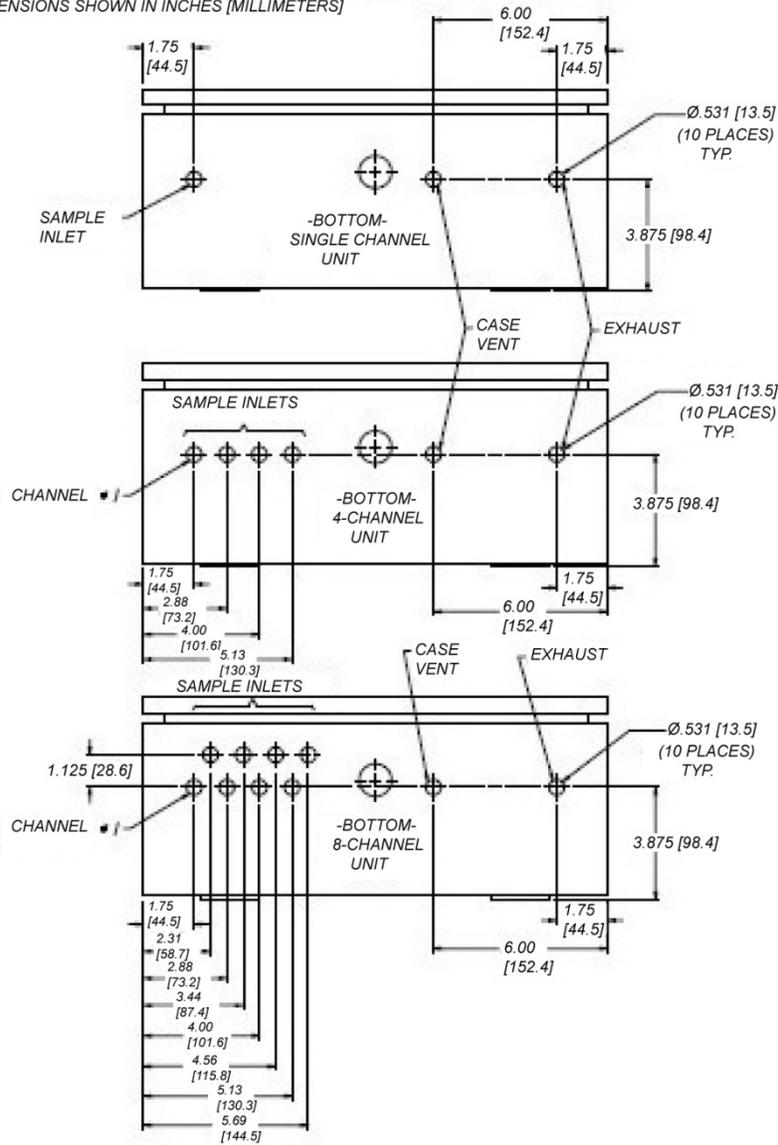

Figure 2-3b. Mounting Dimensions

Unit Power Wiring

A separate, dedicated power source is recommended for the refrigerant monitor to ensure that the unit remains powered when other circuits are shut down for servicing, routine maintenance or shift changes.

The monitor uses a wide range power supply which can accept AC power from 100 to 240 volts, 50 or 60 Hz. The power wiring should enter the unit through one of the openings on the right side of the enclosure. Connections are made to the screw terminals labeled L1, L2, ACN and GND, located in the upper right side of the unit (FIGURE 2-4). The maximum wire size that these connectors can accept is #12 AWG.

The incoming power provided to the monitor determines the configuration of the fuse(s) and wiring to the main power terminal block. FIGURE 2-4 shows the fuse and wire connections for various voltages.



Figure 2-4. Primary Power Wiring

Power Supply Wiring

1. Using a screwdriver, loosen the two latches on the enclosure door (FIGURE 2-1).
2. Open the front door.
3. Determine the power requirements for your Chillgard RT unit, ensuring the power is clean and reliable. (Refer to TABLE 1-1 for current capacity specifications.)



CAUTION

If unsure of your power available, contact your facility engineer or safety officer. If incorrect power is applied, damage may occur to the instrument.

Wiring the Chillgard RT Unit

4. Route power wiring through one of the entries in the side of the unit.

NOTE: Power wiring should be separated from relay wiring.

5. For single fuse 100/120 Volts AC power connection, connect the:
 - power wire to L1
 - neutral wire to ACN
 - ground wire to \perp terminal
6. For double fuse 220/240 Volts AC power connection, connect power wires to L1 and L2 and ground wire to \perp terminal.

Analog Signal Output Wiring (FIGURE 2-5)

The Chillgard RT unit has two available analog outputs. Each analog output is software-selectable between 10% or 100% of full scale:

- 4-20 mA, isolated, current sourcing
- 0-10 VDC

These voltage and current outputs are proportional to the displayed refrigerant concentration. Connections are made to terminal strip J17 located on the lower left side of the main circuit board (FIGURE 2-5). Analog output wiring should enter the unit through the hole provided on the left side of the unit. The terminal portion of the connector can be removed from the circuit board for easier connection. The maximum wire size that these connectors can accept is Listed #12 AWG; the maximum cable length is 500 feet (152 m).

It is suggested that Listed #18 AWG, twisted-pair wire be used. If shielded wire is necessary, ground the shields of all cables at the receiving end of the signal. Do not ground or connect the shields at the Chillgard RT Monitor.

4-20 mA

The 4-20 mA output sources current to a separate return. Connections are made to terminals 2 (I+) and 3 (RTN) on terminal strip J17.

1-10 VDC

The 0-10 VDC output sources voltage to 2 K ohms maximum load. Connections are made to terminals 4 (V+) and 5 (COM) on terminal strip J17.

The voltage output can be programmed to correspond to the channel presently being sampled. The front-panel screen shows:

1V/PT IF OUT = 1-10V

(indicating one volt per point if output equals one to 8 volts).

When enabled, and the unit is monitoring from:

- channel 1:
the voltage output is one volt
- channel 2:
the voltage output changes to two volts.

RS 232 Output

- See Appendix C for wiring information.

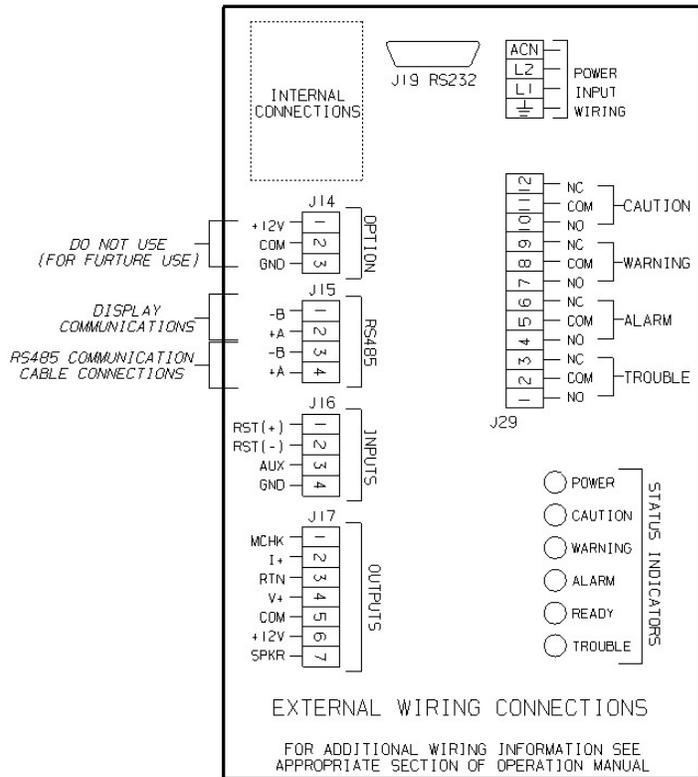

Figure 2-5. Wiring Connections

Ferrite Bead Installation

Some models are shipped with ferrite beads. Follow the instructions below for proper installation.

- The input and output signals must be connected by using twisted, shielded wire pairs.
- The shield or its drain wire (FIGURE 2-6) must be connected to the grounding terminal on the power supply plate.
- Each unit is supplied with Thora-Electronik #16-28-9 or equivalent ferrite (P/N 10017468).
- The shield must also be connected to ground at the receiving equipment.
- The RS 485 communications lines to the relay module must be wired in a similar manner. See Appendix B for more information on the relay module.

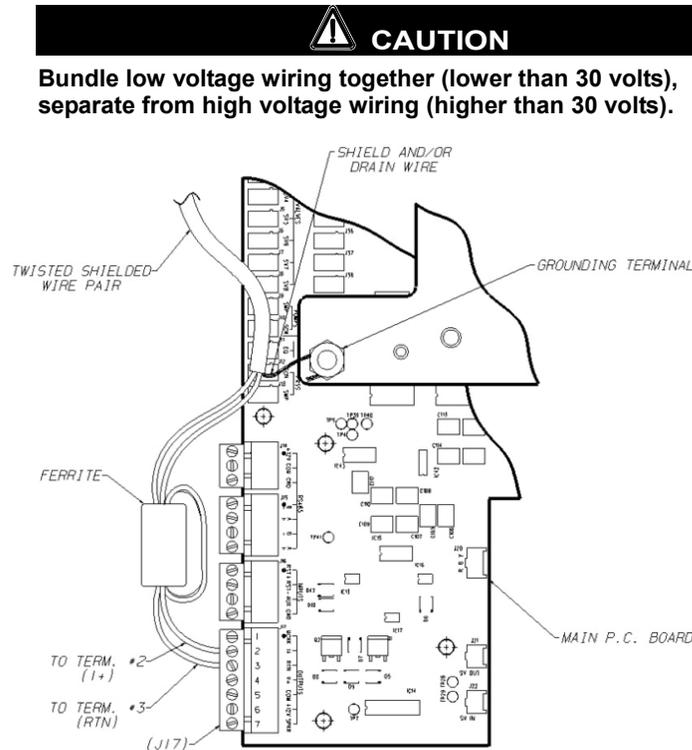

Figure 2-6. Ferrite Bead Installation

Optional Alarm Beacon

Your unit may have an optional alarm kit installed. This kit is made up of a beacon on the top of the unit. It is factory-wired so no additional wiring is necessary; it lights when any alarm indication is given by the instrument. This function parallels the audible alarm output (when the horn sounds, the beacon will light).

Relay Outputs

Alarm Relays

There are three alarm relay outputs:

- Caution (factory-set to trip at 9 ppm)
- Warning (factory-set to trip at 29 ppm)
- Alarm (factory-set to trip at 700 ppm)

Each relay can be set up as latching/non-latching and/or normally-energized/normally de-energized. Contacts are Form C at 240 Volts AC 8 amps resistive. Connect wiring to Terminal Strip J29. User can adjust alarm trip points via the front panel (see Section 3, FIGURE 3-13).

NOTE: Response time equals 90% of a step change and alarm condition within 110 seconds.

Alarm Relay Connections Wiring

Three refrigerant level alarm relay outputs are provided. All alarm relays are Form C, SPDT relays which can be wired to either closed or opened contacts in an alarm condition.

Each relay has contacts for:

- NORMALLY OPEN (NO)
- COMMON (COM)
- NORMALLY CLOSED (NC)

The function of each relay connector terminal is shown on FIGURE 2-5.

Relay wiring should enter the unit through one of the openings on the right side of the unit. Connections are made at the internal terminal strip labeled J29, located on the right side of the circuit board (FIGURE 2-5). The terminal portion of the connector can be unplugged from the circuit board for easier wire connections.

NOTE: The maximum wire size that these connectors can accept is #12 AWG.

Trouble Relay

There is one relay (the Trouble relay) within the unit that indicates that a trouble or start-up condition exists. This relay is configured from the factory and operates differently than the alarm relays. It operates in a normally-energized mode.

This relay is energized when the instrument is:

- normally operating,
- in the calibration mode, or
- in the setup condition.

The relay is de-energized when:

- a fault is detected,
- the unit is in the start-up state, or
- the main power is lost.

This means that power is no longer provided to the relay coil. It is not possible to change the configuration of the Trouble relay.

The relay connector function or identification:

- NORMALLY OPEN (NO),
- COMMON (COM),
- NORMALLY CLOSED (NC)

as marked in FIGURE 2-5 refers to the relay contacts as if the relay is de-energized or in the trouble condition. A relay contact is provided between the Normally Closed (NC) and Common (COM) position. This contact will be made in the event that main power to the unit is lost or any other trouble condition exists.

Trouble Relay Connection Wiring

The Trouble relay wiring should enter the unit through one of the entries on the right side of the unit. Connections are made at the internal terminal strip labeled J29, positions 1, 2 and 3 (located on the right side of the circuit board - FIGURE 2-5). The terminal portion of the connector can be unplugged from the circuit board for easier wire connections. The maximum wire size that these connectors can accept is #12 AWG.

Remote Reset

The audible alarm and latched refrigerant level alarms can be remotely

reset through a switch that has a momentary contact opening (normally closed set of contacts). Connections are made to terminal strip J16, terminals 1 and 2 with the wiring entering the enclosure through the hole on the left side of the instrument. The switch must have signal-level contacts, typically gold plated. The maximum distance from the reset switch to the monitor, using 18 AWG wire, is 250 feet (76 m). The maximum wire size that these connectors can accept is #12 AWG.

Audible Alarm Output

An output is provided to drive the piezo-electric horn on the bottom of the unit (FIGURE 1-5). This output is available for customer use, provided that the beacon is not installed.

Auxiliary Input - Use UL Listed Devices

A 4-20 mA analog input can be made to the monitor from another device such as another refrigerant monitor or an oxygen monitor. The input wiring should be brought into the enclosure through the hole on the left side of the instrument and connected to terminals 3 (AUX) and 4 (GND) on terminal strip J16. It is recommended that Listed #18 AWG, twisted pair wire be used; maximum wire length is 250 feet (76 m). The maximum wire size that these connectors can accept is Listed #12 AWG. Shielded wire is necessary. Ground the shields of all cables at the transmitting end of the signal. Do not ground or connect the shield at the Chillgard RT Refrigerant Monitor.



CAUTION

All field wiring must be done in accordance with national and local electrical codes.

Initial Calibration



WARNING

Calibrate after installation; otherwise, false or erroneous readings can result.

The initial calibration is the same as the routine calibration. Refer to Section 4 for this procedure.

Multipoint Sequencer Operation

In the sequencer setup screens, unneeded points can be de-activated by using the RIGHT ARROW key and selecting the point to be de-activated.

- When the change key is pressed, the number in the display goes blank.
- After pressing OK, the display shows a dark diamond to indicate which points are de-activated (see FIGURE 3-11).

In the sequencer setup screens, the monitor can be locked on a single point by pressing CHANGE before the RIGHT ARROW key.

- After pressing the RIGHT ARROW key and OK, only the selected point is indicated.
- After an hour (if no buttons are pushed), the monitor returns to normal sequencer operation (see FIGURE 3-12).

When calibrating:

- the gas inlet point can be selected.
- an inactive point can be selected.

After leaving calibration:

- the monitor returns to the previous sequencer setup (FIGURE 3-4).

Chillgard RT operation with a sequencer has a normal dwell time of 30 seconds per sample line, or four measurement cycles.

To improve monitor performance in noisy environments and eliminate false alarms due to high noise, a user-selectable parameter "threshold" was established.

- The factory value for this threshold is 30%.
 - The threshold value is used with the Caution Alarm setpoint to determine when additional readings must be made on the current sample line to confirm actual concentration at the sample point.
 - The allowable adjustment range for the threshold value is 30% to 70%.
- If this value is greater or equal to the product of the threshold and the Caution Alarm value, the monitor dwells for an additional 60 seconds or eight more measurement cycles.
- Raising the threshold above 30% prevents false alarms but also requires greater gas concentrations to cause the Caution Alarm to trip (see FIGURE 2-7).

Chapter 3

Start-up and Initial Adjustments

Before applying power to the Chillgard RT Refrigerant Monitor, follow the Appendix A check list. This will help ensure that the instrument is properly configured for operation.

All instrument operation is performed via the front panel which consists of four keys and a two-line by 20-character vacuum fluorescent display. There is no reason to open the unit for set-up, calibration or diagnostic testing of the instrument. The most commonly used, self-explanatory screens appear on the following pages. Simply follow the on-screen menus. The step-by step approach guides you through each operation.

- The Display Screen Flow Overview (FIGURE 3-1a and 3-1b) shows a general system function flow. See the following FIGURES for specific Display Screen details:
 - Start-up and Normal Operation Screens (FIGURE 3-2a and 3-2b)
 - Calibration Screens (FIGURES 3-4 through 3-6)
 - Information Screens (FIGURES 3-7 through 3-10 and FIGURES 3-23 and 3-24)
 - Set-up Screens (FIGURES 3-3 and 3-11 through 3-22).

CHILLGARD RT DISPLAY SCREEN OVERVIEW

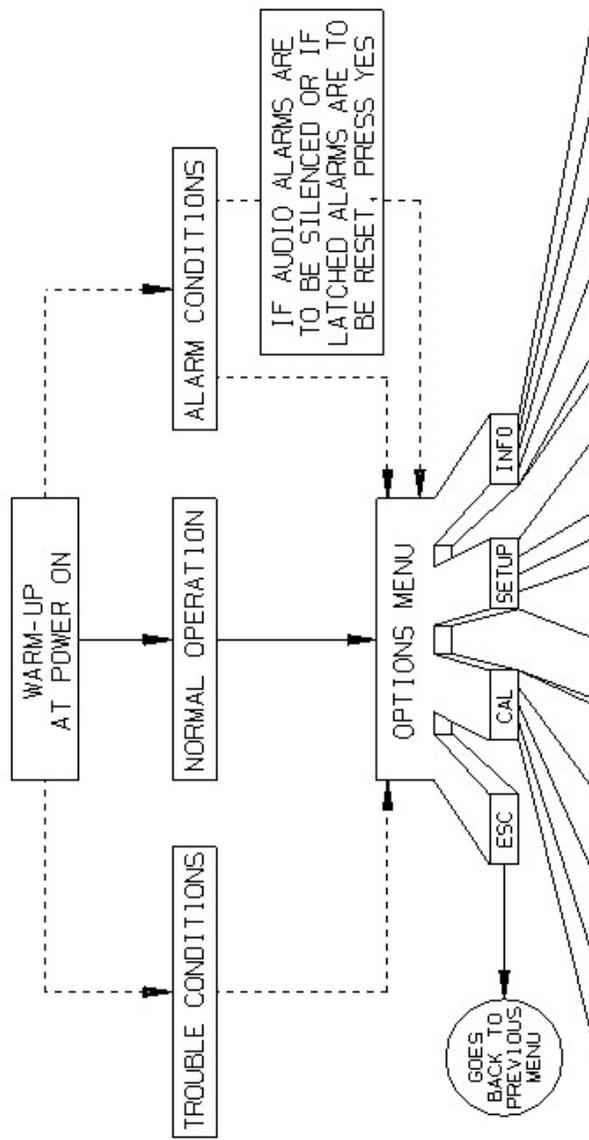

Figure 3-1a. Display Screen Overview

At Power-ON...

TARGET GAS ANY KEY FOR MENU <input type="checkbox"/> <input type="checkbox"/> <input type="checkbox"/> <input type="checkbox"/>	WARMUP THIS IS THE FIRST SCREEN THAT WILL APPEAR AFTER A BRIEF HARDWARE AND MEMORY TEST WHEN POWER IS APPLIED. "ANY KEY" TAKES THE USER TO THE "OPTIONS MENU"
--	--

Trouble Condition

TARGET GAS ANY KEY FOR MENU <input type="checkbox"/> <input type="checkbox"/> <input type="checkbox"/> <input type="checkbox"/>	TROUBLE THIS SCREEN WOULD APPEAR IF A "TROUBLE" CONDITION OCCURRED. "ANY KEY" TAKES THE USER TO THE "OPTIONS MENU" SCREEN WILL FLASH IN THIS CONDITION.
--	--

Only if Audio Alarm is ON...

RESET ALARMS? ESC NO YES NEXT <input type="checkbox"/> <input type="checkbox"/> <input type="checkbox"/> <input type="checkbox"/>	FROM THE ABOVE SCREENS THIS WILL APPEAR BEFORE THE "OPTIONS MENU" IF THE AUDIO ALARM IS ON OR ALARMS ARE LATCHED. "ESC" TO ABOVE SCREENS OR OTHER KEYS TAKE THE USER TO THE "OPTIONS MENU"
---	--

Sequencer Warmup Screen

PT:12345678: WARMUP ANY KEY TARGET GAS <input type="checkbox"/> <input type="checkbox"/> <input type="checkbox"/> <input type="checkbox"/>	THIS IS HOW A SEQUENCER SCREEN WILL APPEAR DURING WARMUP (4-POINT SEQUENCER ALSO AVAILABLE). NON-ACTIVE POINTS ARE BLANKED OUT. "ANY KEY" TAKES THE USER TO THE "OPTIONS MENU"
---	--

Sequencer Alarm Screen

PT:12345678: 50 PPM AL: CWAANC-- TARGET GAS <input type="checkbox"/> <input type="checkbox"/> <input type="checkbox"/> <input type="checkbox"/>	CAUTION, WARNING AND ALARM STATUS APPEAR BELOW EACH POINT. "ANY KEY" TAKES THE USER TO THE "OPTIONS MENU" "A" IS FOR AUXILIARY INPUT IF INSTALLED.
--	--

Figure 3-2a. Start-up and Normal Operation Screens

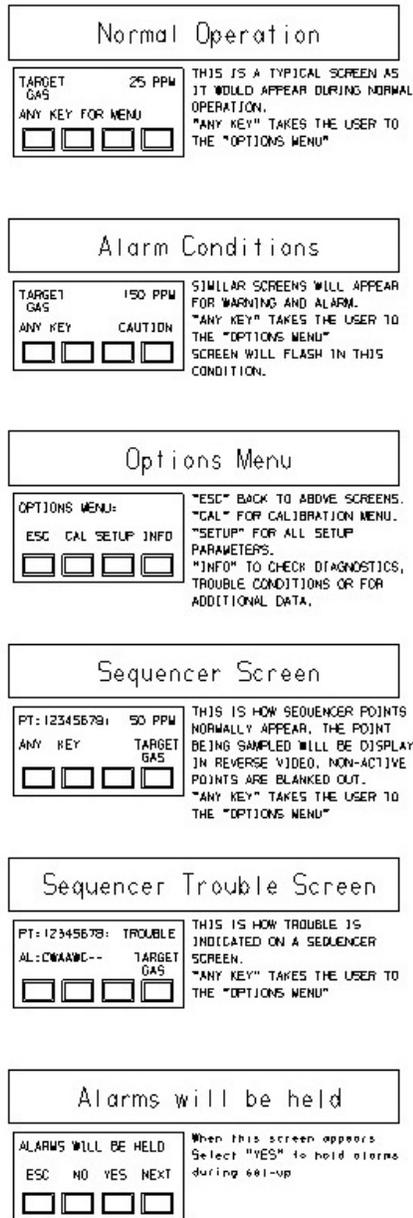

Figure 3-2b. Start-up and Normal Operation Screens Continued

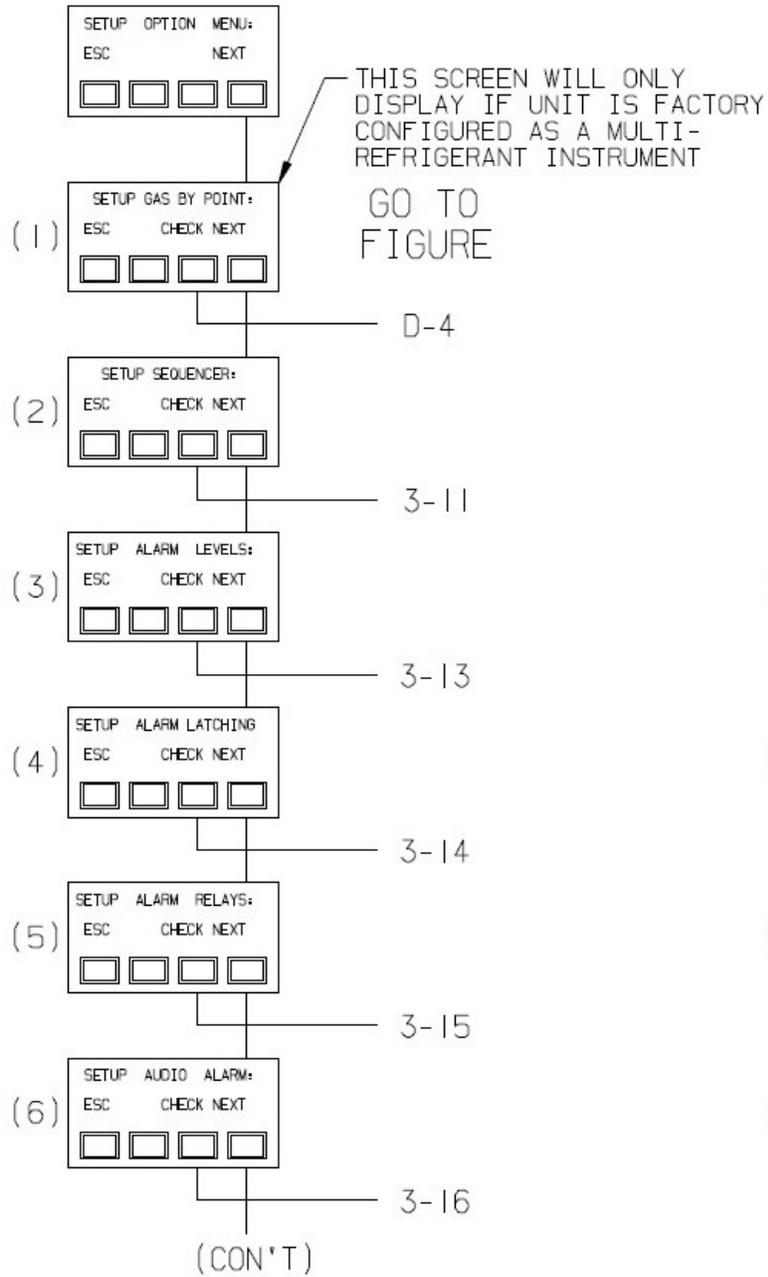

Figure 3-3a. Setup Screens

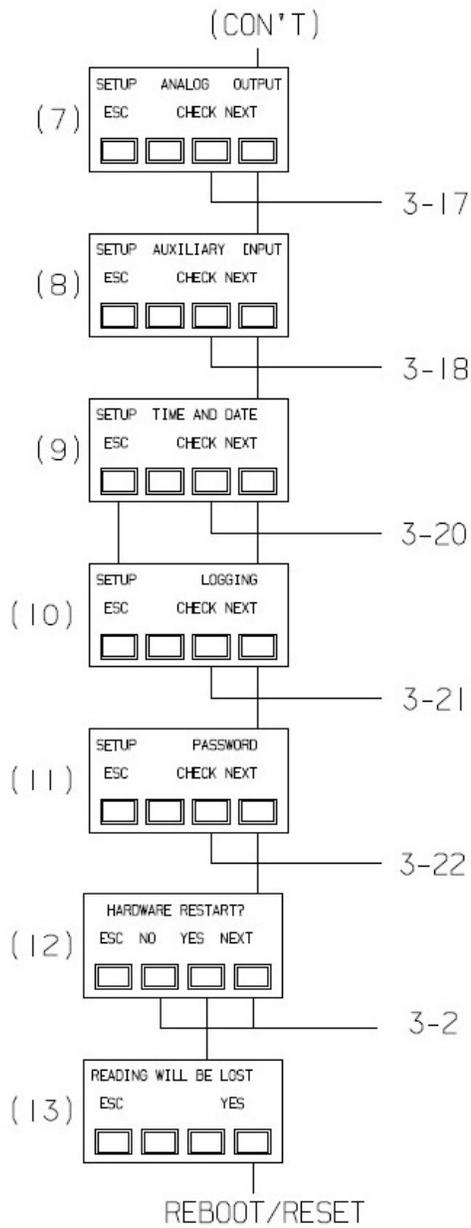

Figure 3-3b. Setup Screens Continued

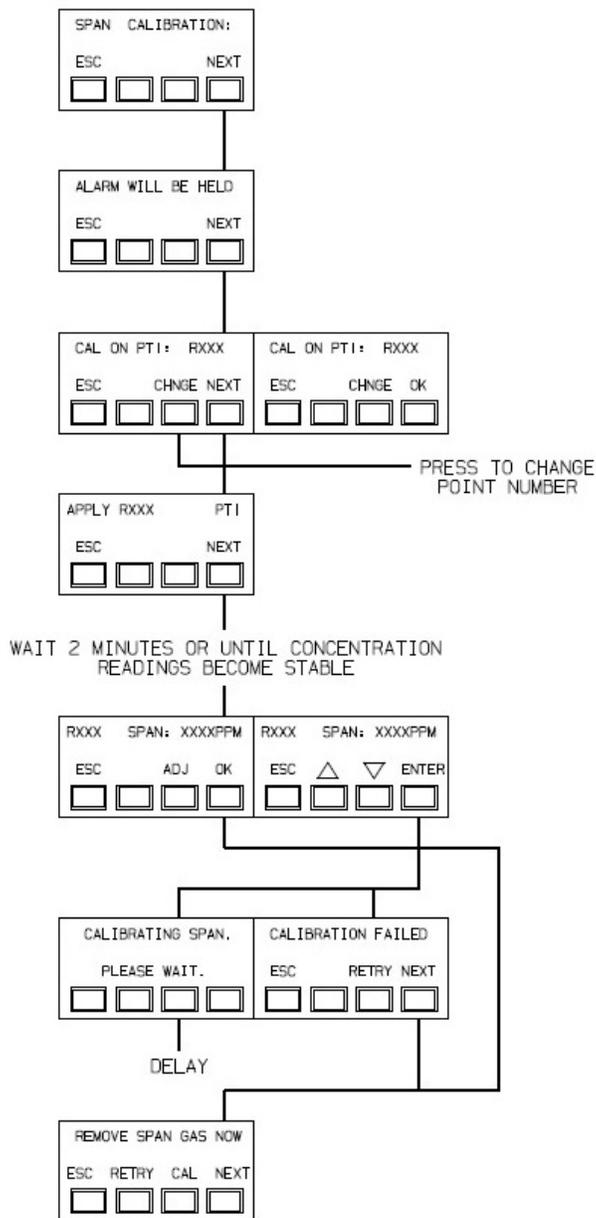

Figure 3-4. Span Calibration

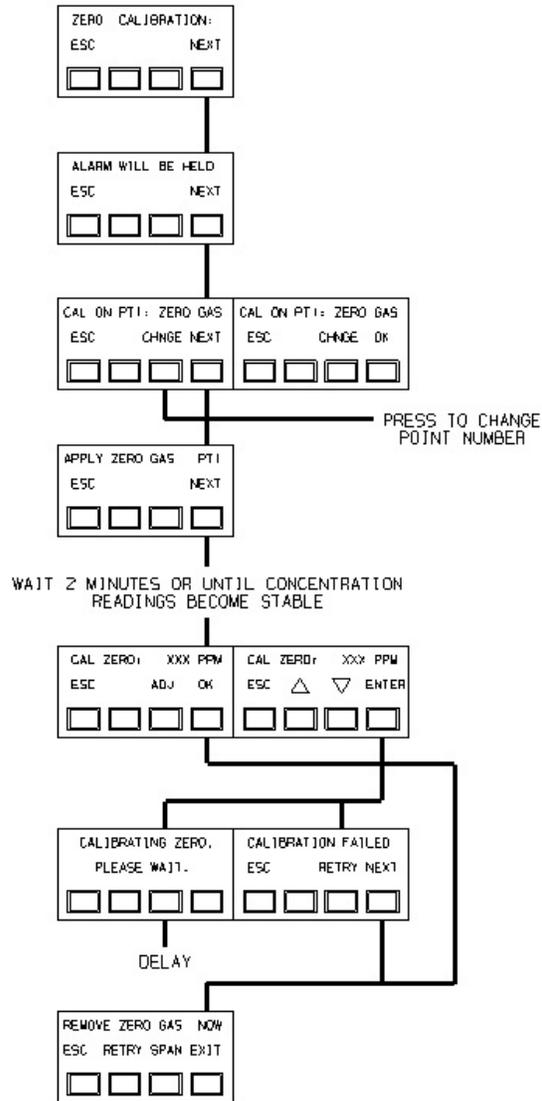

Figure 3-5. Zero Calibration

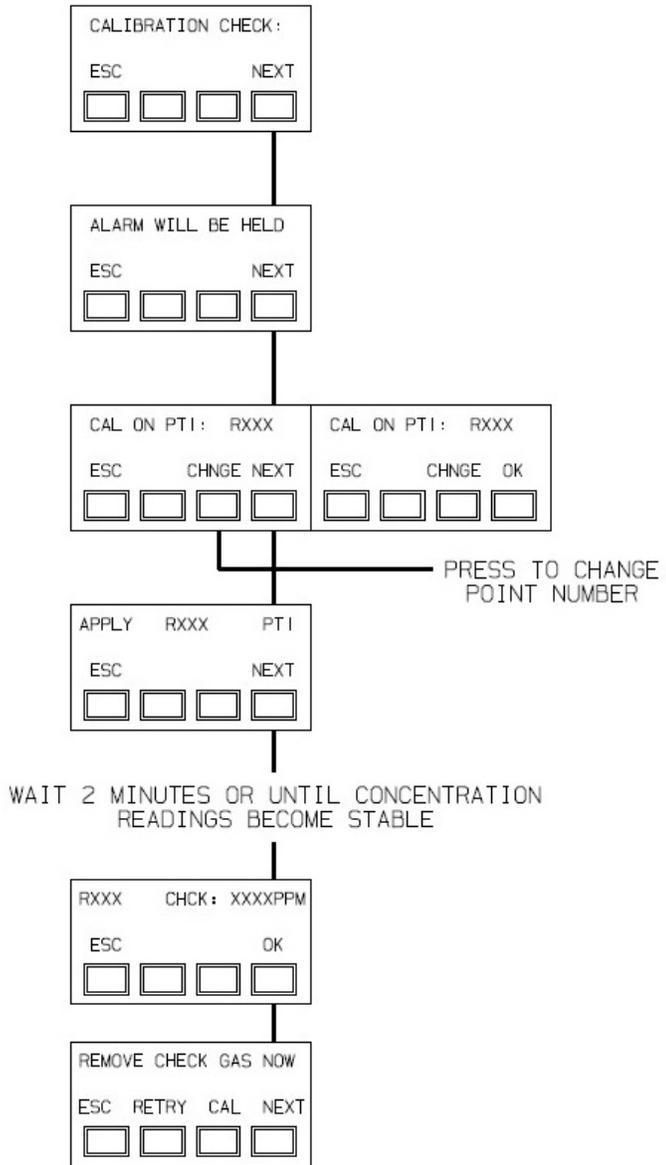

Figure 3-6. Check Calibration

TROUBLE DIAGNOSTICS:
ESC NEXT
□ □ □ □

UNDERRANGE: PASS
ESC NEXT
□ □ □ □

CALIBRATION: PASS
ESC NEXT
□ □ □ □

BYPASS FLOW: PASS
ESC NEXT
□ □ □ □

START BYPS FLOW: PASS
ESC NEXT
□ □ □ □

SENSOR FLOW: PASS
ESC NEXT
□ □ □ □

START SNSR FLOW: PASS
ESC NEXT
□ □ □ □

CASE TEMP SENR: PASS
ESC NEXT
□ □ □ □

GO TO
FIGURE 3-8

Figure 3-7. Diagnostic Screens

CASE TEMP RANGE: PASS
ESC NEXT
□ □ □ □

THERMOSTAT SNBR: PASS
ESC NEXT
□ □ □ □

SENSOR TEMP RND: PASS
ESC NEXT
□ □ □ □

HUMIDITY SENSOR: PASS
ESC NEXT
□ □ □ □

INFRARED SOURCE: PASS
ESC NEXT
□ □ □ □

PHOTO SYNCHRO: PASS
ESC NEXT
□ □ □ □

PA IR SENSOR: PASS
ESC NEXT
□ □ □ □

MEMORY PROTECT: PASS
ESC NEXT
□ □ □ □

GO TO
FIGURE 3-9

Figure 3-8. Diagnostic Screens

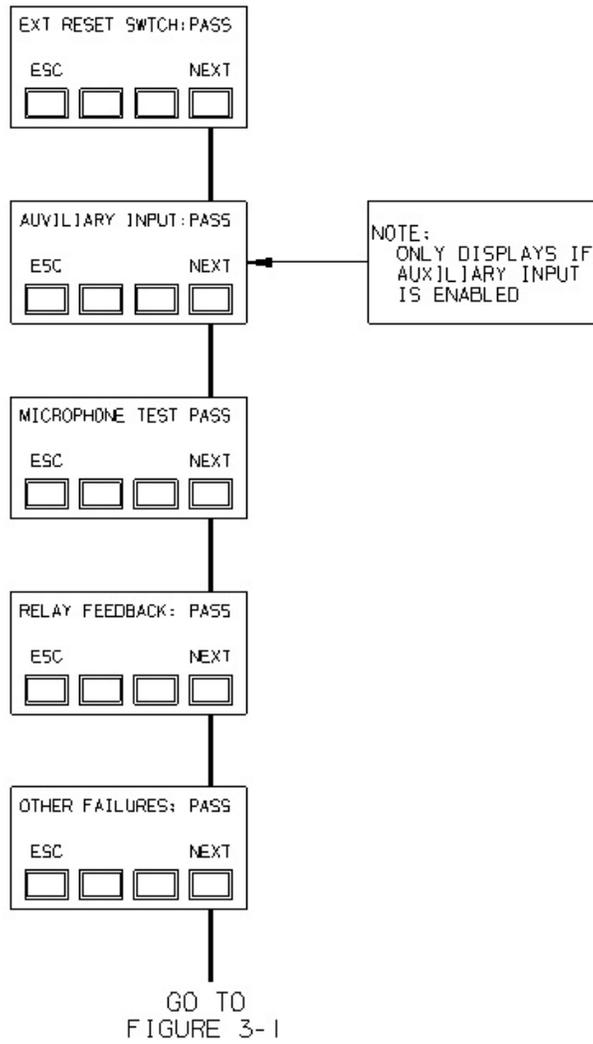

Figure 3-9. Diagnostic Screens

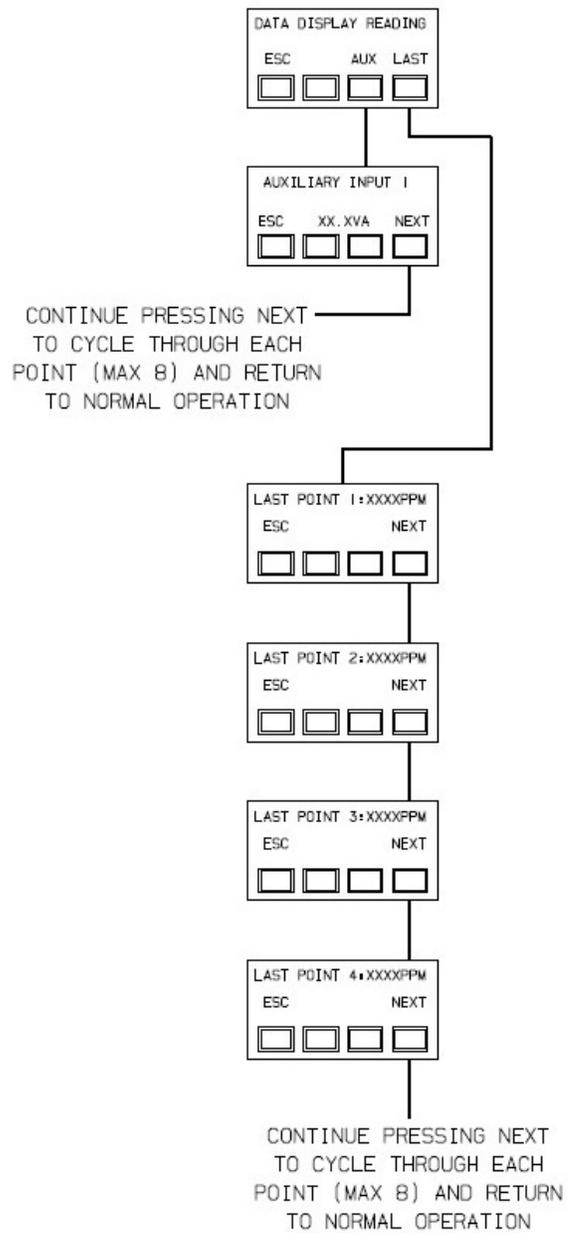

Figure 3-10. Data Screens

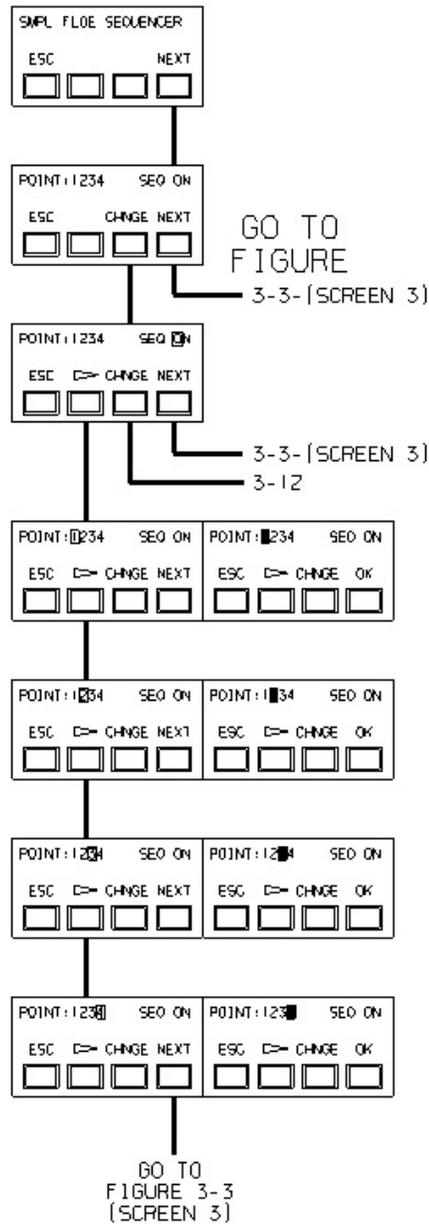

Figure 3-11. Sequencer Set-up Screen

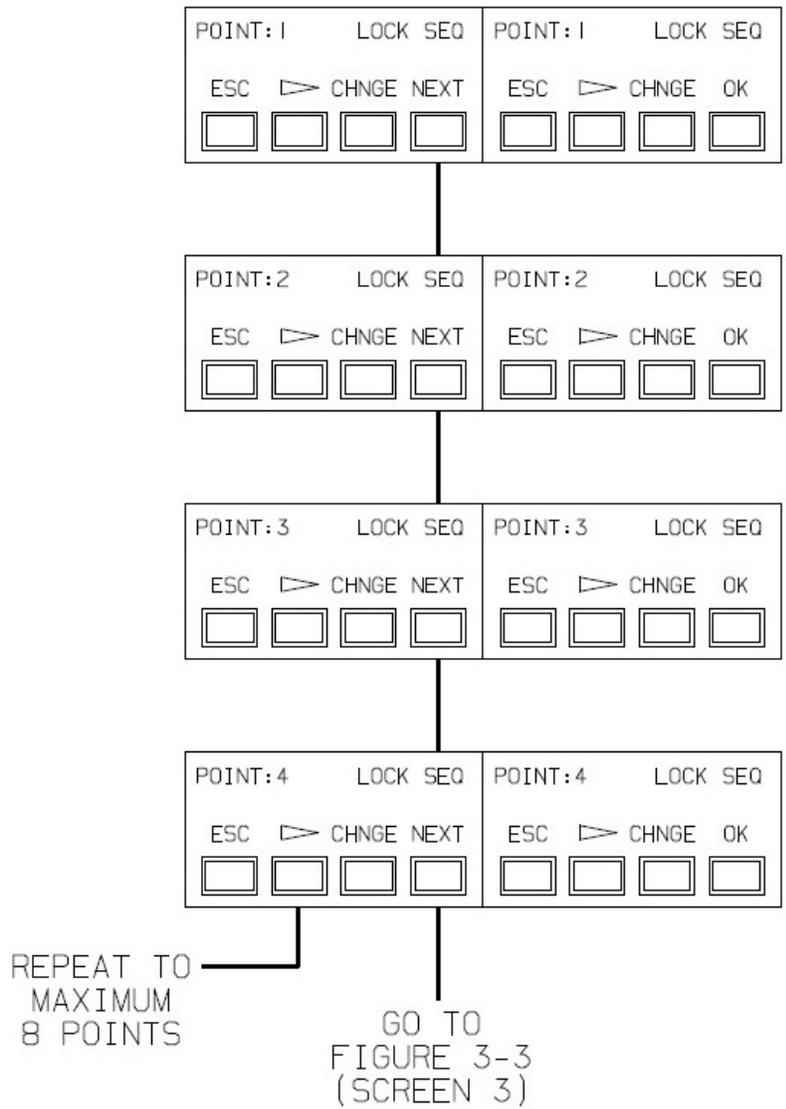

Figure 3-12. Sequencer Set-up Screen

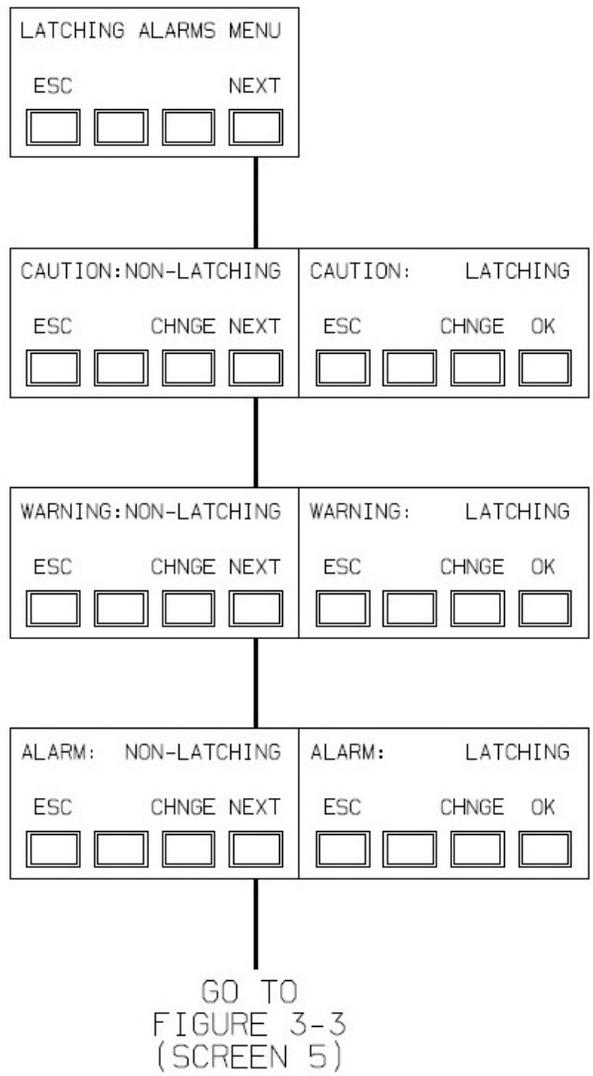

Figure 3-14. Alarm Latching Screen

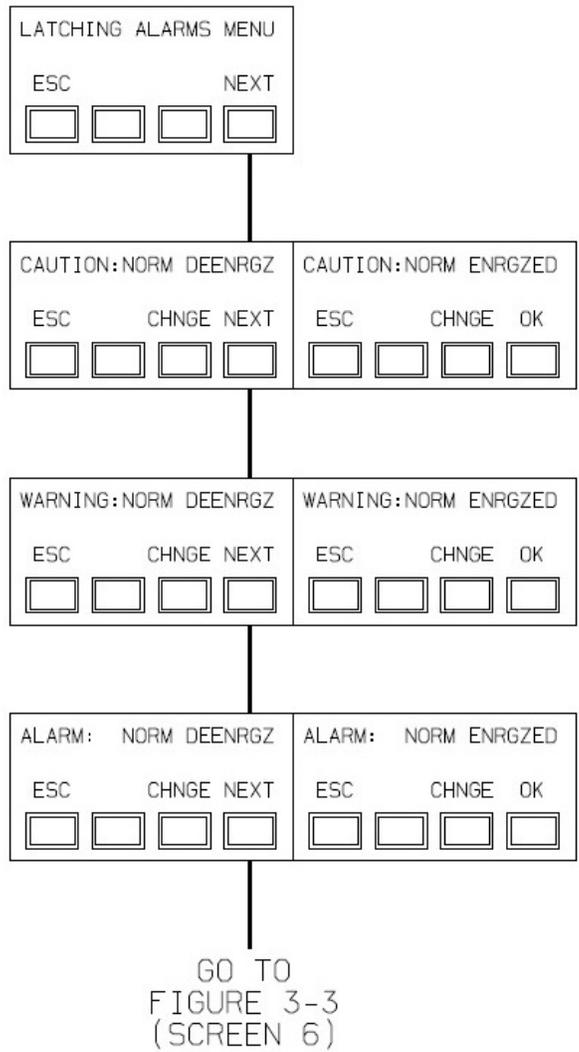

Figure 3-15. Alarm Latching Screen

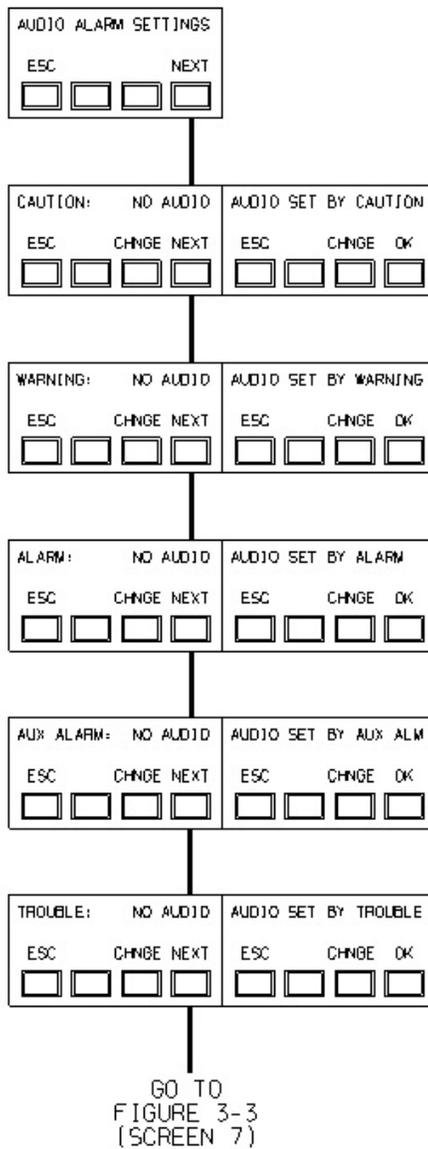

Figure 3-16. Audio Alarm Screen

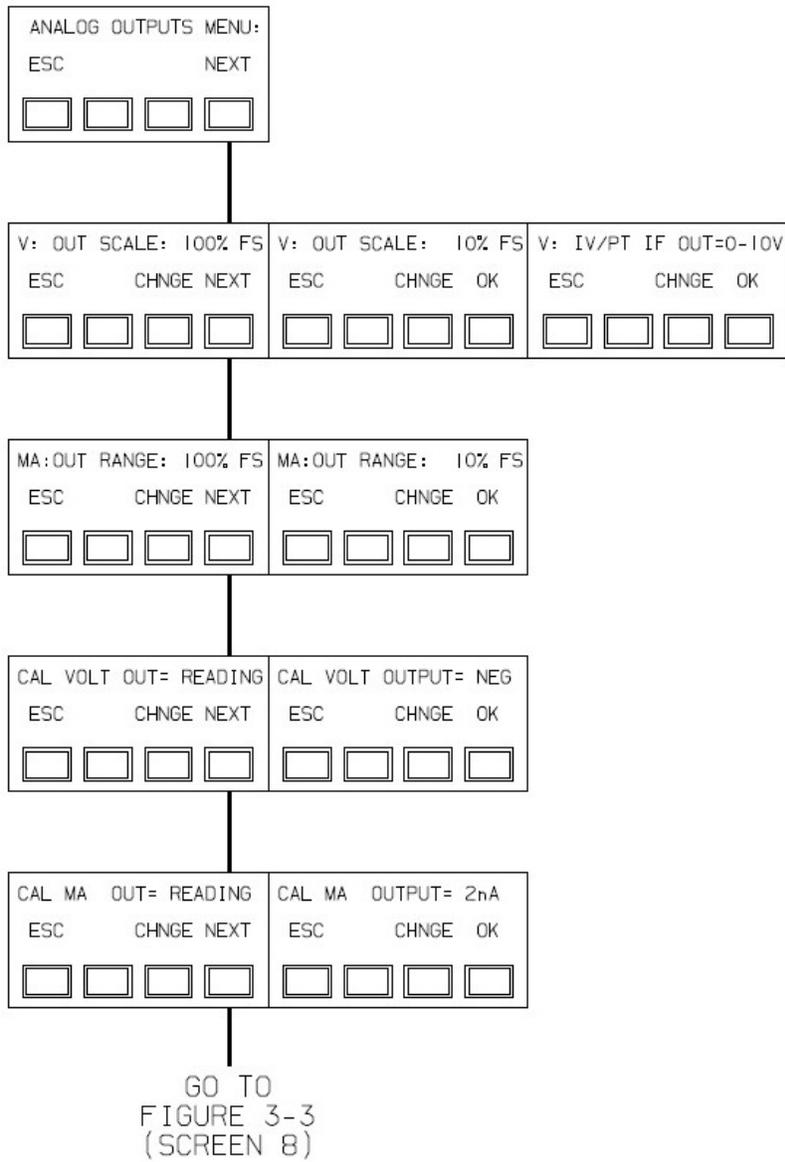

Figure 3-17. Analog Output Screen

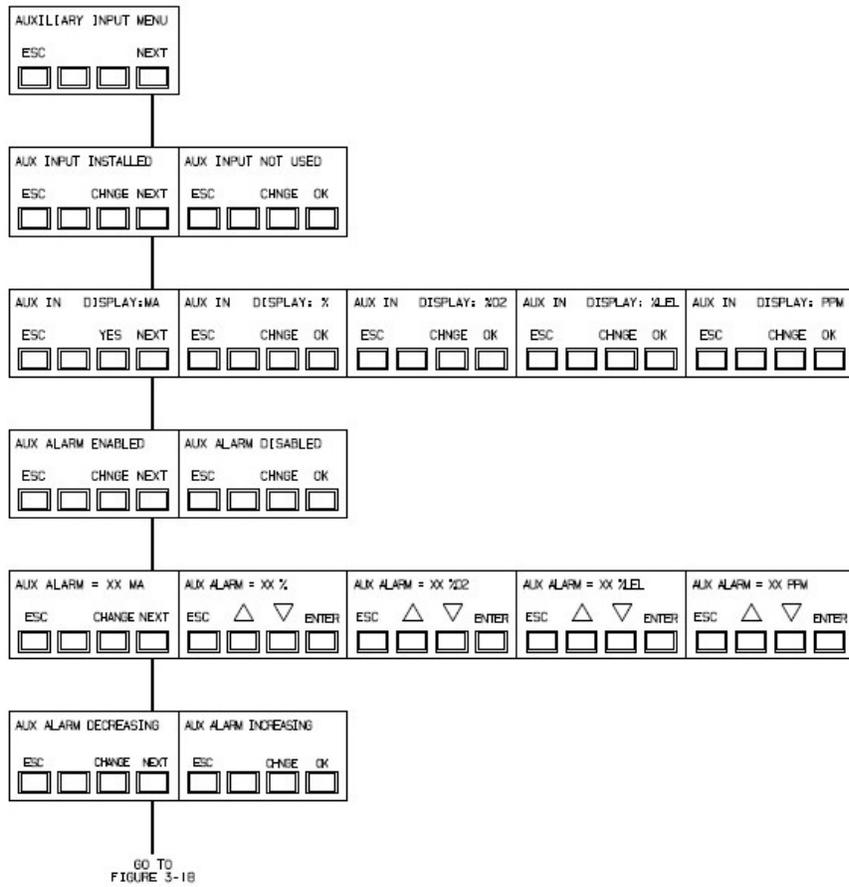
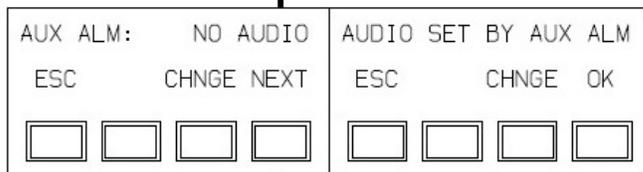
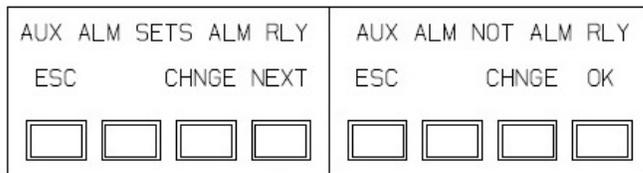

Figure 3-18. Aux Alarm Screen



GO TO
FIGURE 3-3
(SCREEN 9)

Figure 3-19. Auxiliary Alarm Screen

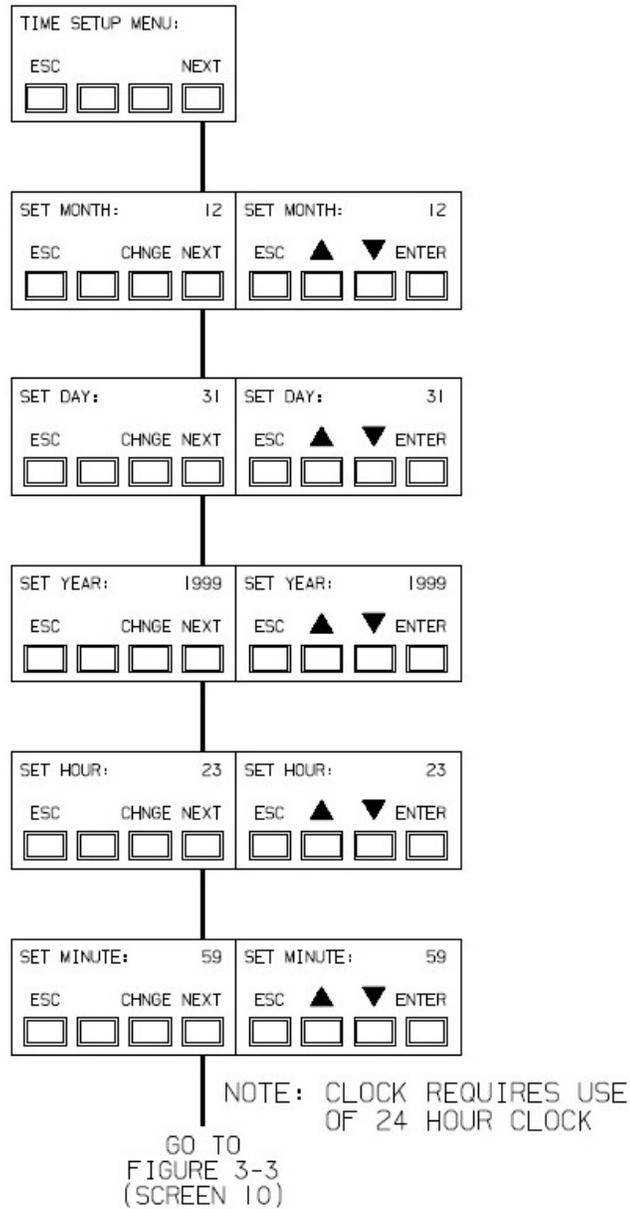

Figure 3-20. Setup Time

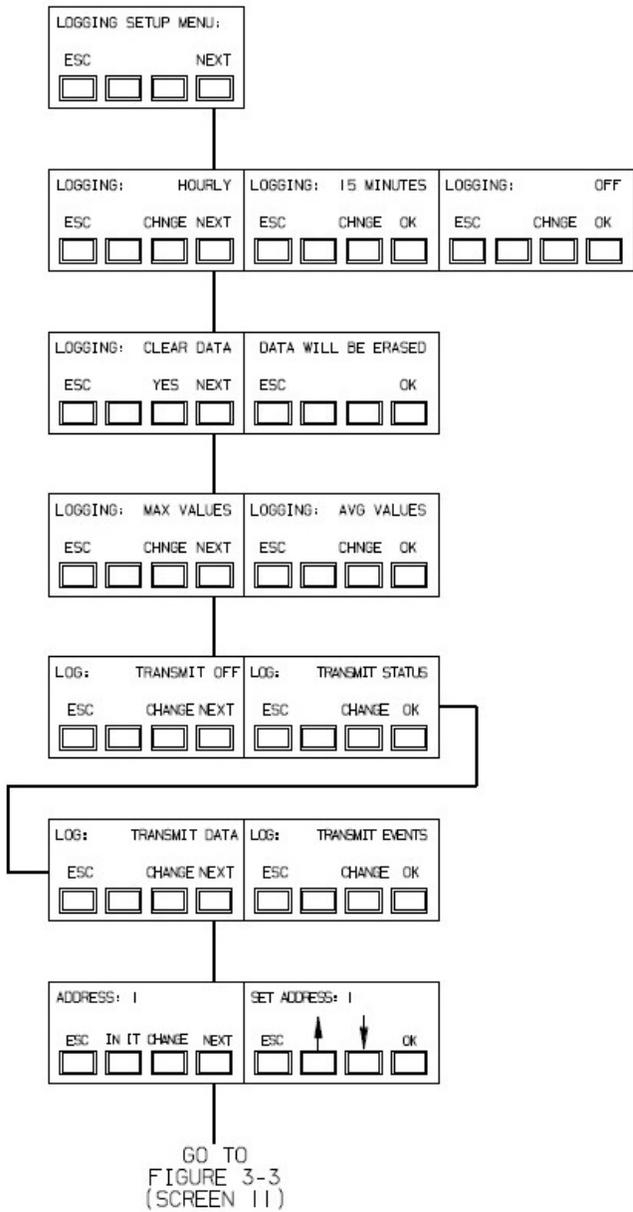

Figure 3-21. Setup Log

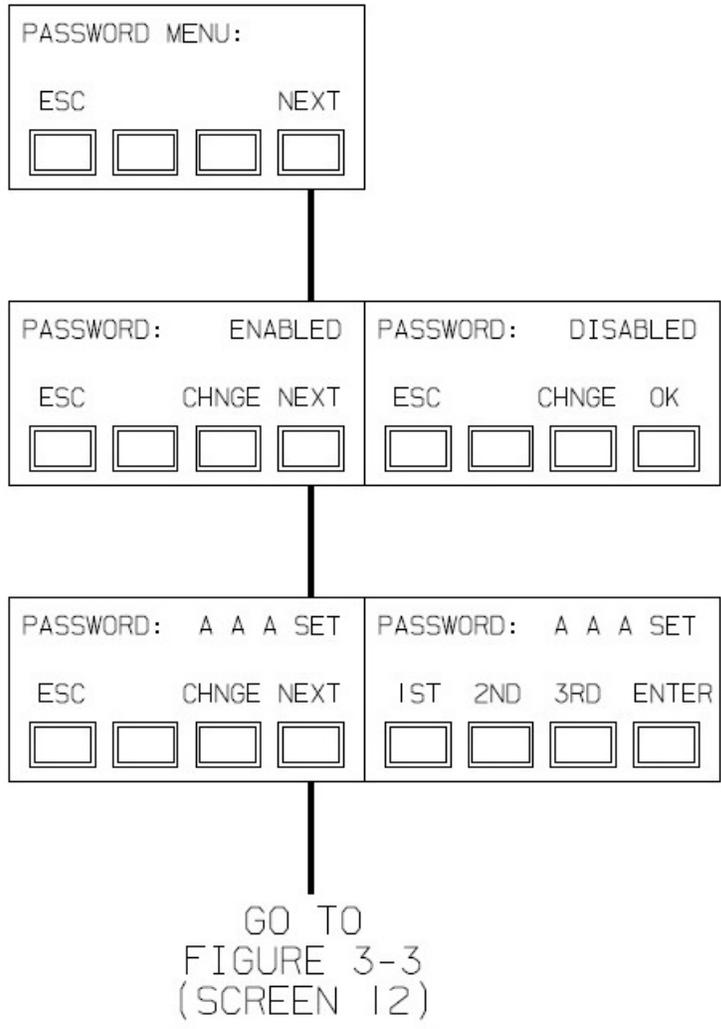

Figure 3-22. Setup Password

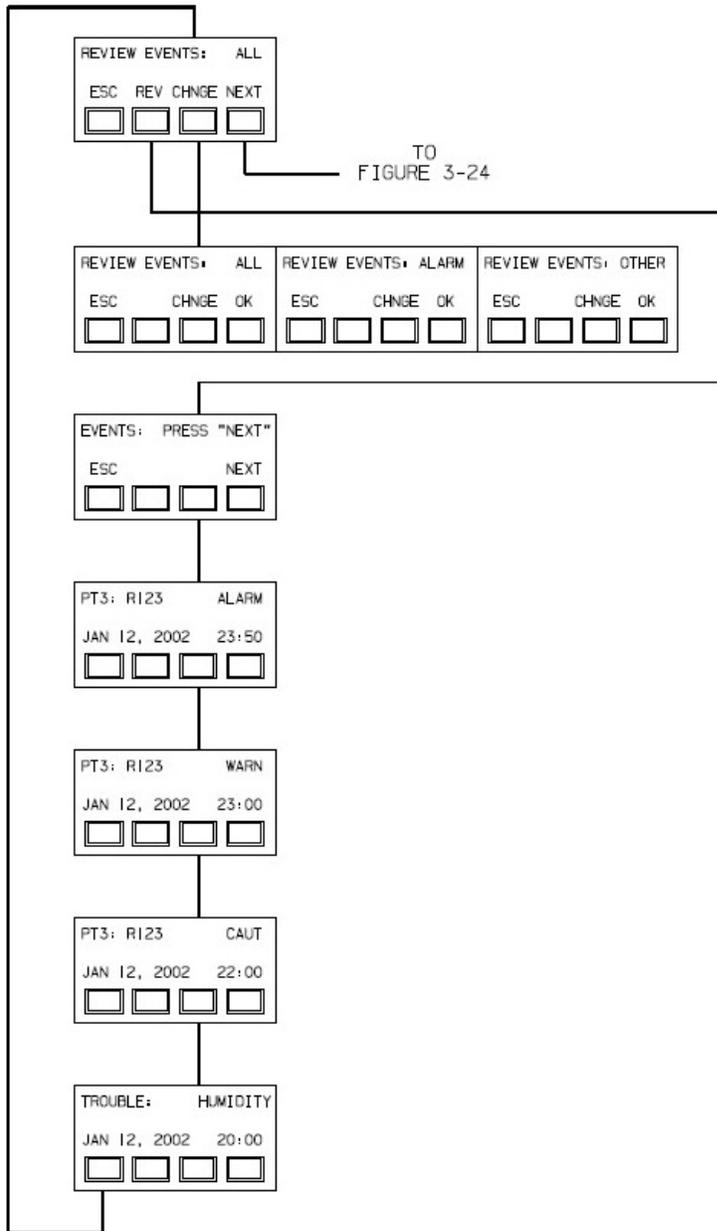

Figure 3-23. Review Log

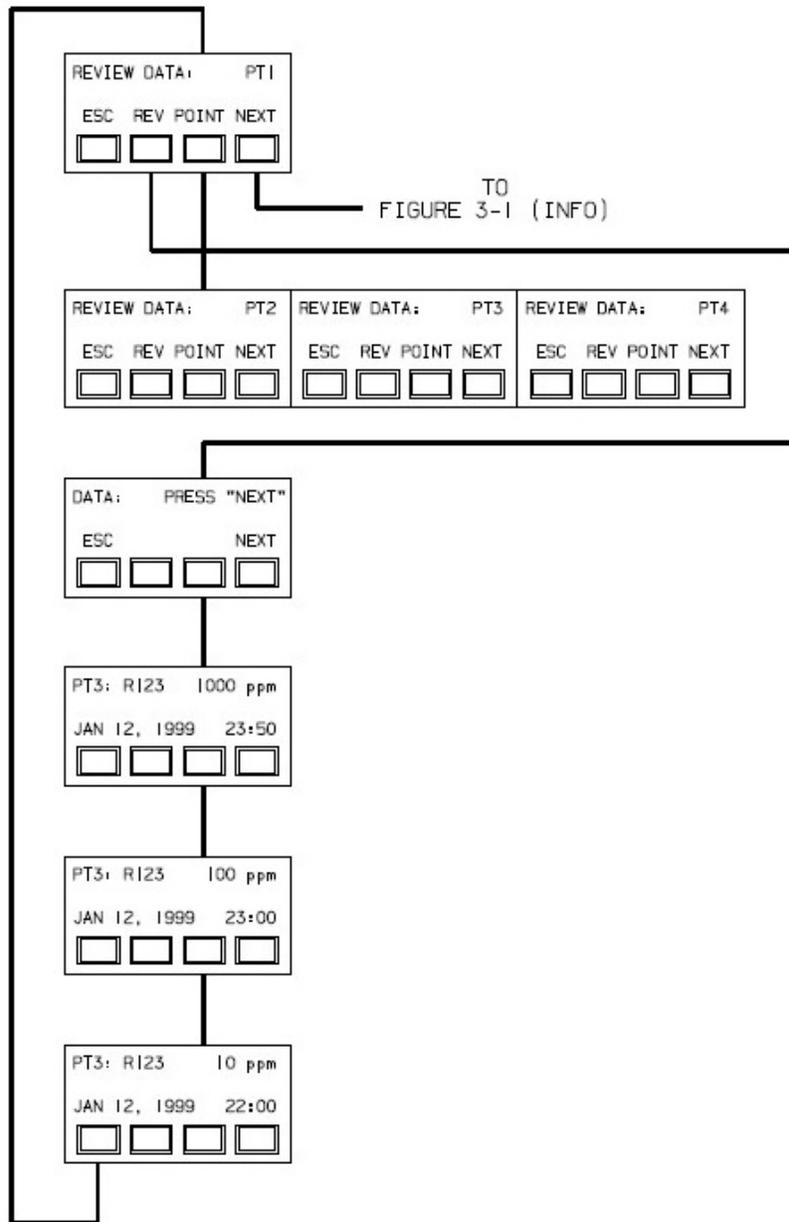

Figure 3-24. Review Data

Chapter 4

Calibration

Introduction

As with any type of gas monitor, the only true check of its performance is to apply gas directly to the sensor. The frequency of the calibration gas test depends on the operating time and exposures of the sensors. New monitors should be calibrated more often until the calibration records prove stability. The calibration frequency can then be reduced to the schedule set by the safety officer or plant manager.

Perform the calibration procedure regularly and maintain a log of calibration adjustments. Calibration frequency may increase for a variety of reasons. If calibration cannot be performed at any step, STOP; consult MSA at 1-800-MSA-INST.

Calibration Equipment

Equipment needed:

- Calibration Kit (MSA ATO #50; FIGURE 4-1)
- A SPAN gas cylinder
- Optional ZERO gas cylinder.
 - A ZERO gas cylinder may not be needed.
 - **For ammonia units, zero gas cylinder must be used.**

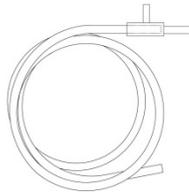

Item 1 - Tube and Tee Assembly
(P/Ns 603806 and 636866)

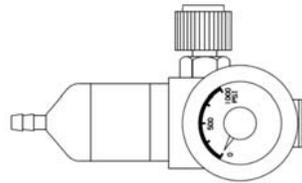

Item 2 - 1.5 LPM Flow Controller
(P/N 478358)



Item 3 - Connector Assembly
(P/N 711533)

NOTE: When used with older models of Chillgard Monitors, the nut end of the connector must be cut off to fit into the Chillgard sample inlet.

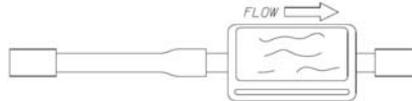

Item 4 - Span Gas Scrubber
(P/N 803874)

NOTE: Replace protective caps after use.

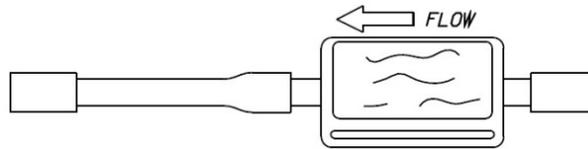

Item 5 - Zero Gas Scrubber (P/N 803873)

NOTE: Replace protective caps after use.

Figure 4-1. Kit Components

The Calibration Kit contains a ZERO gas scrubber which can be used in place of a ZERO gas cylinder if the ambient air around the Chillgard RT contains little or no refrigerant.



CAUTION

The zero gas scrubber must be replaced periodically. The frequency of replacement depends on the concentration of the ambient refrigerant vapors.

The SPAN or ZERO cylinders (if needed) may be included with the Calibration Kit; cylinders shown in TABLE 4-1 are available from MSA:

Table 4-1. RP Calibration Gases

DESCRIPTION	CONCENTRATION	PART NO.
R-11 in Nitrogen	100 PPM	803499
R-12 in Nitrogen	100 PPM	804866
R-123 in Nitrogen	100 PPM	803498
R-134A in Nitrogen	100 PPM	803500
R-22 in Nitrogen	100 PPM	804868
R-113 in Nitrogen	100 PPM	804870
Pentane in Nitrogen substitute for Ammonia	0.75%	804532
Zero Air for CHILLGARD RT only	100%	10028042
R-11 in Nitrogen	30 PPM	812785
R-12 in Nitrogen	30 PPM	812823
R-113 in Nitrogen	30 PPM	813368
R-114 in Nitrogen	30 PPM	813369
R-123 in Nitrogen	30 PPM	812784
R-134a in Nitrogen	30 PPM	812787
R-22 in Nitrogen	30 PPM	812786
R-500 in Nitrogen	30 PPM	813370
R-502 in Nitrogen	30 PPM	813371
R-404a (use R-134a in Nitrogen as substitute)	100 PPM	803500

Become familiar with the Calibration Kit components (FIGURE 4-1).

Chillgard RT identification

You must identify your unit as a single-point monitor or a multi-point monitor for proper calibration gas connection. Refer to FIGURE 4-2 to help identify your unit.

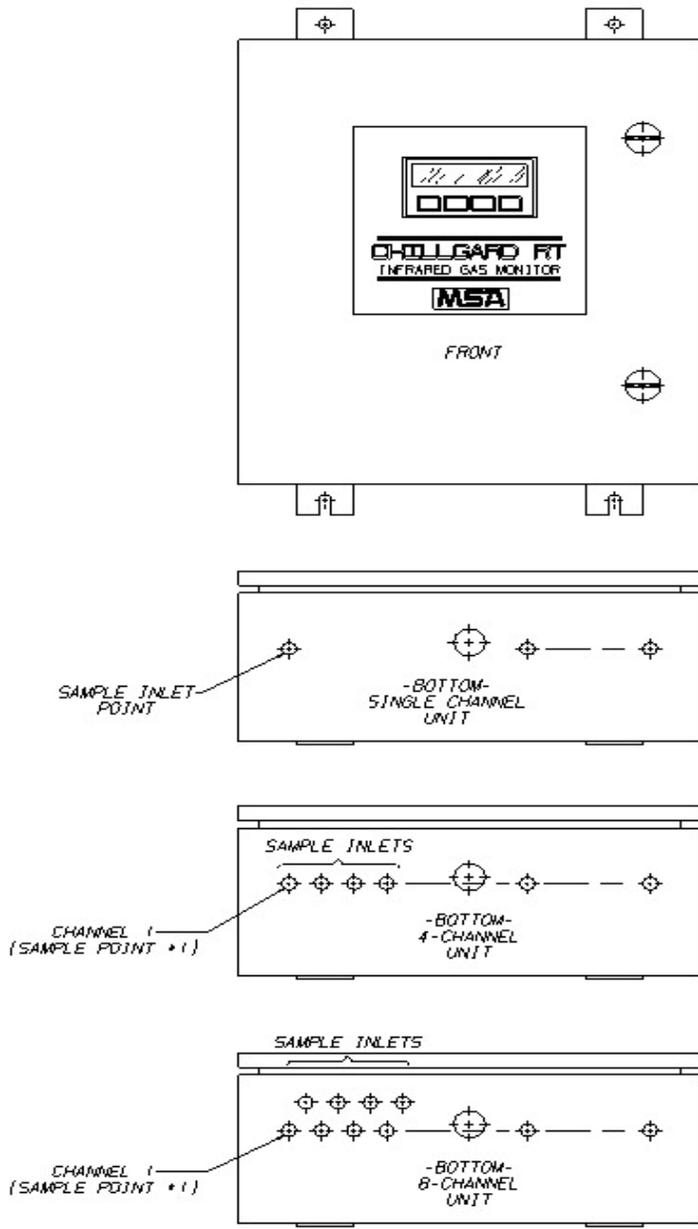

Figure 4-2. Chillgard RT Models

Calibration Procedures

Before calibrating the Chillgard Monitor, leak-check the sample line(s) connected to the monitor:

1. Temporarily block the sample inlet at the end-of-line filter(s) and verify that the monitor gives a trouble alarm.
 - If the monitor is a Multipoint Sequencer, the trouble alarm will not activate until the blocked sampling point is selected by the Sequencer.
2. After checking for leaks, remove the sampling line for the Chillgard inlet.
 - On Multipoint Monitors, use sample inlet Point 1.
3. Attach the Calibration Kit connector assembly to the inlet.
4. Before applying gases, familiarize yourself with the calibration screens by stepping the monitor through the whole sequence. Press the keys in the following order:

Table 4-2. Calibration Sequence Screens

#	PRESS	RESULT
1	ANY KEY	BRINGS UP MENU
2	CAL	BRINGS UP CAL MENU
3	USER	ALLOWS ADJUSTMENTS
4	ZERO	ALLOWS ZERO CALIBRATION
5	NEXT	PROMPT: ALARMS ARE NOW OFF
6	NEXT	PROMPT: SAMPLE POINT 1 TO BE USED
7	NEXT	PROMPT: APPLY ZERO GAS
8	NEXT	PROMPT: ADJUST OR OK READING
9	OK	PROMPT: REMOVE ZERO GAS
10	SPAN	PROMPT: GO INTO SPAN CALIBRATION
11	NEXT	PROMPT: ALARMS ARE OFF NOW
12	NEXT	PROMPT: SAMPLE POINT 1 TO BE USED
13	NEXT	PROMPT: APPLY SPAN GAS
14	NEXT	PROMPT: ADJUST OR OK READING
15	OK	PROMPT: REMOVE SPAN GAS
16	NEXT	PROMPT: ALARMS ARE NOW ACTIVE
17	NEXT	RETURNS TO NORMAL OPERATION

- When this sequence is done with zero and span gases, adjust the zero and span readings (if necessary) in TABLE 4-2 steps #9 and #15, respectively.

- If adjustments are needed, press ADJ to access the UP, DOWN and ENTER keys; enter the zeroing and spanning adjustments.
4. **Zeroing the Monitor:**
When zero gas is required, attach a zero gas scrubber or zero gas cylinder to the connector as shown in FIGURE 4-3.
- NOTE: Use only the zero gas cylinder on monitors calibrated for ammonia.
5. **Spanning the Monitor:**
When span gas is required, a span gas cylinder must be attached to the connector as shown in FIGURE 4-4.

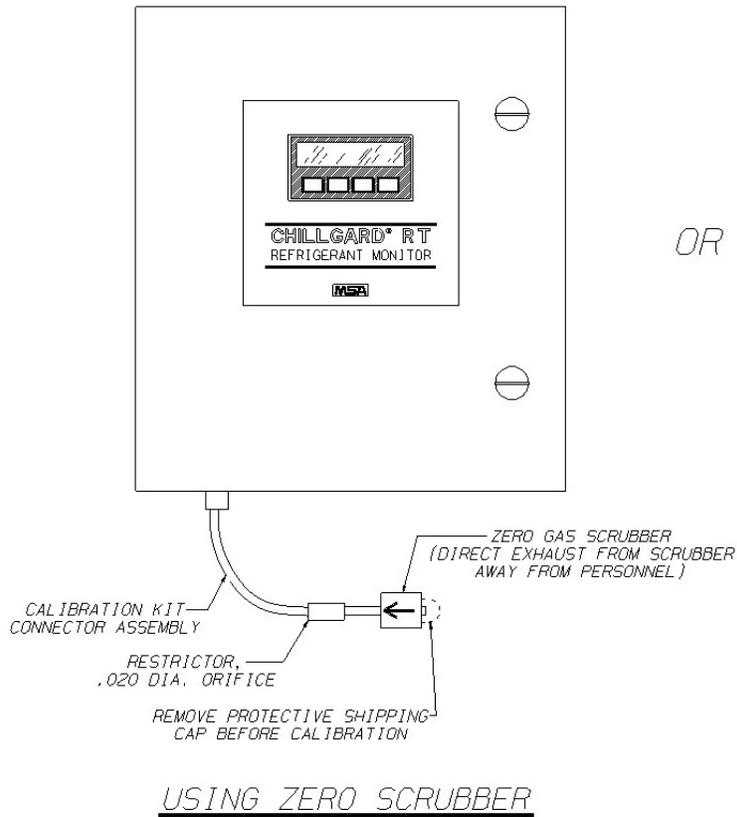

Figure 4-3a. Zero Calibration

NOTE: The span gas must be appropriate for monitor calibration. For many applications, a span gas cylinder of the refrigerant of interest is available from MSA. If a span gas cylinder of the specific refrigerant is not available, MSA has determined an appropriate synthetic span gas. See TABLE 4-1 for calibration cylinders available from MSA. If a synthetic span gas is used (such as pentane for ammonia monitors or use R134a for 404a calibration), refer to the calibration label on the inside of the monitor door (FIGURE 4-5).

Set the unit to the value given on the "synthetic span" label shown in FIGURE 4-5.

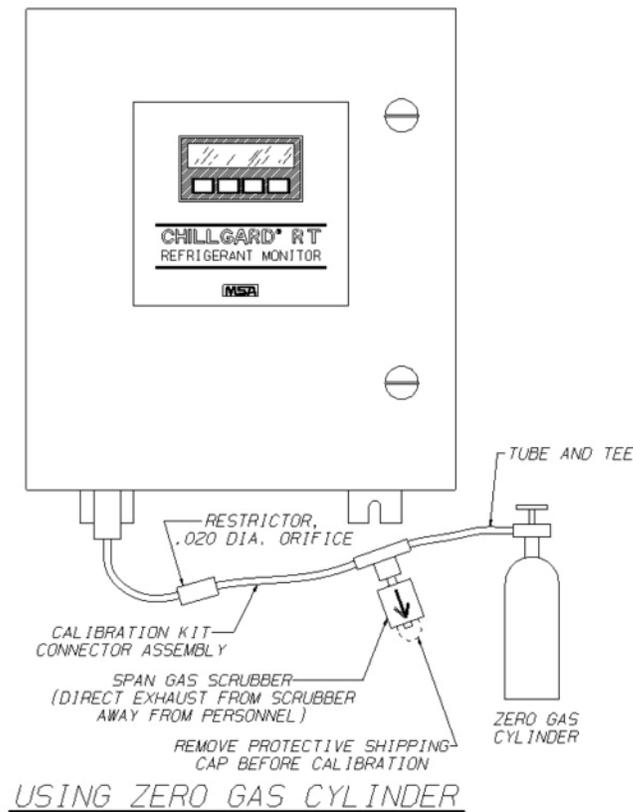

Figure 4-3b. Zero Calibration Continued

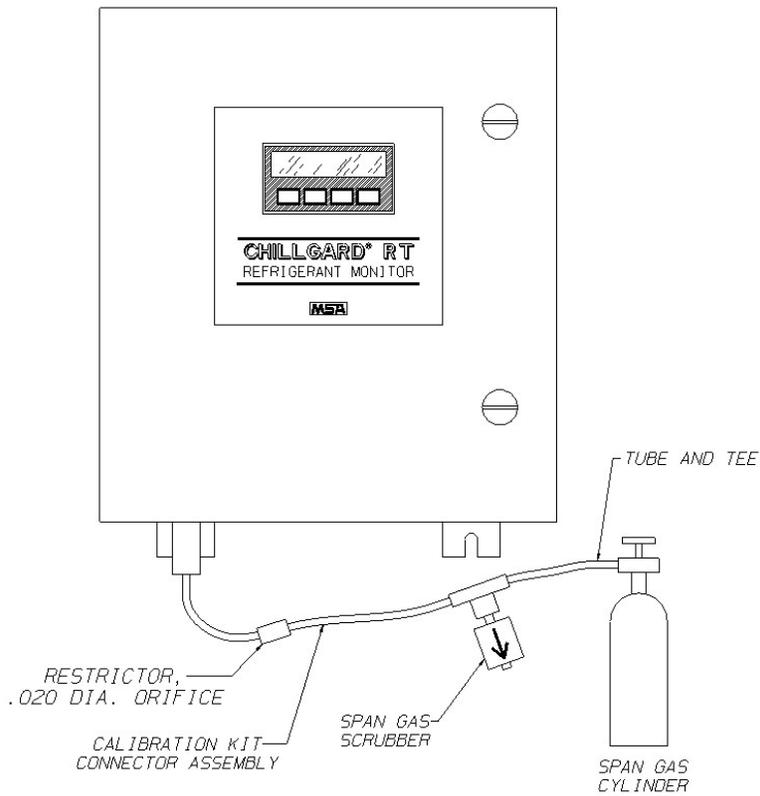

Figure 4-4. SPAN Calibration

Factory Performance Test/Verification
Calibration Gas Mixture: _____
Synthetic Span: _____
MSA Cylinder P/N: _____
Cylinder Reading: _____
Certified Sensitivity Range: _____
Certified Accuracy: <u>See Installation Literature Specifications</u>
Test Date: _____
Test Reference Number: <u>See Unit Serial Number</u>
Instruction Manual Revision Number: _____
Inspector: _____

Figure 4-5. Ammonia or R-404a Unit Calibration

6. Perform the TABLE 4-2 sequence.
 - a. Apply zero gas when requested.
 - Allow enough time for a stable reading.
 - b. Accept (OK) or adjust ("ADJ") and enter a zero reading.
 - c. Apply span gas when requested.
 - Allow enough time for a stable reading.
 - d. Accept (OK) or adjust ("ADJ") and enter the correct span reading.
7. Remove the connector assembly and re-attach the sampling line to the monitor inlet.



WARNING

If the sampling line is not re-attached, the monitor cannot sample from the remote location. During calibration, the alarm relays do not activate; ensure that a hazardous condition does not exist when calibrating the CHILLGARD RT system.

Chapter 5 Maintenance

General Maintenance

Under normal operation conditions the Chillgard RT Monitor requires minimal maintenance. The end-of-sample-line filter(s) should be examined regularly for dirt/dust build-up and replaced when necessary. If the filter(s) become severely clogged with dust, the flow rate will eventually fail and a flow alarm will occur. If the end-of-sample-line filters are used and serviced correctly, the filters installed inside the monitor should rarely require replacement; however, these internal filters must be inspected periodically.

Obtaining Replacement Parts

To obtain replacement parts, address the order or inquiry to:

**MSA Corporate Center
1000 Cranberry Woods Drive
Cranberry Township, PA 16066
or call, toll-free, 1-800-MSA-INST.**



WARNING

Use only genuine MSA replacement parts when performing any maintenance procedures. Failure to do so may seriously impair unit performance. Repair or alteration of the Chillgard RT Monitor, beyond the scope of these instructions or by anyone other than authorized MSA service personnel, could cause the product to fail to perform as designed and persons who rely on this product for their safety could sustain serious personal injury or death.

Table 5-1. Replacement Parts

PART NO.	PART	
	Internal Filter, Single Point	711561
	Internal Filters, all Multipoint and single-point Ammonia	655533
	Filter, End-of-Line	711561
	Ammonia Unit, Filter, End-of-Line	655652
	2.0 amp, 250 volt Fuse	638091
	Display	655786
	Front Panel Printed Circuit Board Assembly (grey ribbon cable)	10014705
	Power Supply	637394
	Pump Assembly	711479
	Low Flow Switch	637824
	Polyurethane Tubing, 1/4" (6.4 mm) OD, 1/8" (3.2 mm) ID	603806
	Polyethylene Tubing, 1/4" (6.4 mm) OD, 0.17" (4.3 mm) ID	29264
	Nylon Tubing, 1/4" (6.4 mm) OD, 0.180" (4.6 mm) ID	29207
	*Teflon®-Lined Tubing	603876
	Equalization Valve	711371
	Strobe, Beacon Assembly	634674
	Gasket, Beacon Assembly	711168
	Connector, Beacon Assembly	637523
	Sonalert	629693
	Zero Gas Scrubber	803873
	Span Gas Scrubber	803874
	Front Panel Printed Circuit Board Assembly (black/orange cable)	711386
	Printed Circuit Board, Membrane Switch, Keypad	711340
	Label, Keypad	711374

*Trademark of E. I. DuPont Co.

Troubleshooting Guidelines (see TABLE 5-2)

Table 5-2. Troubleshooting Guidelines

TROUBLE	DESCRIPTION	SOLUTION
Unit will not turn ON	No power	<ol style="list-style-type: none"> 1. Check AC power to unit. 2. Verify AC power to unit is wired properly. 3. Replace L1 and/or L2 fuse. 4. Check for loose wires on terminal barrier input. 5. Check wiring to the unit power supply. Remove power supply cover and check fuse; replace if necessary. 6. Check input cable to main board on left side of power supply. 7. Check for 12 VDC power supply output. Connect the DVM negative lead to TP5 and the positive lead to TPSPD1. Adjust Volt 2 pot on the power supply if necessary. 8. Move the DVM positive lead to TPSPD3. The voltage should be 5 VDC. Adjust Volt 1 pot on power supply if necessary.
Beacon will not light	Beacon alarm	<ol style="list-style-type: none"> 1. Check that plug is connected to circuit board J10. 2. Verify audio option is used in the setup screens. 3. Replace beacon assembly.
Under-range failed	Zero limit is minus 10 ppm	<ol style="list-style-type: none"> 1. Adjust display zero to 0.0 via the keypad with zero air or zero scrubber applied. 2. Check zero air cylinder; replace if necessary. 3. Check the zero scrubber; replace if necessary.
Calibration failed	Coefficients out of range	<ol style="list-style-type: none"> 1. Replace zero scrubber or change zero air supply. 2. Check span gas supply. 3. Check all tubing, filters and fittings for leaks. 4. For sequencer units, make sure unit is locked on the selected sample port used for calibration. 5. Leak test the flow system. 6. Return to MSA for service.

TROUBLE	DESCRIPTION	SOLUTION
Bypass flow failed	Leaky or blocked bypass line	<ol style="list-style-type: none"> 1. Remove all input lines to unit. Attach one line at a time to check for bypass input. The line that causes flow failure is the problem; check the line's end-of-line filter. 2. Check inlet fitting, tubing, orifices, bypass pressure switch, and bypass manifold tubing. 3. Check pressure switch for 4 VDC ON and OFF switching (if sequencing); if single-point, it will be ON constantly. Check cable terminals and plug end at BP/SCN. Replace the bypass pressure switch if necessary. 4. Check operation of all bypass valves in manifold. 5. Leak test the flow system.
Start bypass flow failed	Leaky or blocked bypass line at unit startup	<ol style="list-style-type: none"> 1. Same as bypass flow failure. Check as above, turn unit OFF and restart unit. 2. Leak test the flow system and restart unit.
Sensor flow failed	Leaky or blocked sample line	<ol style="list-style-type: none"> 1. Remove all input lines to the unit. Attach one line at a time to check for sample input. Check all end-of-line sample filters. Sample flow failure is always the present point being sampled. 2. Remove the optical bench cover. Check the inlet fitting, tubing, sample filter, tubing to the optical bench inlet fitting, outlet fitting from the optical bench, sample pressure switch, and sample manifold tubing. 3. Check the sample pressure switch for 4 VDC ON and OFF switching. Check the cable terminals and plug end at press/sample connector. Replace pressure switch if necessary. 4. Check operation of all manifold sample valves. Check the optical bench inlet and outlet valves. 5. Check the optical bench inlet and outlet valve connectors on J22 and J21. 6. Leak test the flow system.
Start sensor flow failed	Leaky or blocked sample flow line at unit startup	<ol style="list-style-type: none"> 1. Same as sensor flow failure. Check as above; turn unit OFF and re-start unit. 2. Leak test the flow system.
Case temperature failed	Main board component	<ol style="list-style-type: none"> 1. Return to MSA for service.
Case temperature range failed	Case temperature is 0 to 90 °C	<ol style="list-style-type: none"> 1. Return to MSA for service.

TROUBLE	DESCRIPTION	SOLUTION
Thermostat sensor failed	Controls optical bench inside temperature	1. Replacement of optical bench requires MSA service
Sensor temperature range failed	Checks for temperature range of 45 to 90 °C	1. Replacement requires MSA service.
Humidity sensor failed	Checks H ₂ O sensor output	1. Return to MSA for service.
Infrared source failed	Checks the I of source assembly	1. Return to MSA for service
Photo synchro failed	Checks the chopper for operation	1. Return to MSA for service.
PA IR sensor failed	Checks the sensor microphone for output	1. Return to MSA for service.
Memory protect	Checks checksum	1. Return to MSA for service.
External reset failed	Checks the external reset button	1. If not used, check for jumper between RST minus and RST plus on J16. 2. If used, verify switch is wired normally closed.
Display failure	Display communications	1. Check RS485 connector on J15, terminals 1 and 2. 2. Check for broken or cracked display. 3. Remove rear panel cover and check cables between the display and the display board.
Audio alarm failure	Audio alarm	1. Check output terminals 6 and 7 on J17. 2. Check for faulty horn buzzer.

Chapter 6 Data Logging

Log Size

The Chillgard RT unit allows 1,078 sets of data and events to be logged. This data is either the maximum or average of the "last" data calculated.

Last Values

The maximum value is taken from the 'last' data; this is not always the highest value displayed, but the last valid data taken from a point. The average is an average of 'last' data values. Usually, the last data is the fourth reading during normal operation (or the twelfth reading if the monitor is in an extended dwell). Invalid (blank) and under-range data are not recorded. Over-range is recorded as 1000 ppm.

Number of Data Points Used

If the unit is only a single point monitor or all but one point is inactive, the value is recorded every sixteenth reading; this is 30 values per hour. With four points active, 15 values per point are recorded every hour. The number of values can be considerably lower if the monitor enters extended dwell because of high gas concentrations.

User Setup Options

When the monitor enters the Ready State, the data array is cleared. Then, four valid concentration values are needed before any data is recorded. Concentrations are recorded either every 15 minutes or hourly. If the logging function is turned OFF, the clock/calendar chip is stopped to save battery energy.

- Before the logging is turned ON, the clock/calendar must be set.

Setting any value starts the clock/calendar. Hours or days may be skipped or repeated. The log can be cleared in the Setup Menu.

Viewing Alarms/Events and Data

From the Review Events Screen, the user can view just alarms, just events, or both. The latest event is presented first. When the memory is filled, the entries wrap around.

From the Review Data Screen, the user can view the recorded concentrations. The particular point must be selected. Again, the latest data is presented first; when the memory is filled, the entries wrap around.

Appendix A Check List

Before applying power to the Chillgard RT Refrigerant Monitor, check for all items in the following table:

ITEM	CHECK FOR:	CHECKED OR INITIALED
1	Proper mounting of Chillgard RT Refrigerant Monitor on a non-vibrating surface which does not block the front panel. Mounting must be away from direct solar heating.	
2	Correct electrical connections and wiring to Chillgard RT Refrigerant Monitor. Wiring must be done for proper voltage.	
3	Proper tubing for sample line.	
4	Removal of all caps and plugs at sample line inlets and exhaust.	
5	Proper end-of-line filters installed.	
6	Disabling of unused sampling points.	
7	Possession of proper calibration kit and check gases for calibration.	
8	An established routine calibration schedule.	



Refrigerant Monitor Startup Report "Chillgard RT"

Project: _____ Date: _____
Model #: _____ Serial No: _____
Customer: _____ Tech: _____
Notes: _____

<p><u>Unit</u></p> <p>Power: _____</p> <p>Display: _____</p> <p>Tubing: 1 2 3 4 5 6 7 8</p> <p>Filters: 1 2 3 4 5 6 7 8</p> <p>Installation Notes _____</p> <p>_____</p> <p>_____</p> <p><u>Calibration</u></p> <p>Channel _____</p> <p>Gas Used _____</p> <p>Span <input type="checkbox"/> _____</p> <p>Zero <input type="checkbox"/> _____</p> <p>Cal Check <input type="checkbox"/> _____</p> <p><u>Sequence</u></p> <p>1 2 3 4 5 6 7 8</p> <p>_____</p> <p><u>Alarms</u></p>	<p>Caution _____ PPM</p> <p>Dwell _____ %</p> <p>Warning _____ PPM</p> <p>Alarm _____ PPM</p> <p><u>Latching</u></p> <p>Caution <u>Latch / Unlatch</u></p> <p>Warning <u>Latch / Unlatch</u></p> <p>Alarm <u>Latch / Unlatch</u></p> <p><u>Alarm Relays</u></p> <p>Caution <u>DeEnerg / Energ.</u></p> <p>Warning <u>DeEnerg / Energ.</u></p> <p>Alarm <u>DeEnerg / Energ.</u></p> <p><u>Audio Alarms</u></p> <p>Caution <u>No Audio / Set</u></p> <p>Warning <u>No Audio / Set</u></p> <p>Alarm <u>No Audio / Set</u></p> <p>Aux <u>No Audio / Set</u></p> <p>Trouble <u>No Audio / Set</u></p> <p><u>Auxiliary Alarms</u></p>	<p><u>Equipped</u> <u>Yes / No</u></p> <p><small>If equipped with Auxiliary sensor, note settings on 2nd Page.</small></p> <p><u>Analog Output</u></p> <p>Volt <u>100% 10%</u></p> <p>MA <u>100% 10%</u></p> <p>Cal V <u>Read Neg</u></p> <p>Cal MA <u>Read Neg</u></p> <p><u>Time</u></p> <p>Done <input type="checkbox"/> _____</p> <p><u>Logging</u></p> <p>Rate <u>Hour /15 Min /Off</u></p> <p><u>Password</u></p> <p>Set <u>Enable / Disable</u></p> <p>Password _____</p>
--	---	--

Appendix B Relay Module

This accessory module has not be evaluated by Underwriters Laboratory, Inc.

General Description

The Chillgard RT Relay Module is intended to provide discrete relay outputs for the Chillgard RT Refrigerant Monitor equipped with a multi-point sequencer.

The Chillgard RT Refrigerant Monitor has three alarm threshold levels (CAUTION, WARNING, and ALARM), each with a corresponding form C relay output. The user can obtain alarm level information via the set of three relay contacts.

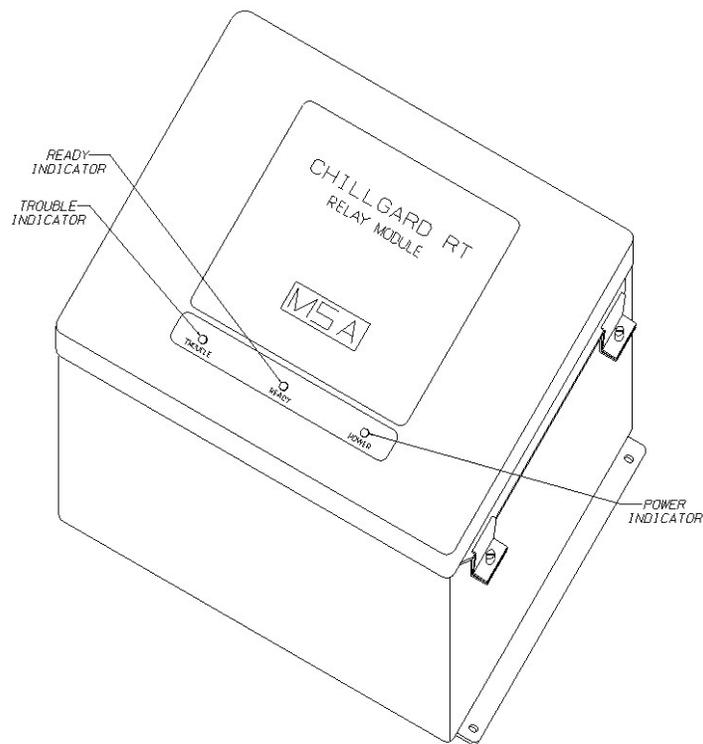

Figure B-1. Relay Module

The Chillgard RT Refrigerant Monitor relays do not convey point-wise alarm level information. These relays provide information at the monitor level only, one set of relay contacts (CAUTION, WARNING and ALARM) per sequencer point. Used as intended, the Chillgard RT Relay Module enables the user to obtain point-wise alarm level information.

The Chillgard RT Relay Module monitors the current state of the Monitor and sets its installed relays according to information received. While the Chillgard RT Relay Module receives its information from the Chillgard RT Refrigerant Monitor, it is important to note that the Relay Module operates independently with respect to the Reset Switch and Audio operation. Refer to "Operation" later in this appendix for details.

NOTE: The use of ALARM in capital letters refers to the specific Chillgard RT Refrigerant Monitor third alarm threshold level.

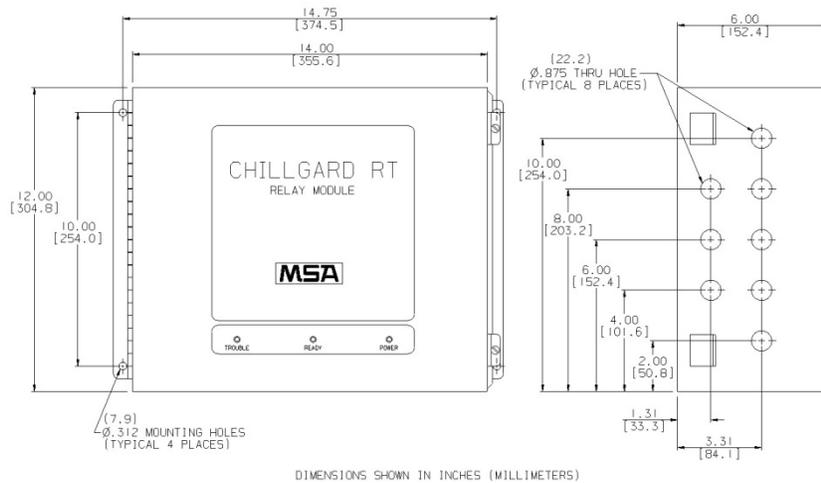

Figure B-2. Mounting the Relay Module

Specifications

Table B-1. Specifications

TEMPERATURE RANGE	OPERATING	0 to 50°C
	STORAGE	-20 to 60°C
POWER		85 - 264 Volts @ 40 Watts max.
MAXIMUM WARM-UP TIME		30 seconds
HUMIDITY		0 to 99% RH non-condensing
SYSTEM COMMUNICATION		RS-485
RELAYS	COMMON TROUBLE AND HORN RELAY	10 Amps @ 125, 250 VAC 10 Amps @ 30 VDC
	CAUTION, WARNING AND ALARM RELAYS	4 Amps, 1/20 H.P. @ 125, 250 VAC 3 Amps @ 30 VDC
	TERMINAL BLOCK	can accept up to 12 AWG wire
HORN		80 db (2 feet [61 cm] at ambient temperature and pressures)
DIMENSIONS		12.5" wide x 6.5" deep x 15" high (31.8 cm wide x 16.5 cm deep x 38.1 cm high)
WEIGHT		Approximately 25 lbs. (12 kg)

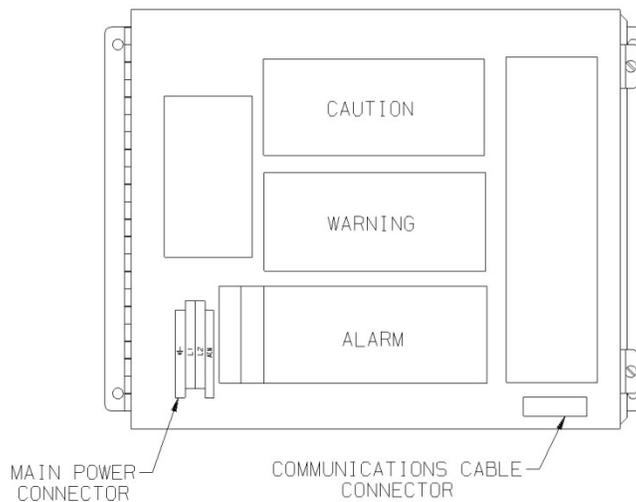

Figure B-3. Relay Module Main Power Connector and Communication Cable Connector Locations

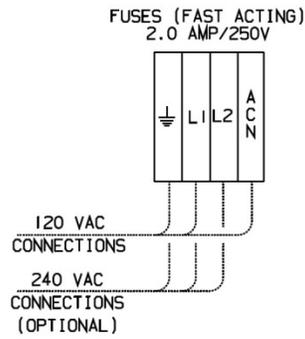

Figure B-4. Chillgard RT Relay Module Power Wiring Diagrams for 120 Volts and 240 Volts AC

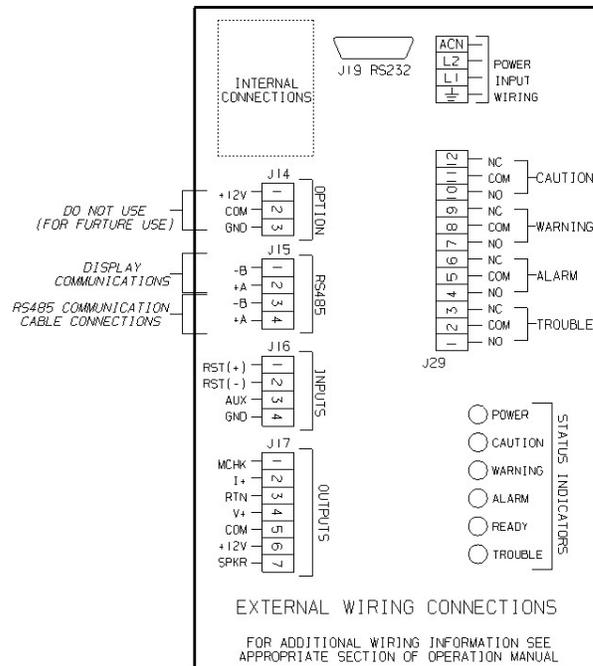

Figure B-5. Chillgard RT Refrigerant Monitor Communication Cable Connections

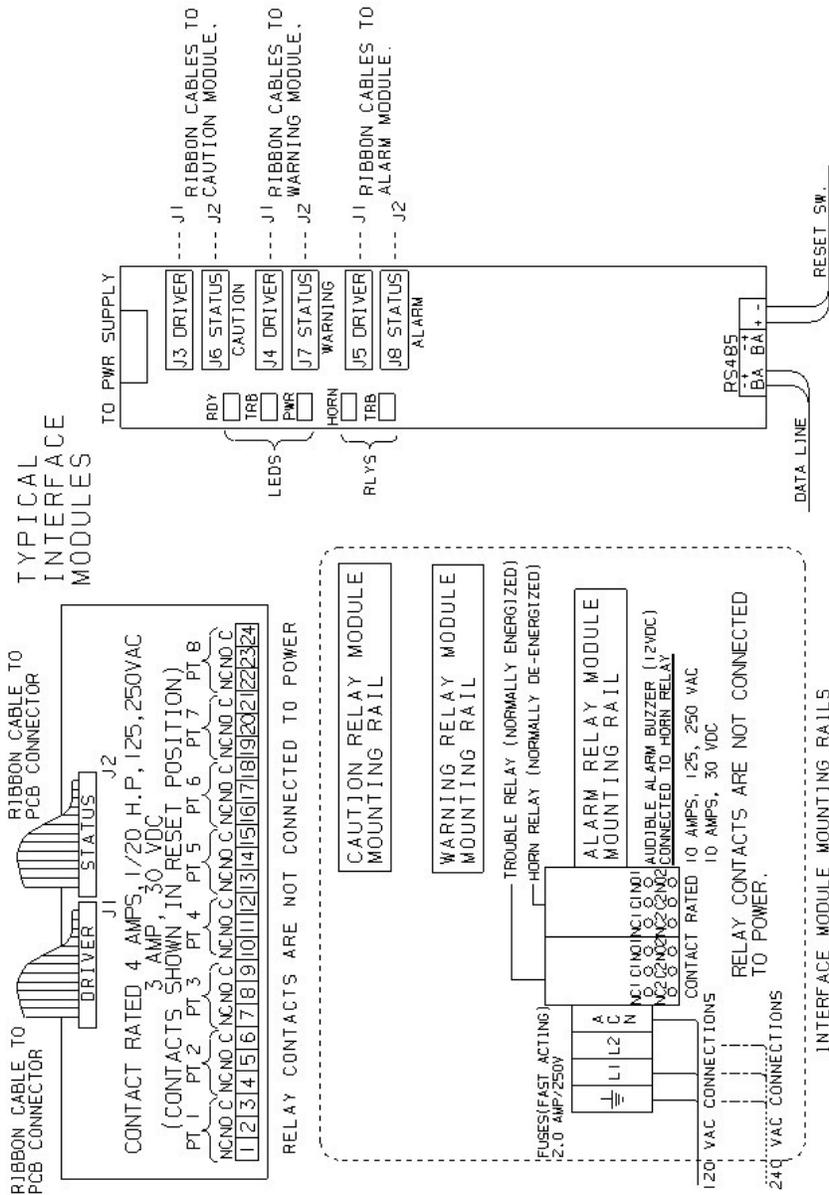

Figure B-6. Typical Interface Modules

Unpacking the Shipping Carton

The shipping carton should contain the Chillgard RT Relay Module.

Identifying the Unit

Each bank of relays (see FIGURE B-3) is assigned to a particular alarm level. Chillgard RT Relay Modules can be purchased with one, two, or three internal relay banks (TABLE B-2).

Table B-2. Part Numbers and Supplied Relays

UNIT P/N	RELAY P/N	QUANTITY OF RELAYS	DESCRIPTION	DEFAULT RELAY ASSIGNMENT
710847	COMPLETE UNIT	N/A	1 BANK OF RELAYS	ALARM
710847	490558	1	2 BANKS OF RELAYS	WARNING ALARM
710847	490558	2	3 BANKS OF RELAYS	CAUTION WARNING ALARM

The default relay assignment may be changed. Consult the factory for more information.

Mounting Your Unit

Mount the Chillgard RT Relay Module adjacent to the controlling Chillgard RT Refrigerant Monitor using the four mounting holes as shown in FIGURE B-2 (hardware not supplied).

Electrical Connections for the Chillgard RT Relay Module

Follow all applicable practices and local codes. Use appropriate conduit and cable glands when installing the Chillgard RT Relay Module and Chillgard RT Refrigerant Monitor.

Main Power Connections

Ensure that all primary power is turned OFF at the circuit breaker or fuse. Do not wire the Chillgard RT Relay Module with power ON.



CAUTION

Wiring the Chillgard RT Relay Module with the power ON may result in electrocution which may cause injury or death.

Identify the main power voltage that will power the Chillgard RT Relay Module; if unsure of your primary power, consult an electrician or local power utility.



WARNING

Application of improper power to the Chillgard RT Relay Module will result in damage to the unit.

Refer to FIGURES B-3, B-4 and B-5 to identify the location of the main power connections within the Chillgard RT Relay Module.

1. Locate the power wiring entry on the lower left hand side of the unit and remove the hole plug.
2. Route the power wiring through the hole using proper hardware/conduit (not supplied).
3. Strip the power wiring conductors.
4. Insert each stripped conductor into its proper location in the power cable connector (FIGURE B-4).
5. Tighten each screw within the connector to secure each wire.
6. Pull on each wire to ensure that it will remain in place. If a wire comes out of the connector, loosen the screw, reinsert the wire, and re-tighten the screw.
7. The Relay Module must have the same electrical ground as the Monitor unit.

Communication Cable Connections

Use the factory-recommended RS485 communication cable. Low capacitance wire for RS485 communications, such as Beldon #9841, is recommended.



CAUTION

Maximum length of the communication cable is 1000 feet (305 m); otherwise, the Chillgard RT Relay Module will not operate properly.



WARNING

Use only the recommended cable. Using inferior or wrong communication cable causes improper operation of the Chillgard RT Relay Module.

Do not exceed the maximum length of communication cable listed; otherwise, the Chillgard RT Relay Module may not operate properly and may not indicate a trouble condition.

Communication Cable Connections to the Chillgard RT Relay Module

1. Locate the RS-485 communication cable inside the Chillgard RT Relay Module enclosure.
2. Locate the eight cable entries on the right side of the relay module (FIGURE B-2). From these eight cable entries, choose one of the three bottom entries and remove the hole plug.
3. Route the communication cable through the hole using proper hardware (not supplied) to secure the cable. A 30 mm distance must be maintained between this communication cable and the electronic assembly or power line feeds.

Communication Cable Connections to the Chillgard RT Refrigerant Monitor

1. Route the communication cable to the Chillgard RT Refrigerant Monitor.
2. Find an unused entry in the Chillgard RT Refrigerant Monitor enclosure and remove the hole plug.
3. Route the communication cable through the hole using proper hardware (not supplied) to secure the cable.
4. Strip each communication cable conductor.
5. Insert each stripped conductor into its proper location on the communication cable connector (Refer to FIGURE B-5 for connector location and function designation). The connector labeled "+" on the Relay Module must be connected to the RS485 connector labeled "+" on the Refrigerant Monitor. Likewise, the connector labeled "-" on the Relay Module must be connected to the RS485 connector labeled "-" on the Refrigerant Monitor.
6. Tighten each screw within connector to secure each wire.
7. Pull on each wire to ensure that it will remain in place. If a wire comes out of the connector, loosen the screw, reinsert the wire, and re-tighten the screw.

Relay Wiring

Before installing any wiring to the relays within the Chillgard RT Relay Module, refer to the manual for the specific equipment being connected to the relays for wiring procedures and requirements. If your unit is a four-point Chillgard RT model, use the first four relays. The remaining four relays within the bank are not used.



WARNING

Use the proper size wire to any equipment connected to the Chillgard RT Relay Module relay; otherwise, a fire or electrical damage may result.

1. Refer to FIGURE B-2 for the relay wiring entries into the Chillgard RT Relay Module.
2. Remove the hole plug(s) required and route the relay wiring through the hole(s) using proper hardware/conduit (not supplied).
3. Strip each relay wiring conductor.
4. Determine the relay functions necessary (see front door label for relay locations and contact information). Insert each stripped relay wiring conductor into the connector for the desired function.
5. Tighten each screw within the connector to secure each wire.
6. Pull on each wire to ensure that it will remain in place. If a wire comes out of the connector, loosen the screw, reinsert the wire and re-tighten the screw.
7. Once wiring is complete, close and secure the front panel of the Chillgard RT Relay Module.



CAUTION

Do not allow the front panel of the Chillgard RT Relay Module to remain open during use.

Operation

Front Panel Indicators

(see FIGURE B-1).

Power Indicator

The power indicator shows that power is properly applied to the unit.

- If this indicator is not ON when power is applied, refer to the Section 4, Troubleshooting Guidelines.

Trouble Indicator

The Trouble Indicator turns ON and remains ON when a trouble condition is detected. The trouble condition may exist at the controlling Chillgard RT Refrigerant Monitor or it may exist locally at the Chillgard RT Relay Module.

Possible trouble conditions:

- Chillgard RT Remote Relay Module losing communication with the Chillgard RT Refrigerant Monitor for longer than two seconds
- Refrigerant Monitor internal trouble
- Relay Module inoperative relay.

See Section 4, Troubleshooting Guidelines for other possible trouble conditions.

Ready Indicator

- The Ready Indicator turns ON and stays ON when the controlling Chillgard RT Refrigerant Monitor is ready and Relay Module is operating properly
- This indicator remains OFF during the initial warm-up
- This indicator remains OFF during the initial Chillgard RT Refrigerant Monitor warm-up, setup and calibration.

Chillgard RT Relay Module Relays

There are three types of relays in the Chillgard RT Relay Module:

- common horn relay
- common trouble relay
- discrete alarm relays

The Common Horn Relay:

- is a double-pole, double-throw (DPDT) type relay
- contacts are normally connected to equipment to alert personnel of an alarm condition

The Trouble Relay:

- is a double-pole, double-throw (DPDT) type relay
- is normally-energized during normal operation for fail-safe operation
- de-energizes if power is removed
- contacts may be connected to equipment to alert personnel that a trouble condition exists

The Discrete Caution, Warning and Alarm Relays:

- are single-pole, double-throw (SPDT) type relays.
- contacts may be connected to equipment to alert personnel that an alarm condition exists.

Applying Power

Apply power to the Chillgard RT Refrigerant Monitor and Chillgard RT Relay Module. The Power Indicator on the Relay Module should illuminate.

The Trouble Relay in the Relay Module will energize when communications from the Chillgard RT Refrigerant Monitor have been received, no internal relay faults have been detected, and the Chillgard RT Refrigerant Monitor is not in the Trouble state.

The Ready Indicator will illuminate when the Chillgard RT Refrigerant Monitor is in the Ready state, and the conditions described above remain valid.

Note that during the Warm-Up state of the Chillgard RT Refrigerant Monitor, all alarm relays in the Relay Module are cleared.

Alarm Relay Configuration**Latching**

The configuration of all alarm relays is controlled by the Chillgard RT Refrigerant Monitor.

- If the Chillgard RT alarm relay (CAUTION, WARNING, ALARM) is configured as latching, all eight relays of the corresponding bank in the Relay Module are configured for latching operation.
- Likewise, if the Chillgard RT alarm relay (CAUTION, WARNING, ALARM) is configured as non-latching, all eight relays of the corresponding bank in the Relay Module are configured for non-latching operation.

Normally Energized/De-energized

While the alarm relays in the Chillgard RT Refrigerant Monitor can be configured as either normally energized or normally de-energized, all alarm relays in the Chillgard RT Relay Module are magnetically latching; therefore the normally energized/de-energized designations do not apply. The contact labels "normally open," "normally closed" and "common" are assigned for convenience. The "normally open" contacts

close and "normally closed" contacts open to signal an alarm condition. These relays DO NOT change state when power is removed.

Operation

Proper operation of the alarm relays requires maintaining successful communication between the Relay Module and the controlling Chillgard RT Refrigerant Monitor since all alarm relay operations are based on cumulative information received from the Refrigerant Monitor.

Alarm level information for each point of the multi-point sequencer is received from the controlling Chillgard RT Refrigerant Monitor. This information is used to set the CAUTION, WARNING, and ALARM relays corresponding to each sequencer point.

- In non-latching configurations, relay(s) will reset when information from the controlling Refrigerant Monitor indicates that the alarm condition(s) for the specific point has abated.
- In latching configurations, relay(s) remain set (latched) when the condition abates, and do not reset until the Relay Module reset switch is pressed.

Reset Switch

The reset switches of the Chillgard RT Relay Module and controlling Chillgard RT Refrigerant Monitor act independently. Pressing the reset switch on the Refrigerant Monitor does not affect the Relay Module alarm relays, and pressing the reset switch on the Relay Module does not affect the Refrigerant Monitor alarm relays.

- In non-latching configurations, the Relay Module reset switch does not affect the state of the alarm relays.
- In latching configurations, the reset switch resets the alarm relay only if the alarm condition has abated.

Trouble Relay

While a trouble condition in the Chillgard RT Refrigerant Monitor activates the trouble relay in the Chillgard RT Relay Module, a trouble condition in the Relay Module does not activate the trouble relay in the controlling Chillgard RT Refrigerant Monitor.

Horn Operation

Configuration

The configuration of the horn relay is controlled by the Chillgard RT Refrigerant Monitor.

- The Horn Relay in the Relay Module is configured by the “Caution sets Audio Alarm,” “Warning sets Audio Alarm,” “Alarm sets Audio Alarm” and “Trouble sets Audio Alarm” configuration in the Chillgard RT Refrigerant Monitor.
- The “Aux sets Audio Alarm” and “Trouble sets Audio Alarm” configurations of the Refrigerant Monitor apply to the Relay Module Horn relay.
- The Horn relay of the Relay Module is only latching when the alarms are configured latching in the Chillgard RT Refrigerant Monitor.

Reset Switch

The reset switches of the Chillgard RT Relay Module and controlling Chillgard RT Refrigerant Monitor act independently. Pressing the reset switch on the Refrigerant Monitor does not affect the Relay Module horn, and pressing the reset switch on the Relay Module does not affect the Refrigerant Monitor horn. If the Chillgard RT Relay Module reset switch has been used to silence the Relay Module horn, and any alarm condition (configured to activate the horn) occurs at a new sequencer point, the horn relay will activate to signal the new alarm condition.

Maintenance

Under normal operating conditions, the Chillgard RT Relay Module requires no maintenance. However, periodic testing of the relays may be done to ensure that complete system operation is possible.

Troubleshooting Guidelines

Table B-3. Troubleshooting Guidelines

SYMPTOMS	POSSIBLE CAUSES	CORRECTIVE ACTION
Alarms do not activate	Chillgard RT Refrigerant Monitor alarms not enabled or communication is lost	Enable alarms at the Chillgard RT Refrigerant Monitor
		Check wiring
	Inoperative processor board	Check power supply Replace processor board
Trouble LED flashes	Loss of communication	Check wiring between Chillgard RT Refrigerant Monitor and Relay Module
		Check power wiring or power supply
		Check wiring in the Chillgard RT Relay Module
Power LED not ON	Power fault	Check wiring, power supply and fuse
Trouble LED ON	Relay trouble or controlling Chillgard RT Refrigerant Monitor in Trouble state	Check relay and relay wiring within Chillgard RT Relay Module

Obtaining Replacement Parts

To obtain replacement parts, address the order or inquiry to:

**MSA Corporate Center
1000 Cranberry Woods Drive
Cranberry Township, PA 16066
or call, toll-free, 1-800-MSA-INST.**

Table B-4. Replacement Parts

ITEM	PART NO.
Relay Board (PCB)	490558
Power Supply Board (PCB)	655116
Processor Board (PCB)	710392

Appendix C RS-232 Output

Introduction

Your Chillgard RT Gas Monitor is ordered and built for the particular types of gas in use. The monitor full scale range may differ from the standard 0 to 1000 ppm range. Check the calibration label on the reverse side of the front cover (FIGURE C-1) to determine your instrument's full scale range.

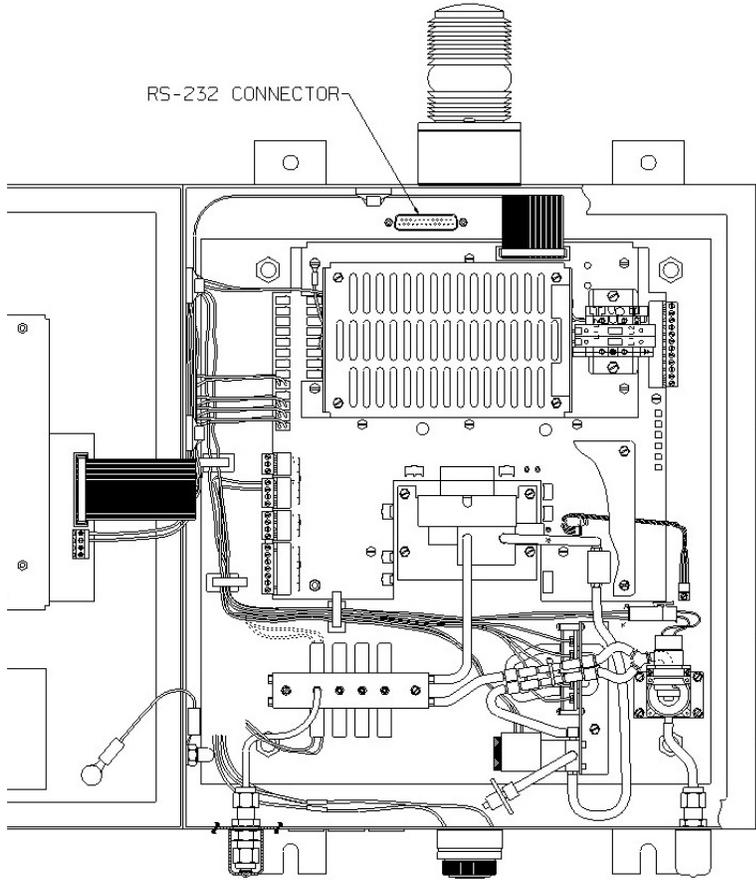

Figure C-1. RS-232 Location

The instrument is ready to monitor; however, it is necessary to configure the unit to your specific requirements. Your Chillgard RT Gas Monitor may contain an internal Multi-Point Sequencer, enabling your unit to sample from up to eight individual sampling locations. Your unit also contains several other features described in this appendix:

- RS-232 output
- Remote Front Panel capability
- Sampling point identification.

Table C-1. RS-232 Parameters

COMMUNICATION PARAMETERS	9600 Baud 8 bits No parity One stop bit
-----------------------------	--

Three types of messages can be transmitted from the RS-232 port:

- status
- data and
- events.

Status

Status is the first message.

- The first seven characters are the gas type.
- The next three characters are the point number, followed by the concentration and the units.
- The second line is the instrument state and the alarm level.
- The Trouble State shows the type of fault detected; see TABLE C-2
- This message is sent every 10 seconds.

Data Logged Value

The data logged value is the next message.

- The first line indicates the date and time.
- The second line shows the:
 - point
 - gas type and
 - logged concentration.
- The message is generated for every point and sent every 15 minutes or hourly, depending on the setup selection.
- The concentration is an average or the maximum values for the selected time frame; see TABLE C-3.

Alarm Events

Alarm events is the last message type.

- The first line is the date and time.
- The second name is the:
 - point
 - gas name and
 - alarm level.
- See TABLE C-4.

All of these messages are initiated by the sync character, followed by a binary address byte, 40 ASCII characters, and terminated with a line feed and carriage return.

STATUS MESSAGE		CONC UNITS
GAS	PTX	ALARM/AUX
STATE		TROUBLE TYPE
0	SYNC	0x16
1	address	0x01 -> 0xff
2	A	
3	M	
4	M	
5	O	
6	N	
7	I	
8	A	
9		
10	P	
11	T	
12	1	2 3 4 5 6 7 8
13		
14	1	
15	0	
16	0	
17	0	
18		
19	P	
20		
21	M	
22	W	
23	A	U N K N O W N
24	R	T R O U B L E
25	A	C A L S E T
26	D	
27	U	
28	P	
29		
30		
31		
32	C	A U X
33	A	A U X
34	A	A L A R M
35	L	A L A R M
36	A	A L A R M
37	R	F A L L
38	N	A L A R M
39	I	
40	O	
41	N	
42	G	
43	CR	0x0d
	LF	0x0a

Table C-2. Status Message

DATA LOGGING

MONTH DATE YEAR TIME
 POINT TYPE CONC UNITS

OPTION 1 -----> OPTION 2 ----->

sync	0x16							
address	0x01 - 0xff							
N								
.								
3								
1								
.								
2								
0								
0								
4								
2								
3								
:								
5								
9								
P	P	P	P	P	P	P	P	P
T	T	T	T	T	T	T	T	T
1	2	3	4	5	6	7	8	
A	A	A	A	A	A	A	A	A
M	M	M	M	M	M	M	M	M
M	M	M	M	M	M	M	M	M
O	O	O	O	O	O	O	O	O
N	N	N	N	N	N	N	N	N
I	I	I	I	I	I	I	I	I
A	A	A	A	A	A	A	A	A
1	1	1	1	1	1	1	1	1
0	0	0	0	0	0	0	0	0
0	0	0	0	0	0	0	0	0
0	0	0	0	0	0	0	0	0
P	P	P	P	P	P	P	P	P
P	P	P	P	P	P	P	P	P
M	M	M	M	M	M	M	M	M
cr	0x0d							
lf	0x0a							

Table C-3. Data Logging

ALARM LOGGING			
	MONTH	DATE	YEAR
	POINT	TYPE	TIME
			ALARM
<i>sync</i>	0x16		
<i>address</i>	0x01 - 0xff		
J			
A			
N			
.			
3			
1			
.			
2			
0			
0			
4			
2			
3			
:			
5			
9			
P			
T			
X			
A			
M			
M			
O			
N			
I			
A			
C	W	A	
A	A	L	
U	R	A	
T	N	R	
I	I	M	
O	N		
N	G		
<i>cr</i>	0x0d		
<i>lf</i>	0x0a		

Table C-4. Alarm Logging

RS-232 Output

The RS-232 output broadcasts certain information about the Chillgard RT Gas Monitor (TABLE C-3). This output conforms to the specification for RS-232 signal levels and is capable of driving its signal up to 200 feet (61 m) when using low capacitance RS-232 cable. See FIGURE C-1 for RS-232 connector location.

Connection to the RS-232 output is via a 25-pin sub "D" female connector. See FIGURE C-2 for the wiring definition. To enable this communication, pins 4 and 5 on the sub "D" connector must be connected. FIGURE C-2 shows the connector and wiring as it is wired to a computer. FIGURE C-3 shows the rear view wiring of the connector.

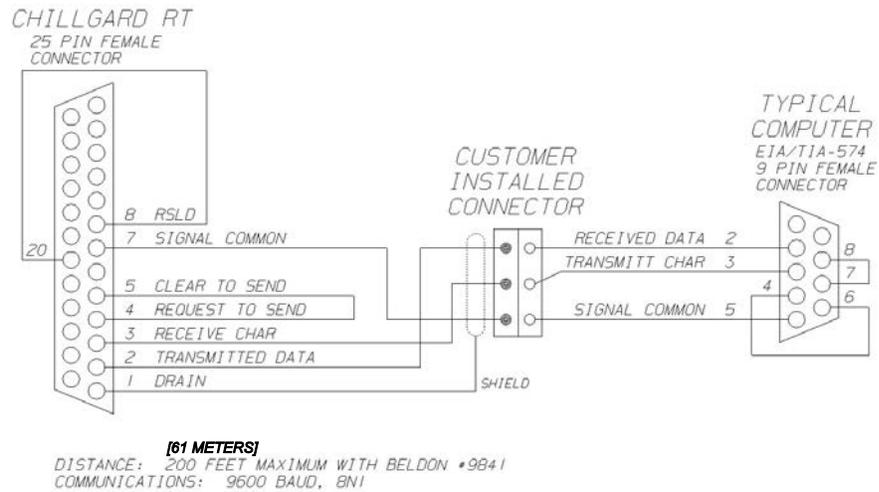

Figure C-2. Typical RS-232 Wiring

When connecting RS-232 cable to the instrument:

- The strain relief cover or shell on the 25-pin sub "D" connector must be removed. It is not possible to use a pre-wired or molded cable because its shell or strain relief is not removable. The connector's shell or strain relief does not fit within the instrument.
- It may be necessary to remove the metal covers from the printed circuit boards to attach the 25-pin sub "D" connector to its mate on the unit. If the metal covers are removed, replace them when the cable's connector is mated to the connector on the printed circuit board.

Remote Gas Sampling Channel Identification

Chillgard RT Monitors have two analog outputs:

- 4-20 mA and
- 0-10 Volts.

The voltage output can be programmed to correspond to the channel presently being sampled. The front panel screen indicates:

1V/PT IF OUT = 1-10V

(1 volt per point if output equals one to 10 volts). When enabled and the unit is monitoring from:

- channel 1, the voltage output is one volt
- channel 2, the voltage output changes to two volts.

Table C-5. Voltage Output Corresponds to Channel

CHANNEL NUMBER	VOLTAGE OUTPUT
1	1
2	2
3	3
4	4
5	5
6	6
7	7
8	8

During unit setup, configure the voltage output to stepping, thus enabling the voltage output to reflect the channel being sampled.

Appendix D Multi-refrigerant Capability*

* This capability has been evaluated by Underwriter Laboratory, Inc. for the gases listed in TABLE D-1.

Introduction

The Chillgard RT Refrigerant Monitor is available with the capability to detect up to six different refrigerant gases. This capability is used when multiple chillers using different refrigerants are located together or in separate machinery rooms. Only one Chillgard RT Refrigerant Monitor is necessary. This reduces the initial expense as well as installation, wiring and cost of ownership expenses.

Your Chillgard RT Refrigerant Monitor is ordered and built for the particular types of refrigerants in use. The instrument is ready to monitor; however, it is necessary to configure the unit to your specific requirements.

Your Chillgard RT Refrigerant Monitor contains an internal Multi-Point Sequencer, enabling your unit to sample from up to eight individual sampling locations. Each sampling point of the Multi-Point Sequencer must be assigned one of the refrigerant gas types. This allows the unit to correctly detect and compute the proper readings for the gas type specified for that point.

Specifications

Table D-1*. Multi-Refrigerant Chillgard RT Refrigerant Monitor

TYPICAL REFRIGERANT GASES DETECTED (UL APPROVED)	R-11 R-12 R-22 R-114	
(OTHER GASES AVAILABLE UPON REQUEST BUT NOT EVALUATED BY UL)	R-123 R-134a R-113 R-404a R-500 R-502	
TEMPERATURE EFFECT	±0.3 % / °C of reading for 0 to 35°C +0.6 % / °C of reading for 35°C to 50°C	
RESPONSE TIME	500 FT. (152 M) OF SAMPLING TUBING LENGTH	13 minutes for a 90% step change
	150 FT. (46 M) OF SAMPLING TUBING LENGTH	105 seconds for a 90% step change

**Table D-2.
 Typical Cross Sensitivity
 at 100 Parts Per Million (PPM) at 25°C
 for the Chillgard RT Refrigerant Monitor
 Calibrated at 1000 PPM R11
 as Expressed in Response Factors**

REFRIGERANT SELECTED	RESPONSE FACTOR	100 PPM APPLIED
R11	1.00	100
R12	0.54	54
R22	1.07	107
R114	0.53	53
R123	1.09	109
R134a	0.99	99

Identifying Your Unit

After your unit is installed, open the front door and locate the Calibration Label (FIGURES D-1 and D-2). Also see the Manufacturing Date Label (FIGURES D-1 and D-3). If the Chillgard RT Refrigerant Monitor is built with multiple refrigerant gas capability, the calibration label shows what gases the unit can detect. Since it is possible to put up to six different gases on the unit, it is important to correctly install the sampling tubing and to identify which gases will be detected on each sampling point.

Installation

Install the Chillgard RT Refrigerant Monitor according to Section 2, "Installation and Set-up." However, do not connect any sampling lines to the unit at this time.

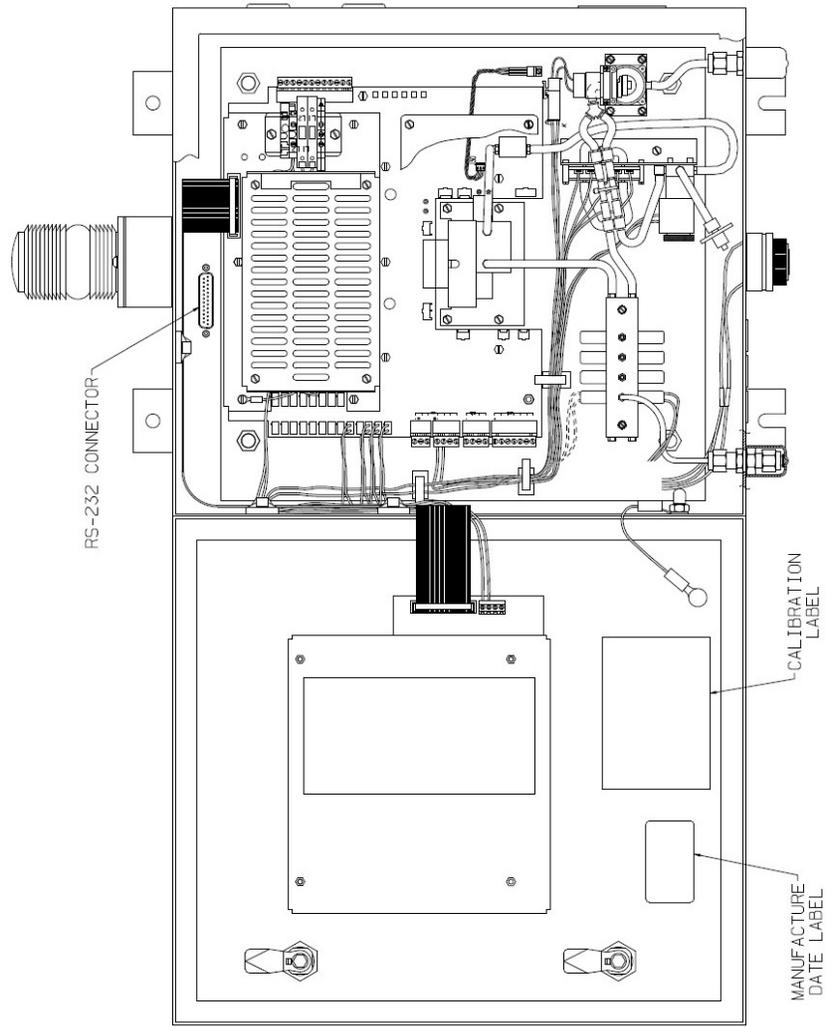

Figure D-1. Label and RS-232 Location

BENCH TYPE		BENCH S/N		UNIT ID	
A ZERO COEFF			H ZERO COEFF		
GAS TYPES					
A SPAN COEFF					
A POLY COEFF					
H COMP COEFF					
T ZERO	T SPAN		T POLY		
V ZERO COEFF	V SPAN COEFF				
I ZERO COEFF	I SPAN COEFF				

Figure D-2. Calibration Label

Factory Performance Test/Verification
Calibration Gas Mixture: _____
Synthetic Span: _____
MSA Cylinder P/N: _____
Cylinder Reading: _____
Certified Sensitivity Range: _____
Certified Accuracy: <u>See Installation Literature Specifications</u>
Test Date: _____
Test Reference Number: <u>See Unit Serial Number</u>
Instruction Manual Revision Number: _____
Inspector: _____

Figure D-3. Manufacture Date Label

Initial Setup

The Chillgard RT Refrigerant Monitor with multiple refrigerant detection capability must be programmed at the time of installation. This allows the unit to respond correctly to the gas expected at each particular sampling point. During set-up, a menu option relates each sampling point to one of the gases the instrument is capable of detecting.



WARNING

The Chillgard RT Refrigerant Monitor will only report proper gas readings if the particular gas selected to be monitored at each sampling point is actually present at that point. If another refrigerant that the Chillgard RT unit is capable of monitoring enters the sample line, the reading will not be accurate.

After installing the Chillgard RT according to the instructions in this manual, determine which refrigerant gas is likely to enter each sample line. Mark each sample line and place the sample tubing on one of the inlet ports. See FIGURES 3-1 through 3-12 and FIGURES 3-15 through 3-19 for proper set-up.

NOTE: Also see FIGURES D-4 through D-6 for Gas by Point Setup Screens and Alarm Level Screens (all other operating characteristics of the Chillgard RT Refrigerant Monitor remain unchanged).

Calibration

It is only necessary to calibrate the instrument with one gas, even though the Chillgard RT Refrigerant Monitor with multiple gas detection capability can respond to up to six different refrigerant gases. Calibrate the instrument according to the instructions in this manual.

The only variation of the calibration procedure for the multi-gas Chillgard RT Refrigerant Monitor is to apply span gas to only one of the sample points. The particular sampling point chosen must be configured to monitor that particular gas. During the calibration process, the span values of the other channels or gases will be corrected appropriately.

Display Screens

The Chillgard RT Refrigerant Monitor with multiple Gas Detection capability uses display screens which differ slightly from the standard unit. The different display screens are in the Setup of the Sequencer section of the instrument.

The screen in this section allows the user to define the refrigerant gas that is expected at each sampling point. Also, they determine which refrigerant gas is used for calibration by selecting the sampling point configured for that particular gas.

Following are sample screens that differ from the Section 3, "Display Screens":

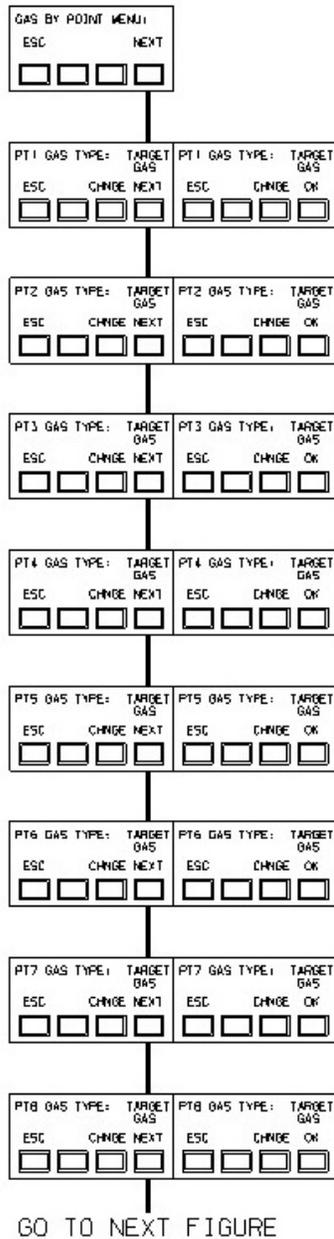

Figure D-4. Gas by Point Setup Screens

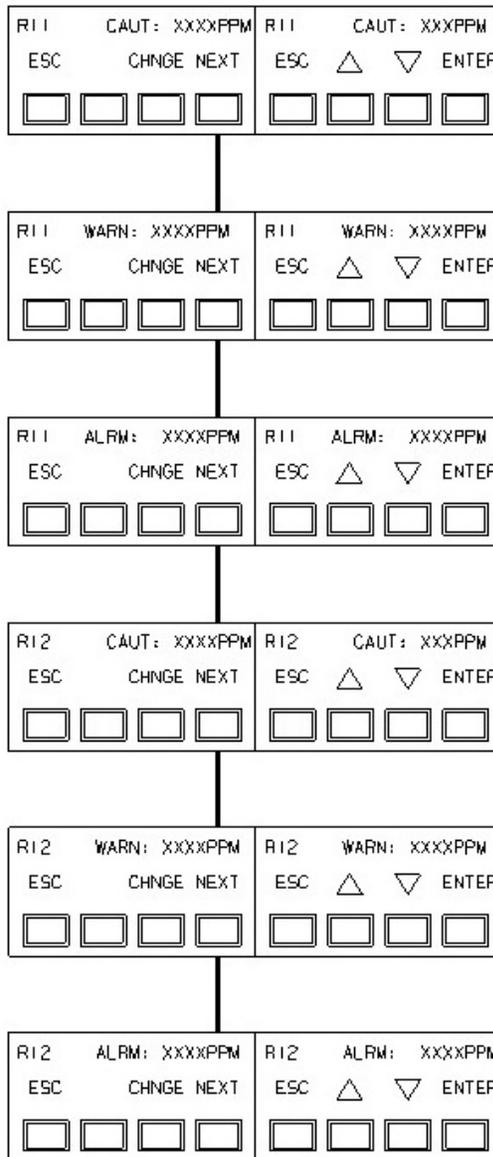

Figure D-5. Alarm Level Screens

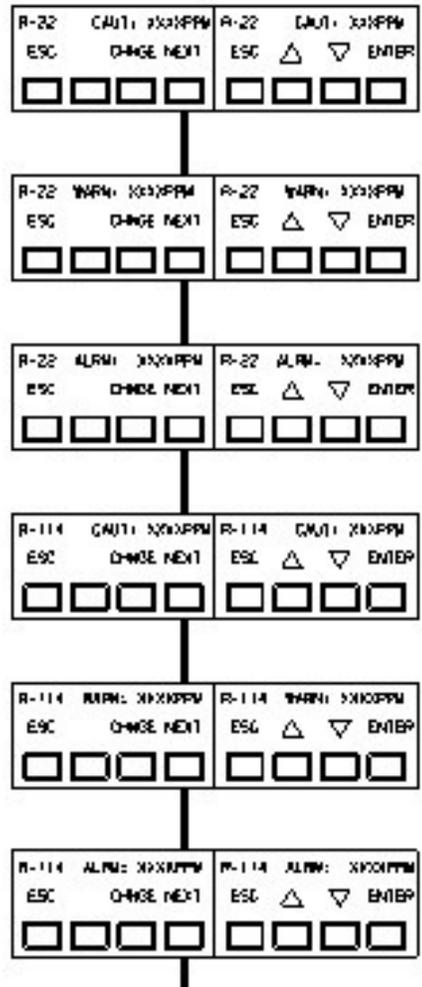

Figure D-6a. Alarm Level Screens

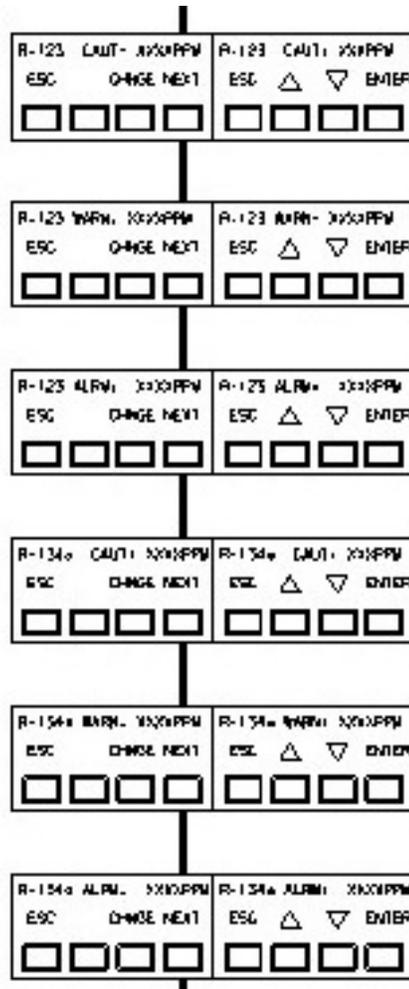

Figure D-6b. Alarm Level Screens

For local MSA contacts, please visit us at **[MSAafety.com](https://www.MSAafety.com)**

*Because every life has a **purpose...***