

# **PremAire® Cadet Escape Respirator: Second Stage Regulator**

**MAINTENANCE AND REPAIR**

For More Information, call 1-800-MSA-2222 or Visit Our Website at [www.MSAnet.com](http://www.MSAnet.com)



**MINE SAFETY APPLIANCES COMPANY  
CRANBERRY TWP., PENNSYLVANIA, U.S.A. 16066**

# SECOND STAGE REGULATOR

Item	P/N	Description
1	697453	O-ring, Silicone, Red
2	634669	O-ring, Fluro, Blue
3	10018540	Diaphragm, Silicone
4	10018547	U-clip
5	10018622	Retainer, Spring, Purge Cover ONLY
6	10018774	Knob, Bypass
7	10018965	Spring, Button
8	10018966	Body, Bypass
9	10018971	Insert, Bypass
10	10033174	Hose, 30" with Snap-Tite
	10033175	Hose, 42" with Snap-Tite
11	10020784	Screen, Bypass
12	10020931	Spring, Diaphragm
13	10023509	O-ring, Viton, Black
14	10037951	O-ring, Buna-N, Black
15	10024111	Button, PTC
	10024112	Button, STC
	10024111	Button, PTC
16	10087295	Valve Assembly
17	10087302	Housing, Regulator
18	10026139	Cover, Purge
	10047406	Cover, Non-Purge
19	10031192	Seal Ring
20	604070	Christo-Lube Lubricant

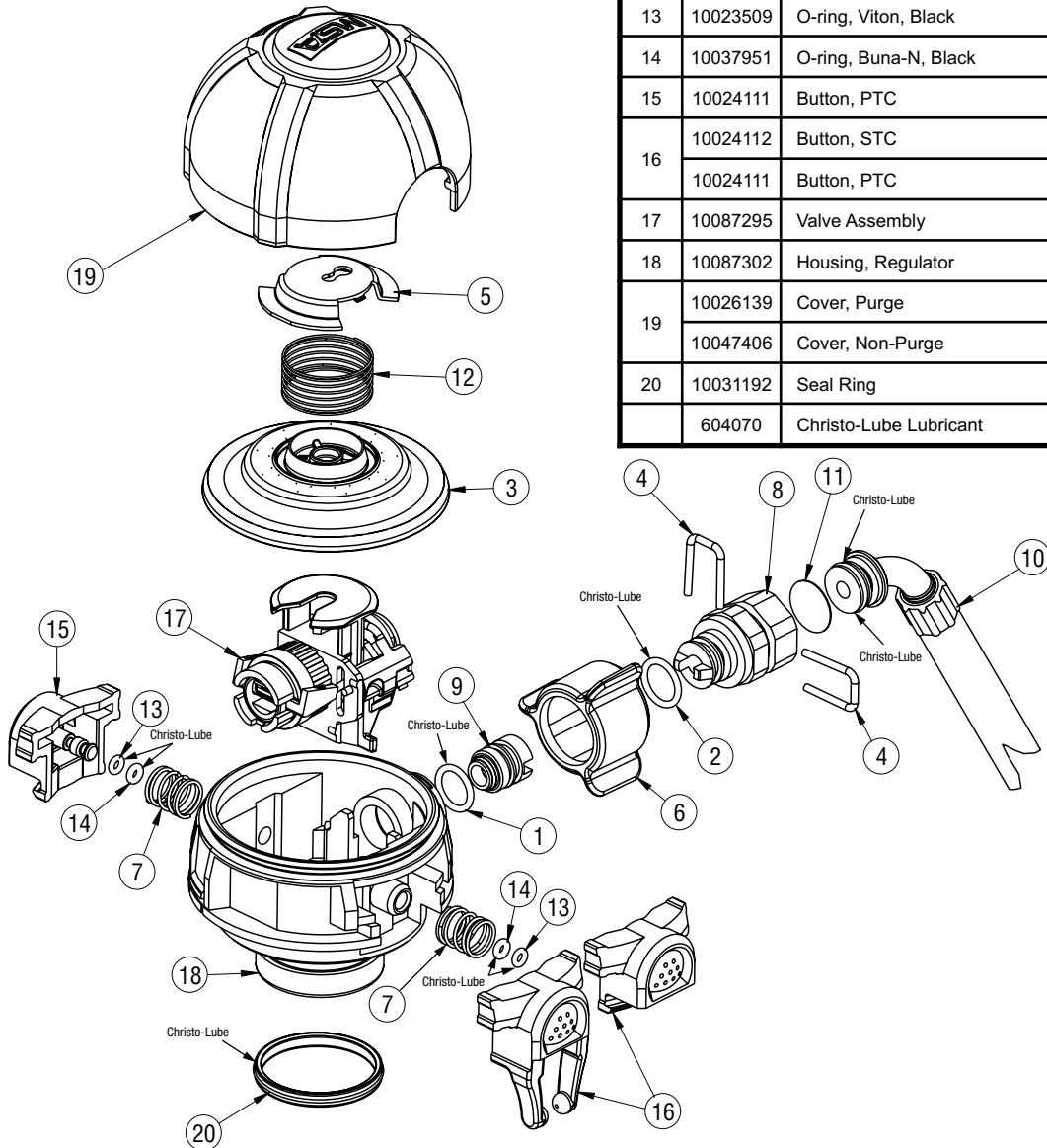

# SECOND STAGE REGULATOR

## Table of Contents

### Disassembly

Regulator Cover and Spring	4
Diaphragm	4
Bypass and Hose with Swivel	5
Valve Assembly	6
Regulator Housing Buttons	6
<b>Inspection of the Valve Fork for Proper Height</b>	
Acceptable Valve Fork Heights	7
Adjusting Valve Fork Height for Proper Performance	7
Adjustment of Valve Fork if Above the Maximum	8
Adjustment for Valve Fork if Below the Minimum	8

### Reassembly

Seal Ring	8
Regulator Housing and Buttons	9
Valve Assembly	9
Bypass and Hose Assembly	10
Diaphragm	11
Regulator Cover and Spring	11

## SECOND STAGE REGULATOR DISASSEMBLY

### Removing the Regulator Cover and Spring

1. Remove the regulator cover.

- a. Press and hold the release buttons while pressing the regulator housing retaining latches.



**Note:** Do not touch the cover while pressing the release buttons and retaining latches. Let the spring act on the cover.

- b. Allow the cover to drop into your palm.



- c. Remove the spring, and spring retainer from the regulator housing.



- d. Turn the spring clockwise to remove it from the retainer.

**Note:** Do not stretch the spring.

### Removing the Diaphragm

1. Roll the edge off the regulator housing.



2. Slide the diaphragm away from the bypass handwheel off the valve fork.



## SECOND STAGE REGULATOR

### Disassembling the Bypass and Hose with Swivel

1. Remove the regulator cover, spring, and spring retainer.

**Note:** It is not necessary to remove the diaphragm.

2. Use a small, flat-blade screwdriver to remove the U-clip.



3. Remove the bypass knob.



4. Remove the bypass body U-clip.



5. Remove the bypass and hose assembly by pulling the hose out of the bypass body.



6. Remove the hose assembly o-ring. Be careful not to scratch the o-ring groove.



7. Inspect the second groove of the hose swivel. Remove all dirt and foreign matter before reassembling the bypass body.

8. Use the plastic stick or small flat blade screwdriver to push the screen out of the bypass body. Inspect the bypass screen. Remove all dirt and foreign matter before reinstalling the screen.

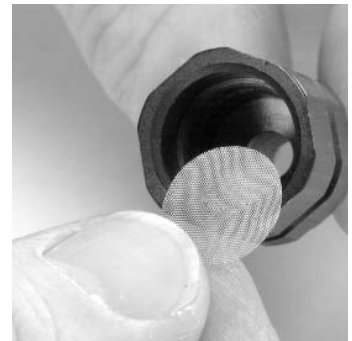

### Removing the Valve Assembly

1. Remove the regulator cover, spring, and spring retainer. (See **Removing the Regulator Cover, Spring, and Spring Retainer**)
2. Remove the diaphragm. (See **Removing the Diaphragm**)
3. Remove the U-clip from the regulator housing. (See **Disassembling the Bypass and Hose with Swivel**)
4. Remove the bypass insert.

**Note:** Use the bypass body as a tool to unscrew the bypass insert.



# SECOND STAGE REGULATOR

- a. Use the o-ring removal tool to remove the bypass insert.



- 5. Lift the valve out of the regulator housing.



## Disassembling the Regulator Housing Buttons

- 1. Remove the old o-rings. Be careful not to scratch the o-ring groove.

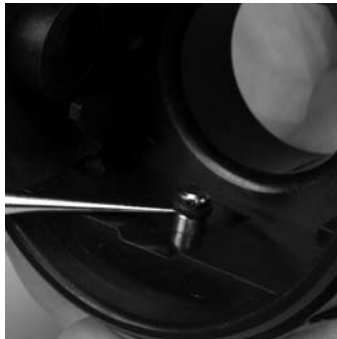

- a. Discard the ring.

- 2. The spring will push the button from the housing.



- a. Be careful not to lose the spring.
- b. Remove the old o-ring. Be careful not to scratch the o-ring groove.
- c. Discard the o-ring

## Removing the Seal Ring

- 1. Use the o-ring removal tool to remove the seal ring.
  - a. Discard the seal ring.



## Inspection of the Valve Fork for Proper Height Height Gauge 10090457

Inspect and adjust valve fork height with the valve fork pointing toward you. The valve fork assembly must move up and down freely.

- 1. Press the top of the valve fork to check movement.

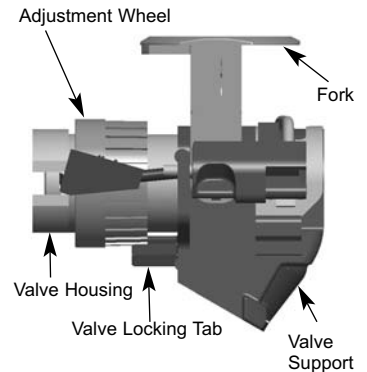

- 2. Use the height gauge to verify the fork height setting.
- 3. Center the gauge in the valve fork.

**Note:** Ensure that the valve assembly is vertical and can move freely.

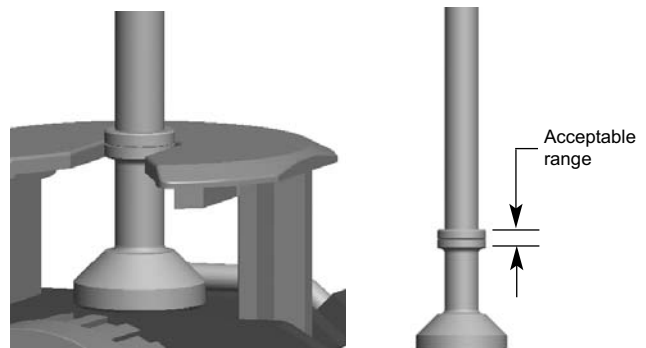

- 4. The top of the valve fork must be within the acceptable range.

# SECOND STAGE REGULATOR

## Acceptable Valve Fork Heights

Nominal height – Top of fork level with center of acceptable range.

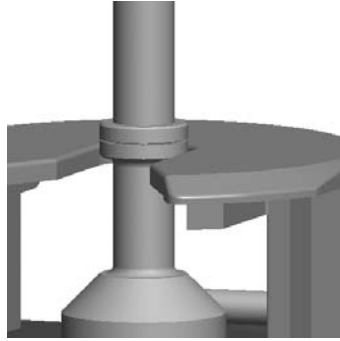

Maximum Height – Top of fork level with top of acceptable range.

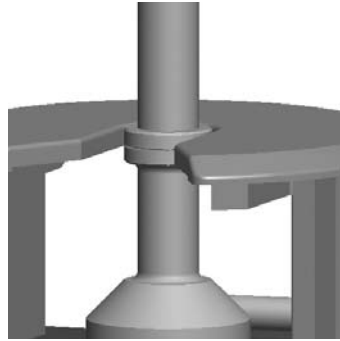

Minimum Height – Top of fork level with bottom of acceptable range.

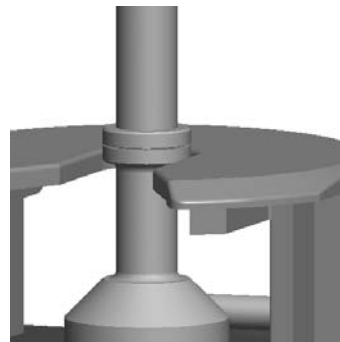

**Note:** If the top of the valve fork is above or below the acceptable range, adjust the valve. Normally the valve fork will not require adjustment. Do not adjust the valve if the fork is within the acceptable range.

### Adjusting Valve Fork Height for Proper Performance

**Adjustment of Valve Fork if Above the Maximum**  
Inspect and adjust valve fork height with the valve fork pointing toward you. Turn the Adjustment Wheel **clockwise to lower the fork**. Turn the adjustment wheel **counterclockwise to raise the fork**.

Above maximum height – Top of fork above top of acceptable range.

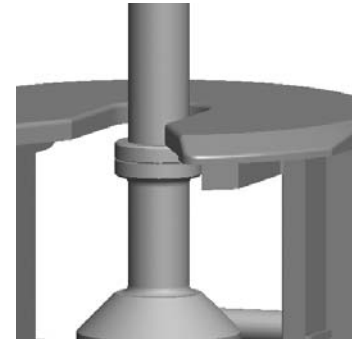

1. Slide the adjustment wheel and valve housing slightly away from the valve support to allow the adjustment wheel to rotate.

**Note:** The adjustment wheel cannot turn unless the ribs are free from the locking tab.

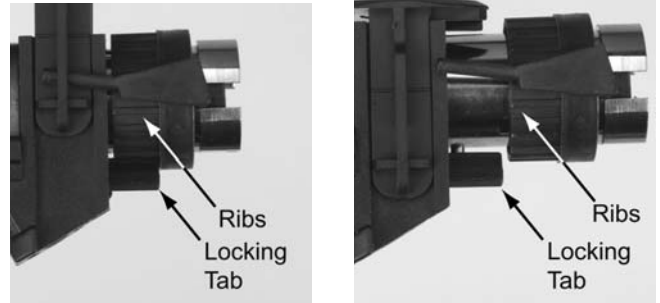

2. Turn the adjustment wheel clockwise to lower the fork.
3. Slide the adjustment wheel and valve housing back into place. Ensure that the valve lever and fork do not bind. The fork should move up and down easily.

### Adjustment for Valve Fork if Below the Minimum

Below minimum height – Top of fork is below acceptable range.

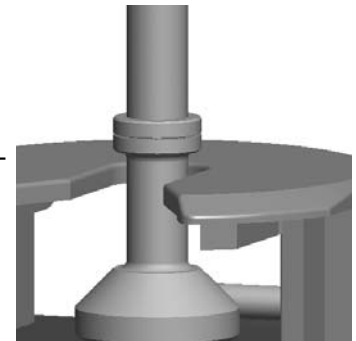

1. Slide the adjustment wheel and valve housing slightly away from the valve support to allow the adjustment wheel to rotate.
2. Turn the adjustment wheel counterclockwise to raise the fork.

**Note:** The adjustment wheel cannot turn unless the ribs are free from the locking tab.

# SECOND STAGE REGULATOR

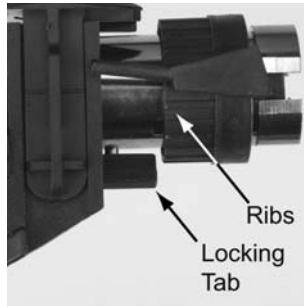
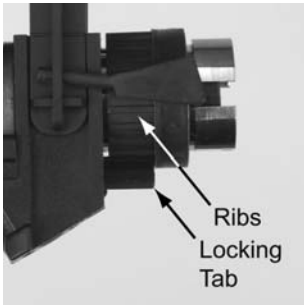

- Slide the valve housing back into place. Ensure that the valve lever and fork do not bind. The fork should move up and down easily.

## Second Stage Regulator Reassembly

### Installing the Regulator Seal Ring

Seal Ring **10031192**

- Apply a thin film of Christo-Lube lubricant to the new o-ring.

- Roll the new o-ring onto the regulator outlet and seat it into the o-ring groove.

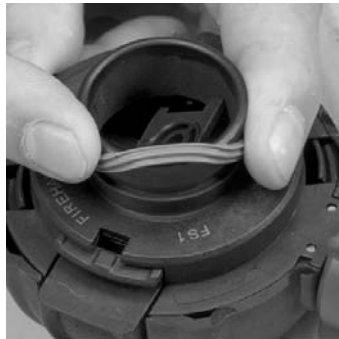

**Note:** An unseated seal can cause an air leak.

### Installing the Regulator Housing and Buttons

Housing Assembly **10087301**  
 O-Ring (2 Required) **10023509**  
 O-Ring (2 Required) **10037951**  
 Spring, Button **10018965**  
 Button, Push-to-Connect **10047238**

- Apply a thin film of Christo-Lube lubricant to the new o-rings.
- Install new o-rings on the button posts.



- Install the springs.
- Align the buttons.

**Note:** With the bypass at 9:00 o'clock, the slide button is at 12:00 o'clock and the housing button is at 6:00 o'clock.

- Push firmly on the buttons.
- Double check proper engagement by pulling on the buttons.
- Reinstall the diaphragm.
- Reinstall the spring and regulator cover.
- Check Valve Fork Height. (See **Adjusting Valve Fork Height for Proper Performance**)
- Flow Test the combination supplied-air respirator. (See **Introduction: PremAire Cadet Escape Respirator, P/N 10105221 for Flow Test and Overhaul Requirements**)

### Installing the Valve Assembly

Valve Assembly **10087295**  
 Housing Assembly **10087301**  
 Bypass Insert **10018971**  
 Christo-Lube Lubricant **604070**

- Insert the valve into the regulator housing with the valve fork up and facing away from the bypass port.



- Push the valve into the regulator housing.
- Reinstall the bypass insert.
  - Install a new o-ring.

- Protect the o-ring with tape or a thin piece of paper.



- Apply a small amount of Christo-Lube lubricant (P/N 604070) to the o-ring.

## SECOND STAGE REGULATOR

- iii. Slip the o-ring over the thread.



- iv. Remove the protective tape or paper.

- b. Install the bypass insert into the bypass port with the slot facing out.



4. Use the bypass body to screw the bypass insert into the valve. Hand tighten.

**Note:** If the bypass insert does not screw into the valve assembly easily, the valve assembly may not be properly aligned. Ensure that the valve assembly is seated fully in the regulator housing.

### Installing the Bypass and Hose Assembly

Bypass Screen

10020784

1. Install the bypass screen.



**Note:** Be careful not to damage the screen. Make sure that the screen lays flat inside the body.

2. Apply a thin film of Christo-Lube lubricant to a new o-ring.

3. Install the new o-ring into the first groove of the hose swivel.



4. Apply a thin film of Christo-Lube lubricant (P/N 604070) into the second groove of the hose swivel.

5. Insert the swivel into the bypass body.



6. Slide the U-clip through the bypass body.



**Note:** The U-clip should slide through the bypass body freely.

7. Slide the bypass knob onto the bypass body.





## SECOND STAGE REGULATOR

8. Insert the bypass body and hose assembly into the regulator housing so that the bypass body tabs line up with the slots in the bypass insert.



9. Ensure that the hose with swivel moves freely.



10. Slide the U-clip through the regulator housing.

**Note:** The U-clip should slide through the regulator housing freely.

### Installing the Diaphragm

1. Apply a thin coat of Christo-Lube to the top rim of the regulator housing and the bottom rim of the diaphragm.



2. Slide the diaphragm knob into the valve fork slot.

3. Slide the diaphragm toward the bypass handwheel.

4. Roll the diaphragm over the regulator-housing rim.



### Installing the Regulator Cover and Spring

Spring	<b>10092041</b>
Regulator Cover, Purge	<b>10047441</b>
Regulator Cover, Non-Purge	<b>10047664</b>

**Note:** The solid regulator cover does not use a spring retainer.

1. Insert the spring into solid cover.



- a. Slide the spring onto a finger.
- b. Insert spring and finger into the solid cover.
- c. Attach last coil of spring to cover hooks.

2. Hold the spring in the center of the cover.

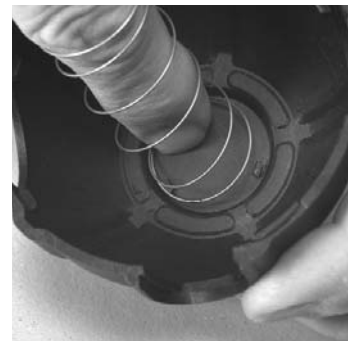

3. Engage the last coil of the spring to each of the three (3) molded hooks.

## SECOND STAGE REGULATOR

4. Ensure that the last coil of the spring is engaged to each of the three (3) molded hooks.

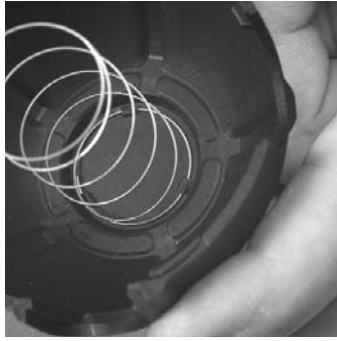

5. Attach spring and spring retainer (purge models only) by attaching last coil to retainer hooks.
6. Install the spring retainer.

- a. Pull the stem through the retainer.



7. Double check proper engagement by lifting spring retainer.
8. Push regulator cover, spring, and spring retainer onto regulator housing.
9. Visually inspect the tabs. Make sure both are properly engaged.

### **WARNING**

**Double check proper engagement of both retaining latches by visual inspection to ensure that the regulator cover is securely attached to the regulator housing. Failure to follow this warning could cause the regulator to malfunction resulting in serious personal injury or death.**