

FireHawk[®] M7 Carrier and Harness Assembly

MAINTENANCE AND REPAIR

For More Information, call 1-800-MSA-2222 or Visit Our Website at www.MSAnet.com



MINE SAFETY APPLIANCES COMPANY
PITTSBURGH, PENNSYLVANIA, U.S.A. 15230

REPLACEMENT KITS AND PARTS LIST

Replacement Kits

FireHawk M7 Carrier w/Labels (2216 psi/3000 psi)		
10090852	10083436	Carrier Assembly
	10084688	ID Label
	805430	Cylinder Band Label
		NIOSH Label
		CBRN Label
		NFPA Label
	10087293	FireHawk M7 Logo Label
FireHawk M7 Carrier w/Labels (4500 psi)		
10090853	10083436	Carrier Assembly
	10084688	ID Label
	805265	Cylinder Band Label
		NIOSH Label
		CBRN Label
		NFPA Label
	10087293	FireHawk M7 Logo Label
Chest Strap Replacement Kit		
10012167	10102886	Left Chest Strap
	10102861	Right Chest Strap
Strap and Belts		
10048173	10048173	Left Shoulder Strap
10102889	10102889	Right Shoulder Strap
10012167	10012167	Chest Strap
10102860	10102860	Left Double Pull Strap
10102859	10102859	Right Double Pull Strap
10083134	10083134	Swiveling Lumbar Pad
10102858	10102858	Left Double Pull Belt
10102838	10102838	Right Pull Belt
10022245	10022245	Belt Mount

Parts List

Item	P/N	Description
1	10086665	M7 Carrier & Harness w/ Chest Strap, 4500 psi
	10083129	M7 Carrier & Harness w/o Chest Strap, 4500 psi
	10086664	M7 Carrier & Harness w/ Chest Strap, 2216/3000 psi
	10083128	M7 Carrier & Harness w/o Chest Strap, 2216/3000 psi
	10086662	M7 Carrier & Harness w/ Chest Strap, Swiveling Lumbar, 4500 psi
	10086663	M7 Carrier & Harness w/ Chest Strap, Swiveling Lumbar, 2216/3000 psi
1a	10083436	M7 Backplate and Cylinder Band
2	10048173	Left Shoulder Strap
3	10102888	Right Shoulder Strap
4	10102886	Left Chest Strap
4a	10102861	Right Chest Strap
5	10102860	Left Double Pull Strap
6	10102859	Right Double Pull Strap
7	10016029	Tether
8	10022245	Belt Mount
9	10025941	Left Double Pull Belt
10	10102838	Right Double Pull Belt
11	10083134	Swiveling Lumbar Pad
12		M7 NIOSH Label
13		CBRN Label
14		M7 NFPA Label

FIREHAWK M7 CARRIER AND HARNESS ASSEMBLY

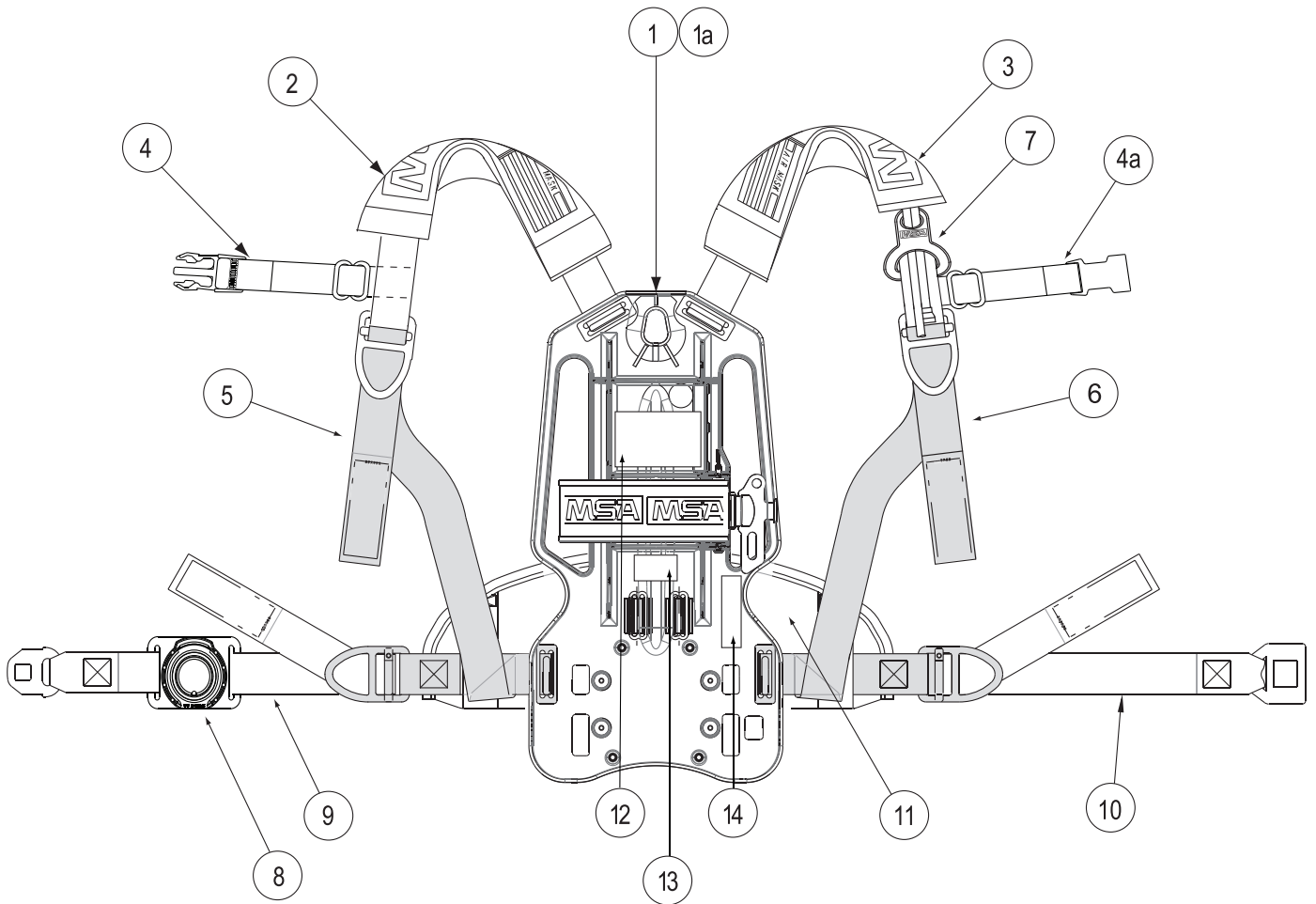

FIREHAWK M7 CARRIER AND HARNESS ASSEMBLY

Replacement Kits and Parts List (cont)

Item	P/N	Description	
Cylinder Friction Pad Kit			
15	10086667	10084777	Binding Post (3 Req'd)
		10109434	Aluminum Screws (3 Req'd)
		10083222	Friction Pad
Cylinder Band Label			
16	805430	Cylinder Band Label 2216/3000 psi	
	805265	Cylinder Band Label 4500 psi	
Shock Mount Kit			
17	10090283	10083223	Shock Mounts (4 req.)

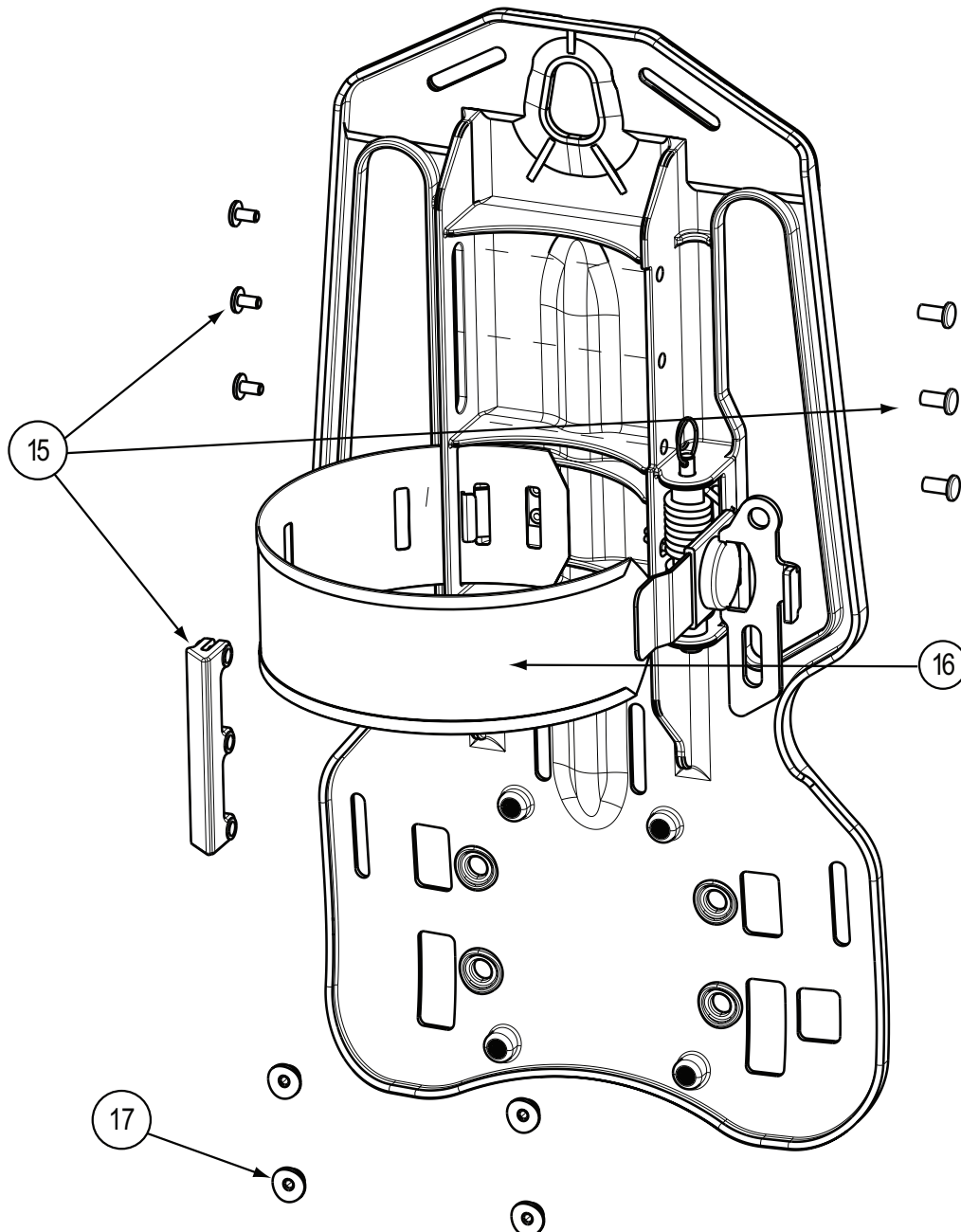

FIREHAWK M7 CARRIER AND HARNESS ASSEMBLY

Replacement Kits and Parts List (cont)

Item	P/N	Description
18	10086666	10083225 Cylinder Stop
		10084812 Screw (4 req.)
		10084815 Lock washer (4 req.)
19	10066867	Cylinder Band Adjuster
20	10058780	Rivet (2 req.)

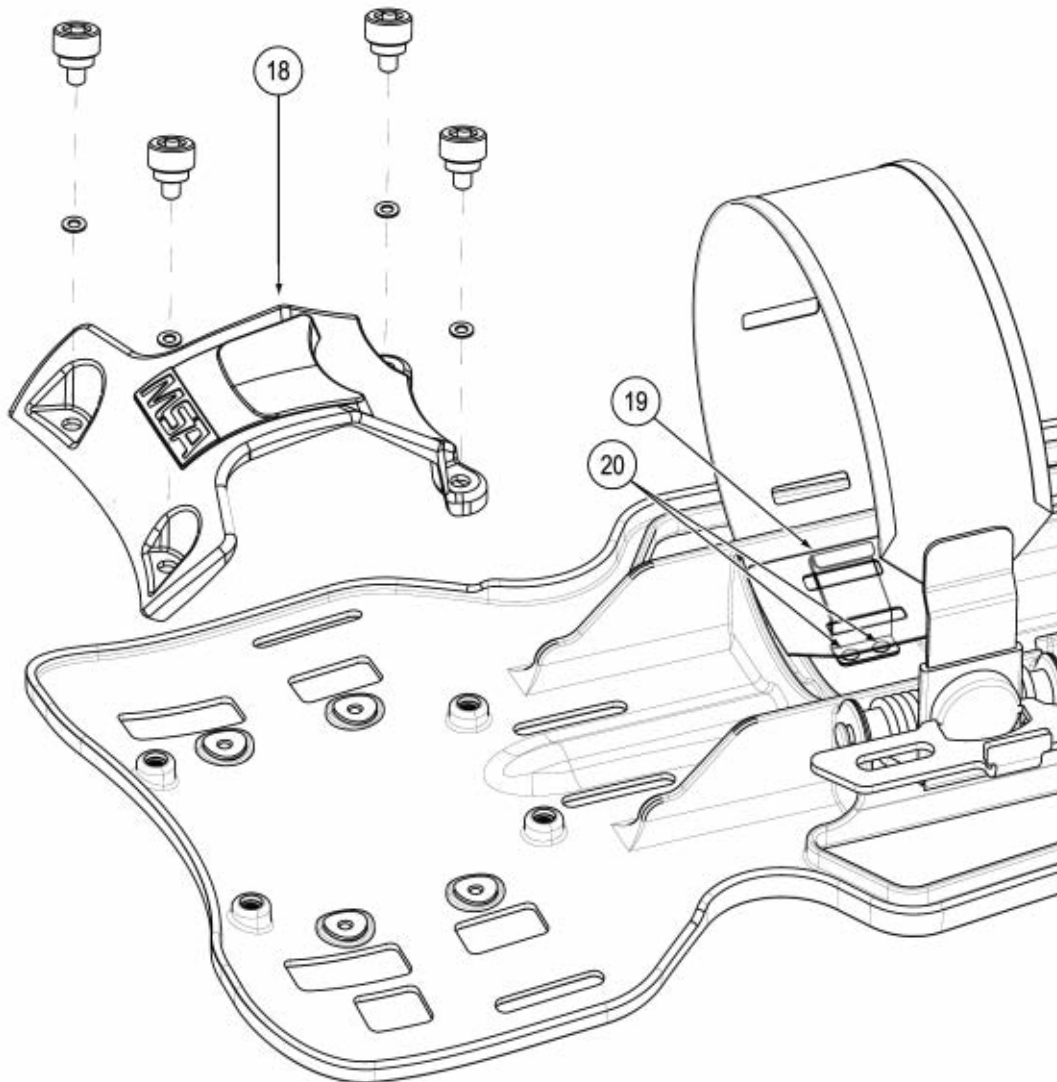

FIREHAWK M7 CARRIER AND HARNESS ASSEMBLY

Table of Contents

Disassembly

Friction Pad	6
Right Shoulder Strap	6
Left Shoulder Strap	6
Chest Strap	7
Waist Belts	7
Swiveling Lumbar Pad	7

Reassembly

Swiveling Lumbar Pad	7
Waist Belts	7
Chest Strap	8
Left Shoulder Strap	9
Right Shoulder Strap w/Tether	9
Friction Pad	10

DISASSEMBLY

Removing the Friction Pad

1. Remove the cylinder.
2. Use a slot head screwdriver to unscrew the Friction Pad screws.

Note: To ease access to the screws, remove the PR14 Mounting Bracket and pass the screwdriver through the slot.



Removing the Right Shoulder Strap

1. Remove the M7 Control Module. See **M7 Control Module Repair and Maintenance (P/N 10093089)** for Instructions.
2. Unlace the free end of the pull-strap from the friction buckle.



3. Remove the shoulder strap by angling the Tri-bar slide through the slot.

Removing the Left Shoulder Strap

1. Disconnect the second stage regulator from the intermediate pressure hose.



- a. If present, use an **11/16" wrench** to remove the ExtendAire manifold.



- b. Remove the o-ring and discard.



FIREHAWK M7 CARRIER AND HARNESS ASSEMBLY

2. Pull the first stage intermediate pressure hose through the shoulder strap.



3. Remove the pull-strap from the friction buckle.

Removing the Chest Strap

1. Unlace the ends of the chest strap from the slide buckles.



2. Pull the ends through through the tunnels in the chest straps.



Removing Waist Belts

Remove the waist pull-straps from the backplate by angling the tri-bar through the slots.



Removing the Swiveling Lumbar Pad

1. Remove the Swiveling Lumbar Pad by angling the tri-bars through the backplate slots.



REASSEMBLY

Installing the Swiveling Lumbar Pad

P/N 10083134

1. Position the Swiveling Lumbar Pad behind the backplate with the curved edge up.

2. Angle the tri-bars through the slots.



Installing Waist Belts

Left Double Pull Waist Belt: P/N 10025941

Right Double Pull Waist Belt: P/N 818374

1. Angle the tri-bar strap through the slot.
2. Tug on the belt to test the attachment.

3. From back to front, lace the free end of the pull-strap through the friction buckle.



FIREHAWK M7 CARRIER AND HARNESS ASSEMBLY

4. Pass the strap over the bar and back through the buckle.



5. Lace the strap through the slide buckle.



Installing the Chest Strap

Chest Strap Kit: P/N 10012167

Connect male and female ends of chest strap.

1. Extend the chest straps.



2. Lay the unconnected male end under the right shoulder strap.



3. Lay the unconnected end of the male chest strap under the left shoulder strap.



4. Pass the end through the tunnel in the strap.

- a. Lace the chest strap over the bar and down through the slide buckle.



- b. Pull the chest strap through.



6. Don the Carrier/Harness Assembly to check chest strap installation.

FIREHAWK M7 CARRIER AND HARNESS ASSEMBLY

Installing the Left Shoulder Strap

P/N 10048173

1. Install the shoulder strap by angling the tri-bar through the slot.
2. Tug on the shoulder strap to test the attachment.



4. Lace the free end of the pull-strap through the friction buckle.



- a. Twist the strap clockwise one half turn.



- b. With the fold down, pass the strap from back to front through the buckle.



- c. Pass the strap over the bar and back through the buckle.

- d. Pass the first stage intermediate-pressure hose through the tunnel.



5. Reinstall the intermediate pressure hose to the M7 ExtendAire manifold.



- a. Install a new o-ring.
- b. Use a torque wrench with **11/16" crowfoot** to tighten the connector to **75 ± 5 in lbs.**
- c. Ensure that the dust cover is properly attached.

6. Reconnect the intermediate-pressure hose.



- a. Use a torque wrench with **11/16" crowfoot** to tighten the connector to **125 ± 5 in lbs.**

FIREHAWK M7 CARRIER AND HARNESS ASSEMBLY

Installing the Right Shoulder Strap

Right Shoulder Strap P/N 818381
Tether P/N 10016029

1. Install the shoulder strap by angling the tri-bar through the slot.



2. Tug on the shoulder strap to test the attachment.



3. Install the tether.

- a. Pass the friction buckle through the tether's large opening.



Note: If using the optional chest strap install the tether above the chest strap.



4. Lace the free end of the pull-strap through the friction buckle.

- a. Fully extend the shoulder and pull strap. Make sure the straps are untwisted.



- b. Twist the pull strap counterclockwise one-half turn.



- c. With the fold down, pass the strap from back to front through the buckle.



- d. Pass the strap over the bar and back through the buckle.



- e. Reinstall the M7 Control Module. (See **M7 Control Module Maintenance and Repair** for instructions.)

FIREHAWK M7 CARRIER AND HARNESS ASSEMBLY

Installing the Friction Pad

Cylinder Friction Pad Kit P/N 10086667

1. Remove the cylinder.
2. Position the new Friction Pad on the backplate.

Note: Ensure that the Friction Pad face slopes toward the center of the backplate.



3. Insert T-nuts through the holes.



4. Insert screws.



5. Use a slot head screwdriver to tighten the Friction Pad screws.

Note: To ease access to the screws, remove the PR-14 Mounting Bracket and pass the screwdriver through the slot.

