

MODEL NUMBER

USER INSTRUCTIONS

BOLT D-RING ANCHORAGE CONNECTOR

WARNING

National standards and state, provincial and federal laws require the user to be trained before using this product. Use this manual as part of a user safety training program that is appropriate for the user's occupation. These instructions must be provided to users before use of the product and retained for ready reference by the user. The user must read, and understand (or have explained), and heed all instructions, labels, markings and warnings supplied with this product and with those products intended for use in association with it. FAILURE TO DO SO MAY RESULT IN SERIOUS INJURY OR DEATH.

1.0 SPECIFICATIONS

- MSA Bolt D-Ring Anchorage Connectors meet OSHA requirements, ANSI A10.14 Type 1, and ANSI Z359.1 standards.
- The Bolt D-Ring has a minimum breaking strength of 5,000 lbf (22.2 kN).
- The Bolt D-Ring is constructed of forged alloy steel, is zinc plated and 100% proof tested to 3,600 lbf (16 kN).
- The Bolt D-Ring is designed for the attachment of a single personal fall arrest system.
- When used as part of a personal fall arrest system, fall arresting forces must not exceed 1,800 lbf (8 kN).
- Capacity is 310 lbs (140 kg) including weight of the user plus clothing, tools and other user-borne objects.

2.0 DESCRIPTION

The Bolt D-Ring is a component designed specifically for coupling a single personal fall arrest system to an anchorage. The Bolt D-Ring is a permanent anchorage connector intended for use on such anchorages as beams or girders.

For More Information, call 1-800-MSA-2222
or Visit Our Website at www.MSAnet.com

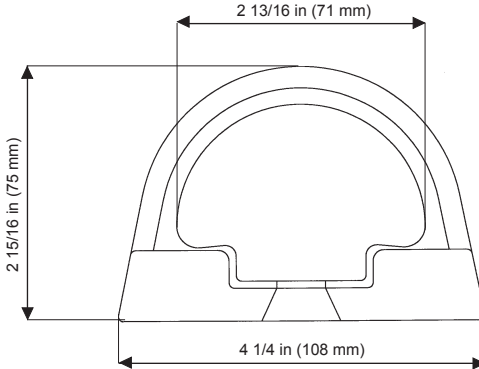

MINE SAFETY APPLIANCES COMPANY
PITTSBURGH, PENNSYLVANIA, U.S.A. 15230

2.1 MODEL 10003213 – BOLT D-RING WITH THRU HOLE 5/8" BOLT**MODEL 10057965 – BOLT D-RING WITH THRU HOLE 3/4" BOLT****3.0 SELECTION & APPLICATION****3.1 PURPOSE OF BOLT D-RING**

The Bolt D-Ring is primarily a component of a personal fall arrest system, serving as an anchorage connector. It may also be used for work positioning, travel restriction, rescue, retrieval, evacuation and confined space entry/exit operations, depending on the associated system components used together with the Bolt D-Ring.

Use of the Bolt D-Ring must comply with these User Instructions, and further, is subject to approval under the user's safety rules and regulations and by the user's safety director, supervisor or qualified safety engineer. Be certain the selection of the Bolt D-Ring Anchorage Connector is suited for the intended use and work environment. If there is any conflict between these User Instructions and other directives or procedures of the user's organization, do not use the Bolt D-Ring until such conflicts are resolved. Consult all local, state and federal Occupational Health and Safety Administration (OSHA) requirements for personal safety equipment. Also refer to the latest revision of ANSI Z359.1 and ANSI A10.14 standards for more information on anchorage connectors and associated system components. In Canada, refer to provincial and federal regulations.

3.2 LIMITATIONS

The following applications limitations must be considered and planned for before using the MSA Bolt D-Ring Anchorage Connector.

3.2.1 PHYSICAL LIMITATIONS

The Bolt D-Ring is designed for one person with a combined total weight no greater than 310 lbs (140 kg), including clothing, tools and other user-borne objects.

3.2.2 CHEMICAL HAZARDS

Acidic, alkaline or other environments with harsh substances may damage the hardware elements of the Bolt D-Ring. If working in a chemically aggressive environment, consult MSA to determine which anchorage connector material is better for your specific conditions. When working in the presence of chemicals, more frequent inspection of the Bolt D-Ring is required.

3.2.3 CORROSION

Do not expose the Bolt D-Ring to corrosive environments for prolonged periods. Organic substances and salt water are particularly corrosive to metal parts. When working in corrosive environments, more frequent inspection, cleaning and drying of the Bolt D-Ring is required.

3.2.4 ELECTRICAL HAZARDS

Use extreme caution when working near energized electrical sources. Metal hardware will conduct electric current. Maintain a safe working distance (preferably at least 10 feet – 3 m) from electrical hazards.

3.2.5 IMPACT FORCES

Any Bolt D-Ring Anchorage Connector which has been subjected to the forces of arresting a fall must be immediately removed from service and marked as "UNUSABLE" until destroyed.

3.3 COMPATIBILITY OF SYSTEM PARTS

3.3.1 COMPATIBILITY OF COMPONENTS AND SUBSYSTEMS

MSA Bolt D-Ring Anchorage Connectors are designed to be used with MSA approved components and connecting subsystems. Use of the Bolt D-Ring Anchorage Connector with products made by others that are not approved in writing by MSA may adversely affect the functional compatibility between system parts and the safety and reliability of the complete system. Connecting subsystems must be suitable for use in the application (e.g. fall arrest, climbing protection, restraint, rescue or evacuation). MSA produces a complete line of connecting subsystems for each application. Contact MSA for further information. Refer to the manufacturer's instructions supplied with the component or connecting subsystem to determine suitability. For fall arrest applications using MSA Bolt D-Ring Anchorage Connectors, the maximum fall arrest force must not exceed 1,800 lbf (8 kN). Contact MSA with any questions regarding compatibility of equipment used with the MSA Bolt D-Ring Anchorage Connectors.

3.3.2 COMPATIBILITY OF CONNECTORS

Connectors, such as D-rings, snaphooks, and carabiners, must be rated at 5,000 lbf (22 kN) minimum breaking strength. MSA connectors meet this requirement. Connecting hardware must be compatible in size, shape, and strength. Non-compatible connectors may accidentally disengage ("rollout"). Always verify that the connecting snaphook or carabiner and the D-ring on the harness or anchorage connector are compatible. Use only self-closing, self-locking snaphooks and carabiners (as defined and required by ANSI Z359.1).

3.3.3 ANCHORAGES AND ANCHORAGE CONNECTORS

Anchorage for personal fall arrest systems must have a strength capable of supporting a static load, applied in directions permitted by the system, of at least: (a) 3,600 lbf (16 kN) when certification exists, or (b) 5,000 lbf (22.2 kN) in the absence of certification. See ANSI Z359.1 for definition of certification. When more than one personal fall arrest system is attached to an anchorage, the anchorage strengths set forth in (a) and (b) must be multiplied by the number of systems attached to the anchorage. See ANSI Z359.1, section 7.2.3. This requirement is consistent with OSHA requirements under 20 CFR 1910, Subpart F, Section 1910.66,

Appendix C. In addition, it is recommended that the user of personal fall arrest systems refer to ANSI Z359.1, Section 7, for important considerations in equipment selection, rigging, use, and training.

 **CAUTION**

The anchorage to which the Bolt D-Ring is attached must be rated for loading in the direction of intended use.

4.0 INSTALLATION OF THE BOLT D-RING ANCHORAGE CONNECTOR

4.1 PREPARATION

Begin by preparing the anchorage (e.g. beam, girder, etc.). The anchorage should be clean and dry before installing the Bolt D-Ring Anchorage Connector. Holes must be drilled into the flange of the anchorage that match the diameter of the mounting hole and the size of the mounting bolt. See section 3 for considerations in locating the anchorage connectors for the work to be performed.

 **CAUTION**

When installing or removing the Bolt D-Ring Anchorage Connector, limit exposure to fall hazards. A separate independent fall arrest system may be required.

4.2 INSTALLATION

4.2.1 MODELS 10003213 AND 10057965 BOLT-D RING WITH THROUGH HOLE

Required for installation:

- Bolt, sized to match appropriate Bolt D-Ring, Grade 8 with sufficient length to reach through the anchorage and secure the lock washer and nut.
- Nut with threads to match the Grade 8 bolt.
- Lock washer, sized to match appropriate bolt.

- Step 1: Line up Bolt D-ring with mounting hole prepared in the anchorage.
- Step 2: Assemble the Grade 8 bolt through the hole in the Bolt D-Ring and anchorage hole. Assemble the washer and nut. Hand tighten. Nut must be fully engaged to threads of bolt.
- Step 3: Tighten nut to 145 - 155 ft lb (196 - 210 Nm) torque for a 5/8" bolt.
Tighten nut to 240 - 250 ft lb (325 - 338 Nm) torque for a 3/4" bolt.
- Step 4: Inspect the installation. Verify that all components are present and correctly mounted.

FIGURE 1

ALL MODELS BEING INSTALLED

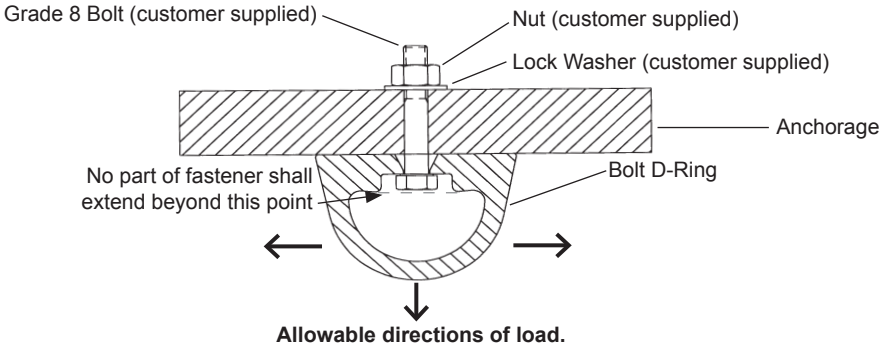

CAUTION

Do not leave the Bolt D-Ring Anchorage Connector installed in environments which could cause damage or deterioration to the product. Refer to sections 5 and 7 for care and inspection details. Do not leave unattended loads on the Bolt D-Ring Anchorage Connector.

4.3 MAKING CONNECTIONS

When using a snaphook or carabiner to connect to an anchorage or when coupling components of the system together, be certain accidental disengagement ("rollout") cannot occur. Rollout is possible when interference between a carabiner and the mating connector causes the carabiner's gate or keeper to accidentally open and release. Rollout occurs when a carabiner is snapped into an undersized ring such as an eye bolt or other non-compatibly shaped connector. Only self closing, self-locking snaphooks and carabiners should be used to reduce the possibility of rollout when making connections. Do not use snaphooks or connectors that will not completely close over the attachment object. Do not make knots in a lanyard. Do not hook a lanyard back onto itself. Snaphooks and carabiners must not be connected to each other. Do not attach two snaphooks or carabiners into one D-ring. Do not attach snaphooks or carabiners directly to a horizontal lifeline. Always follow the manufacturer's instructions supplied with each system component.

4.4 REMOVAL OF THE BOLT D-RING ANCHORAGE CONNECTOR

Before attempting removal of the Bolt D-Ring Anchorage Connector, disconnect all loads and attachment elements from the Anchorage Connector D-ring. Return the Bolt D-Ring Anchorage Connector to the appropriate person in the user's organization for cleaning, inspection and storage.

5.0 CARE, MAINTENANCE AND STORAGE

5.1 CLEANING INSTRUCTIONS

Clean the Bolt D-Ring Anchorage Connector with a solution of water and mild laundry detergent. Dry hardware with a clean cloth and hang to air dry. Do not speed dry with heat. Excessive accumulation of dirt, paint or other foreign matter may prevent proper function of the Bolt D-Ring Anchorage Connector. Questions concerning Bolt D-Ring Anchorage Connector conditions and cleaning should be directed to MSA.

5.2 MAINTENANCE AND SERVICE

Equipment which is damaged or in need of scheduled maintenance must be tagged as “UNUSABLE” and removed from service. Corrective maintenance (other than cleaning) and repair, such as replacement of elements, must be performed by MSA. Do not attempt repairs.

5.3 STORAGE

Store the Bolt D-Ring Anchorage Connector in a cool, dry and clean place out of direct sunlight. Avoid areas where heat, moisture, light, oil, and chemicals or their vapors or other degrading elements may be present. Equipment which is damaged or in need of scheduled maintenance should not be stored in the same area as usable equipment. Heavily soiled, wet, or otherwise contaminated equipment should be properly maintained (e.g. dried and cleaned) prior to storage. Prior to using equipment which has been stored for long periods of time, a Formal Inspection should be performed by a competent person.

6.0 MARKINGS & LABELS

The following labels must be present, legible and securely attached to the Bolt-D Anchorage Connector.

<p>WARNING • Follow manufacturer's instructions provided with this product • Failure to do so may result in serious injury or death • Inspect before each use</p>	<p>BOLT D-RING ANCHORAGE CONNECTOR Model #: SHWA3732A / 10003213 / SHWA3732C Material: Steel, Zinc Plated Capacity: 310 lbs (140 kg) person + clothes + tools Meets: OSHA, ANSI A10.14, ANSI Z359.1</p>	 <p>MSA Corporate Headquarters P.O. Box 426, Pittsburgh, PA 15230 USA 1-800-672-2222</p>
<p>P/N 10004966, Rev.D</p>	<p>DO NOT REMOVE LABEL</p>	<p>MADE IN CANADA</p>

(label shown here not actual size)

7.0 INSPECTION

7.1 INSPECTION FREQUENCY

The Bolt D-Ring Anchorage Connector must be inspected by the user before each use and, additionally, by a competent person other than the user at intervals of no more than six months. The competent person inspection is referred to as Formal Inspection.



If the Bolt D-Ring Anchorage Connector has been subjected to fall arrest or impact forces, it must be immediately removed from service and marked as "UNUSABLE" until destroyed.

7.2 INSPECTION STEPS

- Step 1: Inspect the Bolt D-Ring Anchorage Connector labels to verify that they are present and legible. See section 6 for the specific labels that should be present and the information contained on those for the model number shown on page one (1) of these instructions. Check the Formal Inspection Grid to be sure a Formal Inspection has been performed within the last six months. If the Grid does not indicate that a Formal Inspection has been performed within the last six months (by being punched), or if any labels are missing or illegible, remove the Bolt D-Ring Anchorage Connector from use and mark it as "UNUSABLE" until a Formal Inspection is performed by a competent person.
- Step 2: Inspect the Bolt D-ring, and fasteners (bolt, washer and nut) for deformations, fractures, cracks, corrosion, deep pitting, sharp edges, cuts, deep nicks and evidence of excessive heat or chemical exposures.

- Step 3: Inspect the plastic label for its presence and legibility.
- Step 4: Inspect each component and subsystem of the complete system in accordance with the associated manufacturer's instructions.

7.3 CORRECTIVE ACTION

When inspection in accordance with section 7 reveals signs of inadequate maintenance, the Bolt D-Ring Anchorage Connector must be immediately removed from service and marked as "UNUSABLE" until destroyed or subjected to corrective maintenance by the user's organization in accordance with section 9. Damage, excessive wear, malfunction, and aging are generally not repairable. If detected, immediately remove the Bolt D-Ring Anchorage Connector from use and mark it as "UNUSABLE" until destroyed. For final disposition, submit the Bolt D-Ring Anchorage Connector to a competent person who is authorized to perform Formal Inspection. If there is any question as to repairability, contact MSA or a service center authorized in writing by MSA before further use of the product.



Only MSA or parties authorized in writing may make repairs to this equipment.

8.0 INSPECTION GRID

Punch month of first use.

	J	F	M	A	M	J	J	A	S	O	N	D
1st												
2nd												
3rd												
4th												
5th												
6th												

WARRANTY

Express Warranty – MSA warrants that the product furnished is free from mechanical defects or faulty workmanship for a period of one (1) year from first use or eighteen (18) months from date of shipment, whichever occurs first, provided it is maintained and used in accordance with MSA's instructions and/or recommendations. Replacement parts and repairs are warranted for ninety (90) days from the date of repair of the product or sale of the replacement part, whichever occurs first. MSA shall be released from all obligations under this warranty in the event repairs or modifications are made by persons other than its own authorized service personnel or if the warranty claim results from misuse of the product. No agent, employee or representative of MSA may bind MSA to any affirmation, representation or modification of the warranty concerning the goods sold under this contract. MSA makes no warranty concerning components or accessories not manufactured by MSA, but will pass on to the Purchaser all warranties of manufacturers of such components. THIS WARRANTY IS IN LIEU OF ALL OTHER WARRANTIES, EXPRESS, IMPLIED OR STATUTORY, AND IS STRICTLY LIMITED TO THE TERMS HEREOF. MSA SPECIFICALLY DISCLAIMS ANY WARRANTY OF MERCHANTABILITY OR FITNESS FOR A PARTICULAR PURPOSE.

Exclusive Remedy - It is expressly agreed that the Purchaser's sole and exclusive remedy for breach of the above warranty, for any tortious conduct of MSA, or for any other cause of action, shall be the repair and/or replacement, at MSA's option, of any equipment or parts thereof, that after examination by MSA are proven to be defective. Replacement equipment and/or parts will be provided at no cost to the Purchaser, F.O.B. Purchaser's named place of destination. Failure of MSA to successfully repair any nonconforming product shall not cause the remedy established hereby to fail of its essential purpose.

Exclusion of Consequential Damages - Purchaser specifically understands and agrees that under no circumstances will MSA be liable to Purchaser for economic, special, incidental, or consequential damages or losses of any kind whatsoever, including but not limited to, loss of anticipated profits and any other loss caused by reason of the non-operation of the goods. This exclusion is applicable to claims for breach of warranty, tortious conduct or any other cause of action against MSA.

For additional information, please contact the Customer Service Department at 1-800-MSA-2222 (1-800-672-2222).

**MSA CORPORATE HEADQUARTERS P.O. BOX 426
PITTSBURGH ■ PA ■ 15230 ■ USA
TEL. 1-800-672-2222 ■ FAX 1-800-967-0398
TECHNICAL SUPPORT LINE 1-888-421-8324
IN CANADA 1-800-267-0672
IN MEXICO 52 (2) 1 22 57 30**

Bolt D-Ring™ is a trademark of MSA.